

[72] Inventor **Rudolf Hepp**
 Schmidt-Ott-Strasse 7a, 1 Berlin 41,
 Germany
 [21] Appl. No. **783,593**
 [22] Filed **Dec. 13, 1968**
 [45] Patented **Mar. 30, 1971**
 [32] Priority **Apr. 19, 1968**
 [33] **Germany**
 [31] **P 17 61 209.8**

[56] **References Cited**
UNITED STATES PATENTS
 1,829,833 11/1931 Kast 270/55
 1,845,412 2/1932 Hathaway..... 270/55
 2,390,901 12/1945 Schramm 270/54
Primary Examiner—Robert W. Michell
Assistant Examiner—Paul V. Williams
Attorney—Karl F. Ross

[54] **DEVICES FOR SEPARATING FOLDED SHEETS OF PAPER AND THE LIKE**
 5 Claims, 12 Drawing Figs.

[52] U.S. Cl. 270/54
 [51] Int. Cl. B65h 5/30
 [50] Field of Search..... 270/54, 55

ABSTRACT: The present invention relates to a device for parting folded sheets of material, or assemblies of such sheets, in a manner such that where there are more than two leaves or pages in the assembly the internally disposed ones may also be parted in a determinate manner by the creation in them of a bending stress consequent upon the intermittent introduction between them of a separator element.

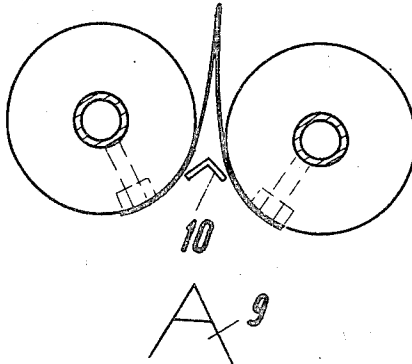

Fig. 1

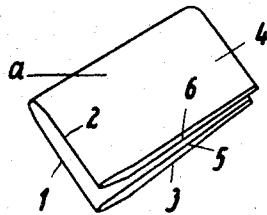

Fig. 2

Fig. 3

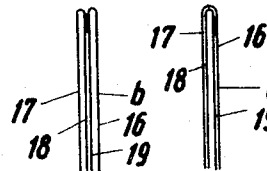

Fig. 4

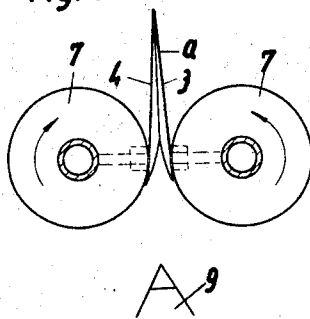

Fig. 5

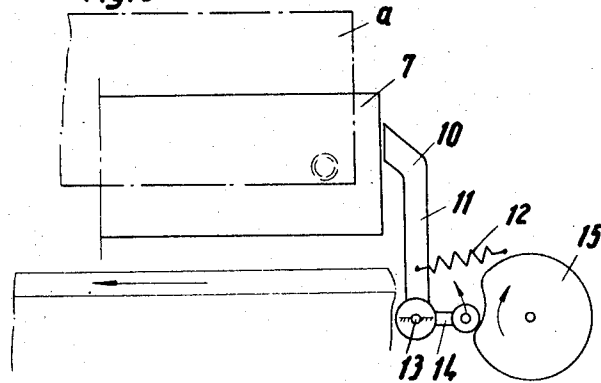

Fig. 6

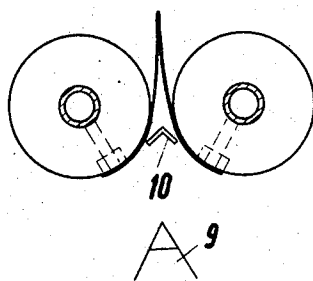
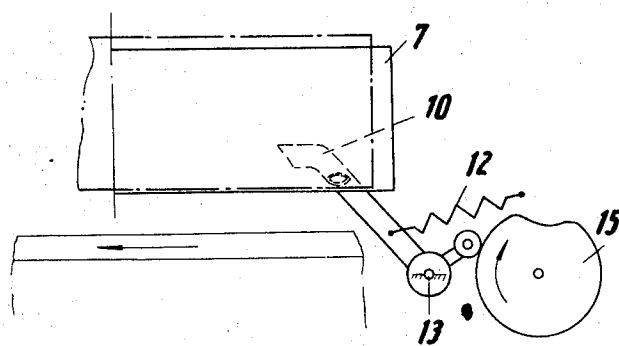

Fig. 7



Inventor:

Rudolf Hepp

By:

Karl F. Ross

Attorney

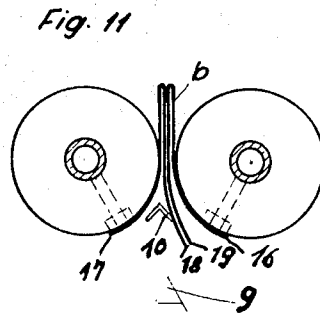
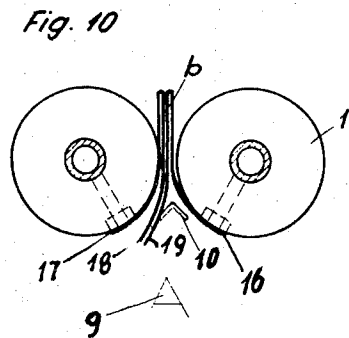
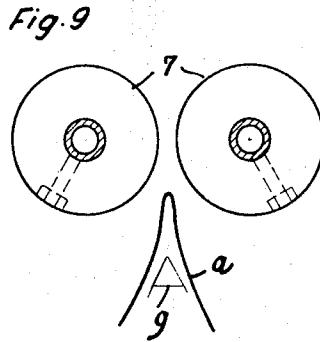
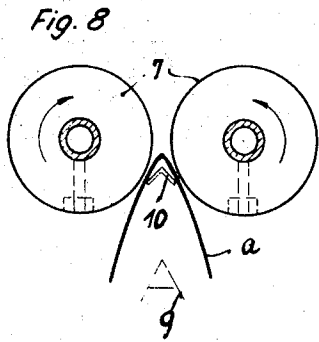
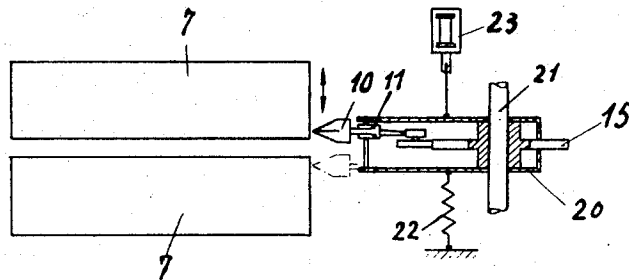

Fig. 12



Inventor:
Rudolf Hepp

By: **Karl F. Ross**
Attorney

DEVICES FOR SEPARATING FOLDED SHEETS OF PAPER AND THE LIKE

The present invention relates to a method of and a device for, parting individual sheets of paper or the like, or units made up of several sheets.

The function of parting folded sheets, is well known. The sheets are withdrawn individually from a stacking device and, their leading edges being spread apart, are placed upon a conveyor chain which feeds the parted sheets to a further processing stage. A known parting device of this kind consists of two cylinders rotating in mutually opposite directions, which are provided superficially with gripper elements for seizing the leading edges of the pages. Sheets can also be handled which are asymmetrically folded; in this context, one half of the sheet projects somewhat beyond the other half. The projecting edge thus produced, can be gripped by mechanical gripper elements, while the sheets where there is no such projecting part, pneumatic gripper elements are employed. The sheet or sheet unit taken from the stacking device, passes with its, or their folded edge in the trailing position, between the two cylinders. In passing through the cylinders, the leading edges of the two sheets are seized and with further rotation of the cylinders are spread apart, to be dropped, when the deployment has been completed, so that the spread sheet falls onto a conveyor chain located below.

These known parting devices are particularly well suited for the processing of four-sided sheets, and, in specific conditions, also cross-folded sheets. However, if multipaged cross-folded sheets or units are going to be parted, then this known kind of device fails because it can only seize and part the externally disposed pages whilst the inside ones are not affected. Sheet units of this kind may for example consist of several sheets, of all kinds, arranged inside one another or stuck together. Sheet units of this kind occur for example as sections of books or signatures in the bookbinding trade. When handling cross-folded sheets, central parting must be carried out whereas with sheet units made up of several sheets, parting between a page seized by one parting cylinder, and the other pages, is required in order to unite several sheet units, for example by stitching, in the manner customary in the bookbinding trade. Hitherto, it was necessary to carry out this parting by hand because the known parting devices were incapable of carrying out the aforesaid function; in other words, they could not part sheet units of the aforesaid kind because the internal pages, not seized by the parting cylinders, were not affected by the operation.

It is the object of the present invention to create a process and a device by means of which it is possible to part sheets or sheet units of this kind, consisting of a plurality of pages, for example sections of books, in each case at the desired position. In accordance with the invention, this object is achieved by virtue of the fact that parting is carried out by conventional parting elements which engage the externally disposed (outer) pages, and that during the parting of these pages, the internal (inner) pages, not engaged by the parting elements, are subjected to a bending stress which causes them to part as well. A further feature of the process resides in the fact that during the parting of the externally disposed pages, there is inserted between the pages not affected by the parting elements, a separator element which produces the bending stress, said separator element being withdrawn again before the sheet unit leaves the parting device.

The device for implementing the process of the invention is characterized in that in front of the cylinders, there is arranged a ridge-shaped separator element which, intermittently and as a function of the cylinder speed, can be swung parallel to the cylinder axes into the lower zone of the gap formed between them. A further feature resides in the fact that the separator element is arranged upon a rocking lever which is spring-loaded, said lever being controlled by a cam which produces an intermittent movement in it. The invention is characterized, furthermore, by the fact that the rocking lever and the cam are arranged in a housing longitudinally dis-

placeable upon the cam shaft and designed to be set to two terminal positions. It is an essential factor in this context that on one transverse side of the housing a tension spring is arranged and on the other transverse side is disposed the armature of a solenoid which is actuated by the control equipment of the machine.

In the method and device according to the invention, the parting of the internal pages, not engaged by the gripper elements, is achieved in that during the parting of the externally disposed pages, a separator element is intermittently inserted between the other pages at the particular point at which parting is desired, said element being operated as a function of the speed of rotation of the cylinders so that after the engagement of the leading edges of the externally disposed pages by the gripper elements, it is introduced at the desired position into the unparted pages and induces in these a bending stress which causes them to part. Before the sheet unit leaves the cylinders of the parting device, the separator element is withdrawn from the sheet unit so that the latter, with its internal pages spread in the desired way, is deposited upon the conveyor chain and is moved to the next processing stage in the properly parted condition. The separator element engages in the lower zone of the gap formed between the two cylinders, and in the case of cross-folded sheets produces central parting because it enters between the internally situated pages and forces them apart over their full length while where sheet units made up of several sheets are concerned, asymmetrical parting between one or other of the external pages seized by a parting cylinder, and the internal pages, is produced. In order to achieve such varying asymmetrical parting, the separator element is arranged to be transversely displaceable within the nip or gap of the cylinders, and in one terminal position it produces parting between one external page and the other pages, while in the other terminal position it produces parting between the other external page and the other pages. Where cross-folded sheets are concerned, in all instances central parting takes place since, due to the cross-folding, the parting element is inevitably in all cases introduced between the internal pages. If the cross-folded sheet comprises a priority of pages, then the separator elements in accordance with the invention must be employed to achieve proper parting of the internal, central pages.

The invention will now be described making reference to the accompanying drawing which illustrate the invention.

In the drawing:

FIG. 1 is an illustration, in perspective, of a cross-folded sheet;

FIG. 2 is a section through a sheet unit constituted by two superimposed folded sheets which have been stuck together;

FIG. 3 is a section through a sheet unit consisting of two sheets which have been placed one inside the other and stuck together at the crease or folded edge;

FIG. 4 is a schematic illustration of the known parting device, in the context of a sheet in accordance with FIG. 1;

FIG. 5 is a schematic illustration of the subject of FIG. 4, with the separator element in accordance with the invention, the view being a side elevation;

FIGS. 6 to 9 illustrate various operational positions of the parting element, the separator element and the sheet of FIG. 1;

FIG. 10 is an illustration of the subject of FIG. 6, when parting a sheet unit in accordance with FIGS. 2 and 3;

FIG. 11 is an illustration of the subject of FIG. 10 showing a different manner of parting sheet units in accordance with FIGS. 2 and 3; and

FIG. 12 is a schematic plan view of the separator element in accordance with the invention.

As FIGS. 1 to 3 illustrate, the parting device in accordance with the invention is being applied to a cross-folded multipage sheet in accordance with FIG. 1 which has folded leading edges 1, 2 and has externally disposed pages 3, 4 plus the central, internally disposed pages 5, 6. FIG. 2 illustrates a sheet unit consisting of two sheets 16, 19 and 17, 18 which have

been placed one upon the other and stuck together parallel to the fold edge. FIG. 3 likewise illustrates a sheet unit consisting of two sheets 16, 19 and 17, 18, which have been placed one inside the other and stuck together at the fold.

FIGS. 4 to 9 illustrate the device in accordance with the invention when parting a cross-folded sheet *a*. As FIG. 4 shows, the external pages 3, 4 of the sheet *a* are gripped in the vicinity of the fold edges 1, 2, by the suction elements of the pair of cylinders 7. In this context, the internal pages 5, 6, remain unparted, in particular in their area, so that the sheet *a* is not reliably dropped in the parted condition onto the conveyor chain 9 when ejected underneath from the pair of cylinders 7. To this end, as FIG. 5 illustrates, a ridge-shaped separator element 10 is disposed in front of the pair of cylinders 7, this element being attached to a lever 11 which pivots about the axis 13. The lever 11 is subjected to the effect of the tension spring 12 and has one arm 14 in contact with a cam 15. As FIG. 6 illustrates, the ridge-shaped separator element 10 is introduced into the gap between the cylinders, during the parting of the sheet *a*, and this forces the internal pages 5, 6 to spread apart right up to the end. As FIGS. 5 and 7 also illustrate, the cam 15 contains a recess; when the arm 14 is located in this recess (FIG. 5), the separator element is withdrawn from the gap between the cylinders, while in passing over the circular dwell portion of the cam, it is swung into the gap, as FIG. 7 indicates. The parting cylinders 7 and the cam 15 must, of course, run at the same speed and the cam 15 is so adjusted that with the sheet *a* in the position shown in FIG. 6 the separator element is pivoted into the gap between the cylinders and, with release of the sheet *a* by the cylinders 7, is retracted as shown in FIGS. 8 and 9.

FIGS. 10 and 11 illustrate the device in accordance with the invention when handling a sheet unit of the kind shown in FIGS. 2 and 3. As FIG. 10 shows, the parting takes place between on the one hand the sheet 16 and on the other the sheets 17 to 19, while in accordance with FIG. 11 the parting takes place between on the one hand the sheets 16, 18, 19 and on the other the sheet 17. In order to effect this differential kind of parting, the parting element 10, with its operating lever 11 and the cam 15, are arranged in a housing 20 which is mounted so as to be longitudinally displaceable upon the cam shaft 21 carrying the cam 15. As FIG. 12 indicates, the housing can be set in two end positions. To this end, a tension spring 22 is attached to one sidewall of the housing 20 while at the opposite sidewall, there engages the armature of a solenoid 23. The solenoid 23 can be energized and deenergized by the control system (not shown) of the machine, and when in the energized condition the separator element 10 is in the lateral position shown in full-time while with the solenoid deenergized, it adopts the position shown in the chain-dotted line. With the solenoid energized, therefore, parting of the sheets is carried out in accordance with FIG. 10, while with it deenergized, parting is carried out in accordance with FIG.

11.

I claim:

1. A device for spreading a sheet unit having a pair of external pages and at least one internal page sandwiched between said external pages, said device comprising:
 - spreading means including a pair of cylinders rotatable in opposite senses and provided with respective gripping means engageable with said external pages of a sheet unit for spreading them apart while advancing said sheet unit between said cylinders generally downwardly;
 - a conveyor below said cylinders adapted to receive the spread sheet unit upon its passage therebetween;
 - a pivotal ridge-shaped separator element adjacent said cylinders and swingable generally parallel to the axes thereof into a lower zone of the gap formed between said cylinders to deflect said internal page relative to another page of said sheet unit; and
 - drive means for pivoting said separator element intermittently and as a function of the cylinder speed.
2. The device defined in claim 1 wherein said drive means comprises a spring-loaded rocking lever carrying said separator element, and a cam rotatable as a function of cylinder speed for intermittently displacing said rocking lever.
3. The device defined in claim 2 wherein said drive means further comprises a housing receiving said cam and said rocking lever, a cam shaft extending generally transversely to said axes and driving said cam while shiftably carrying said housing, and mechanism for positioning said housing in two lateral terminal positions along said shaft.
4. The device defined in claim 3 wherein said mechanism includes a tension spring fixed to one transverse side of said housing and tending to draw said housing in one direction along said shaft and into one of said terminal positions, and a solenoid having an armature engaging an opposite side of said housing and energizable to draw said housing against said spring into the other of said terminal positions in an opposite direction along said shaft.
5. A method of spreading a sheet unit having a pair of external pages and at least one internal page sandwiched between said external pages, said method comprising the steps of:
 - bending said external pages outwardly while spreading them apart and simultaneously advancing said sheet unit along a transport path by engagement of said external pages;
 - during the bending of said external pages simultaneously deflecting and bending said internal page relative to another page of said unit independently of the engagement of said external pages, said internal page being bent and deflected by:
 - inserting a separator element between said internal page and said other page during the advance of said sheet unit; and
 - withdrawing said separator element from said sheet unit upon its release from said transport path.

55

60

65

70

75