

(19)



Europäisches Patentamt

European Patent Office

Office européen des brevets



(11)

EP 0 626 840 B1

(12)

EUROPEAN PATENT SPECIFICATION

(45) Date of publication and mention
of the grant of the patent:

03.12.1997 Bulletin 1997/49

(21) Application number: **93917809.1**

(22) Date of filing: **11.08.1993**

(51) Int. Cl.⁶: **A61G 7/14**

(86) International application number:
PCT/FI93/00315

(87) International publication number:
WO 94/09739 (11.05.1994 Gazette 1994/11)

(54) LIFTING AND TRANSPORTING WASH APPARATUS

HEBENDER UND TRANSPORTIERENDER WASCHAPPARAT

APPAREIL POUR SOULEVER ET POUR LAVER

(84) Designated Contracting States:
**AT BE CH DE DK ES FR GB GR IE IT LI LU MC NL
PT SE**

(30) Priority: **23.10.1992 FI 924804**

(43) Date of publication of application:
07.12.1994 Bulletin 1994/49

(73) Proprietor: **KORPELA, Viljo
SF-03100 Nummela (FI)**

(72) Inventor: **KORPELA, Viljo
SF-03100 Nummela (FI)**

(74) Representative:
**Feldmann, Paul David et al
Patentanwaltsbüro FELDMANN AG,
Kanalstrasse 17
8152 Glattbrugg (CH)**

(56) References cited:
**US-A- 4 435 863 US-A- 5 001 789
US-A- 5 148 557 US-A- 5 233 708**

EP 0 626 840 B1

Note: Within nine months from the publication of the mention of the grant of the European patent, any person may give notice to the European Patent Office of opposition to the European patent granted. Notice of opposition shall be filed in a written reasoned statement. It shall not be deemed to have been filed until the opposition fee has been paid. (Art. 99(1) European Patent Convention).

Description

Daily cleanliness forms an important aspect of patient care. When patients become incapable of cleaning themselves due to physical disabilities, help must be provided by others. This requires heavy physical work from the personnel of an institution. When for instance a patient is a large disabled person, several staff members become involved in moving the patient: nevertheless there remains a risk of personnel straining their backs or otherwise injuring themselves in the course of this process. Lifting persons manually, an action which may often exceed the capability of the person performing it, endangers both the patient and the helper. The difficulty of performing by conventional means cleaning and lifting duties may also jeopardise the level of hygiene, as personnel must rapidly carry out dangerous and heavy work activities.

Until now body cleaning has been performed using traditional methods and tools. Any available auxiliary machinery has usually turned out to be large, cumbersome, awkward and not well adapted to the task, which has meant that operating methods became conformant to the tools. Typical equipment includes shower baths, wash beds, wash benches, shower stretchers, shower wheelchairs and primitive washing stools. In spite of its unwieldiness this equipment must be used daily to maintain the hygiene of patients. Usually this equipment consists of separate devices, to which and from which the patient must be transported. The simpler and least expensive apparatus makes difficult even the most elementary toilet of the lower back, since the patient sits on these parts of the body which must be washed.

The Finnish patent 54227 describes a solution well adapted to the transport and light lower back toilet of a patient. The lift, transport and wash device presented by this invention improves markedly the toilet facilities for a patient and permits a full body wash while in a position ergonomically advantageous to the personnel.

Another lifting and transporting apparatus is shown in US-A-5.001.789. It describes a transport seat for transporting and washing a disabled or invalid patient mounted on an base frame by a connection with a swivel axis permitting a rotation of approximately one quarter of a circle wherein the connection to the frame is constructed to allow raising or lowering the seat and further comprising a foot support, a waist support and a safety belt for holding and securing the patient. The connection is mounted to the base frame near one end of it. The primary lifting device and the means for the rotating motion consists of a system of number of pivotable connected arms and hydraulic actuators so that the lifting and the rotation motion are performed together in one combined lifting and rotation motion.

Another lifting and transporting apparatus representing the closest prior art, is shown in US-A-4,435,863, which shows a transport seat for the purposes of lifting a patient from a bed and wheel chair. It is mounted on a base frame by a connection with a swivel

axis, wherein the connection to the frame is constructed to allow raising or lowering the seat and further comprising a foot support and a safety belt for holding and securing the patient. A primary lifting device is rotatably mounted to the swivel axis, so that the raising or lowering movement is independent from the rotation movement. Additionally chest pad and knee pad and a patient with it can be turned about an vertical axis sideways. A patient is secured by a safety belt against a chest pad and by a securing strap against a knee pad. The patient is held by these means in an embryonic position in the lifting and also in the pivoted position. This device is made to hold a patient only for a short time while lifting from bed, transporting to a wheel chair and lowering onto the wheel chair.

The aim of the present invention is to give a light and very simple construction for such a transport seat. A patient should be transportet in a normal sitting position and be turned for the purpose of washing into a lying position, which is very comfortable for the patient and for a washing person.

The lift, transport and wash device of this invention also removes efficiently and in a simple fashion the difficulties described earlier. Furthermore, its use increases the safety of both personnel and patient. This invention also augments the efficiency of patient care and thereby improves the relationships between patients and personnel. Care institutions also achieve economies through this invention: the workload of the personnel is reduced and excessively heavy exertions are eliminated, thus reducing the number of injuries and sick leaves, while job satisfaction increases. Patient care requires hygiene of the lower limbs more often than a full body wash, and this invention permits toilet at each visit to the lavatory.

Figures 1, 2, 3 and 4 show one possible materialisation of this invention.

Preparation for the use of this apparatus may begin by disrobing the patient safely and easily in bed. Then the patient may be brought over on his side with his legs bent at the knees towards the lateral railing of the bed, which has previously been lowered down. The patient may then be raised to a sitting position over the edge of the bed, as if he were sitting at the edge of the bed. The patient is then attached to the apparatus shown in Figure 1 and raised by it. He may then be moved with the lift, transport and wash apparatus to the lavatory, to toilet or to a washing facility.

Diagram 1 presents one realisation of this invention. The frame 1 rests on four freely turning wheels 2 and carries the primary lifting apparatus 4 through a raising device 3, which operates over a distance A. The primary lifting apparatus 4 may be locked in a transport position (shown in Figure 2) or turned by means of the handles 13 in the direction indicated by arrow B over approximately one quarter of a circle and locked to bring the patient into a washing attitude (show in Figure 3). The swivel axis 5 used by this operation has been selected to achieve a suitable height for washing and to

maintain proper balance of the apparatus. When the apparatus has been rotated by 90 degrees the patient may be brought in washing position by lowering the foot support 7 by means of the actuators 6 over a distance C, thus loosening the waist belt and leaving the patient to rest with his elbows against the support 10 and with his hips against the waist support 9 and his legs against the knee support 11 and the foot support 7, thereby providing him with a firm and secure brace in the lift, transport and wash apparatus (show in Figure 4). The waist support 9 prevents the bending of a disabled spine by being flexibly joined through a spring 12 to the support 10. The hip and safety belt 8 may be opened during the washing procedure. After washing the belt is secured. By using actuator 6 to move the foot support 7 in a direction opposite to arrow C, the patient is brought to a sitting position, the waist belt is clasped and the primary lifting apparatus 4 is turned upwards in a direction opposite to arrow B and locked. Then the patient may be moved in a sitting position to his bed or to another location.

A materialisation of this invention may obviously use different types of machine elements in order to provide the actions described. The location of the swivel axis 5 may also be altered, thereby changing the working position.

Claims

1. A transport seat for transporting and washing a disabled or invalid patient mounted on a base frame (1) by a connection of a primary lifting device (4) with a horizontal swivel axis (5), permitting a rotation of approximately one quarter of a circle, and with a raising device (3) arranged between the swivel axis (7) and the frame (1) near the center of the frame (1), and further comprising a knee support (11), a hip and safety belt (8), and a waist support (9),
characterized in that the waist support (9) is connected by a spring (12) to the primary lifting device (4), which further comprises a foot support (7) moveable with actuators (6) and an elbow support (10) so that, if the primary lifting device (4) is in the rotated position of about one quarter of a circle, the foot support (7) can be lowered.

Patentansprüche

1. Ein Transportsitz zum transportieren und waschen eines kranken oder invaliden Patienten, montiert auf einem Grundrahmen (1) mittels einer Verbindung mit einer primären Hebevorrichtung (4), welcher eine horizontale Schwenkachse (5) aufweist, und eine Drehung um annähernd einen Viertel eines Kreises erlaubt, und mit einer zwischen der Schwenkachse (5) und dem Rahmen (1), in der Nähe des Zentrums des Rahmens (1), angeordneten Höhenverstellung (3), und mit einer Kniestütze

(11) und einem Hüft- und Sicherheitsgurt (8) und mit einer Rumpfstütze (9), dadurch gekennzeichnet, dass die Rumpfstütze (9) mittels einer Feder (12) an der primären Hebevorrichtung (4) befestigt ist, und dass im weiteren eine Fusstütze (7) vorhanden ist, welche mittels eines Stellgliedes (6) bewegbar ist, und mit einer Ellbogenstütze (10) in der Weise, dass wenn sich der primäre Hebevorrichtung (4) in der, um etwa einen Viertel eines Kreises geschwenkten Stellung, befindet, die Fusstütze gesenkt werden kann.

Revendications

1. Siège de transport pour transporter et pour laver un patient handicapé ou invalide, monté sur un cadre de base (1) par une connexion d'un premier dispositif élévateur (4) avec un axe de pivotement horizontal (5) permettant une rotation d'environ un quart de cercle et d'un dispositif de redressement (3) disposé entre l'axe pivotant (5) et le cadre (1) à proximité du centre du cadre (1), et comprenant également un support pour genou (11), une ceinture pour les hanches et de sécurité (8) et un support pour la taille (9), caractérisé en ce que le support pour la taille (9) est connecté par un ressort (12) au premier dispositif élévateur (4) qui comprend également un support pour pied (7) pouvant être déplacé au moyen de dispositifs de commande (6) et un support pour épaule (10) de sorte que, si le premier dispositif élévateur (4) est dans la position tournée d'environ un quart de cercle, le support pour pied (7) peut être abaissé.

FIG. 1

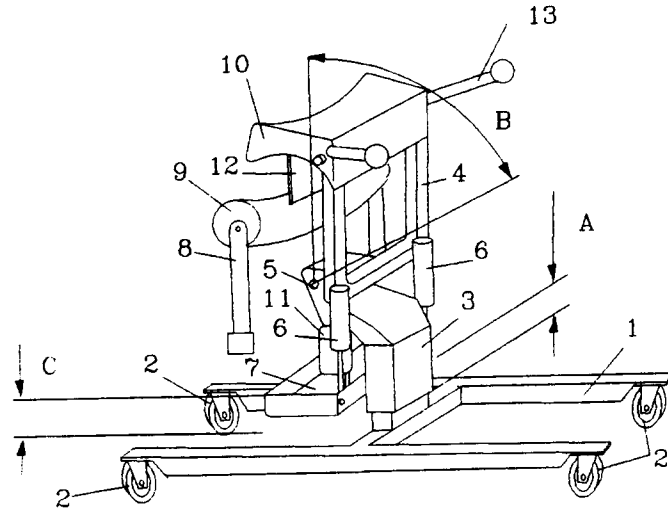

FIG. 2

FIG. 3

FIG. 4

