

C. H. HALL.

Improvement in Steam Vacuum-Pumps.

No. 131,524.

Fig. 1.

Patented Sep. 24, 1872.

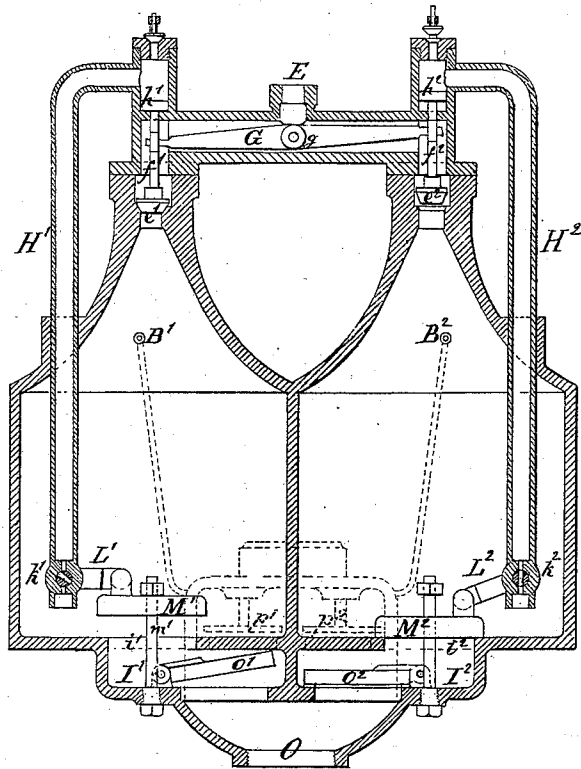
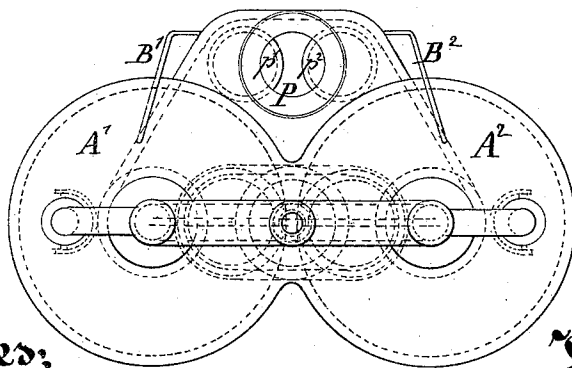

Fig. 2.



Witnesses;

Arnold Hornum.

W. C. Day

Inventor;

C. H. Hall
by his attorney J. S. Stebbins

UNITED STATES PATENT OFFICE.

CHARLES H. HALL, OF NEW YORK, N. Y.

IMPROVEMENT IN STEAM VACUUM-PUMPS.

Specification forming part of Letters Patent No. 131,524, dated September 24, 1872.

CASE J.

To all whom it may concern:

Be it known that I, CHARLES H. HALL, of New York city, in the State of New York, have invented a certain Improvement in Steam Pumping-Apparatus, of which the following is a specification:

To distinguish this from other inventions of my own, which are somewhat analogous, I will designate this particular invention by the letter J.

The apparatus belongs to that class of steam-pumps in which the solid working parts are small relatively to the capacity of the apparatus, and the steam is caused to act by direct pressure upon the water. This class is one of the earliest for elevating water by the pressure of steam. It is generally admitted to involve some loss of effect by condensation; but I have determined by experiment that that is not serious, while there is a marked gain by the reduction of rubbing surfaces, and the great efficiency and small cost of the apparatus.

The following is a description of what I consider the best means of carrying out the invention. The accompanying drawing forms a part of this specification.

Figure 1 is a vertical section, and Fig. 2 is a plan view.

Similar letters indicate like parts in all the figures.

$A^1 A^2$ are vessels of equal size, formed of cast-iron in one piece, and adapted to resist a strong internal pressure; as also to resist the external pressure of the atmosphere when a vacuum is formed therein. E is a steam-pipe which communicates with a boiler not represented. O is a pipe of sufficient size communicating with the tank or well from which the water is to be taken; and P is a delivery-pipe adapted to convey away the water under pressure.

The chambers A^1 and A^2 are filled alternately with steam and water. The action is self-controlling. When the steam is excluded from a chamber, the water is received from the pipe O and fills it. Meantime the opposite chamber is being emptied of its water by the steam entering at its top and pressing downward on the surface with such force as to discharge the water outward through the discharge-pipe. When the water is thus expelled the reception

of steam is cut off and the chamber is soon again filled with water. While one chamber is being filled with water, the other is expelling its water.

The source from which I derive the motive power to produce the proper changes in the positions of the valves at the period when the apparatus should change its condition from admitting steam on one side to admitting it on the other, is the force of the water in its discharge. I provide means which allow the water to be discharged quietly or without any influence upon the valves during the early portion of the discharge from each chamber, but at or near the close of each discharge, it becomes efficient and induces a strong movement of a part which, being properly connected, induces the shifting of the several valves.

The chambers $A^1 A^2$ receive the water from the water-induction or suction-pipe O through the valves $o^1 o^2$, which are placed at one side, as represented. The water is discharged through valves $p^1 p^2$, which are mounted on the opposite side of the main chambers $A^1 A^2$. The water flows through these latter valves, to wit, through the discharge-valves, by passing down from each of the main chambers $A^1 A^2$ into sub-chambers provided in the bed-casting below, which are marked respectively $I^1 I^2$ —that is to say, the water in its discharge from the chamber A^1 is compelled first to descend through an orifice which may be circular, and is indicated in Fig. 1 marked i^1 , into the chamber below, which is marked I^1 , and from this latter chamber it is discharged upward past the discharge-valve p^1 into the discharge-pipe P to be conveyed away. So also the water, in being discharged from the other main chamber A^2 , first flows downward through the passage i^2 into the sub-chamber I^2 ; and from thence flows past the discharge-valve p^2 into the pipe P. $M^1 M^2$ are floats which move vertically with the rising and sinking of the water to a limited extent. They are guided by the rods $m^1 m^2$ provided with a jam-nut or other suitable stop on the upper end of each, as represented. While the water is high in either chamber, A^1 or A^2 , these floats, $M^1 M^2$, are held by their buoyancy at such an elevation that they are of no effect; but when, by reason of the lowering of the water-surface, the floats cease to be supported at their highest eleva-

tion, and sink down, they soon come into a position where they are drawn down violently by the strong outward current which is flowing downward through the cavity below into the sub-chamber; and when this condition is reached they move rapidly downward and induce the desired change of conditions through agencies which will be described further on. The steam received through the pipe E is controlled in its admission to either chamber A¹ or A² by means of the valves e¹ e². These valves open upward, and each is provided with a stem which connects to a piston working moderately tight in a cylinder above. G is a pivoted beam, capable of rocking to a limited extent, mounted in the fork of the passage E. It turns on a central axis or pivot, g, and its ends take hold, respectively, of the stems f¹ f². The connection may be made in any convenient manner, so as to allow the slight motion necessary. I prefer to thin the ends of the lever G, and insert them through slots in the stems f¹ f². These stems may be widened, if desired, so as to allow for a considerable slot without weakening the stem. It will be readily seen that the closing of either of the steam-valves e¹ e² involves the opening of its mate. The spaces above the small pistons h¹ h² communicate through the pipes H¹ H² with a point near the bottom of the corresponding chambers A¹ A²—that is to say, the pipe H¹, open at both ends, leads from above the piston h¹ to near the base of the chamber A¹, and the pipe H² leads from the space above the piston h² to a point near the base of the chamber A². Near the lower end of each is a cock, which is connected with the neighboring float before described by means of a lever, as shown. These cocks control the flow of fluid through the respective pipes. The lever L¹ connects the float M¹ with the cock k¹ in the pipe H¹, and the corresponding connection is made in the opposite chamber by means of the lever L². In Fig. 1 the steam-valve e¹ is closed and the steam-valve e² is open. The steam flows freely from the pipe E past the valve e² into the top of the chamber A², and forces out the water. The water is delivered through the valve p² into the discharge-pipe P and conveyed away to be utilized. This operation induces a lowering of the surface of the water in the chamber A², but this induces no change in the position of the float M², nor of the connected cock k², until the water is nearly all expelled from the chamber. At this juncture a further lowering of the water-surface commences to lower the float M². So soon as this movement has progressed to such an extent as to lower the float M² until it comes within the influence of the current of water which is being discharged downward through the orifice i² the float M² is sucked down tightly into the said orifice, and a sudden change of the conditions of the entire apparatus ensues. This change of condition is initiated by this movement of the float M², through the agency of the lever L² and the stop-cock k², which

latter being opened widely by the sudden sinking of the float M² allows the steam which fills the chamber A² to flow upward through the pipe H², and to equalize the pressure on the two sides of the piston h². Under these new conditions the valve e² sinks into its seat. The lever G rocks on its center g, and the valve e¹ opens. By this series of changes the steam is permitted to flow into the chamber A¹ and induce a discharge of the water therefrom with a corresponding movement of the float M¹, and a corresponding change of conditions at the end of the movement. Meantime, while the chamber A¹ is being thus emptied, the chamber A² is being filled with water. Immediately on the closing of the steam-valve e², and the consequent exclusion of any further accession of steam to that chamber, the pressure therein may be assumed to commence to sink. This would ultimately result in a vacuum sufficient to induce the influx of water from below, but it is important to hasten its operation. For this purpose I provide each chamber with a small pipe open at each end, which communicates by a point near the top of the chamber with the discharge-pipe P or the connected passages—in other words, I allow a small stream of water to flow backward at will from the discharge-pipe, in which a pressure is always maintained, into either or both the main chambers A¹ A². The pipe which performs this service for the chamber A¹ is marked B¹. The pipe which performs the corresponding service for the chamber A² is marked B². So long as the pressure in the chamber A² remains greater than that in the delivery-pipe P there is no influx through the pipe B²; but the pressure, which is never much beyond that in the delivery-pipe P, is reduced almost instantaneously after the closing of the steam-valve e², so that cold water commences to flow backward through the pipe B². The current thus injected rapidly condenses the steam, and so soon as the pressure is sufficiently lowered a strong current of water from the suction-pipe O induces an opening of the proper induction-valve o², and an upward flow through the orifice i² into the chamber A², and fills it. The filling of the chamber lifts again the float M² to its original position and closes the cock k².

The description of the operation on one side answers, of course, for the other.

It will be understood that the two sets of the apparatus are exact counterparts of each other. One chamber, A¹, fills with water while the other chamber, A², empties. I prefer to so construct the apparatus that the filling of one chamber with water will be completed a little before the emptying of its mate, so that it will wait a very little time in the filled condition.

It is not essential to the success of my apparatus that the pieces M¹ M² be capable of floating on the water. It is only necessary that they shall present extended surfaces subject to the influence of the water, so that they shall be moved actively to a proper extent at

the moment when the water is nearly discharged, and remain practically inoperative at the earlier periods. Any movable device which is of about the same weight as the water may serve, provided it is held, by friction or other cause, against sinking until it ceases to be supported by the water. It is important that it shall be subjected, at the right point, to the influence of the current. If it floats it is certain to stay up out of the influence until the water-line is lowered. If it is not exactly afloat the strong induction of the current of water is certain to lift it.

I have devised this apparatus as the result of much and expensive experiments. In case of difficulty from the air, which is liable to accumulate by repeated condensations of the steam, I propose to attach a provision for expelling a small quantity of the fluid from the top of each chamber after each filling with water by allowing it to pass out under a loaded valve in a side pipe, not represented. The force available for this purpose may be the sudden increase of pressure, analogous to that in a water-ram, which is experienced when the influx of water is suddenly stopped. In case such cause is found to disturb the valves $e^1 e^2$ and cause them to open too soon I can use check-valves below the latter. I can face the valves or seats by tools, or with India rubber.

The form of many of the parts may be variously modified; but I esteem it important that the tops of the chambers $A^1 A^2$ be tapered, as shown, so that on first admitting the steam to the chamber it will strike only on a small surface, and will immediately heat it. The surface of the water should not be agitated by the influx of the steam; but it is well to cause the influx of the water from the water-pipe O to be directed so as to agitate the water-surface, as otherwise a very slow action of the pump may be defeated by the steam in the

chamber refusing to be condensed by the hot stratum on the surface, and if one of the steam-valves e^1 or e^2 should leak a very little the pump may stop unless this agitation during and by the influx of the water is provided for.

Under ordinary conditions the small valves opening outward over each piston $h^1 h^2$ will suffice to discharge sufficient steam, and each at each operation, to rid the apparatus of air. At each operation steam flows up through the pipe H^1 or H^2 , and the surplus above the atmospheric pressure mainly flows out into the atmosphere through the small valve at the top, leaving the remainder only to be condensed.

Where corresponding mechanisms are used on each side of the apparatus a claim for one side will be understood to apply to either or both.

I claim as my invention—

1. The float or movable piece M^1 , connected to the cock k^1 , and arranged, as shown, relatively to the orifice i^1 so as to suddenly open the cock and induce the closing of the steam-valve e^1 when the water is nearly discharged from the chamber A^1 , as specified.

2. The lever G and valves $e^1 e^2$, with their connections, arranged and operating relatively to each other and to the steam and water chambers A^1 and A^2 , as herein specified.

3. The passage H^1 , provided with suitable controlling means k^1 , in combination with the steam-induction valve e^1 , so as to insure the closing of the steam-valve by the exhaust steam from the steam and water chamber A^1 , as herein specified.

In testimony whereof I have hereunto set my hand this 18th day of May, 1872, in the presence of two subscribing witnesses.

C. H. HALL.

Witnesses:

ARNOLD HÖRMANN,
W. C. DEY.