

M. A. BOGGESS.
MOP WRINGER.
APPLICATION FILED DEC. 11, 1916.

1,234,721.

Patented July 31, 1917.

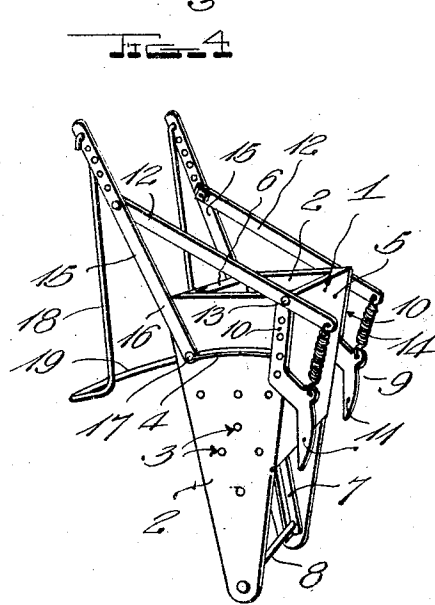
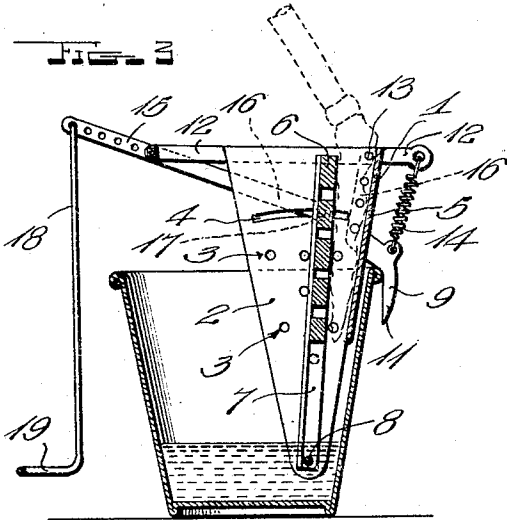
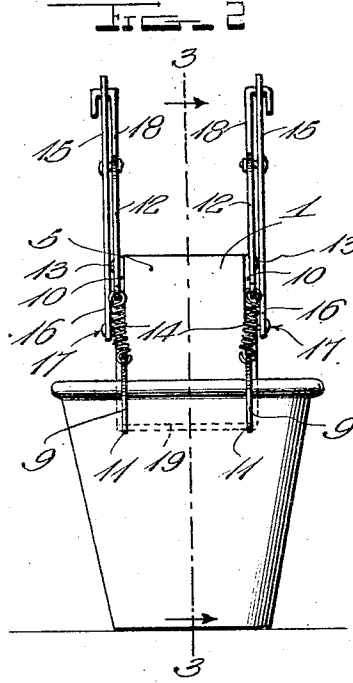
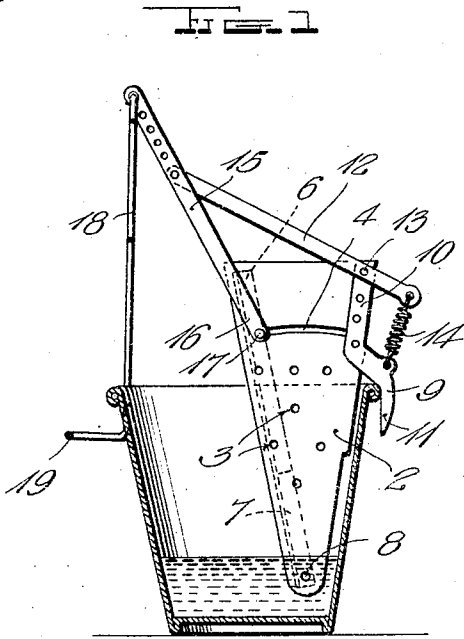

Inventor

M. A. Boggess

Witness

E. C. ...

By

A. B. ...

Attorneys

UNITED STATES PATENT OFFICE.

MARGARET A. BOGGESS, OF FOND DU LAC, WISCONSIN.

MOP-WRINGER.

1,234,721.

Specification of Letters Patent.

Patented July 31, 1917.

Application filed December 11, 1916. Serial No. 136,281.

To all whom it may concern:

Be it known that I, MARGARET A. BOGGESS, a citizen of the United States, residing at Fond du Lac, in the county of Fond du Lac and State of Wisconsin, have invented certain new and useful Improvements in Mop-Wringers; and I do declare the following to be a full, clear, and exact description of the invention, such as will enable others skilled in the art to which it appertains to make and use the same.

This invention relates to new and useful improvements in mop wringers, and the primary object of the invention is to provide a mop wringing apparatus adapted to be placed in a suitable receptacle, and be operated by the pressure of the foot of the operator, whereby it will so engage the mop as to effectively press the same to wring all the water therefrom.

Another object of the invention is to provide a mop wringer of this character having means whereby when the apparatus has been operated, and the same is released, it will spring back to its normal open position and the mop may be easily removed therefrom.

A further object of the invention is to provide an apparatus of this class which will embody the desirable features of simplicity, cheapness, ease of application, and efficiency of operation.

With these and other objects in view, the improvement resides in the construction, combination and arrangement of parts set forth in the following specification and claims.

In the accompanying drawings:—

Figure 1 is a side elevation of the mop wringer applied to a receptacle, showing the receptacle in vertical section;

Fig. 2 is an end elevation of the wringer and receptacle;

Fig. 3 is a vertical section on the line 3—3 of Fig. 2; and

Fig. 4 is a detail perspective of the wringer.

In describing my invention I shall refer to the accompanying drawings in which similar reference characters designate corresponding parts throughout the several views. The numeral 1 designates a casing for the apparatus which is substantially rectangular-shaped having one of its sides open. The two opposite side portions 2 of the casing 1 are perforated, as shown at 3 and pro-

vided with alining transversely extending slots 4. The side of the casing 1 that is positioned between the oppositely disposed side portions 2, and which is designated by the numeral 5, forms a stationary presser member against which the mop is pressed when the device is operated.

The casing 1 has positioned therein a movable presser member 6 which forms a closure for the open side thereof, and which is adapted to swing back and forth against the stationary presser member or closed side 5. This movable presser member 6 is provided with a pair of downwardly projecting arms 7 which are pivotally mounted on a hinge bar 8 extending across the casing and mounted in the oppositely disposed sides 2 of the same.

The casing 1 is supported in the receptacle by means of a pair of hangers 9 which are provided with straight portions 10 secured to the sides 2 of the casing adjacent the top of the same, and with outwardly bent hooked portions 11 that are adapted to be positioned over the edge of the receptacle. By this means the casing 1 may be positioned in any receptacle, such as a pail, washing tub, etc., so that when the mop is squeezed, the water therefrom will drop down through the open bottom of the casing into said receptacle.

A pair of substantially horizontally disposed levers 12 are fulcrumed intermediate their ends to the sides of the casing, as shown at 13, and these levers have one of their ends connected by coiled springs 14 with the hooked portions 11 of said hangers, to normally hold the other ends of the levers in raised position.

Fulcrumed to the free or last mentioned ends of the levers 12 is a pair of additional levers 15 which extend at an angle to said first mentioned levers, and which have their lower ends 16 pivotally connected with the opposite sides of the movable presser member 6 through the slots 4 in the sides 2 of the casing, as clearly shown at 17. These levers 15 are provided with a plurality of longitudinally spaced apertures to adapt them to receive the free ends of the levers 12 at the desired point depending upon the length of the levers 12 and 15 and the thickness of the mop to be squeezed. It will thus be seen that the fulcrums of the levers 15 are adjustable longitudinally of the latter.

The device is operated by means of sub-

stantially U-shaped presser stirrup 18 which has its free ends secured to the upper ends of the levers 15 and which is provided with a lateral offset 19 at the bottom of the same.

5 This stirrup is adapted to receive the operator's foot to operate the apparatus.

In operation, the mop wringer is positioned in a receptacle by placing the hangers 9 over the edge of the same, and when in normal position as clearly shown by Fig. 1 of the drawings, the ends of the levers 12 will be raised, and the stirrup 18 will be positioned a considerable distance above the ground. To operate the wringer after the mop has been placed within the casing between the stationary presser member and the movable presser member, the operator places his foot in the stirrup and forces downwardly whereupon the levers 15 and 12 will be folded down to the position shown in Fig. 3 of the drawings and consequently the movable presser member 6 will be moved against the stationary presser member, and the mop will be squeezed to force the water therefrom.

The perforations in the opposite sides of the casing allow the water to pass there-through, most of it, however, passing through the bottom of the casing. As soon as the operator's foot is released from the stirrup, the coiled springs 14 which are expanded when the device is operated, will pull the ends of the levers to which they are secured, downwardly, consequently raising the opposite ends of said levers, and the levers 15 will bring the presser member back to its normal position.

From the foregoing description of the construction of my improved mop wringer, the manner of applying the same to use and the operation thereof will be readily understood, and it will be seen that I have provided a simple and efficient device for carrying out the objects of the invention.

The various parts of this device may be made of any desirable material, but are preferably constructed entirely of sheet steel stampings. The extreme simplicity of construction enables it to be very inexpensively manufactured, and this device is applicable to various sizes of receptacles. The plurality of openings in the levers 15 allow these levers and the levers 12 to be adjusted for the purpose of which is obvious.

I claim:—

1. A mop wringer comprising a stationary presser member, a movable presser member, a lever fulcrumed intermediate its ends, an additional lever fulcrumed to said first mentioned lever, one end of said additional lever being operatively connected with the movable presser member, a foot engaging

operating member depending from said additional lever, and a coiled spring operatively connected to the first mentioned lever to normally hold the latter, and through the medium of the additional lever, the movable presser member, in its retracted position.

2. A mop wringer comprising a stationary presser member, a movable presser member, a lever fulcrumed intermediate its ends, an additional lever fulcrumed intermediate its ends to said first mentioned lever, one end of said additional lever being operatively connected with the movable presser member, a foot engaging operating member depending from the other end of said additional lever, and a coiled spring operatively connected to the first mentioned lever to normally hold the latter, and through the medium of said additional lever, the movable presser member, in its retracted position.

3. A mop wringer comprising a stationary presser member, a movable presser member, a lever having a relatively fixed fulcrum intermediate of its ends, a coiled spring connected to one end of said lever to normally hold the other end raised, an additional lever fulcrumed to said first mentioned lever, the fulcrum of said additional lever being adjustable longitudinally of the latter, the lower end of said additional lever being pivoted to one side of the movable presser member, and a stirrup depending from the upper end of said additional lever.

4. A mop wringer comprising a substantially rectangular-shaped casing having one side open, the two oppositely disposed side portions of the casing having slots therein, the remaining side of the casing forming a stationary presser member, a movable presser member positioned between said oppositely disposed sides of the casing, hangers secured to said side portions, a pair of levers fulcrumed intermediate their ends to said sides, coiled springs connecting one end of said levers and said casing for holding the other ends of said levers in raised position, an additional pair of levers fulcrumed on the upper ends of the first mentioned levers, the lower ends of said additional levers being pivotally connected with the movable presser member through the slots in the sides of the casing, and a substantially U-shaped stirrup depending from the upper ends of the levers.

In testimony whereof I have hereunto set my hand in the presence of two subscribing witnesses.

MARGARET A. BOGGESS.

Witnesses:

MAMIE KINNEY,
J. M. GOODING.