

E. SEGET.
 ELECTRIC SIGNAL.
 APPLICATION FILED JUNE 8, 1909.

1,007,243.

Patented Oct. 31, 1911.

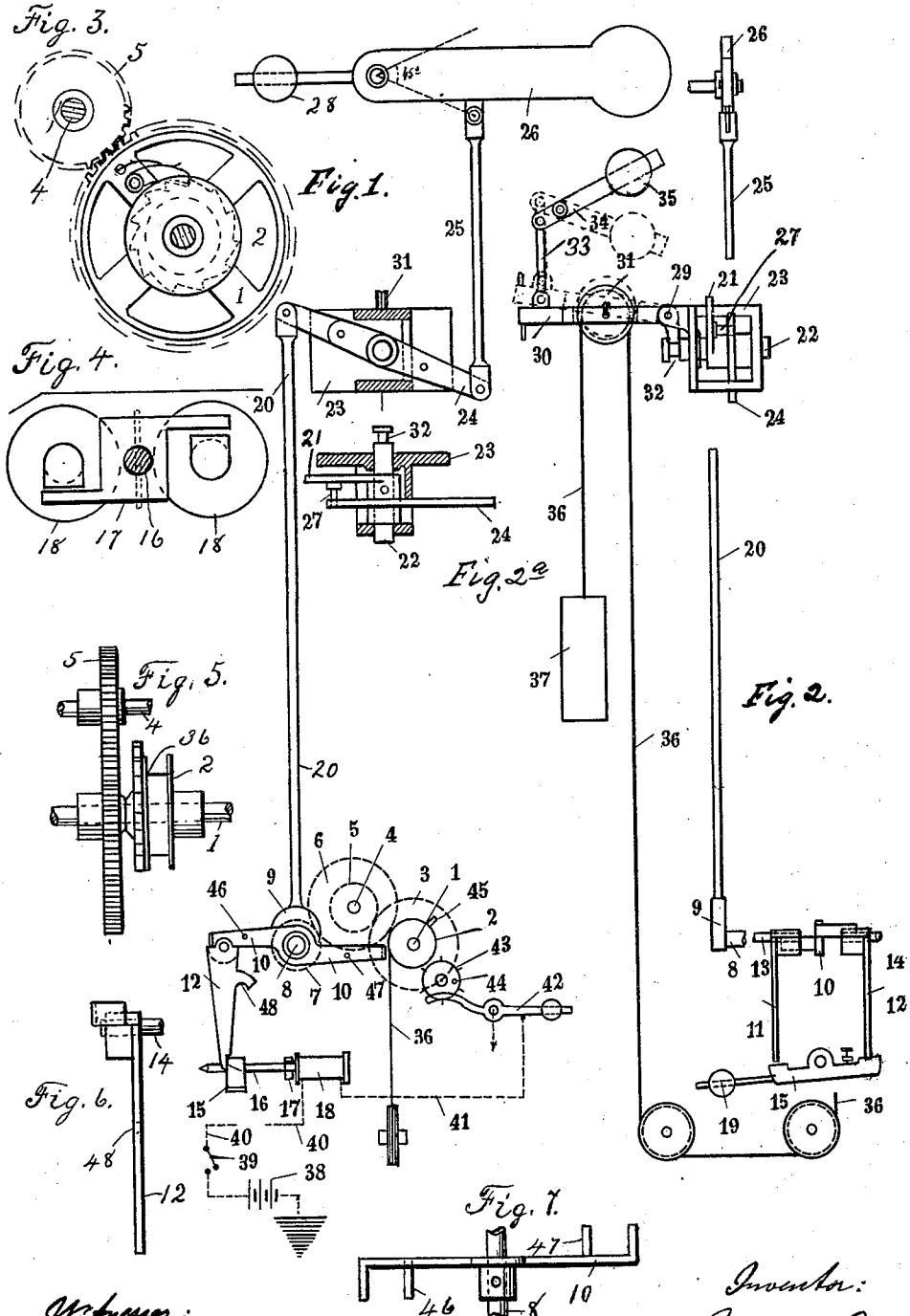

Witness:
 F. Dittmar
 W. Hallaband

Inventor:
 Edward Seget
 by G. Dittmar
 attorney.

UNITED STATES PATENT OFFICE.

EDWARD SEGET, OF WARSAW, RUSSIA.

ELECTRIC SIGNAL.

1,007,243.

Specification of Letters Patent.

Patented Oct. 31, 1911.

Application filed June 8, 1909. Serial No. 500,942.

To all whom it may concern:

Be it known that I, EDWARD SEGET, engineer, residing at 66 Wspólna street, Warsaw, Poland, Russia, have invented certain new and useful Improvements in Electric Signals; and I do hereby declare the following to be a full, clear, and exact description of the invention, such as will enable others skilled in the art to which it appertains to make and use the same.

This invention relates to a signal actuated by means of weights which signal on closing an electric circuit is moved by means of the actuating mechanism to "safety" and on breaking the circuit into "danger".

The essential feature of the invention consists in the special locking means more particularly set forth in the claim.

In the accompanying drawings which form part of this specification, Figure 1 represents a side elevation, partly in section. Fig. 2 an end view. Fig. 2^a is a detail in section through the standard showing the shaft and the levers thereon. Fig. 3 is a detail showing the connection of the drum with the gear. Fig. 4 is a detail view of the anchor. Fig. 5 is an edge view of Fig. 3. Fig. 6 is an edge view of the supporting lever. Fig. 7 is a plan view of the double armed lever.

Like numerals of reference indicate like parts in the several views.

On the shaft 1 is mounted a drum 2 intended to carry a wire rope 36. On the same shaft 1 is loosely mounted a pinion 3 which is connected by a ratchet wheel and a locking wheel with the drum 2. On the second shaft 4 are mounted two pinions the smaller 5 of which engages with the pinion 3 and the larger with the pinion 7 mounted on the third shaft 8. On this shaft 8 is mounted an eccentric 9 and a flat double armed lever 10. The ends of this lever are bent in opposite directions and the lever may rotate in a plane midway between those of two supporting levers 11 and 12 which are loosely mounted on the shafts 13, 14. The levers 11 and 12 have at their upper ends bosses the upper halves of which are of small diameter and the lower halves of large diameter so that on both sides small faces are formed. The lower ends of the levers 11, 12 may rest on a cross-bar 15 mounted on the shaft 16. On the same shaft is mounted the Z-shaped armature 17 of an

electro-magnet 18. In the position of rest that is in the "danger" position of the signal the cross-bar 15 under the action of the weight 19 is in a position in which it supports the lever 12 and since the end of the lever 10 now lies on the face of the boss of the lever 12 the whole mechanism is locked in its position of rest.

Adjacent the drum 2 is arranged a pinion 43 and on the drum is secured a pin 45. On each rotation of the drum the pinion 43 moves around to the extent of one tooth the number of times it is moved depending on the number of rope windings on the drum. After a certain number of rotations a pin 44 on the face of the pinion 43 presses on the arm of the lever 42 whereby the connection of the conductor 41 with the earth is interrupted.

On the lever 10 on opposite ends are arranged two pins 46 and 47 and on the levers 11 and 12 are arranged projections 48. On rotation of the lever 10 the pin 46 or 47 presses against the corresponding projection 48 and thus the end of the lever 11 or 12 passes beyond the cross-bar 15.

The eccentric rod 20 is connected with the end of the lever 21 which is mounted on the shaft 22. This shaft is mounted in a standard 23 which is secured on the signal post close to the semaphore arm. On the shaft 22 is also loosely mounted a second lever 24 which is connected by the rod 25 with the semaphore arm 26. On the lever 21 is secured the pin 27. If the end of this pin enters a corresponding orifice in the lever 24 these two levers are connected together.

The weight 28 almost balances the semaphore arm, but not quite: the arm being the heavier. In an opening in the standard 23 on the spindle 29 is arranged a double armed lever 30 on the long arm of which the roller 31 is mounted, while the short arm rests in a neck 32 on the end of the shaft 22. The longer arm of the lever 30 is connected by the rod 33 with the double armed lever 34 on the end of which the counter balance weight 35 is arranged. The wire rope 36 passes from the drum 2 over the deflecting rollers inside the post onto the roller 31. From its end hangs a weight 37. The current of the electro-magnet passing from the battery 38 is closed and interrupted by the switch 39.

In Figs. 3 and 4 is shown the connection

of the drum 2 with the gear 5. On the drum 2 a ratchet is fastened and corresponding with this, a catch with a spring is secured on the gear wheel 3. The drum 2 is keyed to the shaft 1 whereas the gear wheel 3 is loosely attached to the same. The weight 37 in descending, takes, by the aid of the ratchet and catch, the gear wheel 3 along which engages the gear wheel 5. When the weight 37 ascends or rather when the works are wound up by the crank, only the shaft 1 with the drum 2 turns and the gear wheel 3 remains in its position, as by the turning of the drum in this direction the ratchet does not engage the catch but slides under it and lifts it a little.

In Fig. 4, the anchor and its position relatively to the poles of the electromagnet are shown.

The current-circle can be easily understood. The current flows from the positive pole of the battery 38 (its negative pole is connected with the earth) over the switch 39 to the conductor 40, then through the electro-magnet 18 of the device to the conductor 41. The latter is connected with the lever 42, the latter is also connected with the earth and thereby the current is completely closed.

If it is desired to place the signal at "safety" the switch 39 is closed. The current then passes through the conductor 40, the electro-magnet 18, through the conductor 41, the lever 42, and to earth back toward the battery. The electro-magnet attracts the armature 17. The cross-bar 15 is thereby moved through a certain amount and the supporting lever 12 released. The end of the lever 10 now loses its support and the whole mechanism is set in operation by the weight 37. On the commencement of the motion the lever 10 presses with its end on the face of the boss of the lever 12 which now swings out. When the lever 10 has passed over the boss, the pin 46 by pressure on the projection 48 brings the lever 12 back into its original position. After one rotation through 180° the other end of the lever 10 rests on the face of the boss of the lever 11. The motion of the mechanism is stopped and the semaphore arm remains at "safety."

In order to move the signal into "danger" the circuit must be interrupted. The cross-bar 15 then moves back into its original position, the supporting lever 11 being now released. The lever 10 again releases the mechanism which draws the arm into "danger." After rotation through 180° the lever

10 is held by the supporting lever 12 and the mechanism comes to rest.

As the current passing through the electro-magnet can be interrupted by the lever 42 the semaphore arm is also drawn into "danger" when the last coil of rope runs off the drum 2. It then presses the pin 44 against the lever 42 and thus interrupts the connection 41. Should this occur during the movement of the signal into "safety" the semaphore arm is raised out of "danger" into "safety" and drops back immediately into "danger." The signal now remains inoperative until the mechanism is again wound up. This action—the raising and lowering of the semaphore arm—takes place also in the case when an atmospheric discharge on account of a short rush of current excites the electro-magnet whereby the armature is attracted.

If the rope 36 breaks, the long arm of the lever 30 is raised by the weight 35 and the rod 33, the short arm of the same lever 30 moving the shaft 22 with the lever 21 mounted thereon. The pin 27 connected to the lever 21 is thereby drawn out of the opening in the lever 24 the connection is released and the semaphore arm drops under the action of the excess of weight into "danger," it being understood that the lever 21 is rigidly connected to the shaft 22 and the lever 24 but loosely.

Having now particularly described and ascertained the nature of my said invention and in what manner the same is to be performed, I declare that what I claim is:—

In an adjusting device for railway signals, a signal, means for operating said signal including a weight and connections between said weight and said signal, a double armed lever having its ends oppositely bent, said lever secured to a shaft, said shaft being included in said connections between the weight and signal, two supporting levers, the ends of which are adapted to be alternately engaged by the bent ends of the double armed lever upon its movement, electrically operated means for alternately releasing said supporting levers and means operated on the movement of said double armed lever for returning the respective supporting levers to normal position after their respective movements.

In testimony whereof, I affix my signature, in presence of two witnesses.

EDWARD SEGET.

Witnesses:

STANISLAW PORKSCZY,
CYRILL TREDNICKE.