

E. A. Turner

Steering.

N^o 54,824.

Patented May 15, 1866.

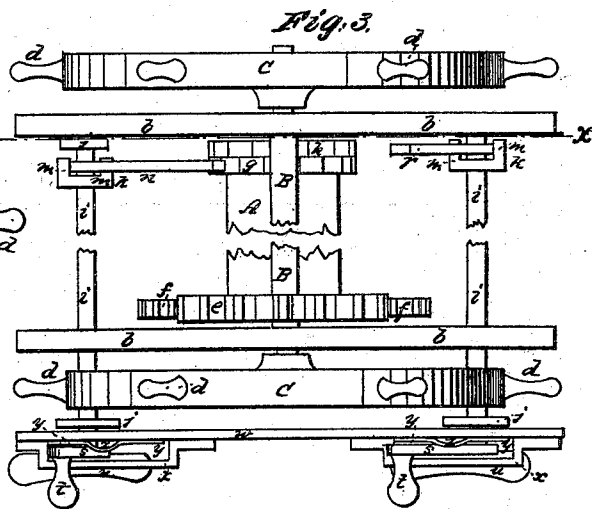
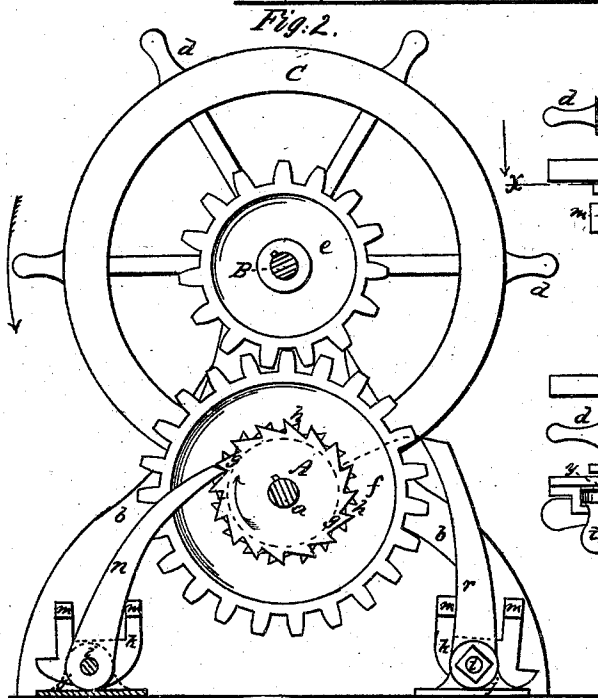
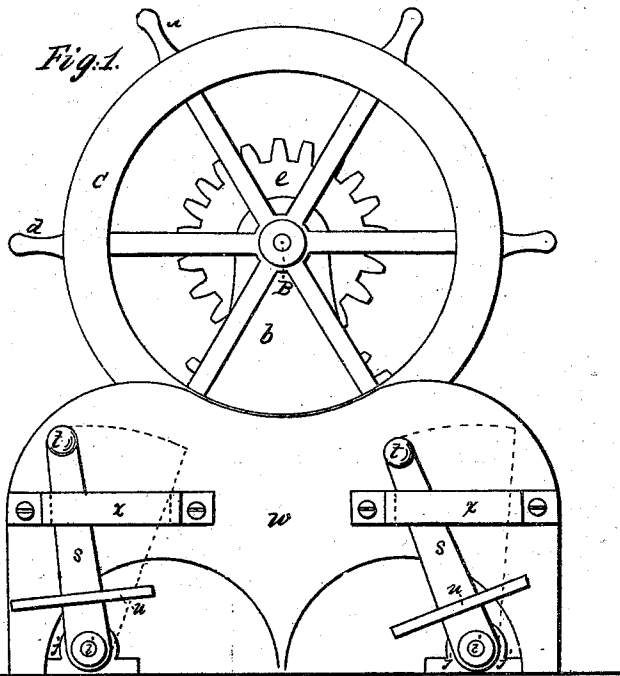

Witnesses.
J. A. Leggat
Henry J. Brown

Inventor
Ed. A. Turner

UNITED STATES PATENT OFFICE.

EDWARD A. TURNER, OF NEW YORK, N. Y., ASSIGNOR TO HIMSELF AND JOHN A. LEGGAT, OF BRANFORD, CONNECTICUT.

IMPROVED STEERING APPARATUS.

Specification forming part of Letters Patent No. 54,824, dated May 15, 1866.

To all whom it may concern:

Be it known that I, EDWARD A. TURNER, of the city, county, and State of New York, have invented certain new and useful Improvements in Steering Apparatus for Ships and other Vessels; and I do hereby declare that the following is a full, clear, and exact description of the same, reference being had to the annexed drawings, making a part of this specification, in which—

Figure 1 is an end elevation of a steering apparatus constructed according to my invention. Fig. 2 is a vertical transverse section taken in the line *x x* of Fig. 3, and looking in the direction of the arrow. Fig. 3 is a plan or top view.

Similar letters of reference indicate corresponding parts in all the figures.

This invention is designed to lessen the severe exertion heretofore required in working the steering apparatus of ships and other vessels, and to prevent the steersman from being thrown over the wheel or otherwise injured by the jerking thereof from the action of the rudder; and it consists in a novel arrangement of two locking-pawls, with frames for operating the same, with reference to two ratchet-wheels secured upon the drum of the apparatus, whereby the said drum may be prevented from turning in either or both directions, in order to retain the rudder in any desired position.

The invention further consists in a novel arrangement of parts by which the aforesaid pawls may be brought into or out of contact with the ratchet-wheels, when desired, by the hand or foot of the steersman.

To enable others to understand the construction and operation of my invention, I will proceed to describe it with reference to the drawings.

A is the horizontal drum of the steering apparatus, the shaft or axle *a* of which works at each end in suitable bearings formed in the vertical standards *b*, situated one at each end of the said drum.

B is a shaft, which is placed above the drum A, and works in bearings formed in the upper ends of the standards *b*, and has a wheel, C, fixed upon one or both of its ends, the said wheels being furnished with handles *d*. The

shaft B is geared with the drum A by spur-wheels *e* and *f*, so that by turning the wheels C by means of their handles *d* a rotary motion in either direction may be given to the said drum to operate the chain or rope which works the rudder.

Fixed upon one end of the drum A, preferably upon that opposite the spur-wheel *f*, are two ratchet-wheels, *g h*, the teeth of which point in opposite directions, as clearly shown in Fig. 2.

Situated longitudinally on each side of the apparatus, and near the floor or deck to which the said apparatus is secured, is a horizontal shaft, *i*, which works in boxes or bearings *j*, firmly attached to the said floor. Rigidly secured upon each of the said shafts *i* is an upright piece or frame, *k*, the upper end of which is forked and turned over horizontally at right angles to its upright portion, as clearly shown at *m m* in Fig. 3.

Pivoted upon each of the shafts *i* is a pawl, which extends upward between the prongs *m* of the horizontal forked portion of the frame *k*, the distance between the said prongs being somewhat greater than the width of the pawl, so that the pawl may have a slight movement between the prongs. These pawls are marked respectively *n* and *r*, and are so placed upon their shafts *i* that while the pawl *n* acts upon the ratchet-wheel *g* the pawl *r* acts upon the ratchet-wheel *h*.

Rigidly attached to one end of each shaft *i* is an upright lever, *s*, which may be provided with a knob or handle, *t*, and has formed upon it at its lower end a transverse treadle, *u*, so that by moving the lever *s* by hand, or by pressing downward upon one end or the other of the treadle *u*, the shaft *i* may be turned to bring its attached pawl into or out of contact with its ratchet-wheel, as will be presently more fully explained.

w is a vertical plate situated transversely at the end of the apparatus on the inner side of the levers *s*, and firmly secured upon the outer side of this plate are two straps or clasps, *x*, between which and the vertical plate *w* the levers *s* are allowed to work, as fully shown in Figs. 1 and 2, the clasps preventing the lever from being twisted out of place.

Secured upon the plate *w*, at the inner side

of each lever *s*, is a spring, *y*, which presses outward against the lever, and has an outward curve or bend, *z*, in its center, which acts as a stop to hold the lever at one end or the other of the said spring, according as the pawl connected therewith is in or out of contact with its ratchet-wheel.

The wheel C is turned by means of its handles *d*, and operates the apparatus to move the rudder to any desired position in the usual way. When it is desired to hold the rudder stationary in such position the steersman moves the levers *s* inward toward each other, either by operating the said levers by hand or by pressing downward upon the inner ends of the treadles *u*, thus turning the shafts *i* and frames *k* to bring the upper ends of the pawls *n r* in contact with their respective ratchet-wheels *g h*, and thus prevent the drum A from turning in either direction, the levers being retained in place by the curved portions *z* of the springs *y*, which act as stops to prevent the levers from being turned back from slight causes, and are yet sufficiently yielding to allow them to pass when moved by the steersman.

When it is desired to release the drum A in order to change the position of the rudder the levers *s* are moved outward, either by hand, as just mentioned, or by pressing the outer end of the treadle *u* downward by the foot, so that the pawls are brought clear of the ratchet-wheels and the drum is allowed to turn in either direction.

When it is desired to prevent the drum from

turning in one direction only, one or the other (as desired) of the pawls is brought in contact with its corresponding ratchet-wheel, thus stopping the drum from moving in one direction and allowing it to rotate in the opposite direction. The pawl, being narrower than the space between the prongs *m* of the frame *k*, as hereinbefore mentioned, has a slight movement therein to allow the ratchet-teeth to pass beneath it during such rotation of the drum.

By thus locking the rudder in any desired position the steersman is not only relieved from the severe exertion of holding it by manual force alone, but is rendered much less liable to injury from the sudden strain and jerking of the wheel by the movements of the rudder in storms or rough weather.

What I claim as new, and desire to secure by Letters Patent, is—

1. The pawls *n r* and the frames *k*, arranged and operating with reference to each other and with the two ratchet-wheels *g h* on the drum of the apparatus, substantially as herein set forth, for the purpose specified.

2. The levers *s*, provided with treadles *u*, or their equivalents, operating the pawls *n r*, in connection with the ratchet-wheels *g h*, substantially as hereinbefore set forth, for the purpose specified.

ED. A. TURNER.

Witnesses:

J. A. LEGGAT,
HENRY T. BROWN.