



(72) STEINKE, THOMAS A., US

(72) ROSS, STEPHEN O., US

(71) STEINKE, THOMAS A., US

(51) Int.Cl.<sup>6</sup> A61F 2/06

(30) 1998/02/17 (09/024,571) US

(54) **PROTHESE ENDOVASCULAIRE EXTENSIBLE**

(54) **EXPANDABLE STENT**

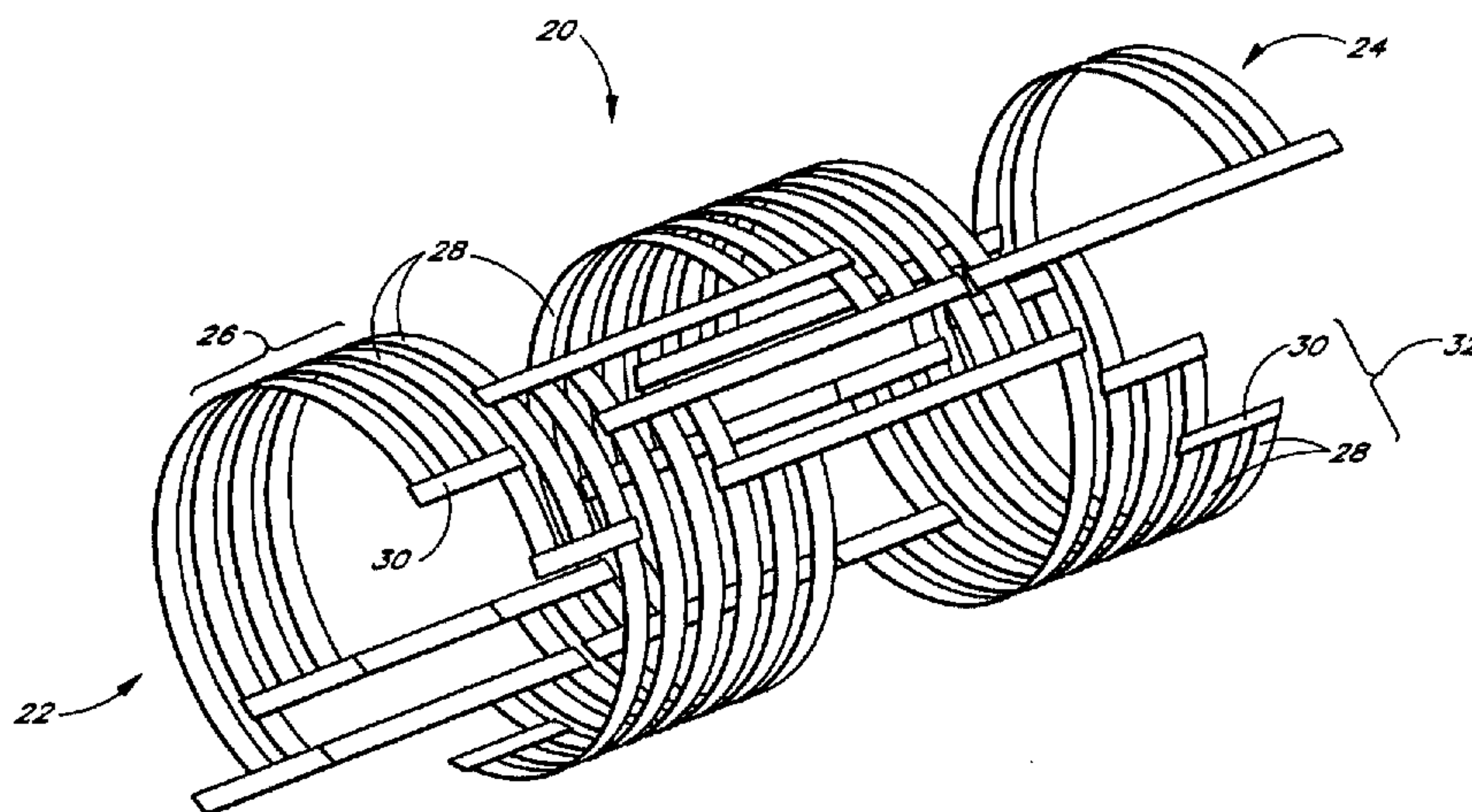

(57) La présente invention concerne une prothèse endovasculaire (20) de support de lumière destinée à être utilisée dans une artère ou n'importe quelle lumière du corps. La prothèse endovasculaire comprend une pluralité d'éléments d'échelle (32) présentant des nervures allongées (28) courbées pour définir un arc circonferentiel de l'élément tubulaire ainsi que des échelons terminaux (30) fixés aux nervures allongées. Les nervures allongées d'éléments d'échelle adjacents sont sensiblement parallèles les unes aux autres et viennent en contact coulissant avec les échelons terminaux d'éléments d'échelle adjacents. Le coulisement des échelons terminaux le long de l'arc circonferentiel défini par les nervures en contact crée une distance circonferentielle variable entre les échelons terminaux d'éléments d'échelle adjacents. Par conséquent, la prothèse endovasculaire présente un premier diamètre dans lequel la distance circonferentielle entre les échelons terminaux d'éléments d'échelle adjacents est réduite, et un second diamètre variable dans lequel la distance circonferentielle entre les échelons terminaux d'éléments d'échelle adjacents est allongée.

(57) The present invention provides a lumen support stent (20) for use in an artery or any body lumen. The stent is formed from a plurality of ladder elements (32) having elongated ribs (28) bowed to define a circumferential arc of the tubular member and end rungs (30) affixed to the elongated ribs. The elongated ribs of adjacent ladder elements are substantially parallel to one another and slidably engaged by the end rungs of adjacent ladder elements. Sliding of the end rungs along the circumferential arc defined by the engaged ribs creates a variable circumferential distance between the end rungs of adjacent ladder elements. Consequently, the stent has a first diameter in which the circumferential distance between end rungs of adjacent ladder elements is collapsed, and a variable second diameter in which the circumferential distance between end rungs of adjacent ladder elements is expanded.

**PCT**WORLD INTELLECTUAL PROPERTY ORGANIZATION  
International Bureau

INTERNATIONAL APPLICATION PUBLISHED UNDER THE PATENT COOPERATION TREATY (PCT)

<p>(51) International Patent Classification <sup>6</sup> : <b>A61F 2/06</b></p>	<p><b>A1</b></p>	<p>(11) International Publication Number: <b>WO 99/40874</b> (43) International Publication Date: 19 August 1999 (19.08.99)</p>
<p>(21) International Application Number: PCT/US99/01241 (22) International Filing Date: 22 January 1999 (22.01.99) (30) Priority Data: 09/024,571 17 February 1998 (17.02.98) US (71)(72) Applicant and Inventor: STEINKE, Thomas, A. [US/US]; 7386 Canyon Breeze Road, San Diego, CA 92126 (US). (72) Inventor: ROSS, Stephen, O.; 3745 Southridge Way, Ocean- side, CA 92056 (US). (74) Agent: ALTMAN, Daniel, E.; Knobbe, Martens, Olson &amp; Bear, LLP, 16th floor, 620 Newport Center Drive, Newport Beach, CA 92660 (US).</p>	<p>(81) Designated States: AL, AM, AT, AU, AZ, BA, BB, BG, BR, BY, CA, CH, CN, CU, CZ, DE, DK, EE, ES, FI, GB, GD, GE, GH, GM, HR, HU, ID, IL, IN, IS, JP, KE, KG, KP, KR, KZ, LC, LK, LR, LS, LT, LU, LV, MD, MG, MK, MN, MW, MX, NO, NZ, PL, PT, RO, RU, SD, SE, SG, SI, SK, SL, TJ, TM, TR, TT, UA, UG, UZ, VN, YU, ZW, ARIPO patent (GH, GM, KE, LS, MW, SD, SZ, UG, ZW), Eurasian patent (AM, AZ, BY, KG, KZ, MD, RU, TJ, TM), European patent (AT, BE, CH, CY, DE, DK, ES, FI, FR, GB, GR, IE, IT, LU, MC, NL, PT, SE), OAPI patent (BF, BJ, CF, CG, CI, CM, GA, GN, GW, ML, MR, NE, SN, TD, TG).</p> <p><b>Published</b> <i>With international search report. Before the expiration of the time limit for amending the claims and to be republished in the event of the receipt of amendments.</i></p>	

(54) Title: EXPANDABLE STENT

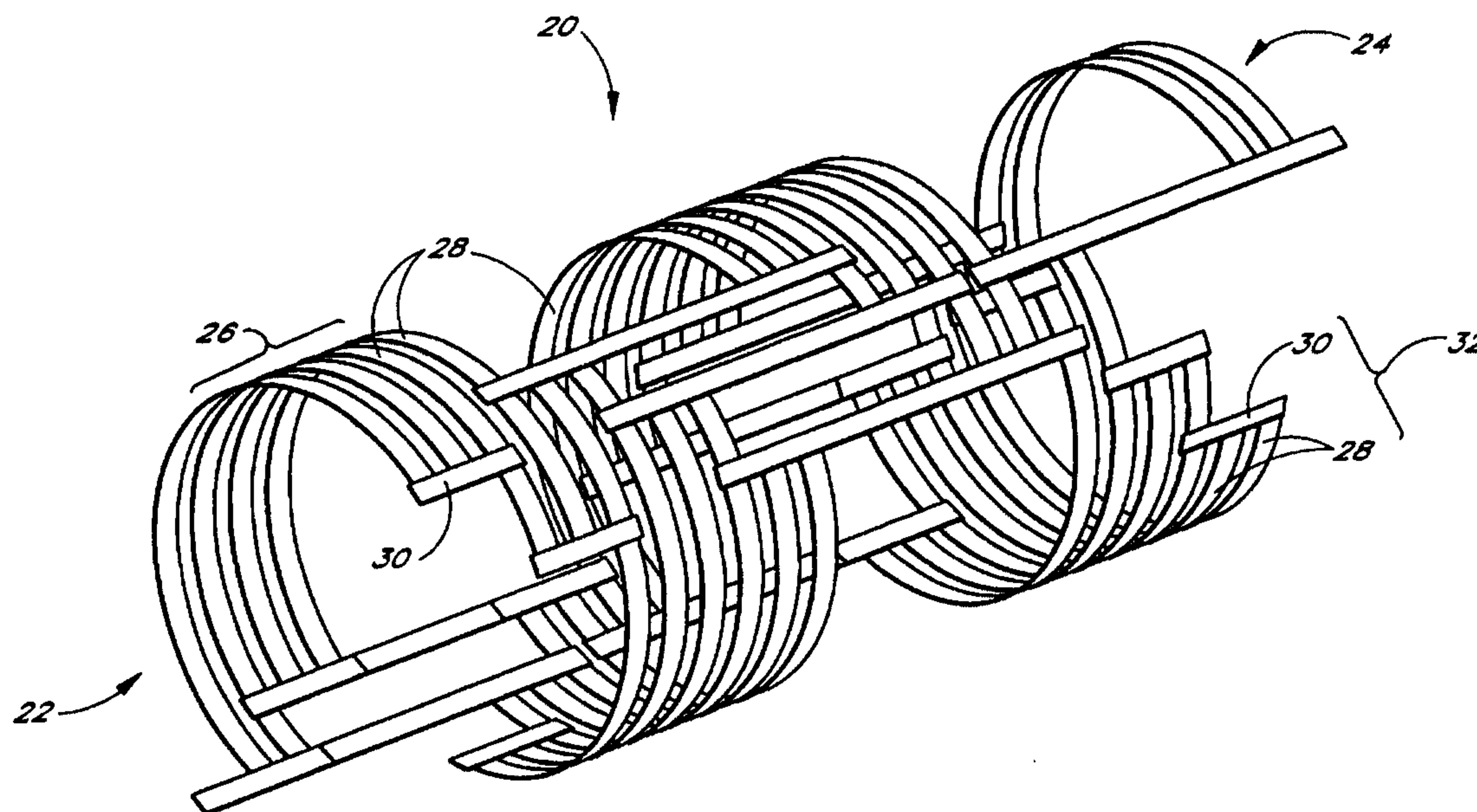
**(57) Abstract**

The present invention provides a lumen support stent (20) for use in an artery or any body lumen. The stent is formed from a plurality of ladder elements (32) having elongated ribs (28) bowed to define a circumferential arc of the tubular member and end rungs (30) affixed to the elongated ribs. The elongated ribs of adjacent ladder elements are substantially parallel to one another and slidably engaged by the end rungs of adjacent ladder elements. Sliding of the end rungs along the circumferential arc defined by the engaged ribs creates a variable circumferential distance between the end rungs of adjacent ladder elements. Consequently, the stent has a first diameter in which the circumferential distance between end rungs of adjacent ladder elements is collapsed, and a variable second diameter in which the circumferential distance between end rungs of adjacent ladder elements is expanded.

-1-

**EXPANDABLE STENT****Background of the Invention**

This invention relates to expandable medical implants for maintaining support of a body lumen.

5 An important use of stents is found in situations where part of the vessel wall or stenotic plaque blocks or occludes blood flow in the vessel. Often, a balloon catheter is utilized in a percutaneous transluminal coronary angioplasty procedure to enlarge the occluded portion of the vessel. However, the dilation of the occlusion can cause  
10 fissuring of atherosclerotic plaque and damage to the endothelium and underlying smooth muscle cell layer, potentially leading to immediate problems from flap formation or perforations in the vessel wall, as well as long-term problems with restenosis of the dilated vessel. Implantation of stents can provide support for such problems and prevent re-closure of the vessel or provide patch repair for a perforated vessel. Further, the stent may overcome the tendency of diseased vessel walls to collapse, thereby maintaining a more normal flow of blood through that vessel.

15 Examples of prior developed stents have been described by Balcon et al., "Recommendations on Stent Manufacture, Implantation and Utilization," European Heart Journal (1997), vol. 18, pages 1536-1547, and Phillips, et al., "The Stenter's Notebook," Physician's Press (1998), Birmingham, Michigan. The first stent used clinically was the self-expanding "Wallstent" which comprised a metallic mesh in the form of a Chinese fingercuff. These stents were cut from elongated tubes of wire braid and, accordingly, had the disadvantage that metal prongs from the cutting process remained at the longitudinal ends thereof. The inherent rigidity of the cobalt based alloy with a platinum core used to form the stent together with these terminal prongs made navigation of the blood vessels to the locus of the lesion difficult as well as risky from the standpoint of injury to healthy tissue along the passage  
20 to the target vessel. Furthermore, once placed, the continuous stresses from blood flow and cardiac muscle activity created significant risks of thrombosis and damage to the vessel walls adjacent to the lesion, leading to restenosis. A major disadvantage of these types of stents were that their radial expansion was associated with significant shortening in their length, resulting in unpredictable longitudinal coverage when fully deployed.

25 Among subsequent designs, some of the most popular have been the Palmaz-Schatz slotted tube stents. Originally, the Palmaz-Schatz stents consisted of slotted stainless steel tubes comprising separate segments connected with articulations. Later designs incorporated spiral articulation for improved flexibility. These stents are delivered to the affected area by means of a balloon catheter, and are then expanded to the proper size. The Palmaz-Schatz designs exhibit moderate longitudinal shortening upon expansion, with some decrease in diameter, or recoil, after deployment. Furthermore, the expanded metal mesh is associated with relatively jagged terminal prongs, which  
30 increase the risk of thrombosis and/or restenosis.

Another type of stent involves a tube formed of a single strand of tantalum wire, wound in a sinusoidal helix; these are known as the Wiktor stents. They exhibit increased flexibility compared to the Palmaz-Schatz stents; however, they do not provide sufficient scaffolding support for many applications, including calcified or bulky vascular lesions. Further, the Wiktor stents also exhibit some recoil after radial expansion.

35 Another form of metal stent is a heat expandable device using Nitinol or a tin-coated, heat expandable coil. This type of stent is delivered to the affected area on a catheter capable of receiving heated fluids. Once properly

-2-

situated, heated saline is passed through the portion of the catheter on which the stent is located, causing the stent to expand. Numerous difficulties have been encountered with this device, including difficulty in obtaining reliable expansion, and difficulties in maintaining the stent in its expanded state.

5 Self-expanding stents are problematic in that exact sizing, within 0.1 to 0.2 mm expanded diameter, is necessary to adequately reduce restenosis. However, self-expanding stents are currently available only in 0.5 mm increments. Thus, greater flexibility in expanded size is needed.

10 Stents can be deployed in a body lumen by means appropriate to their design. One such method would be to fit the collapsed stent over an inflatable element of a balloon catheter and expand the balloon to force the stent into contact with the body lumen. As the balloon is inflated, the problem material in the vessel is compressed in a direction generally perpendicular to the wall of the vessel which, consequently, dilates the vessel to facilitate blood flow therethrough. Radial expansion of the coronary artery occurs in several different dimensions and is related to the nature of the plaque. Soft, fatty plaque deposits are flattened by the balloon and hardened deposits are cracked and split to enlarge the lumen. It is desirable to have the stent radially expand in a uniform manner.

15 Alternatively, the stent may be mounted onto a catheter which holds the stent as it is delivered through the body lumen and then releases the stent and allows it to self-expand into contact with the body lumen. This deployment is effected after the stent has been introduced percutaneously, transported transluminally and positioned at a desired location by means of the catheter.

20 In summary, significant difficulties have been encountered with all prior art stents. Each has its percentage of thrombosis, restenosis and tissue in-growth, as well as various design-specific disadvantages. Thus, there is a need for an improved stent: one that has relatively smooth marginal edges, to minimize restenosis; one that is small enough and flexible enough when collapsed to permit delivery to the affected area; one that is sufficiently flexible upon deployment to conform to the shape of the affected body lumen; one that expands uniformly to a desired diameter, without change in length; one that maintains the expanded size, without significant recoil; and one that has sufficient scaffolding to provide a clear through-lumen.

25 Summary of the Invention

The present invention is a radially expandable support device, or stent, for use in an artery or any other body lumen. The stent comprises a tubular member formed from a plurality of ladder elements. Each ladder element has one or more elongated ribs bowed to define a circumferential arc of the tubular member and two or more end rungs affixed to the elongated ribs. The elongated ribs of adjacent ladder elements are substantially parallel to one another and slidably engaged by the end rungs of adjacent ladder elements. In separate embodiments of the present invention, the elongated ribs may or may not overlap with ribs of adjacent ladder elements. Sliding of the end rungs along the circumferential arc defined by the engaged ribs creates a variable circumferential distance between the end rungs of adjacent ladder elements. Consequently, the stent has a first diameter in which the circumferential distance between end rungs of adjacent ladder elements is collapsed, and a second variable diameter in which the circumferential distance between end rungs of adjacent ladder elements is expanded.

35

The maximum circumference (and diameter) of the expandable stent is defined by the number of ladder elements which comprise a series, whereas the axial length of the stent is defined by the number of series employed. The stent further comprises longitudinal support elements, which couple the end rungs from adjacent series of ladder elements, thereby fixing the coupled series of ladder elements at a constant longitudinal distance from one another.

5 The longitudinal support elements and end rungs may be oriented either substantially parallel to the longitudinal axis of the stent or diagonally, at an angle to the longitudinal axis. In one embodiment, a longitudinal backbone runs the entire axial length of the stent.

Finally, the expandable stent further comprises a plurality of locking means for maintaining the stent in its expanded diameter. The locking means permit adjacent end rungs to slide circumferentially apart, thereby expanding

10 the diameter of the tubular member. However, the locking means prevent the end rungs from sliding back toward a more collapsed state, thereby minimizing stent recoil after deployment.

#### Brief Description of the Drawings

Figure 1 is a perspective view of an embodiment of the expandable stent in accordance with the present invention

15 Figure 2 is a plan view of an expandable stent in accordance with the present invention, illustrating a series of overlapping ladder elements.

Figure 3 is a plan view of an expandable stent in accordance with the present invention, showing three series of three ladder elements each.

20 Figure 4 is a perspective view of an embodiment of the present invention showing a longitudinal backbone spanning the entire length of the tubular member.

Figure 5 is a plan view of another preferred embodiment of the present invention having diagonal end rungs and longitudinal support elements.

Figure 6 is a perspective view of the embodiment illustrated in Figure 5.

25 Figure 7 is an enlarged detail view of a portion of an elongated rib slidably engaged by the end rung of an adjacent ladder element.

Figure 8 is an enlarged detail view of a portion of an elongated rib slidably engaged by the end rung of an adjacent ladder element.

Figure 9 is an enlarged detail view showing an embodiment of a one-way locking means.

Figure 10 is an enlarged detail view showing another embodiment of a one-way locking means.

30 Figure 11 is an enlarged detail view showing a preferred embodiment of a one-way locking means.

Figure 12 is an enlarged detail view showing another embodiment of a one-way locking means.

Figure 13 is an enlarged detail view showing an embodiment of a two-way locking means.

Figure 14 is an enlarged detail view showing another embodiment of a two-way locking means.

Figure 15 is an enlarged detail view showing another embodiment of a two-way locking means.

35 Figure 16 is an enlarged detail view showing another embodiment of a two-way locking means.

Figure 17 is an enlarged detail view showing another embodiment of a one-way locking means.

-4-

Figure 18 is an enlarged detail view showing another embodiment of a two-way locking means.  
 Figure 19 is an enlarged detail view showing another embodiment of a two-way locking means.  
 Figure 20 is an enlarged detail view showing another embodiment of a one-way locking means.  
 Figure 21 is an enlarged detail view showing another embodiment of a one-way locking means.  
 5 Figure 22 is an enlarged detail view showing another embodiment of the locking means.  
 Figure 23 is an enlarged detail view showing another embodiment of a two-way locking means.  
 Figure 24 is an enlarged detail view showing another embodiment of a two-way locking means.  
 Figure 25 is an enlarged detail view showing another embodiment of a one-way locking means.  
 Figure 26 is an enlarged detail view showing another embodiment of a one-way locking means.  
 10 Figure 27 is an enlarged detail view showing another embodiment of a one-way locking means.  
 Figure 28 is an enlarged detail view showing another preferred embodiment of a one-way locking means.  
 Figure 29 is an enlarged detail view showing another preferred embodiment of a one-way locking means.

#### Detailed Description of the Preferred Embodiment

Referring to Figure 1, there is shown a perspective view of an embodiment of the expandable stent in  
 15 accordance with the present invention. The tubular member 20 has a proximal end 22 and a distal end 24. The  
 tubular member 20 has ribbed walls 26 comprising elongated ribs 28, oriented circumferentially, and end rungs 30,  
 oriented in the longitudinal axis. Elongated ribs 28 are substantially parallel to one another and perpendicular to the  
 longitudinal axis of the tubular member. The ribs are attached to end rungs 30 to form rectangular ladder elements  
 32, which are the basic unit of construction.

20 Referring to Figure 2, a plan view of a stent in accordance with the present invention shows a series 34  
 of overlapping ladder elements 32. The elongated ribs 28 from one ladder element are slidably engaged by the end  
 rungs 30 of adjacent ladder elements, such that the ladder elements can slide together, as shown in Figure 2A,  
 yielding a collapsed length ( $L_c$ ), or the ladder elements can slide apart, as shown in Figure 2B, yielding an expanded  
 length ( $L_e$ ). The number of ladder elements which comprise a series 34 can vary within the range of about 2 to 8,  
 25 preferably between 3 to 5 ladder elements per series. Thus, the stent can be manufactured having a variety of  
 expansion ratios.

As the number of overlapping ladder elements increases, the maximum  $L_e$  also increases as does the  
 expansion ratio ( $L_e:L_c$ ). The circumference of the tubular member is defined when the series 34 is rolled to form a  
 tubular member. It is important to note that the expanded length ( $L_e$ ), and consequently, the expanded diameter and  
 30 circumference of any given stent made in accordance with the present invention, may vary depending on the amount  
 of sliding which is induced during deployment. Thus, the tubular member of the stent may have a first, collapsed  
 diameter (defined by a collapsed distance between adjacent end rungs), and a second, expanded diameter (defined  
 by an increased distance between adjacent end rungs), wherein the second diameter is variable and determined by  
 the desired expanded internal diameter of the body passageway.

35 Whereas the number of ladder elements per series defines the maximum circumference of the tubular  
 member, and thereby the diameter of the tubular member, the total axial length of the tubular member is determined

by the number of series which are joined longitudinally to form the stent. Referring to Figure 3, a plan view of a stent in accordance with the present invention illustrates three series of three ladder elements each. Each series is coupled with the adjacent series by a longitudinal support element 36, which is attached to the end rungs 30 from adjacent series. The longitudinal support elements 36, not only serve as coupling means for joining one series to the next, they also fix the longitudinal distance between adjacent series and provide axial strength, which prevents shortening or lengthening of the expanding stent during deployment.

Referring to Figure 4, there is illustrated a perspective view of an embodiment of the present invention showing a tubular member 20 having a proximal 22 and distal 24 end. The elongated ribs 28 are bowed to form a circumferential arc. The ribs are attached to end rungs 30. In this embodiment, a longitudinal backbone 38, spanning the entire length of the tubular member connects all of the end rungs that lie along a straight line in the longitudinal axis. The backbone functions just like the individual longitudinal support elements 36, by coupling adjacent series to one another, and providing axial strength. However, while employment of backbone provides optimal axial strength, preventing changes in length during deployment, an embodiment of the stent having a backbone also reduces the flexibility of the prosthesis in conforming to bends in the target vessel. Thus, while stents may incorporate a longitudinal backbone in accordance with the present invention for use in straight segments of target vessels, it is important to recognize that the backbones are an optional feature, and that flexible stents in accordance with the present invention, having only the shorter longitudinal support elements (illustrated in Figure 3) or diagonally disposed end rungs and longitudinal support elements provide another preferred embodiment (see below; Figure 5 and 6).

Referring to Figure 5, there is shown a plan view of another preferred embodiment of the present invention. The tubular member is again constructed from separate series 34 of ladder elements 32, each comprising elongated ribs 28 and end rungs 30, the rungs from one series being connected to end rungs on the adjacent series by longitudinal support elements 36. However, whereas the end rungs 30 and longitudinal support elements 36 run parallel to the longitudinal axis of the tubular member in Figure 3, they may alternatively, run at an angle diagonal to the longitudinal axis of the tubular member, as illustrated in Figure 5. Thus, the resulting ladder element assumes the shape of a parallelogram, instead of a rectangle. The angle at which the end rungs and longitudinal support elements deviate from the longitudinal axis may vary between 0 and 60 degrees. More preferably the angle will be in the range of about 15 and 60 degrees. Most preferably, the angle varies between 15 and 45 degrees.

A perspective view of this embodiment is illustrated in Figure 6, having diagonal end rungs 30 and longitudinal support elements 36. The elongated ribs 28 in this embodiments are substantially parallel to one another and perpendicularly disposed to the longitudinal axis. The end rungs 30, however, do not run parallel to the longitudinal axis in this stent. Instead, the end rungs 30 are diagonally aligned at a angle to the longitudinal axis. Any longitudinal support elements employed in constructing a stent in accordance with this preferred embodiment of the present invention, are also diagonally aligned at the same angle to the longitudinal axis as the end rungs.

It is important to appreciate the many layers of design flexibility embodied by the present invention. First, referring back to Figures 2A and 2B, stent diameter may be varied readily during manufacture by varying the number

of ladder elements 32 per series 34. The collapsed ( $L_c$ ) and expanded ( $L_e$ ) circumferential distance, and therefore tubular diameter, is defined by the distance between the first and last end rung in a series. Specifically, expandable stents in accordance with the present invention may range in diameter from about 0.5-5.0 mm in the collapsed state to about 1.0-200 mm in the expanded state. More preferably the diameters may range from about 0.7-1.8 mm collapsed to about 2.0-8.0 mm expanded.

Next, referring back to Figures 3 and 4, the total axial length of the stent may be varied by employing different numbers of series 34, connected to one another in the longitudinal axis by longitudinal support elements 36 and/or longitudinal backbones. Differences in the axial length of the end rungs 30 will also vary the total axial length of the stent. Generally, for traditional stent applications, at least two series will be employed; however, it is conceived that collar stents in accordance with the present invention, comprising a single series of ladder elements, may be used to secure a polymeric sleeve or graft against a vessel wall at proximal and distal ends flanking an aneurysm. Specifically, stents in accordance with the present invention may range in total length from about 1.0-200 mm. More preferably, the lengths may range from about 4.0-40 mm, and most preferably, from about 16-24 mm.

Another parameter of design flexibility involves delivery and implanted flexibility. Delivery flexibility allows curving of the stent on the catheter to facilitate delivery to the target site. Implant flexibility allows for curving of the stent to conform to curved vessels and lumen. As stent flexibility is increased, axial strength and rigidity are compromised. The manufacturer of stents in accordance with the present invention has numerous options for selecting the proper combination of flexibility and axial strength for a given clinical application. One option for varying flexibility involves adjusting the number of longitudinal support elements 36. For instance, if a series 34 of ladder elements 32 is not connected to its adjacent series at all, the resulting segmented stent will afford maximal flexibility. On the other hand, if longitudinal support elements 36 connect each complementary end rung 30 in adjacent series, very little flexibility is fostered. But, the first, more flexible embodiment, will be more susceptible to axial compression, while the second, less flexible embodiment will exhibit much enhanced axial strength. As discussed above, the inclusion of a longitudinal backbone 38 would greatly increase axial strength and concomitantly, reduce delivery and implantation flexibility. The full range of engineered flexibility and axial strength are encompassed within the spirit of the present invention.

As discussed above, referring to Figures 5 and 6, another option through which the manufacturer may vary the flexibility/axial strength ratio would be to employ end rungs 30 and longitudinal support elements 36 which run diagonal to the longitudinal axis of the tubular member. Indeed, stent flexibility can be varied by incorporating different numbers of diagonal longitudinal support elements 36 and by varying the angle of deflection. The smaller the angle of deflection from the longitudinal axis, the less flexibility (and the greater the axial strength). Thus, stent designs in accordance with the present invention may be optimized for particular clinical applications.

Referring to Figure 7, there is shown a detail view of one embodiment of an elongated rib 28c slidably engaged in an end rung 30. The end rung 30 is formed from two identical rung leaves, 40 and 42, which are fastened to the elongated ribs 28a and 28b from the same ladder element, in a sandwich-like manner, thereby creating an open passage through which the elongated rib 28c from an adjacent ladder element may slide. Many



embodiments for the slidable engagement means are envisioned. Paired parallel slots formed in the end rung may be used to engage the elongated ribs, wherein the ribs pass through one slot and return through the other in a weave-like fashion. Alternatively, the end rung material between the paired slots may be displaced vertically from the surface of the end rung during manufacture, thereby creating a passage through which a rib may slide without bending upward and downward relative to the surface of the end rung. Similarly, a separate strap or wire guide may be affixed on the end rung to create a channel through which the engaged rib may slide. Any other slidable articulations known in the art are also conceived as potential engagement means.

In addition to the variety of configurations for the slidable engagement means, the locations of these slidable engagement means on the ladder elements may also vary. For example, Figure 8, shows an elongated rib 28c slidably engaged in an end rung 30, however, instead of the engagement means being located between ribs in one ladder element (as illustrated in Figure 7), the engagement means shown in Figure 8 is located at a free end of an end rung 30. The slidably engaged elongated rib 28c passes through a passage created by folding the end rung 30 about the fixed rib 28a. The resultant upper 40 and lower 42 leaves of the end rung 30 define the passage. Thus, it is envisioned that different embodiments of the stent according to the present invention, will employ engagement means located either at the junctions between ribs and end rungs on a given ladder element, between ribs (as shown in Figure 7), at terminal end rungs which are only attached to one rib (as shown in Figure 8), or at terminal end rungs which are attached to two or more ribs, but which extend beyond that axial distance of the ladder element defined between its ribs.

Referring to Figures 9-29, there are illustrated many different embodiments of locking means. For clarity, all of the locking means have been illustrated on the least cluttered locations for engagement means, the terminal end rungs 30 attached to a single fixed rib 28a. However, it is important to note that these locking means may be incorporated within slidable engagement means at any of the above discussed locations. Figure 9 shows one embodiment of the locking means having stops 44 on the slidably engaged rib 28c. The stops 44 can pass through the engagement means in only one direction (expanding the stent). In this embodiment, the stops 44 are in the form of tabs which protrude at an angle upward off the surface of the rib 28c. These tab stops 44 are depressed when passing through the engagement means and then spring out, thereby preventing the slidably engaged rib 28c from moving relative to the end rung 30, back toward a more collapsed configuration.

Referring to Figure 10, another embodiment of the locking means is shown, wherein the slidably engaged rib 28c is notched on its edges in such a manner as to permit movement in only one direction relative to the end rung 30. In this embodiment, the notched edges of the engaged rib 28c form the stops 44. Again, the stops are depressed as they pass through the engagement means and spring out laterally to prevent recoil.

Referring to Figure 11, there is illustrated a preferred locking means in which a sprung tab 46 is attached to the engagement means and the slidably engaged rib 28c is modified to have a plurality of holes or notches 48 adapted to engage the sprung tab 46. The angle at which the tab 46 engages the holes 48 permits only one-way sliding. Referring to Figure 12, there is shown another variation of the locking means illustrated in Figure 10. Notched stops 44 in the slidably engaged rib 28c permit only one-way sliding.

Referring to Figures 13-16, there are shown a variety of locking means that operate by resisting sliding in either direction. Effectiveness of these embodiments is based on deployment using high pressure balloon catheters. Thus, the collapsed stent is deployed by inflating the balloon, which exerts sufficient radial pressure to overcome the resisting force of the locking means. For example, Figure 13 shows a friction-based locking means. 5 The stop 44 is created by a rough surface on the sliding rib 28c. Once forcibly deployed using the balloon catheter, the resistance to sliding due to friction would be sufficient to prevent recoil, absent application of a radially inward force greater than or equal to the radially outward force exerted by the balloon during expansion. Figure 14-16 illustrate other embodiments of locking means which will resist sliding in either direction. The locking means shown in Figures 14 and 15 have a plurality of raised convex male stops 48 on the surface of the sliding rib 28c and a 10 complementary concave female catch 46. As the rib 28c slides, the male stops 48 are engaged by the female catch 46, thereby resisting further sliding. Referring to Figure 16 there is shown another variation, having a knob catch 46 attached to the end rung. The sliding rib 28c is modified to have a central channel, through which the knob catch passes. The channel has a repeating pattern of stops 48 cut into the channel, such that as the rib slides, the knob catch 46 lodges in the stops 48, thereby resisting further sliding.

15 Referring to Figure 17, there is illustrated another variation in the notch 48 and stop 46 locking means, however, in this embodiment, the notches are cut laterally into a central channel in the sliding rib 28c, whereas the stop 46 is engineered to have depressible lateral catches which are adapted to permit one-way sliding of the rib 28c relative to the end rung.

Figures 18 and 19 illustrate additional embodiments of two-way locking means, that resist sliding in either 20 direction. The locking means shown in Figure 18 have female dimples 48 in the lateral edges of the sliding rib 28c and male catches 46 within the engagement means. The male catches exhibit sufficient flexibility to flex outward during sliding, but then snapping into the dimples 48 as they enter the engagement means. The embodiment shown in Figure 19 has female dimples 48 disposed laterally from a central channel and a male knob catch 46.

Another embodiment of a one-way locking means is shown in Figure 20. The rib 28c has a central channel 25 lined at regular intervals with angled stops 48 which are depressed as they pass through the engagement means 46, and then spring laterally outward to prevent recoil.

The locking means shown in Figure 21 employs raised stops 48 on the sliding rib 28c. The stops 48 are angled to permit one-way sliding through a catch 46 housed in the engagement means. Likewise, the embodiment illustrated in Figure 22 has raised stops 48, which are square-shaped and a sprung tab 46 having a complementary 30 square-shaped hole adapted for receiving the raised stops 48. The sprung tab may be shaped to allow either one-way or two-way resistance.

The embodiment in Figure 23 involves modification of both the sliding rib 28c as well as the fixed rib 28a. The sliding rib 28c has a deflectable tab stop 48, which interacts with regularly spaced dimpled catches on the lateral edge of the adjacent, fixed rib 28a. Figure 24 shows another two-way locking means, wherein the catch 46 35 on the engagement means interacts with notched stops 48 along the outer lateral edge of the sliding rib 28c.

Figures 25-29 illustrate additional embodiments of one-way locking means. In Figures 25-27, the arresting mechanism involves the interaction of sprung tabs or stops 48 formed on the slidably engaged rib 28c and a catch or receiving means 46 formed by the engagement means on the end rung. Figures 28 and 29, are different in that the stops 48 are staggered on the surface of the sliding rib, in order to provide less recoil.

5 Typically, the elongated ribs, end rungs and longitudinal support elements would be made of the same material. Metals, such as stainless steel, tantalum, titanium, or a shape memory metal such as Nitinol, may be used. The stents embodied by the present invention may also be partially fabricated from or coated with a radiopaque metal such as tantalum or gold to provide a fluoroscopic indication of the stent position within the lumen. Preferably, the proximal and distal ends would incorporate the radiopaque marker material. Alternatively, the  
10 longitudinal support elements would preferably be made of radiopaque material such as gold, platinum, or tantalum.

It should be understood that all stent edges are preferably smooth and rounded to prevent thrombogenic processes and reduce the stimulation of intimal smooth muscle cell proliferation and potential restenosis. Furthermore, the stent material may be coated with materials which either reduce acute thrombosis, improve long-term blood vessel patency, or address non-vascular issues. Coating materials that may be utilized to reduce acute  
15 thrombosis include: parylene; anticoagulants, such as heparin, hirudin, or warfarin; antiplatelet agents, such as ticlopidine, dipyridamole, or GPIIb/IIIa receptor blockers; thromboxane inhibitors; serotonin antagonists; prostanoids; calcium channel blockers; modulators of cell proliferation and migration (e.g. PDGF antagonists, ACE inhibitors, angiopeptin, enoxaparin, colchicine) and inflammation (steroids, non-steroidal anti-inflammatory drugs). Coating materials which may be used to improve long-term (longer than 48 hours) blood vessel patency include: angiogenic  
20 drugs such as, Vascular Endothelial Growth Factor (VEGF), adenovirus, enzymes, sterol, hydroxylase, and antisense technology; drugs which provide protection on consequences of ischemia; lipid lowering agents, such as fish oils, HMG, Co-A reductase inhibitors; and others. Finally, drugs that address non-vascular issues such as ibutilide fumarate (fibrillation/flutter), adenylyclase (contractility), and others, may be applied as stent coatings.

In one embodiment, the expandable stent of the present invention is designed for intraluminal deployment  
25 by a balloon catheter in a conventional manner. The tubular body of the stent is first positioned to surround a portion of an inflatable balloon catheter. The stent, with the balloon catheter inside is configured at a first, collapsed diameter, wherein the circumferential distance between end rungs from adjacent ladder elements is collapsed. The stent and the inflatable balloon is percutaneously introduced into a body lumen, following a previously positioned guidewire in an over-the-wire angioplasty catheter system, and tracked by a fluoroscope, until the balloon  
30 portion and associated stent are positioned within the body passageway at the point where the stent is to be placed. Thereafter, the balloon is inflated and the stent is expanded by the balloon portion from the collapsed diameter to an expanded diameter. After the stent has been expanded to the desired final expanded diameter, the balloon is deflated and the catheter is withdrawn, leaving the stent in place.

The expanded diameter is variable and determined by the desired expanded internal diameter of the body  
35 passageway. Accordingly, the controlled expansion of the stent is not likely to cause a rupture of the body passageway. Furthermore, the stent will resist recoil because the locking means resist sliding of the elongated ribs

-10-

within the engagement means on the end rungs. Thus, the expanded intraluminal stent will continue to exert radial pressure outward against the wall of the body passageway and will therefore, not migrate away from the desired location.

5 A self-expanding stent in accordance with another embodiment of the present invention may be deployed without the use of an inflatable balloon. Instead, the stent may be maintained in its collapsed state on a catheter by a physical restraint, such as an outer sheath or other means. The catheter and stent are advanced as above to the target site, tracking the stent location by fluoroscopy (focusing on the radiopaque elements of the stent). Once at the target site, the stent collapsed around the underlying catheter may be deployed by removing the restraint. For instance, the restraining sheath may be withdrawn, thereby freeing the stent of the physical restraint.  
10 Alternatively, the sheath may remain stationary while the collapsed stent and catheter are pushed through the end of the sheath. Regardless of the means of removing the restraint, the stent is then permitted to expand naturally under the influence of its inherent spring force to its second, expanded diameter, bearing against the inner walls of the target passageway.

15 While a number of preferred embodiments of the invention and variations thereof have been described in detail, other modifications and methods of using and medical applications for the same will be apparent to those of skill in the art. Accordingly, it should be understood that various applications, modifications, and substitutions may be made of equivalents without departing from the spirit of the invention or the scope of the claims.

WO 99/40874

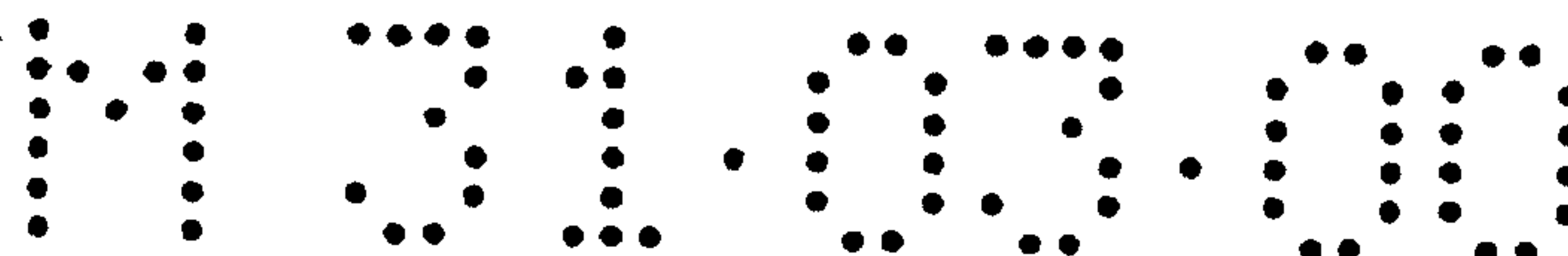

PCT/US99/01241

-11-

**WHAT IS CLAIMED IS:**

1. An expandable intraluminal stent, wherein the improvement comprises:
  - a tubular member (22) comprising a series of discrete slidably engaged ladder elements (32), each ladder element comprising one or more radially disposed elongated ribs (28), each having two ends, and two end rungs (30), wherein an end rung is affixed to each end of each elongated rib;
    - wherein an elongated rib from a first ladder element is slidably engaged by a portion of an end rung from a second ladder element, such that radial sliding of the ladder elements creates a variable radial distance between the end rungs of the first and second ladder elements;
    - said tubular member having a first diameter in which the distance between end rungs of the first and second ladder elements is collapsed; and
    - said tubular member having a second diameter, in which the distance between end rungs of the first and second ladder elements is expanded.
2. The expandable stent of claim 1, wherein the elongated ribs of adjacent ladder elements overlap in a symmetrical repeating pattern, such that one rib from the first ladder element is disposed between the ribs from the second, adjacent ladder element.
3. The expandable stent of claim 1, wherein said elongated ribs and said end rungs, which comprise each ladder element, define a rectangular shape, such that the elongated ribs are circumferentially disposed and substantially perpendicular to a longitudinal axis of the tubular member, whereas the end rungs are substantially parallel to one another in the longitudinal axis and substantially perpendicular to the elongated ribs.
4. The expandable stent of claim 1, wherein each ladder element defines a parallelogram shape, such that the end rungs are substantially parallel to one another and aligned diagonally at an angle to a longitudinal axis of the tubular member.
5. The expandable stent of claim 4, wherein the angle may vary from about 0 degrees to about 60 degrees.
6. The expandable stent of claim 1, wherein a maximum circumference of the tubular member is defined by a series of at least three ladder elements.
7. The expandable stent of claim 1, wherein a maximum circumference of the tubular member is defined by a series of at least five ladder elements.
8. The expandable stent of claim 6, wherein an axial length of the tubular member is defined by at least two series of ladder elements.
9. The expandable stent of claim 8, further comprising one or more longitudinal support elements, each of which couples the end rungs in at least two adjacent series of ladder elements, thereby fixing the coupled series of ladder elements at a constant longitudinal distance from one another.
10. The expandable stent of claim 9, wherein said longitudinal support element runs substantially parallel to the coupled end rungs and the longitudinal axis of the tubular member.
11. The expandable stent of claim 9, wherein said longitudinal support element runs substantially parallel to the end rungs, being aligned diagonally at an angle to the longitudinal axis of the tubular member.
12. The expandable stent of claim 1, further comprising a longitudinal backbone which runs substantially parallel to the longitudinal axis of said tubular member and spans the entire axial length of said tubular member.
13. The expandable stent of claim 1, further comprising a longitudinal backbone which runs at an angle to the longitudinal axis of the tubular member and spans the entire axial length of said tubular member.
14. The expandable stent of claim 1, further comprising a plurality of locking means for maintaining the tubular member in its second, expanded diameter.
15. The expandable stent of claim 14, wherein said locking means permit adjacent end rungs to slide circumferentially apart, thereby expanding the diameter of the tubular member, but wherein said locking means prevent the end rungs from sliding back toward a more collapsed state, thereby minimizing stent recoil after deployment.
16. The expandable stent of claim 1, wherein said tubular member expands from the first, collapsed diameter to the second, expanded diameter upon application from inside the tubular member of a radially outwardly extending force.

WO 99/40874

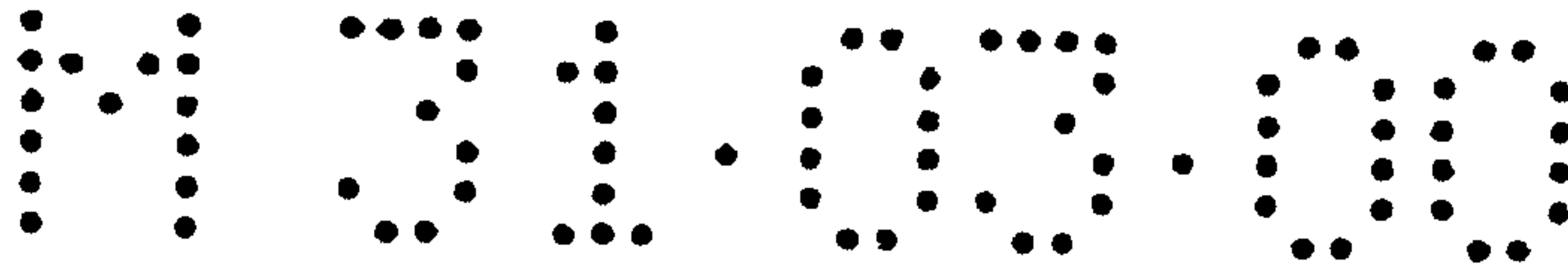

PCT/US99/01241

-12-

17. The expandable stent of claim 1, wherein said tubular member is maintained under a restraint, in the first, collapsed diameter and upon removal of said restraint, the tubular member self-expands to the second, expanded diameter.

5 18. The expandable stent of claim 1, wherein any corners and edges are rounded, such that said corners and edges present a substantially smooth intraluminal profile.

19. The expandable stent of claim 1, wherein the ladder elements are treated with a coating agent which reduces acute thrombosis, improves long-term blood vessel patency, or addresses non-vascular issues.

10 20. The expandable stent of claim 19, wherein the coating agent is selected from the group consisting of parylene, heparin, hirudin, warfarin, ticlopidine, dipyridamole, GPIIb/IIIa receptor blockers, thromboxane inhibitors, serotonin antagonists, prostanoids, calcium channel blockers, PDGF antagonists, ACE inhibitors, angiopeptin, enoxaparin, colchicine, steroids, non-steroidal anti-inflammatory drugs, VEGF, adenovirus, enzymes, sterol, hydroxylase, antisense sequences, fish oils, HMG, Co-A reductase inhibitors, ibutilide fumarate, and adenylyclase.

21. The expandable stent of claim 1, wherein at least a portion of the stent is radiopaque.

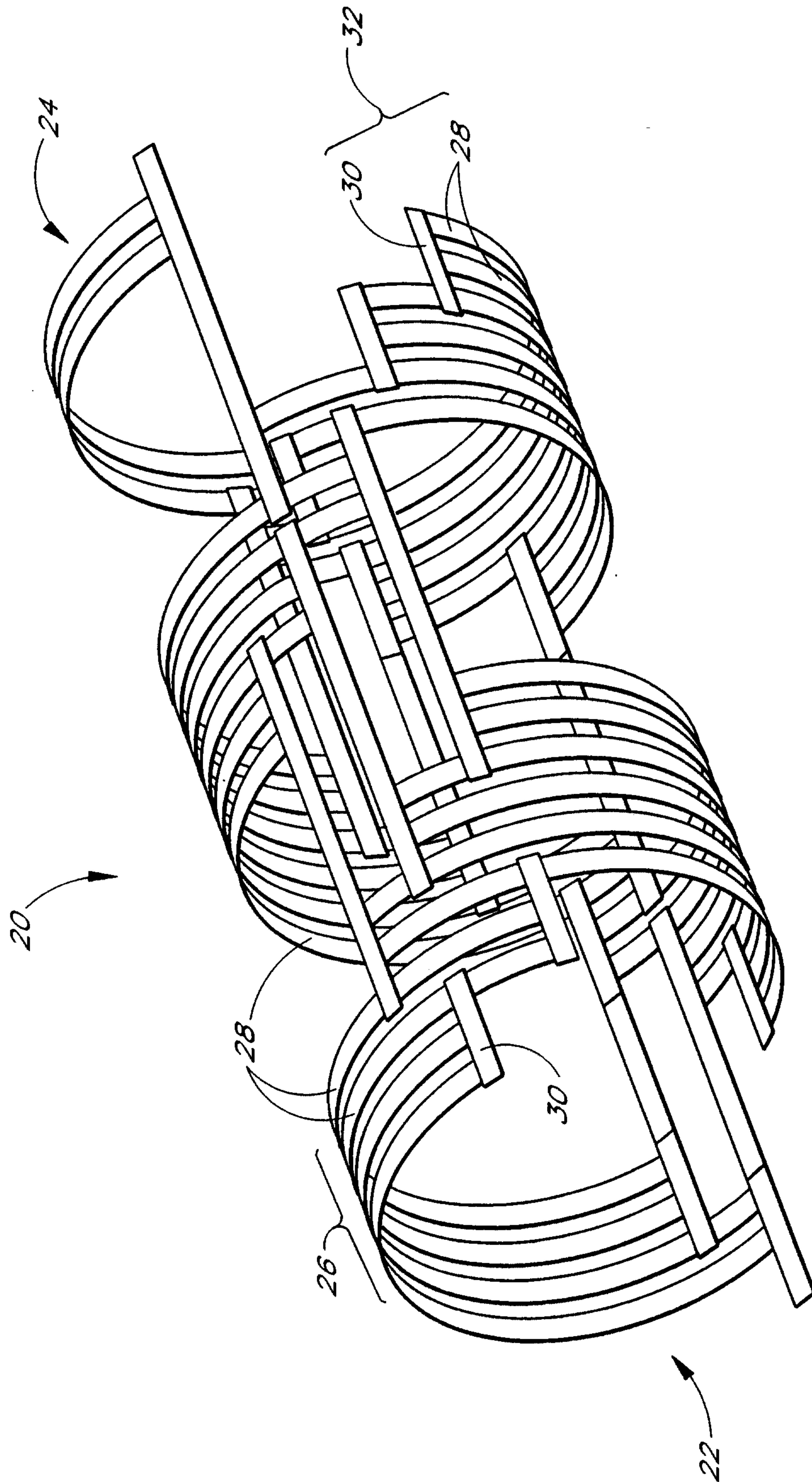

FIG. 1

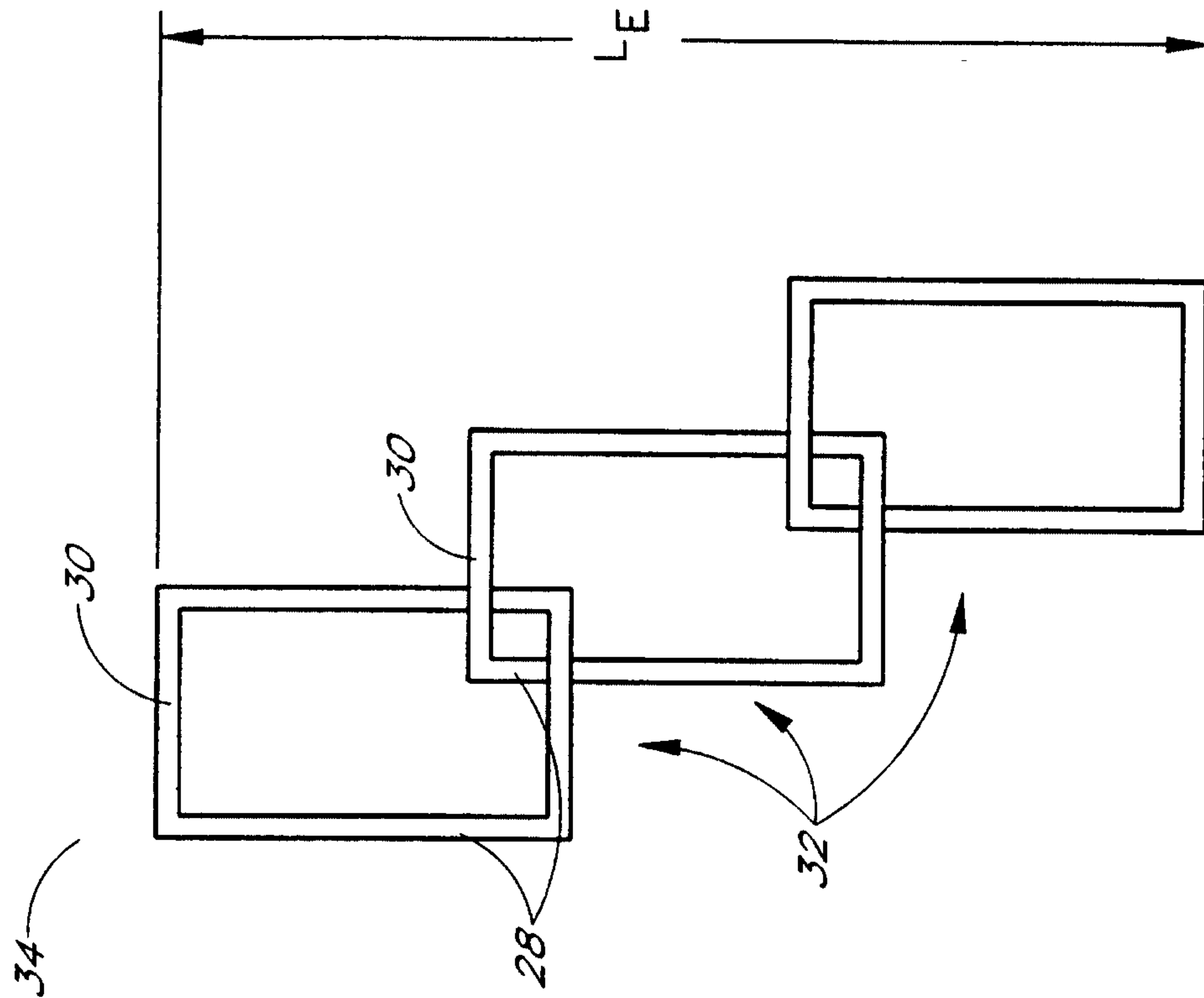

FIG. 2A

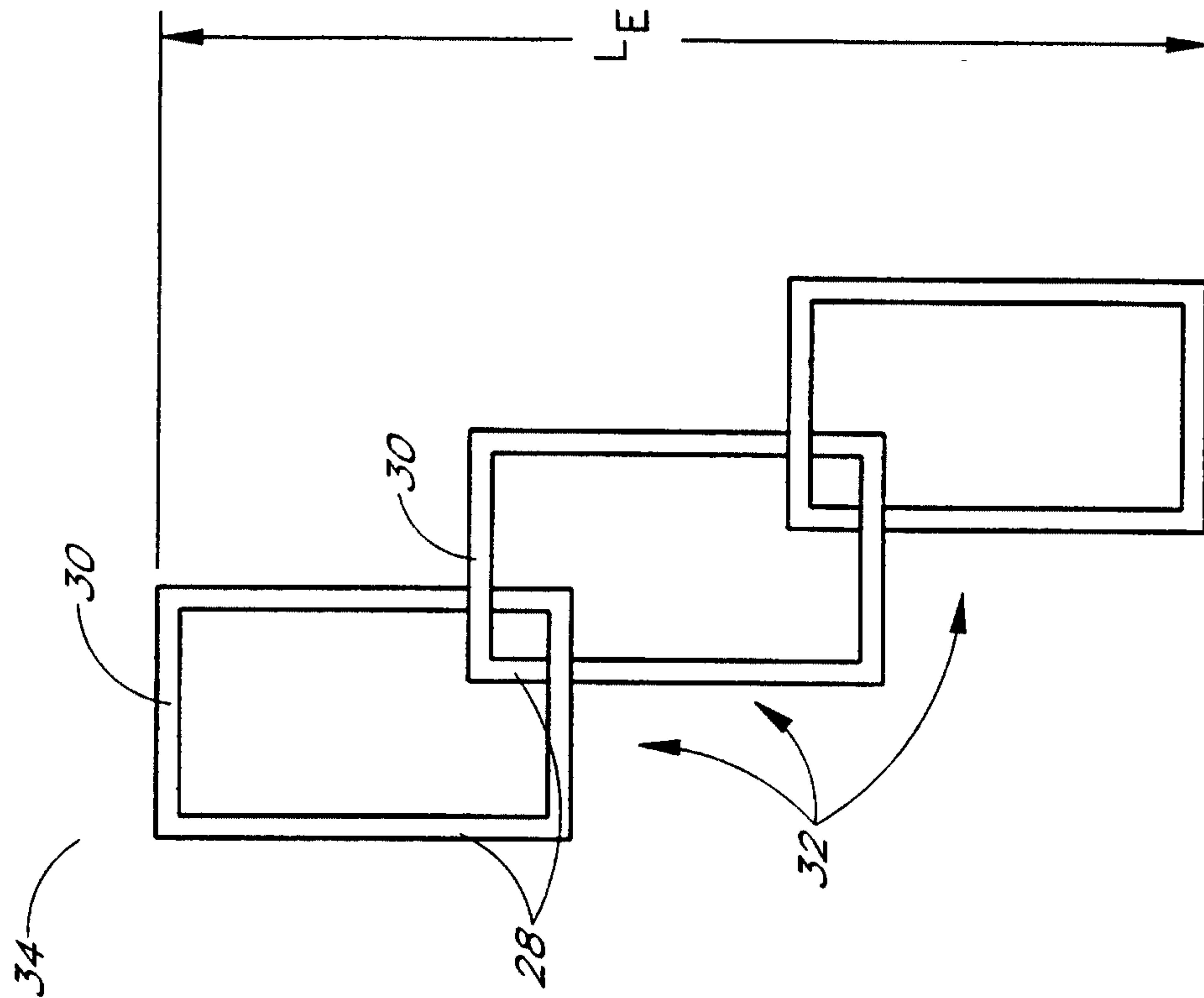

FIG. 2B



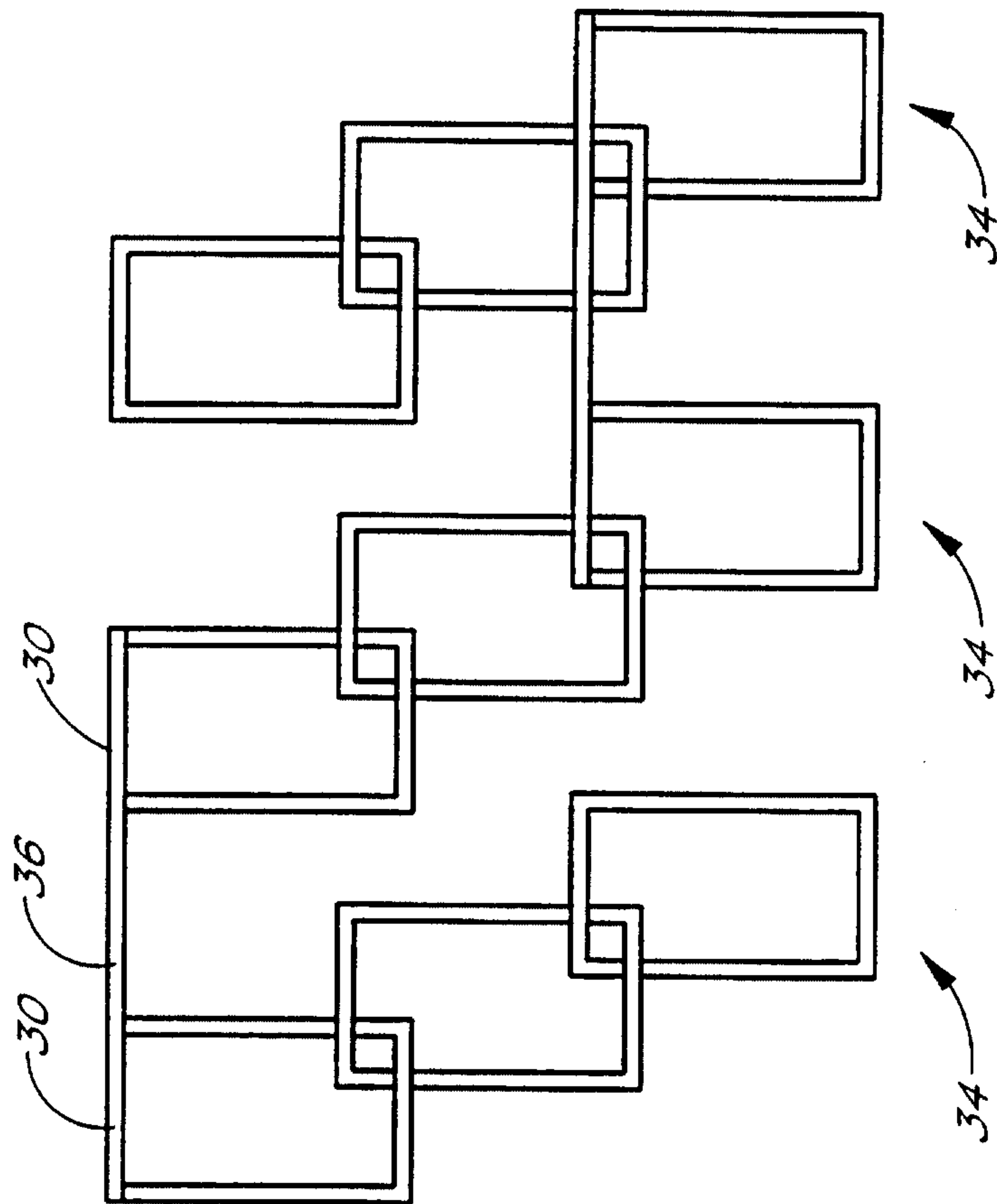

FIG. 3

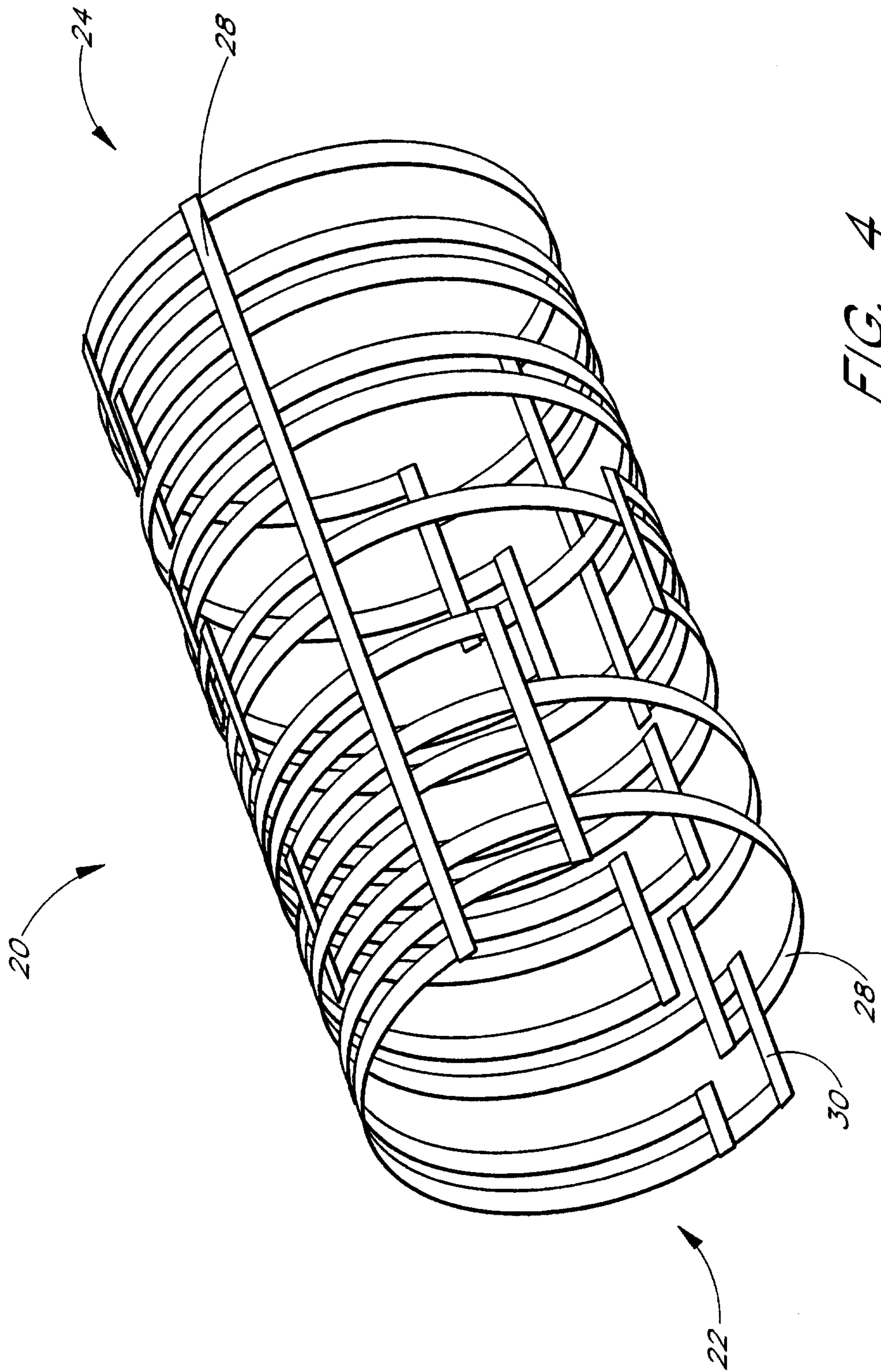

FIG. 4

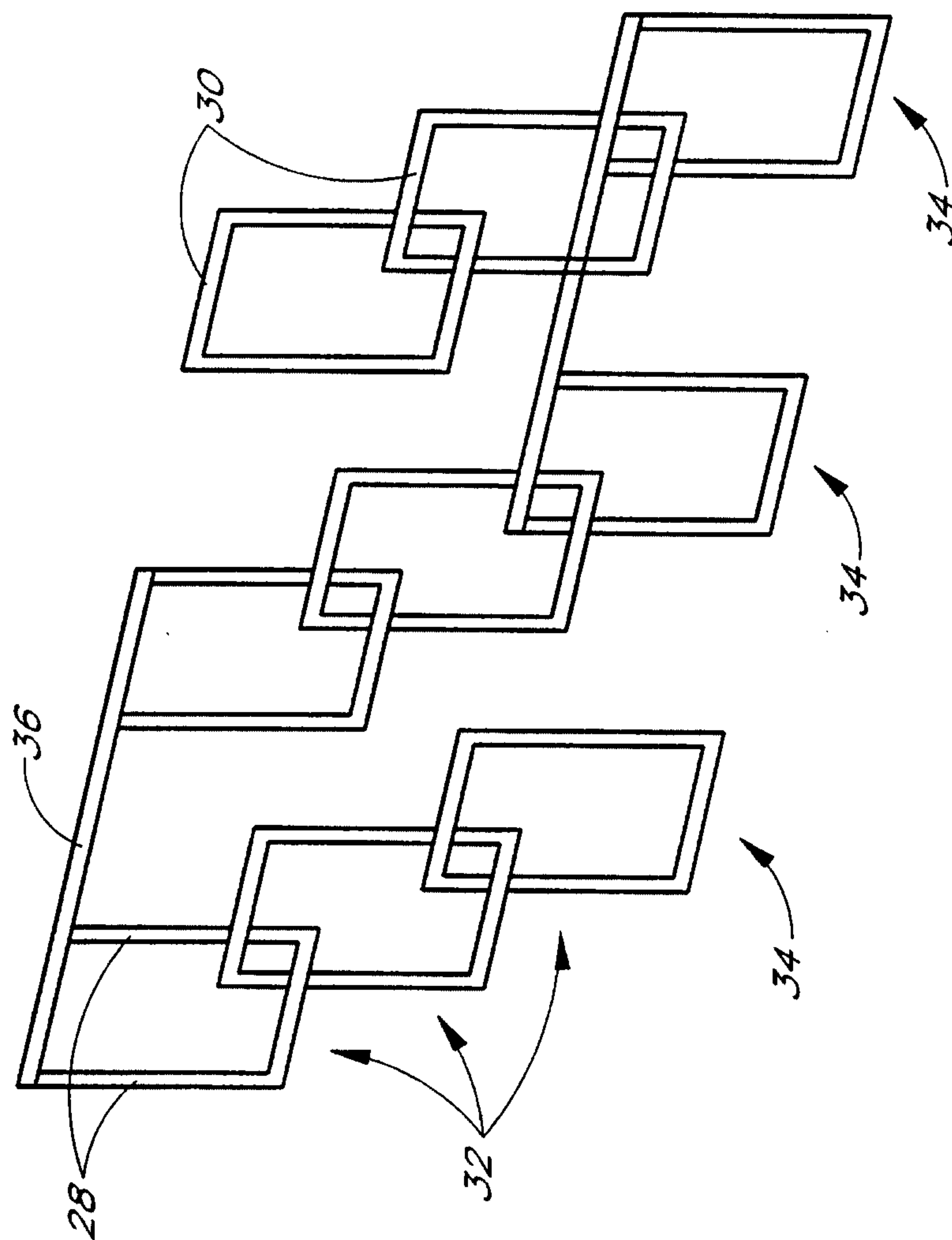

FIG. 5

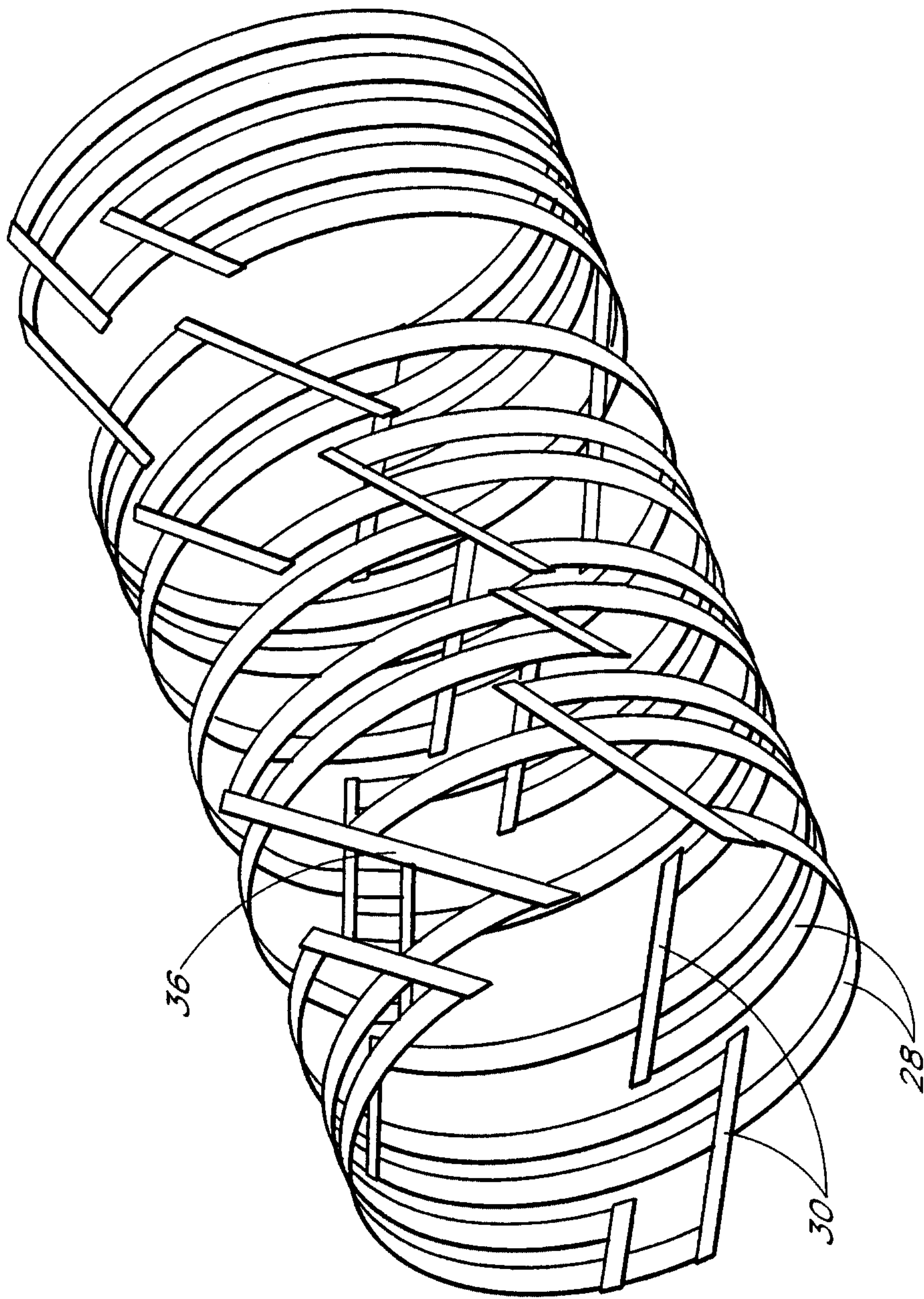

FIG. 6

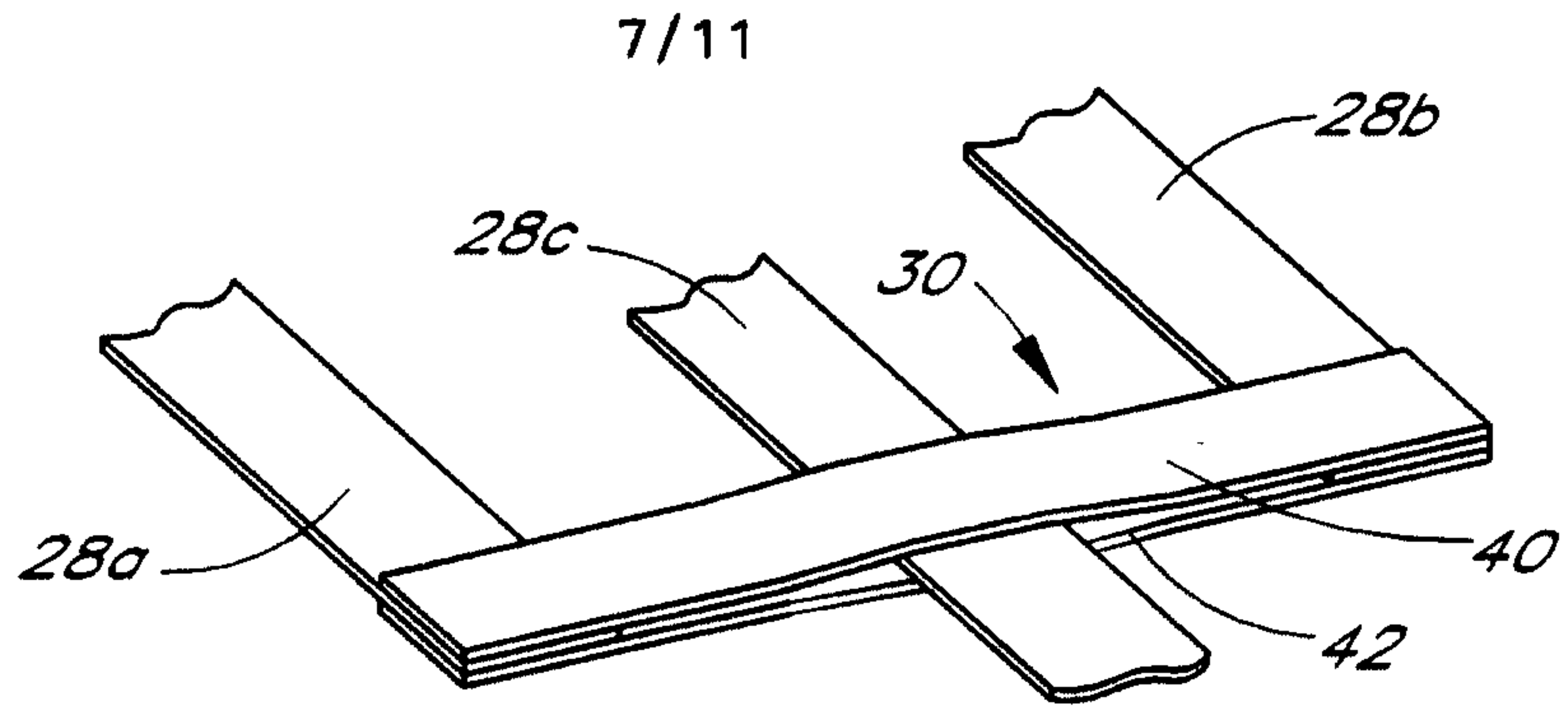

FIG. 7

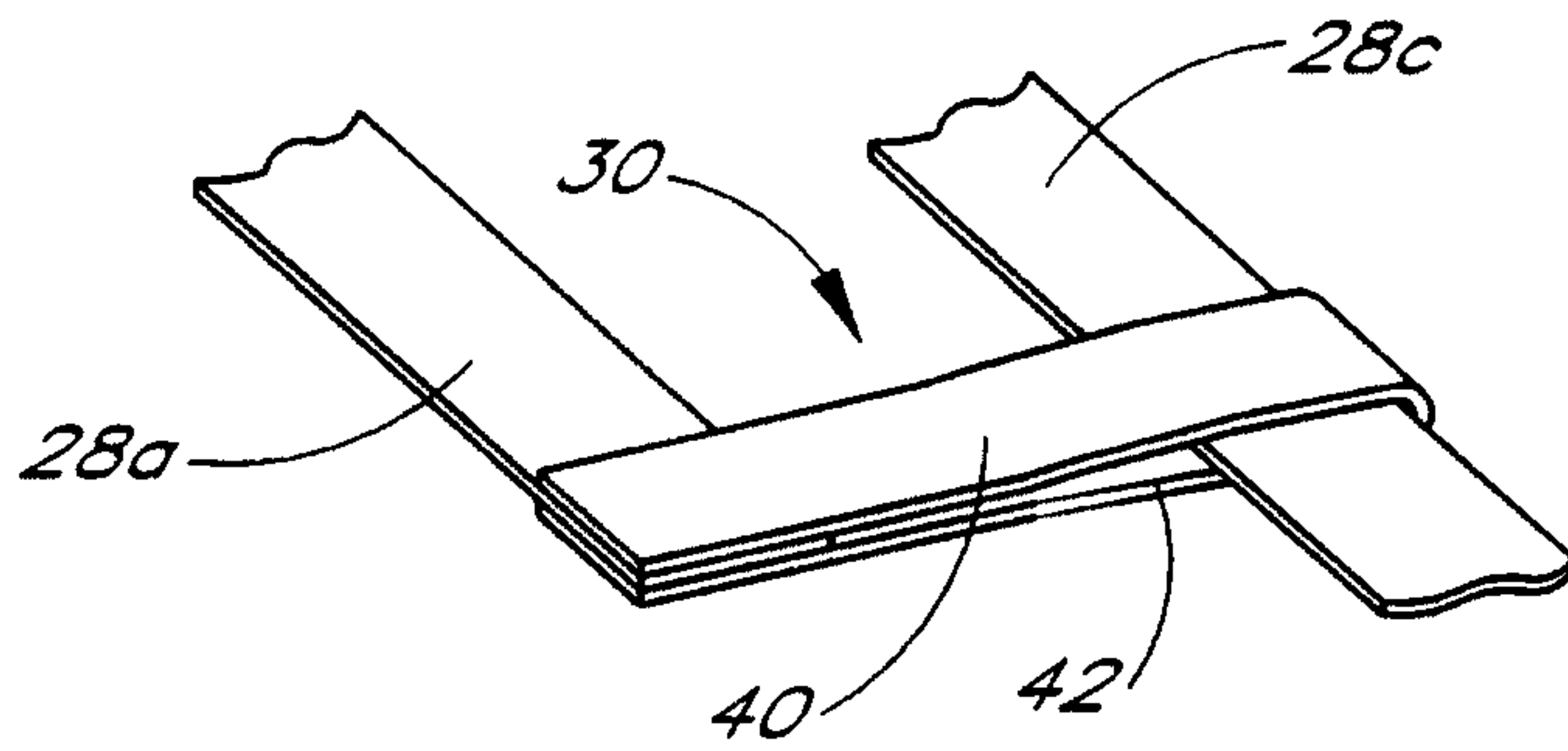

FIG. 8

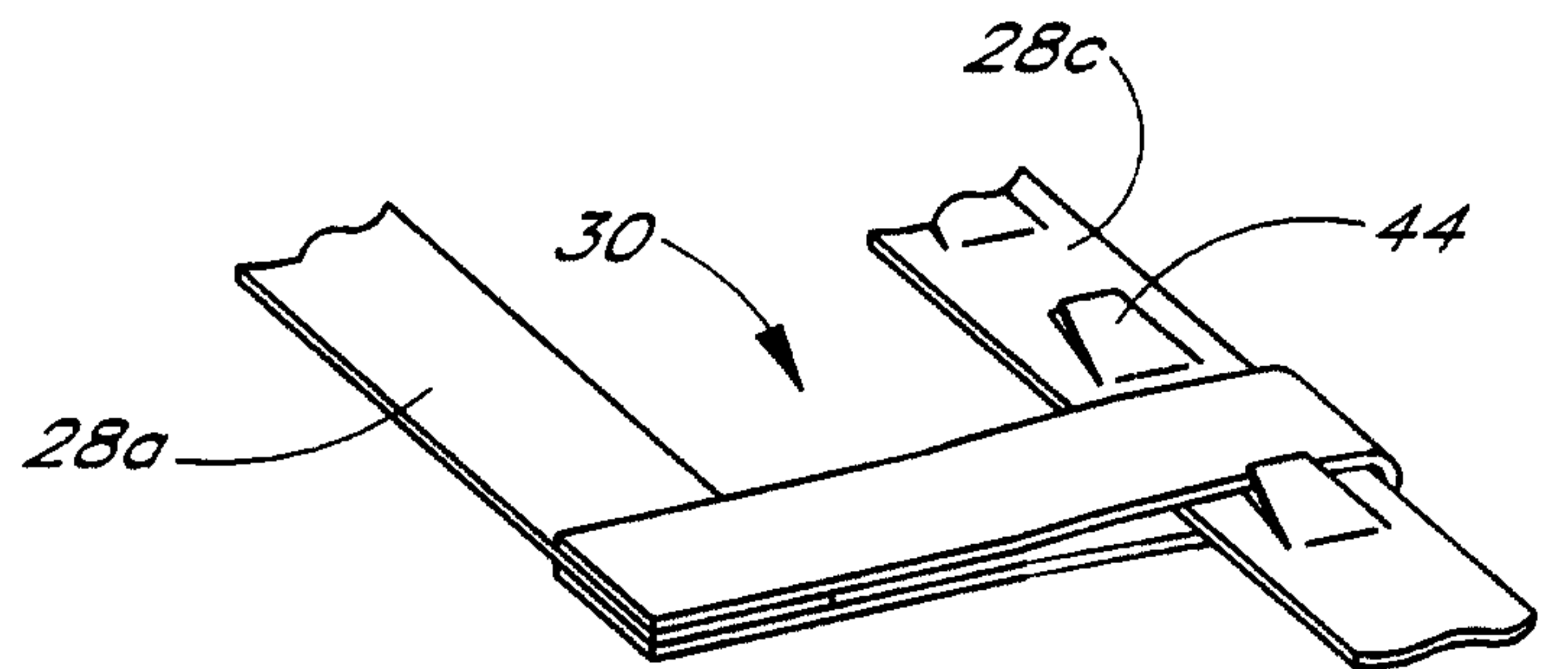

FIG. 9

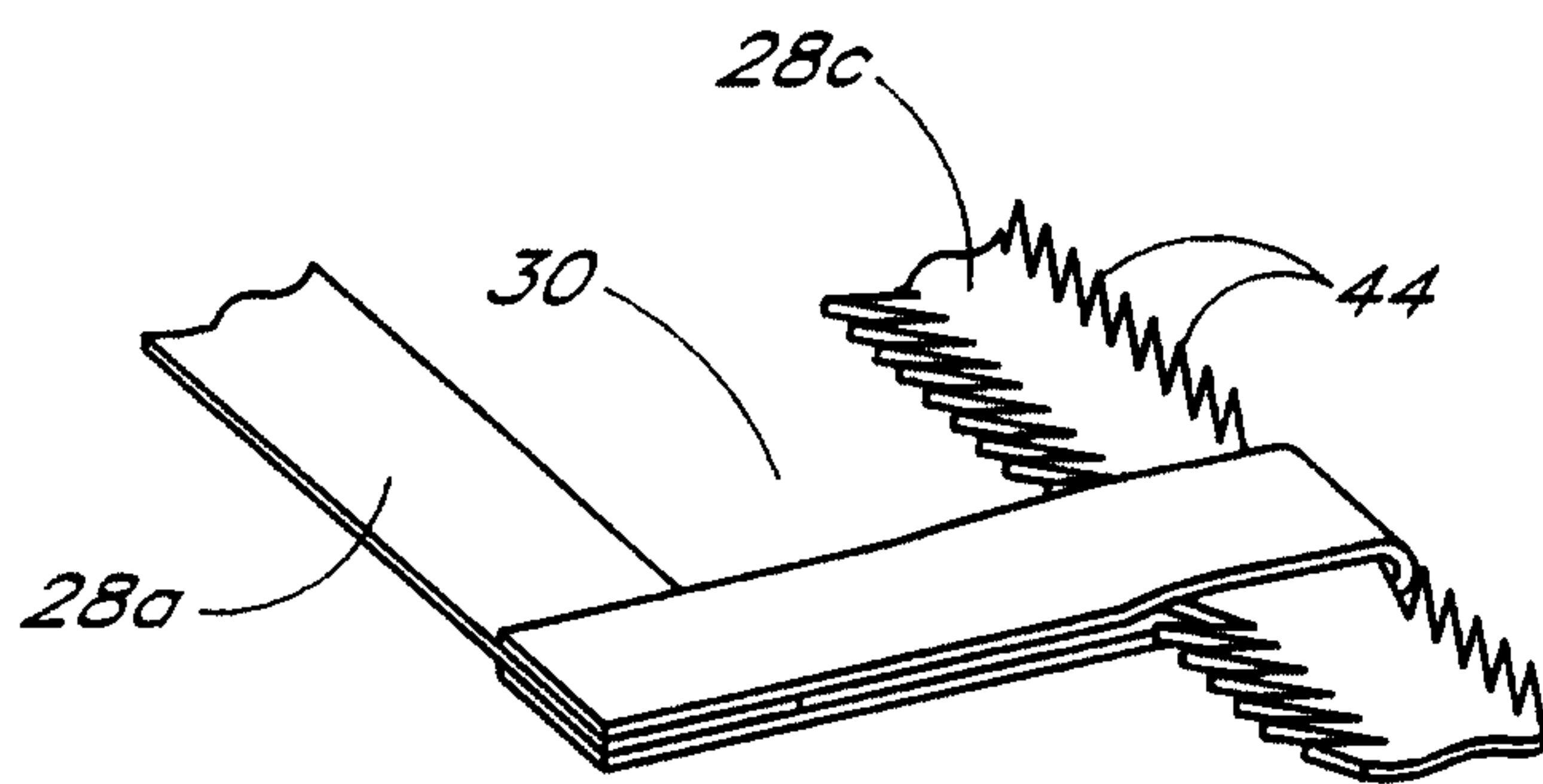

FIG. 10

8/11

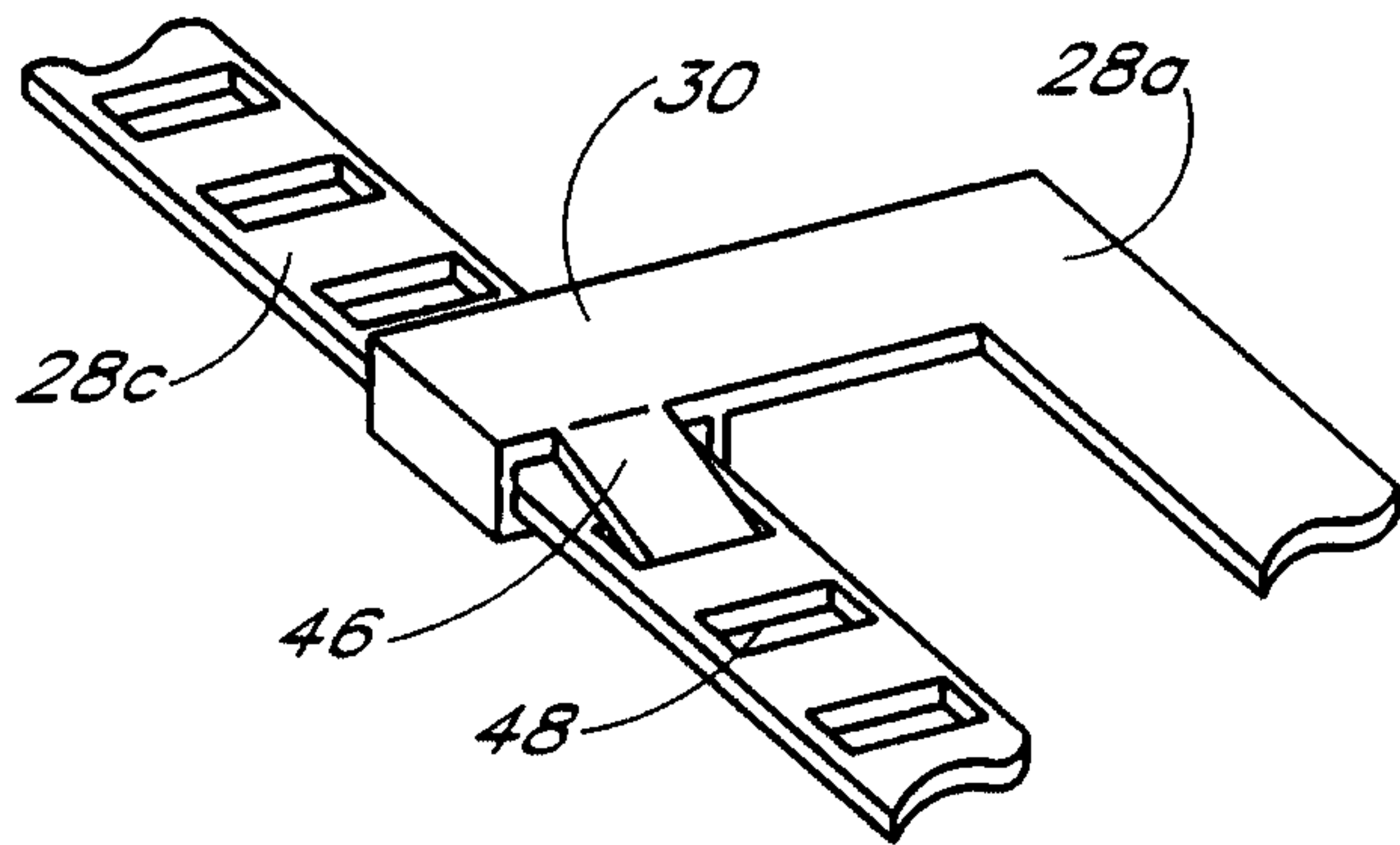

FIG. 11

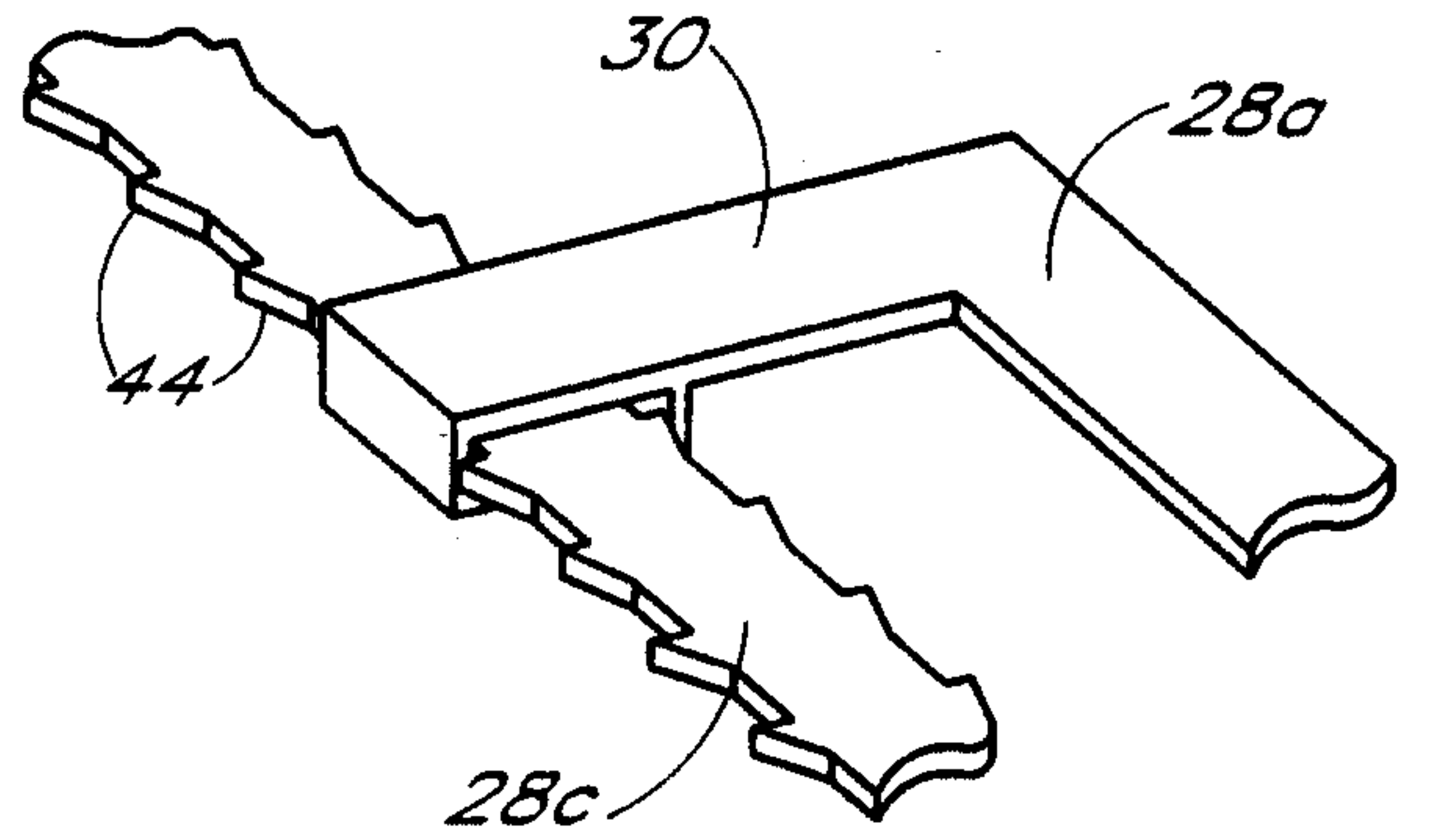

FIG. 12

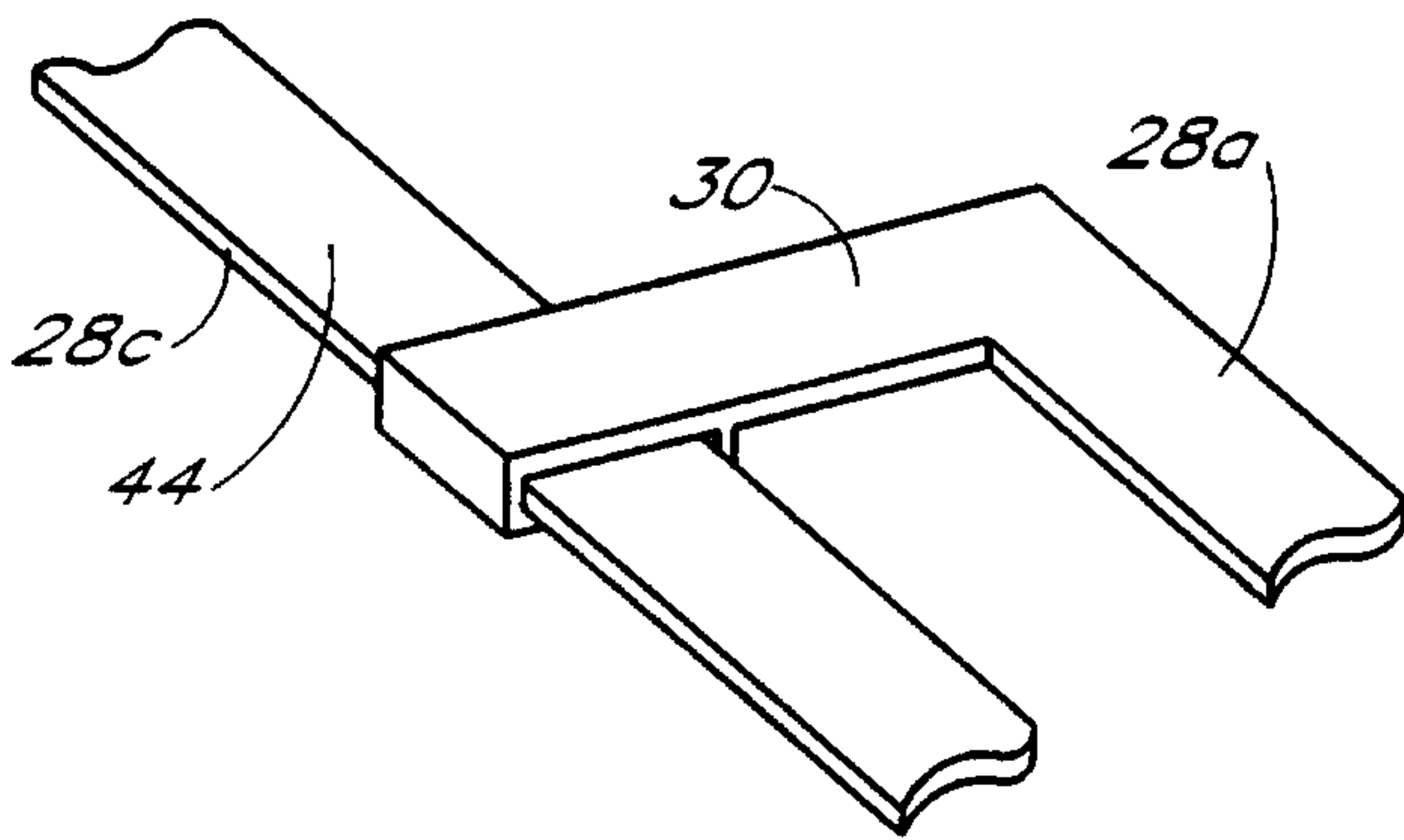

FIG. 13

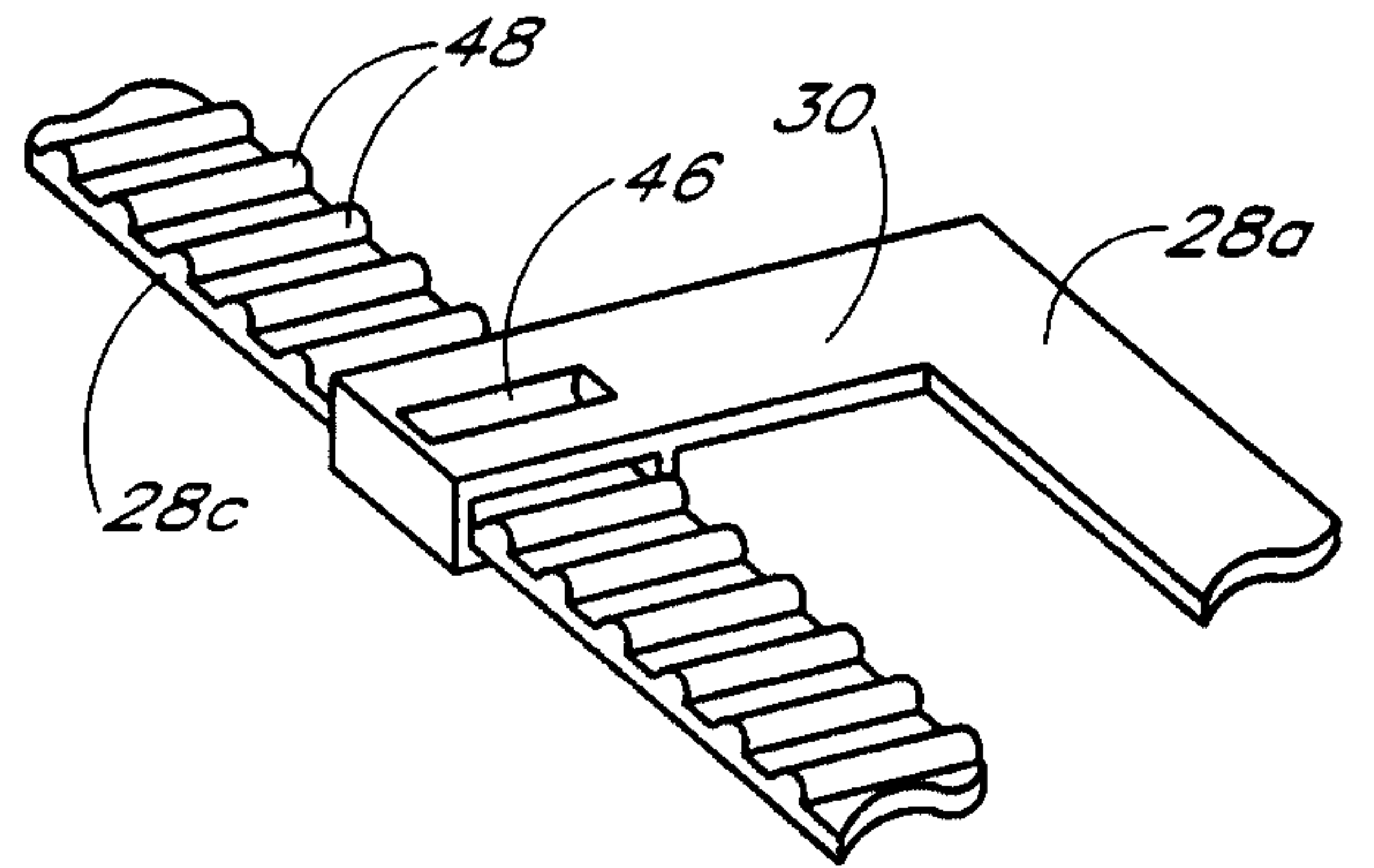

FIG. 14

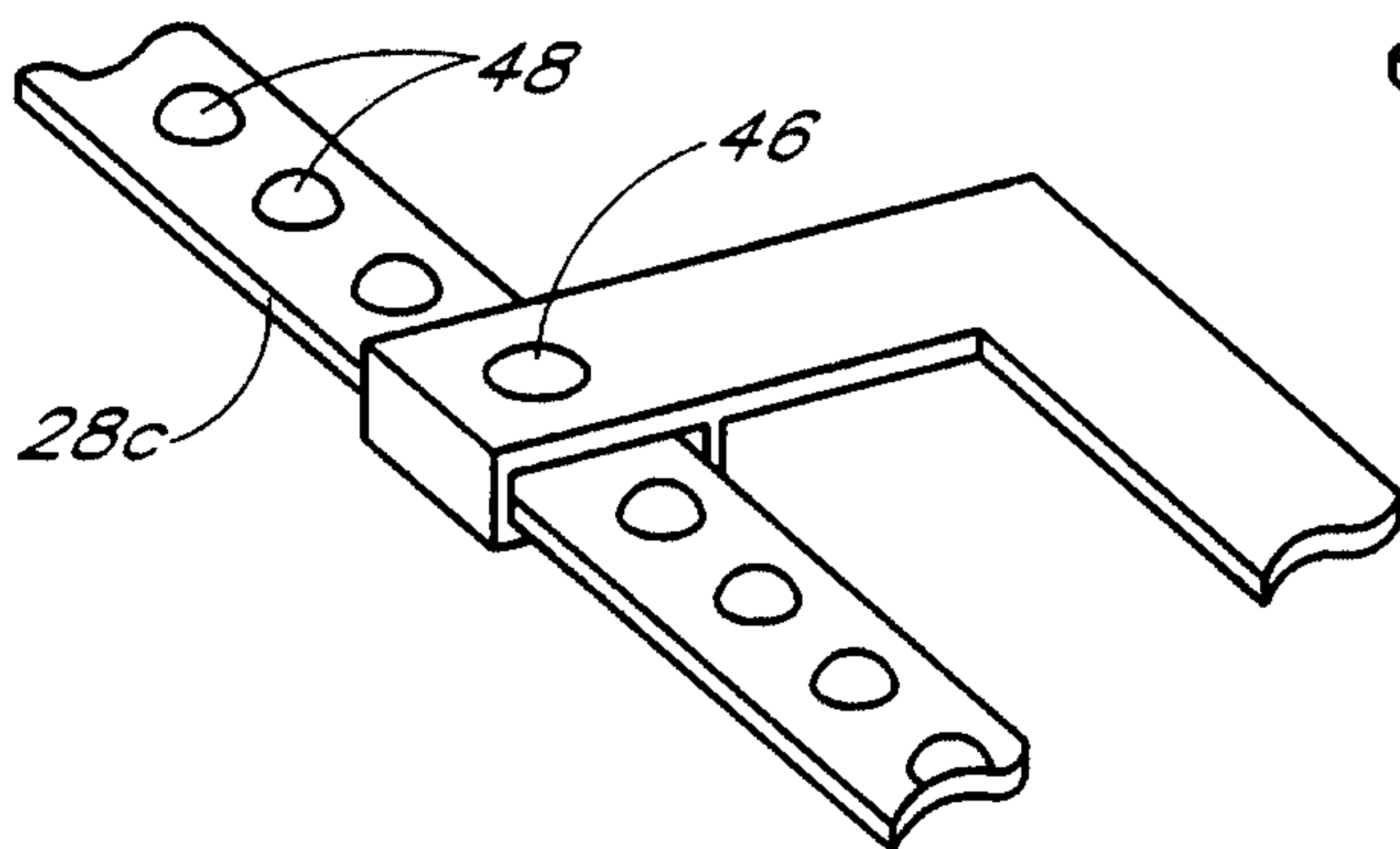

FIG. 15

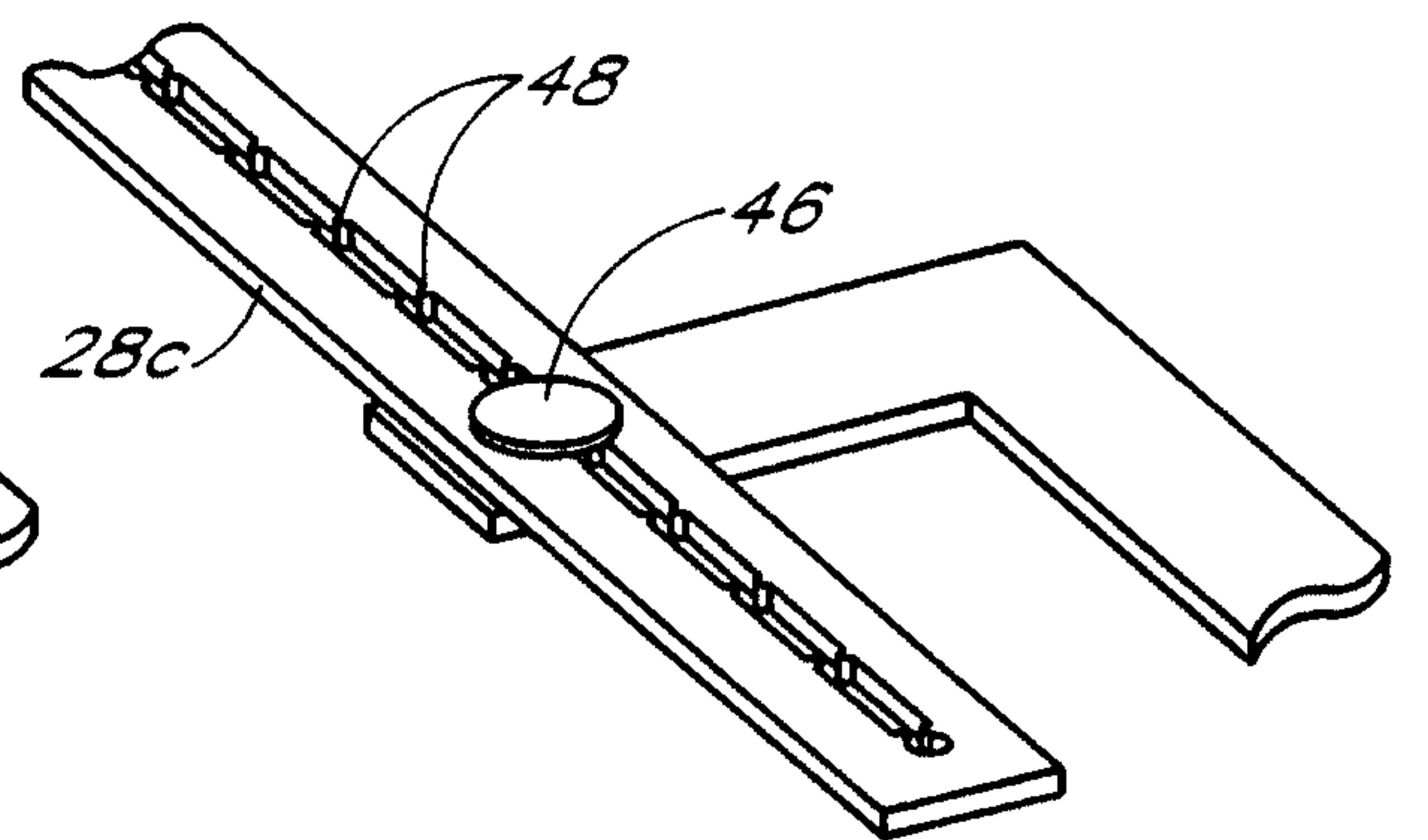

FIG. 16

9/11

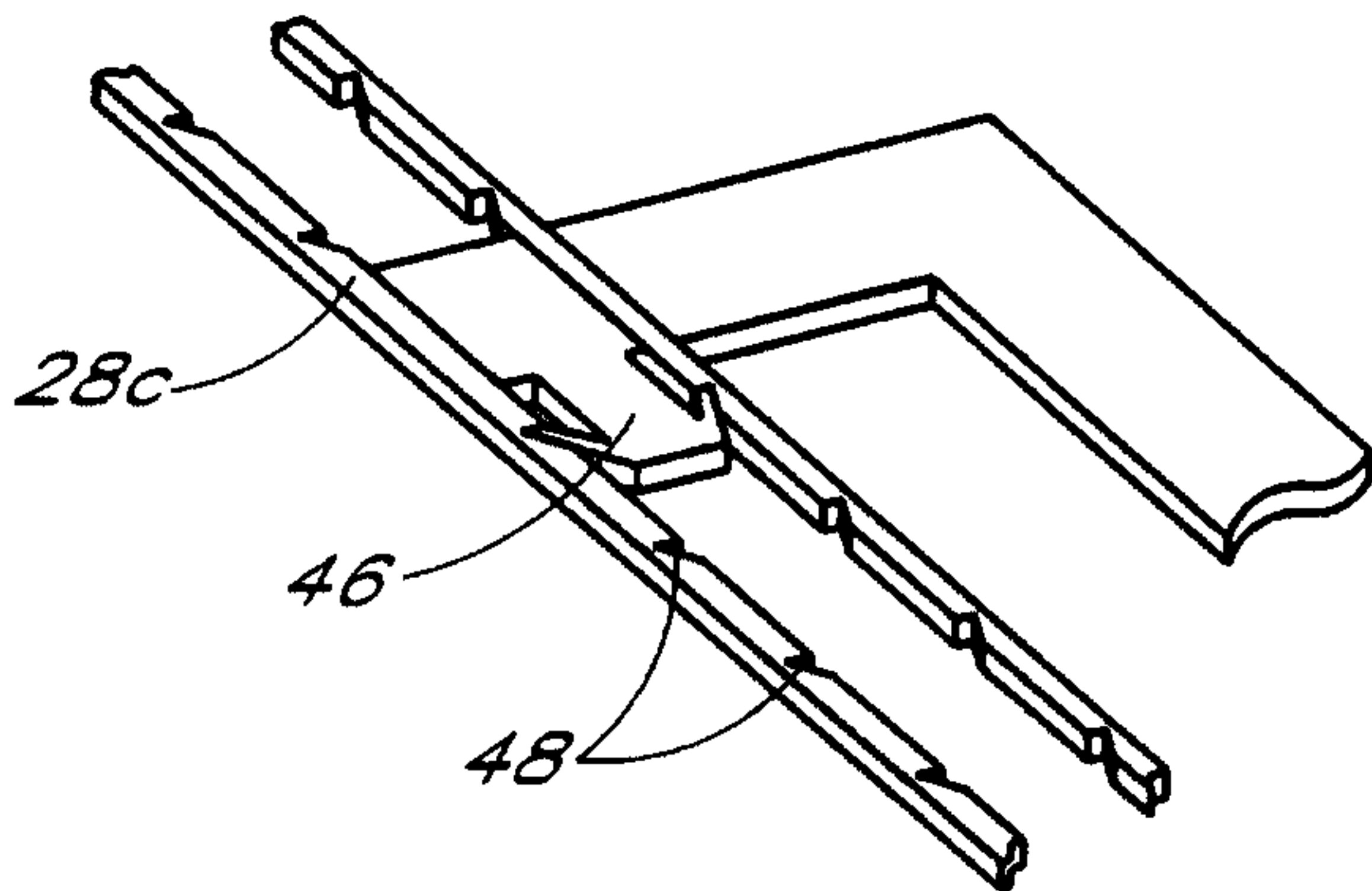

FIG. 17

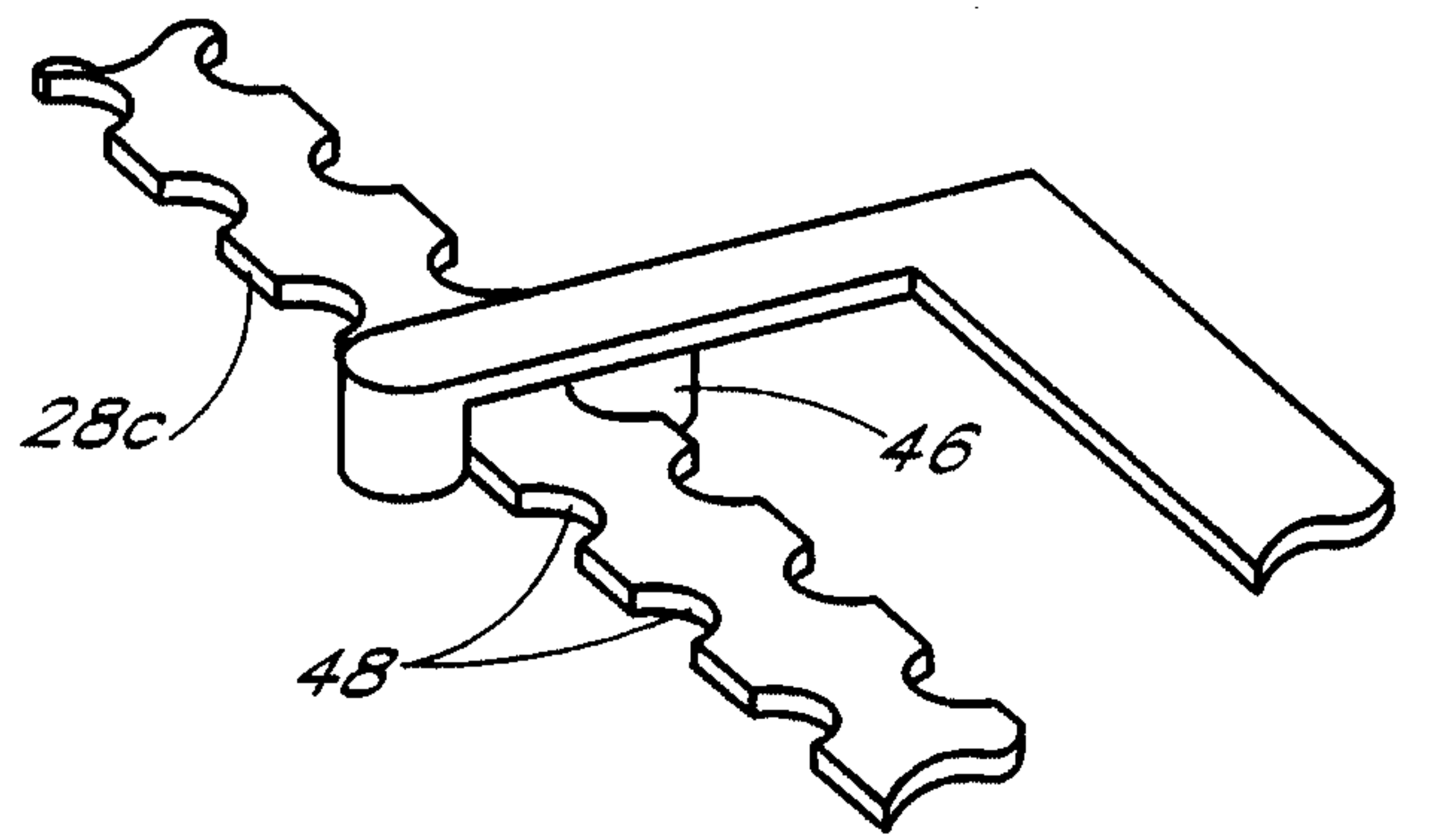

FIG. 18

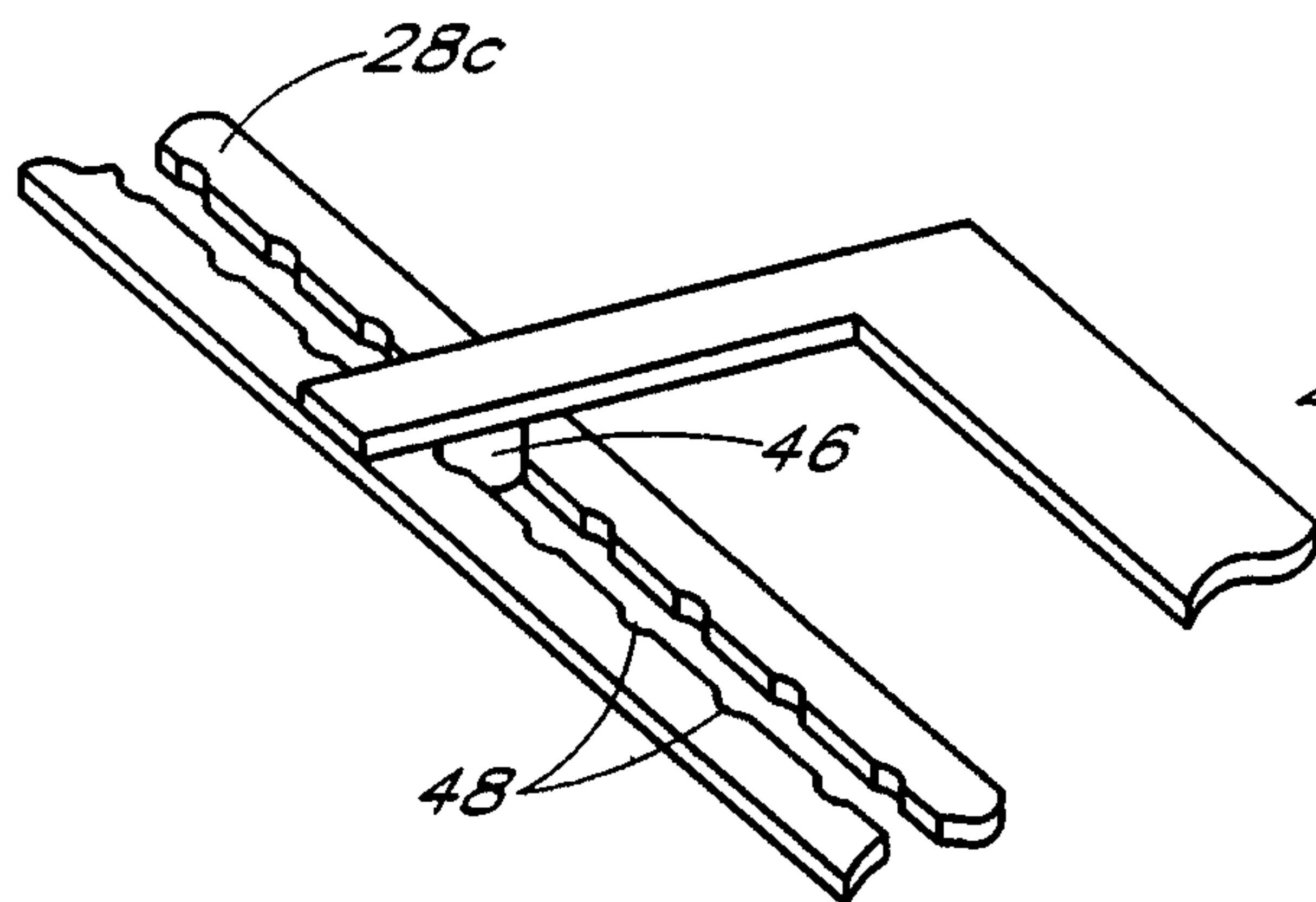

FIG. 19

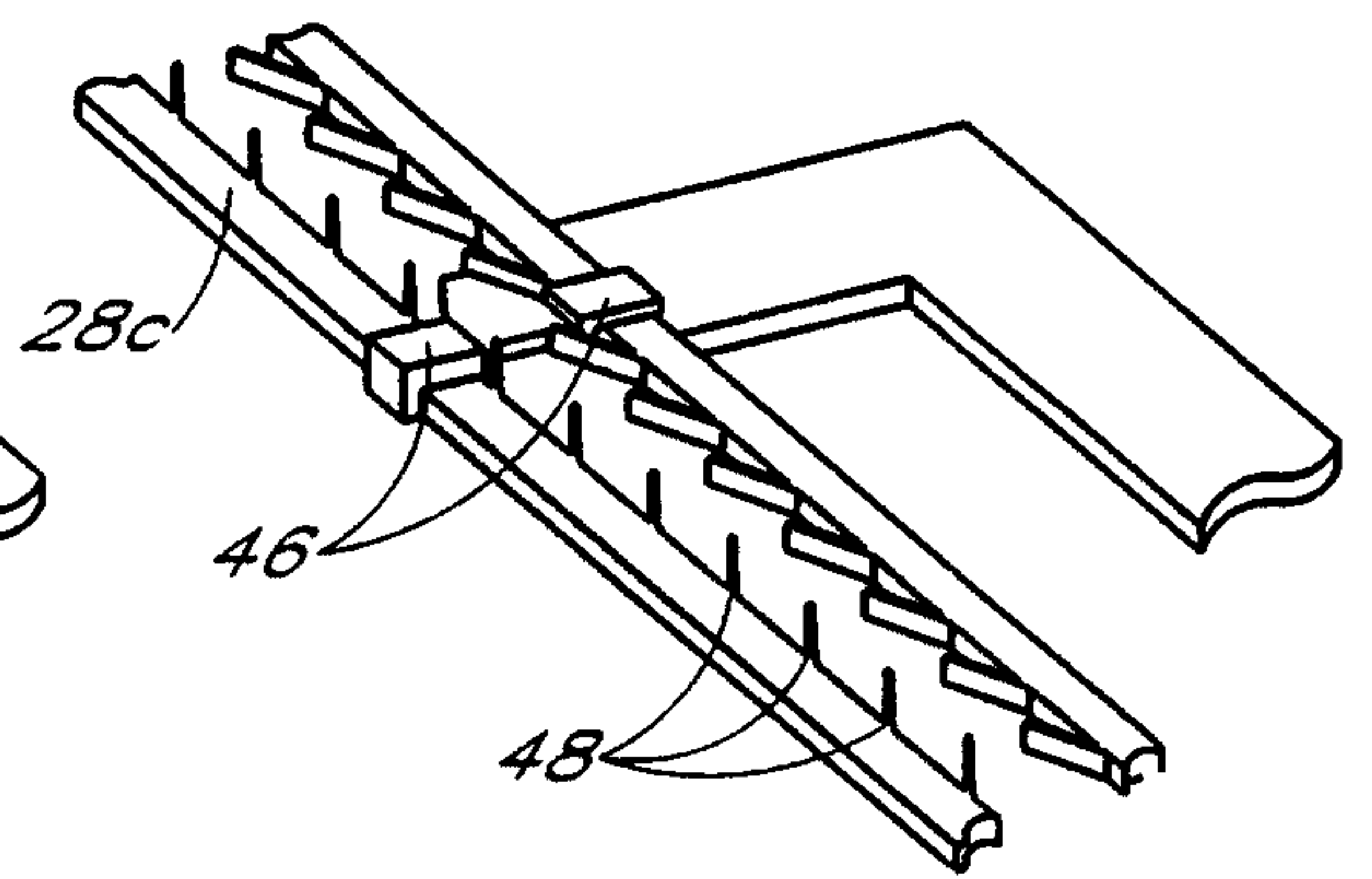

FIG. 20

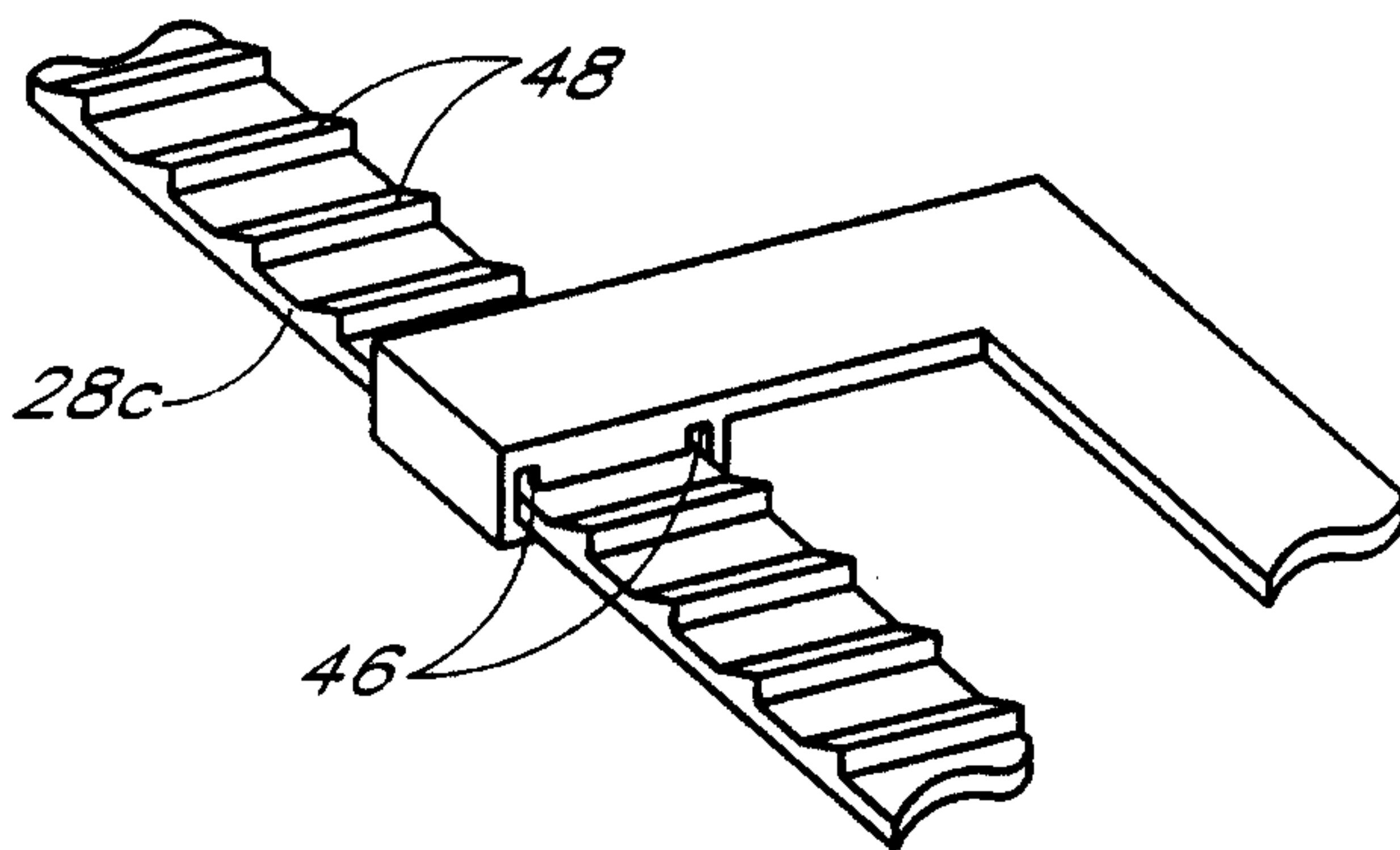

FIG. 21

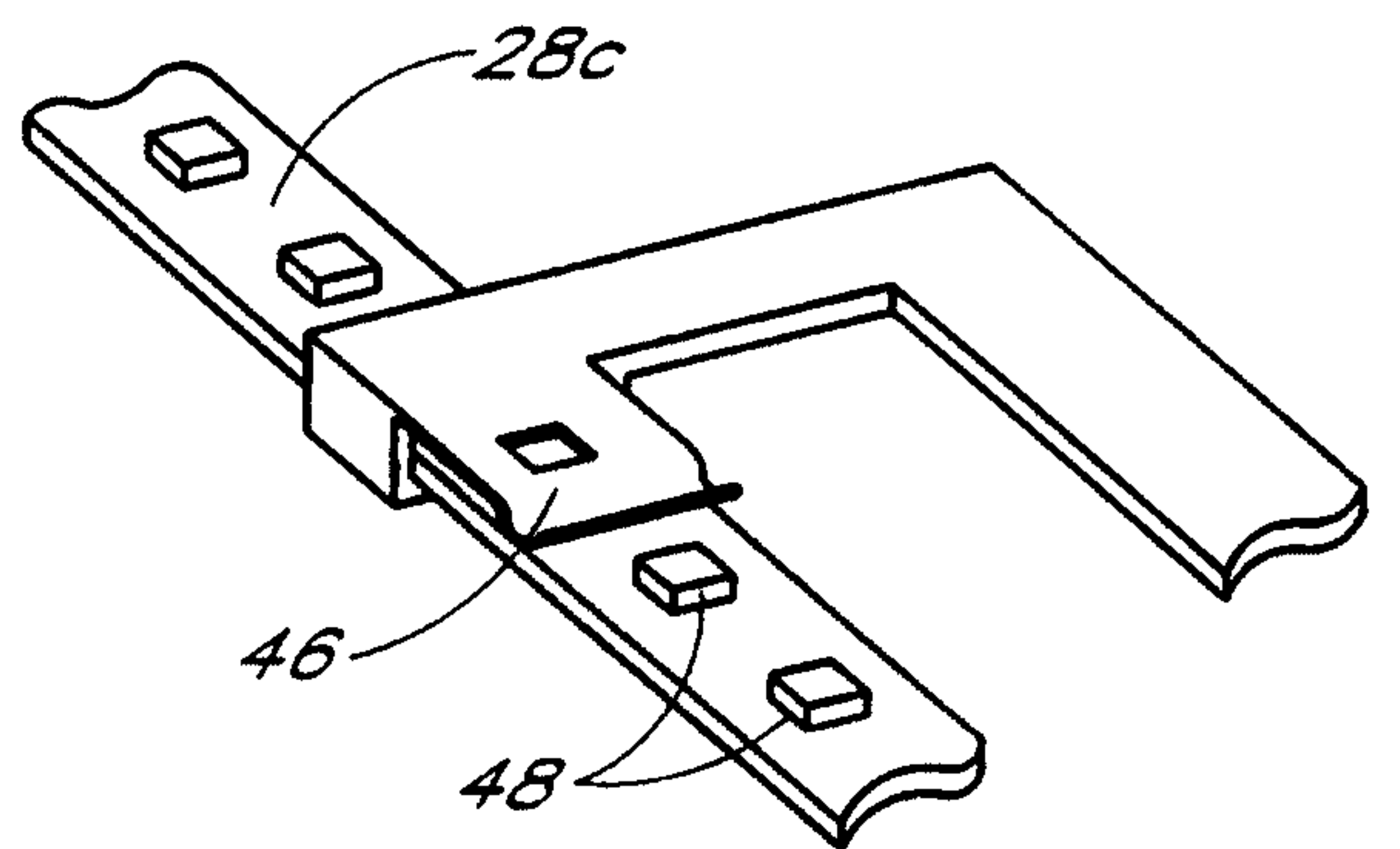

FIG. 22

10/11

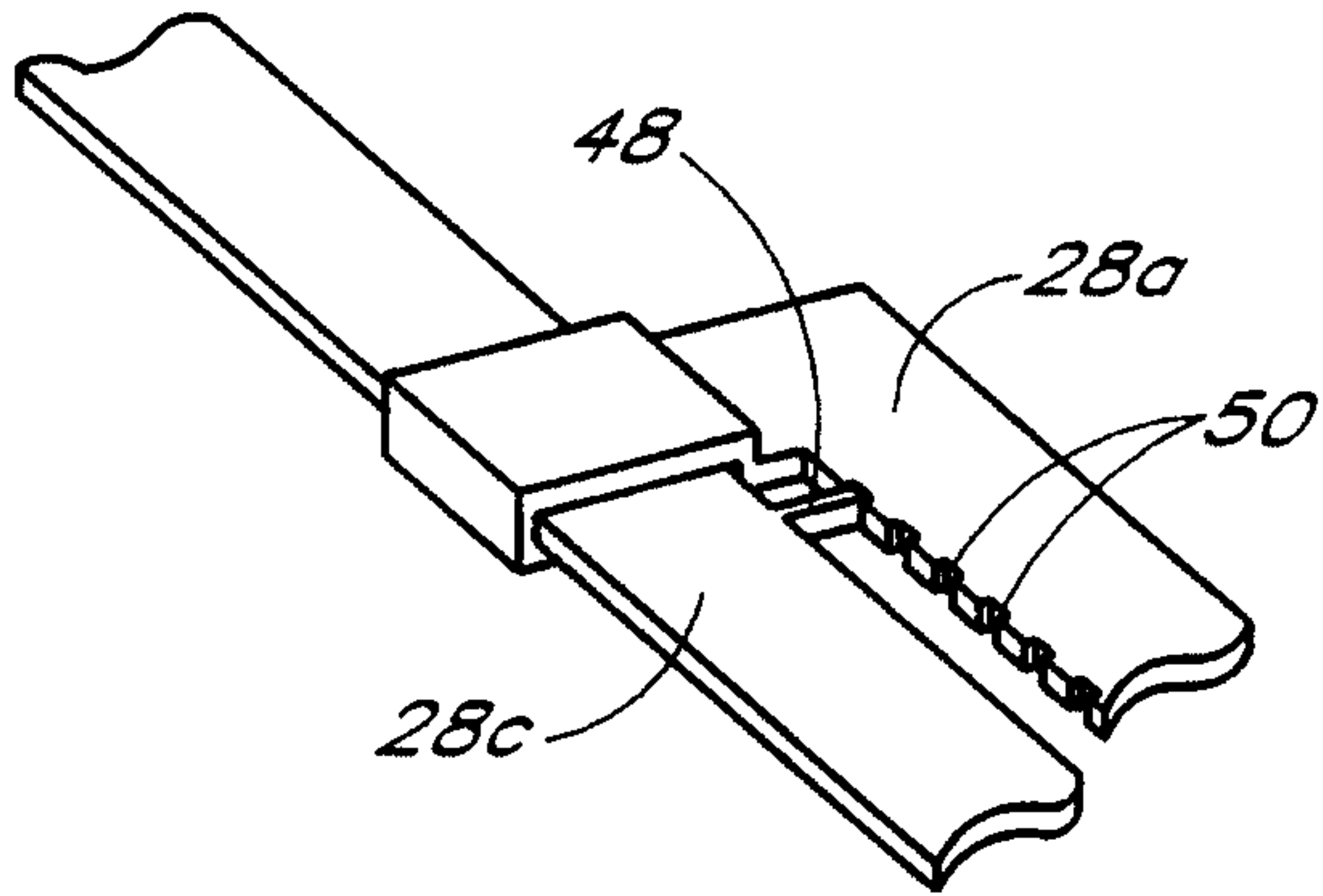

FIG. 23

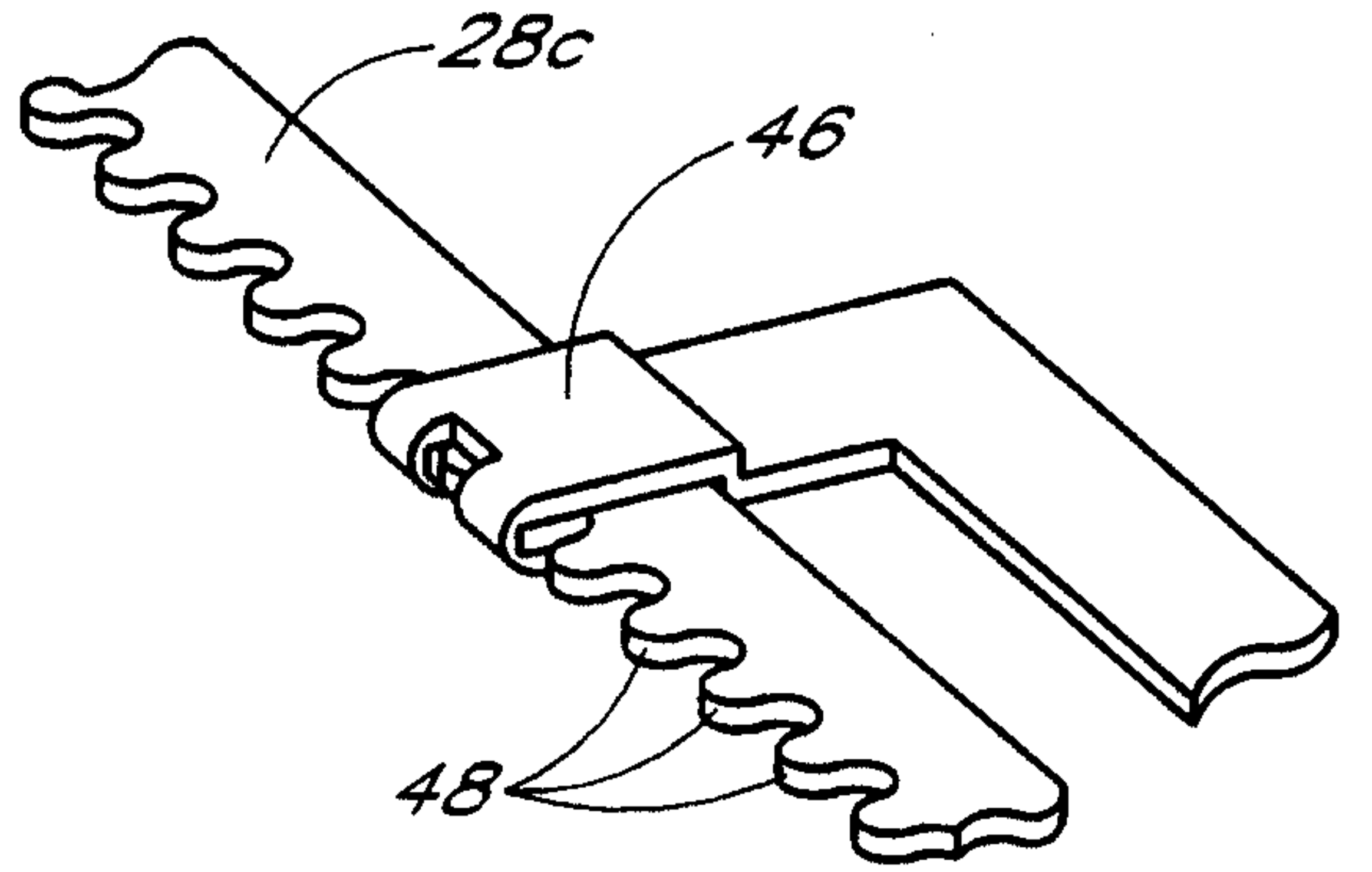

FIG. 24

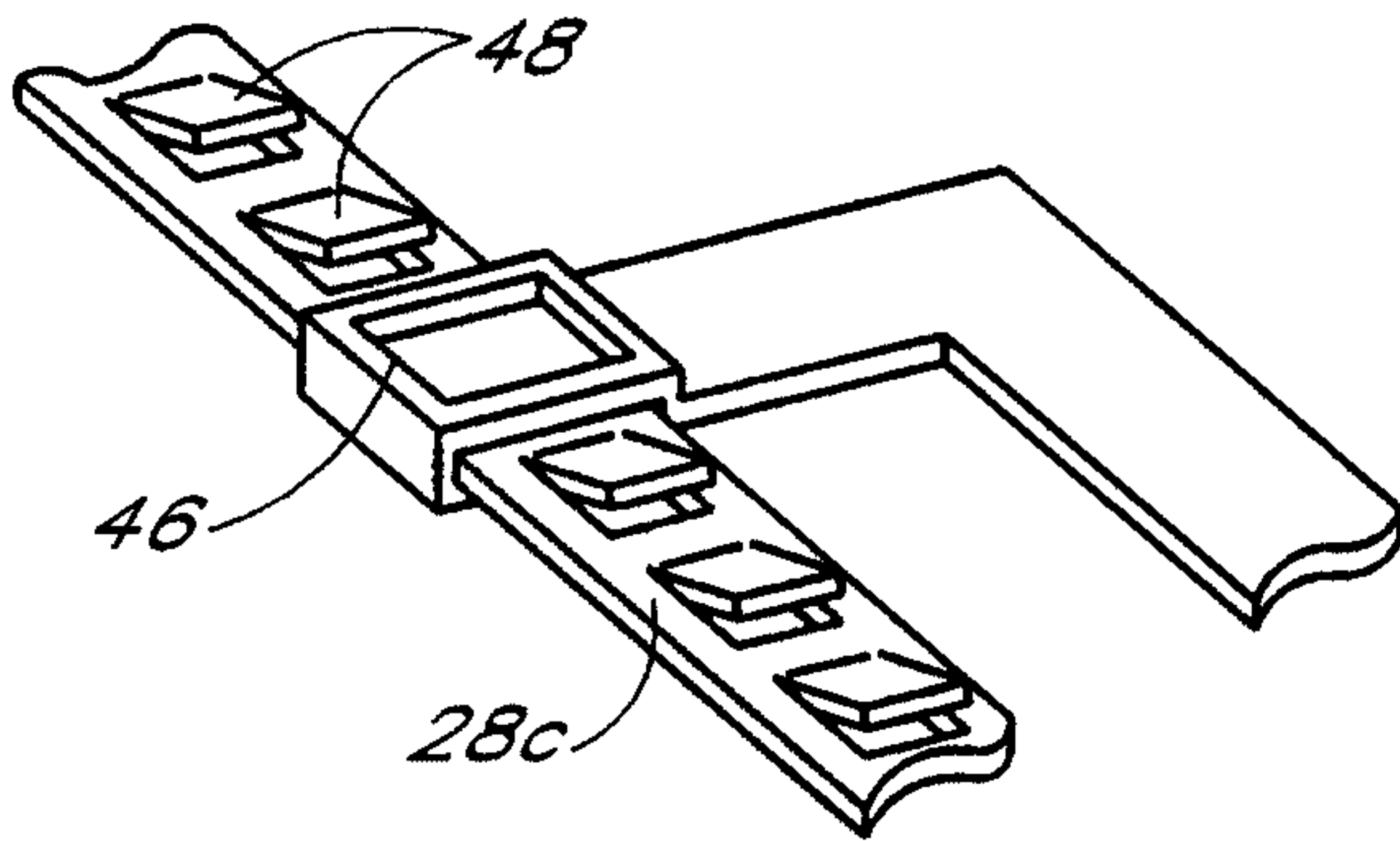

FIG. 25

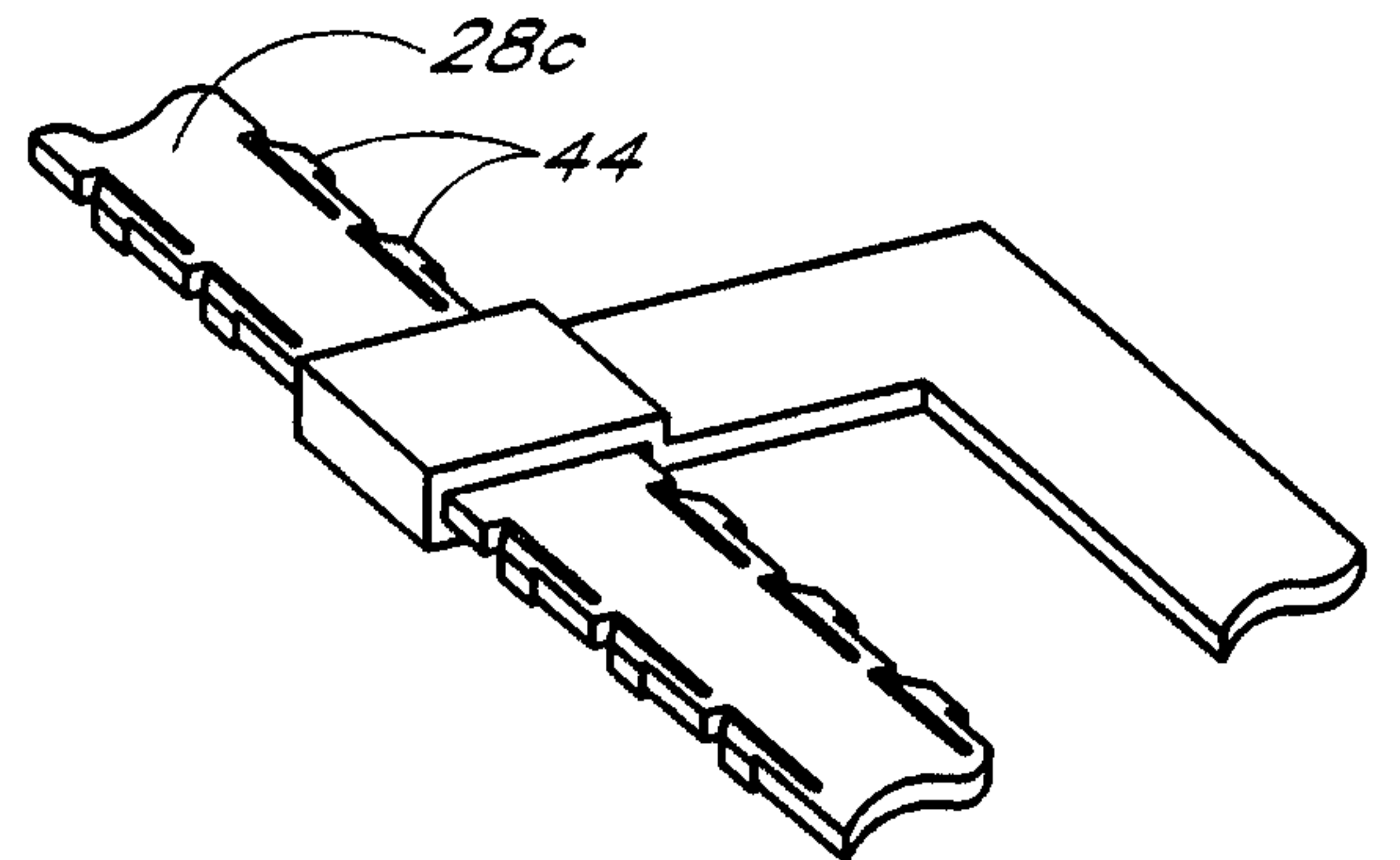

FIG. 26

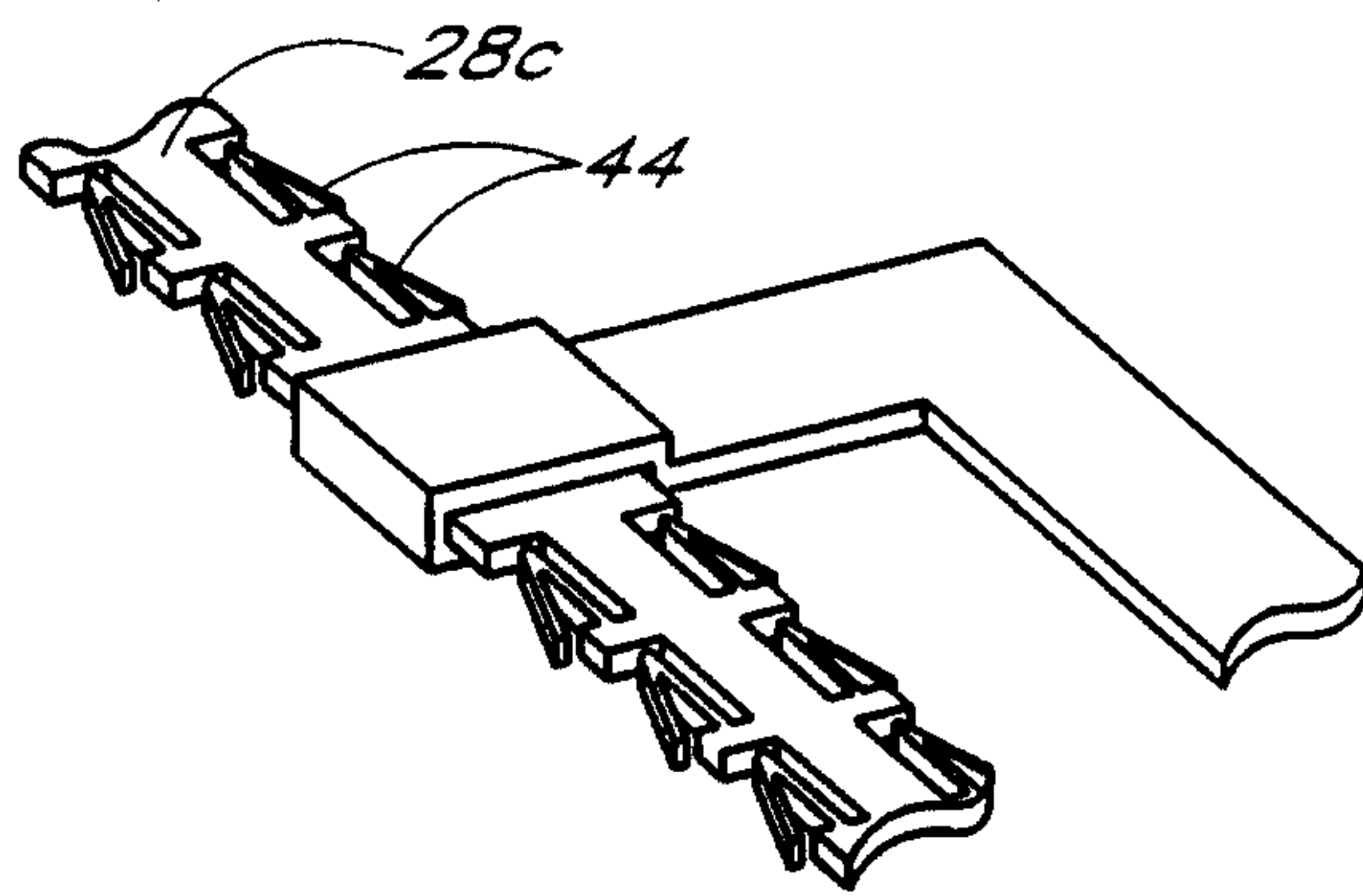
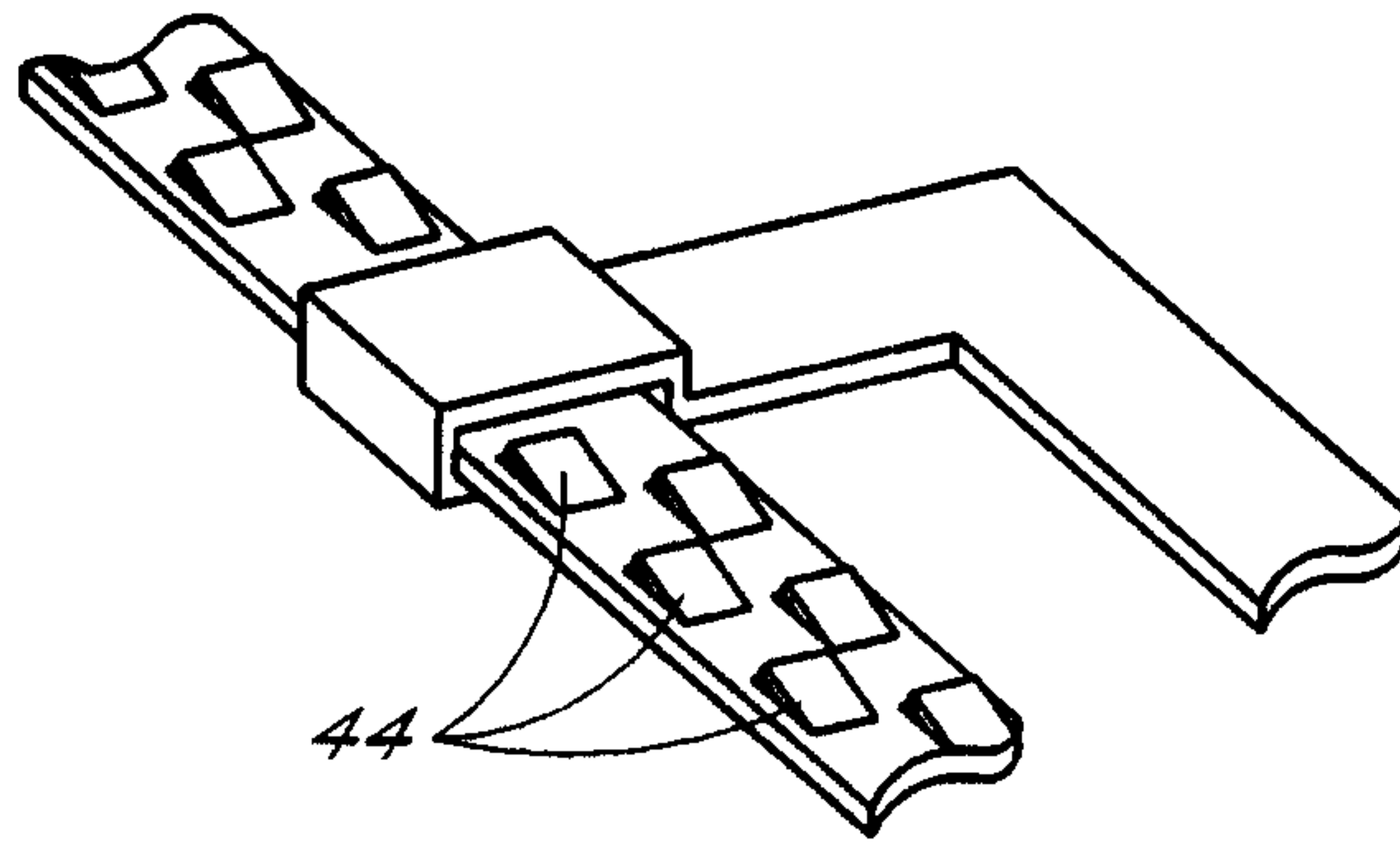
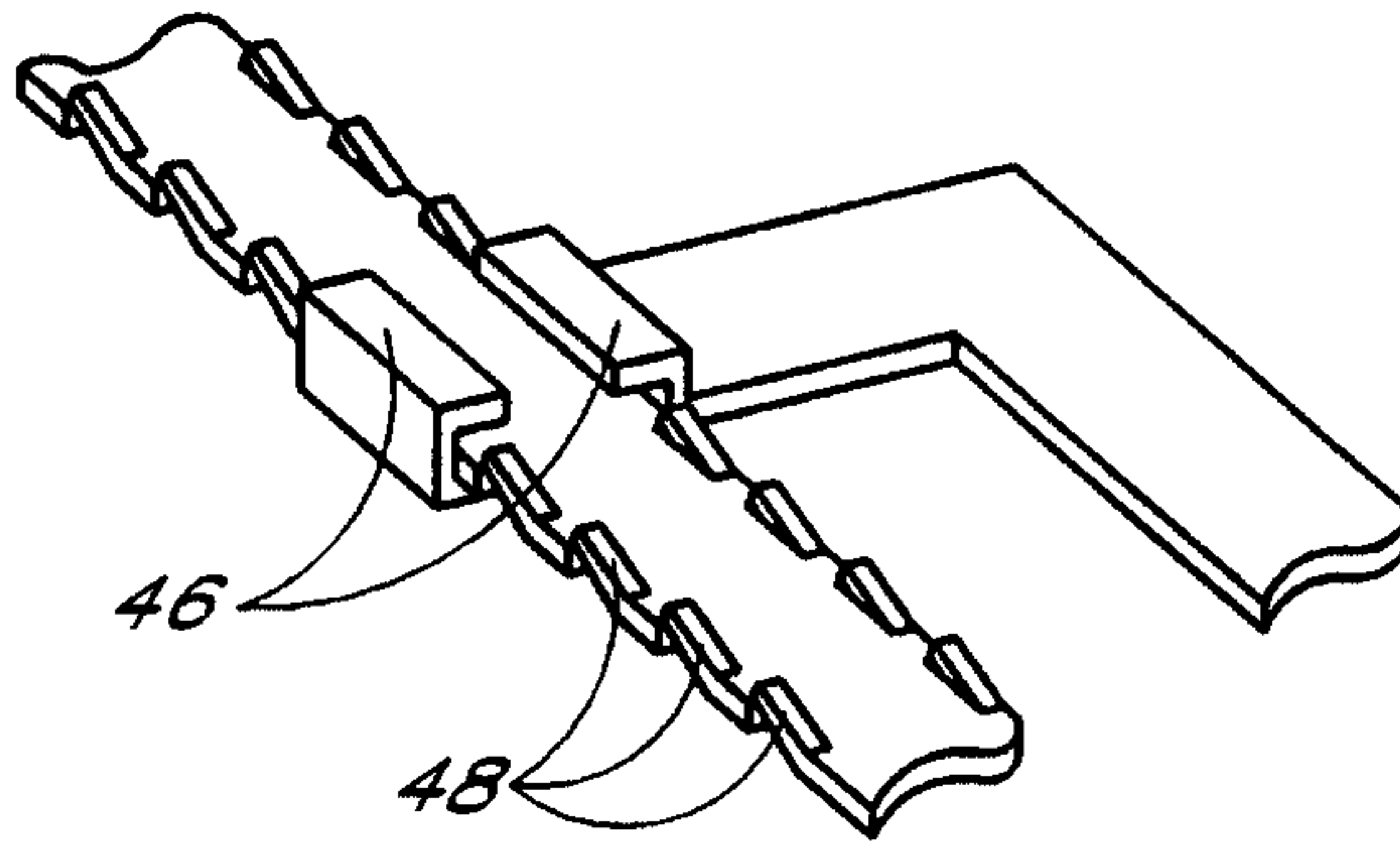

FIG. 27





*FIG. 28*



*FIG. 29*

