

March 7, 1944.

D. W. BINGHAM

2,343,523

FOOD OR LIKE PUMP

Filed Nov. 14, 1942

2 Sheets-Sheet 1

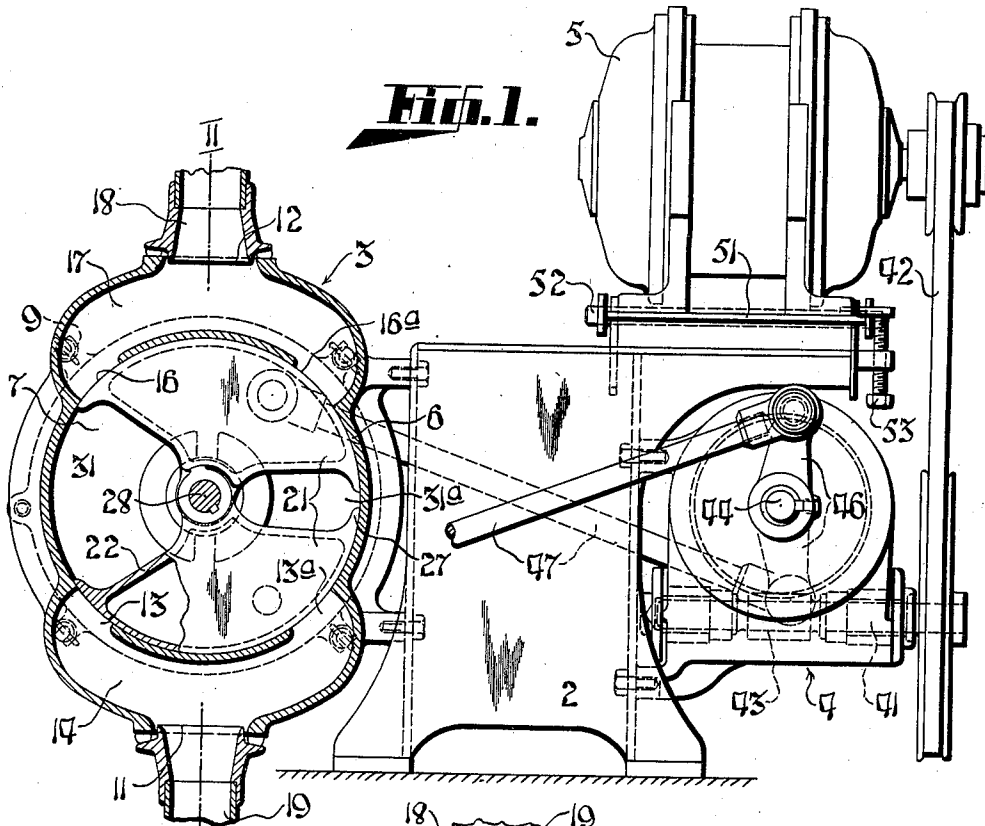
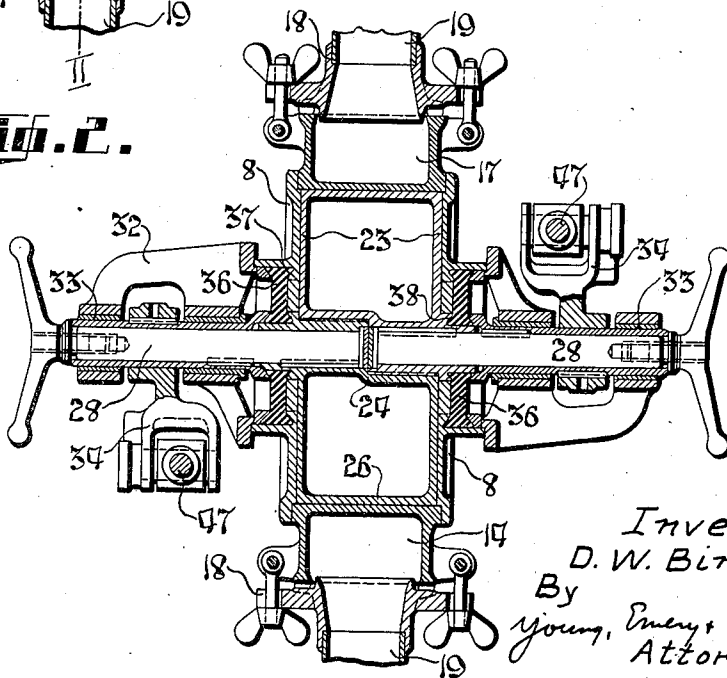

Fig. 2.



Inventor;
D. W. Bingham
By
Young, Emery & Thompson
Attorneys

March 7, 1944.

D. W. BINGHAM

2,343,523

FOOD OR LIKE PUMP

Filed Nov. 14, 1942

2 Sheets-Sheet 2

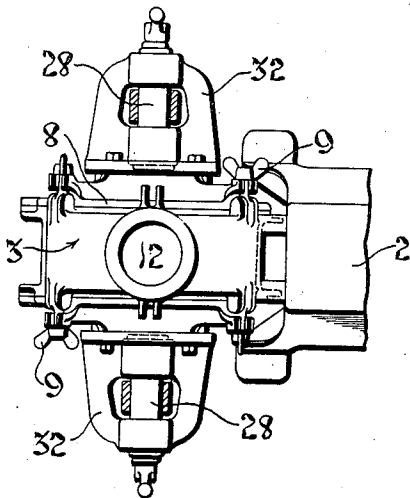

Fig. 3.

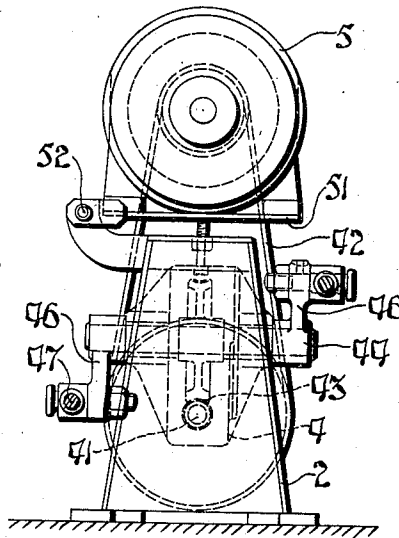

Fig. 4.

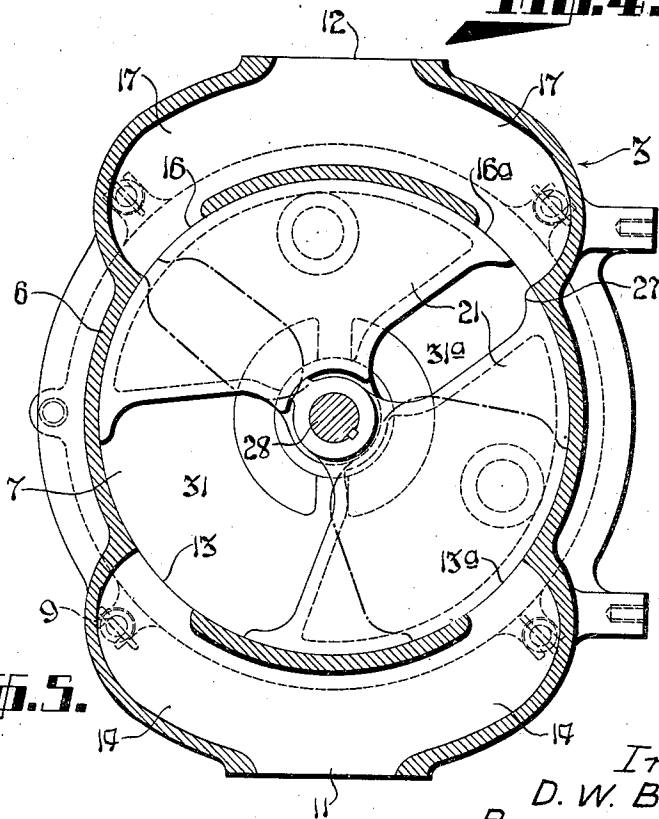

Fig. 5.

Inventor;
D. W. Bingham
By
Young, Egan, Thompson
Attorneys

UNITED STATES PATENT OFFICE

2,343,523

FOOD OR LIKE PUMP

David William Bingham, Middle Brighton,
Victoria, AustraliaApplication November 14, 1942, Serial No. 465,622
In Australia December 18, 1941

12 Claims. (Cl. 103—166)

This invention relates to pumps for passing various classes of food and other liquids containing solids through pipes or passages. For example, the pump is particularly suitable for conveying jam, soup and other food from a reservoir or hopper to a can filling machine.

One of the objects of the present invention is to provide an improved pump for the purpose indicated which is devoid of valves and is adapted to operate at a relatively low speed, thus avoiding mashing and beating or aerating the food product.

Another important feature is that the construction and arrangement of parts of the pump is such that all of the parts are readily accessible for cleaning purposes. Furthermore, the pump is capable of being easily reversed, if so desired, for passing a cleaning liquid therethrough.

Referring to the drawings which form part of this specification—

Figure 1 is a side elevation of a food or like pump and driving means therefor in accordance with the present invention, the pump being shown in section.

Figure 2 is an enlarged sectional elevation taken on the line II—II of Figure 1.

Figure 3 is a part sectional plan view on a reduced scale, of the pump.

Figure 4 is a view on a reduced scale looking at the left-hand side of the pump driving mechanism seen in Figure 1, the pump being omitted for convenience of illustration.

Figure 5 is an enlarged sectional elevation showing the movements of a pair of oscillating jaws in the pump during the pumping operations.

According to one practical embodiment, the improved food or like pump includes a supporting standard 2 carrying a pump assembly 3, driving mechanism 4 therefor, and any suitable source of power such as an electric motor 5 for actuating the driving mechanism.

The pump assembly includes a main casing 6 having a central pump chamber 7 of substantially circular formation and fitted with removable side plates 8. Any suitable type of screw or like clamping means 9 may be provided for securing the side plates upon the casing.

The pump is provided with inlet and outlet openings 11 and 12 respectively which may be oppositely disposed, for instance, at the top and bottom of the main casing. Each of said inlet and outlet openings communicates with the central chamber 7 preferably through a plurality of ports and passages. For example, a pair of cir-

cumferentially spaced inlet ports 13, 13a may communicate by means of a substantially Y-shaped passage 14 with the inlet opening, whilst a similar pair of outlet ports 16, 16a and a Y-shaped passage 17 may be associated with the outlet opening. The pairs of inlet and outlet ports may be substantially oppositely disposed around the central chamber.

Each of the inlet and outlet openings 11, 12 may be provided with a clamping socket 18 and any suitable sealing means whereby pipes or flexible conduits 19 may be detachably connected thereto.

Mounted within the chamber so as to oscillate therein is a pair of independently movable arcuate jaws 21, each of which may comprise opposite end and side walls 22, 23 mounted upon a boss 24 and carrying a curved outer wall 26 opposite to the boss. The opposite end portions of the curved wall may overhang said opposite end walls so as to form lips or the like 27.

A pair of axially aligned shafts 28 is provided for carrying the pair of jaws and oscillating the latter in opposite directions, as hereinafter described.

The arcuate length of the outer curved surface of each of the aforesaid jaws 21 is less than half the circumference of the inner surface of the wall of the central pump chamber 7 so that relative circumferential movement may occur between the two jaws at the same time as they are being oscillated.

The variable gaps so formed between the adjacent ends of the opposed jaws constitute mouths 31, 31a which are adapted to open automatically for filling when in registry with one of the aforesaid inlet ports 13, 13a and to close automatically for discharging their contents when in registry with one of the outlet ports 16, 16a. The arrangement is such that when one of the mouths is being filled the other mouth is being emptied.

Each of the aforesaid side plates 8 may be provided with a bracket 32 fitted with bearings 33 for carrying one of the shafts 28. Each shaft is provided with a crank arm 34 for oscillating its jaw. One of said crank arms may extend upwardly of its shaft, whilst the other crank arm may extend in a downward direction.

In order to prevent the escape of fluid from the pump casing, rubber or like sealing rings or washers 36 may be mounted on said side plates so as to surround the associated shaft. The outer edge portion of each said sealing ring may be clamped as at 37 to its associated side plate 8, whilst the inner edge portion of the ring may be similarly clamped as at 38 to its arcuate jaw,

The arrangement is such that relative bodily movement does not occur between each sealing ring and either its jaws or its associated side plate, although the resilient properties of the ring permit it to flex during the oscillatory movements of its jaw.

The aforesaid driving mechanism 4 may be mounted on that side of the supporting standard 2 remote from the pump casing and may comprise a shaft 41 connected to the electric motor 5 by a belt drive 42 and geared as at 43 to another shaft 44. The latter carries a pair of substantially oppositely disposed crank arms 45 which may be located on opposite ends of the driving shaft 44 and be connected, one with each of the crank arms 34 on the pump shafts by means of connecting rods 47. The effective length of the cranks on the driving shaft is less than that of the cranks on the pump shafts, whereby rotation of the driving cranks 45 imparts oscillation to the pump shafts 28 and to the jaws carried thereby. Furthermore, during the oscillatory movements of the jaws, relative circumferential movement occurs therebetween, thus opening and closing the aforesaid mouths 31, 31a discharging the food alternately through each of the outlet ports 16, 16a leading to the discharge opening.

The combination and arrangement of parts of the driving mechanism 4 including the relative lengths of the crank arms 34 and 46, the connecting rods 47 and the pair of jaws 21 is such that little, if any, relative circumferential movement occurs between the jaws whilst the mouths 31, 31a are out of registry with the inlet and outlet ports during part of the oscillatory movements of the jaws as in Figure 1 of the drawings. If desired vent holes (not shown) may be formed through the jaw bosses 24 to compensate for any slight relative jaw movement that may occur during such periods.

The electric motor 5 may be carried by a support 51 which is pivotally mounted at one side as at 52 upon the supporting standard and provided at its opposite side with one or more elevating screws 53, whereby the belt connecting the motor to the aforesaid driving shaft 41 may be readily tensioned, simply by turning the elevating screw to raise the motor.

In use, when one of the aforesaid mouths 31 registers with its inlet port 13, it automatically opens and is thus filled by suction with food from the inlet 11. During the return movement of the jaws, the filled mouth is kept open until it registers with its outlet port 16, whereupon the mouth is automatically closed for discharging its contents through the outlet port. Whilst this operation is proceeding, the other mouth 31a is being filled at the second inlet port 13a for subsequent discharge at the second outlet port 16a, as seen more clearly in Figure 5.

It will be appreciated from the foregoing that the improved pump is double acting in that it effects a delivery of the material being pumped during each backward and forward oscillation of the jaws and thus functions to maintain a steady flow of fluid or the like through the inlet and outlet pipes or conduits 19. No glands are employed which might be likely to leak, whilst, in addition, there is no possibility of the food product being contaminated with lubricant. As all internal passages are of relatively large cross section, no difficulty is experienced in cleaning such passages when required. The driving mechanism is relatively simple and is adapted to en-

able the speed of the pump to be readily varied in accordance with requirements.

It is to be understood that the invention is not limited to the particular type of pump driving mechanism above described but that linkage, gearing or any other suitable mechanism may be employed if so desired. In addition glands or any other suitable sealing means may be substituted for the above mentioned sealing rings or washers 36.

Various other alterations, modifications and/or additions may be incorporated in the foregoing construction and arrangement of parts without departing from the spirit and scope of the invention as defined by the appended claims.

Having now described my invention what I claim as new and desire to secure by Letters Patent is:

1. A pump for food and other material in the form of liquid containing solids, comprising in combination, a main casing having a pump chamber of circular formation, valveless inlet and outlet ports communicating with said chamber, a pair of coaxial independently movable arcuate jaws disposed in said chamber with opposing faces of said jaws enclosing material containing spaces in said chamber, and driving mechanism for oscillating said jaws about their common axis relatively to said inlet and outlet ports and for simultaneously effecting relative circumferential movement therebetween to vary the volume of said material containing spaces, the said relative movement and the said oscillation being so coordinated that when one of said spaces is being enlarged for filling at an inlet port, the other space is being contracted for discharging its contents at an outlet port, said arcuate jaws being arranged to open and close the inlet and outlet openings in proper sequence.

2. A pump according to claim 1, wherein a plurality of valveless inlet ports and a plurality of valveless outlet ports communicate with and are spaced circumferentially of said pump chamber, and the relative and oscillatory movements of the jaws are so coordinated that each of said spaces is filled at a separate inlet port and subsequently emptied at a separate outlet port.

3. A pump for food and other material in the form of liquid containing solids, comprising a main casing having a central pump chamber of circular formation, a plurality of oppositely disposed valveless inlet and outlet ports communicating with the pump chamber through inlet and outlet openings therein, a pair of independently movable arcuate jaws arranged to oscillate in the pump chamber about the central axis thereof, each said jaw consisting of opposite end and side walls mounted upon a boss and carrying a curved outer wall opposite to the boss whereby gaps between the adjacent ends of the opposed jaws form material containing spaces in said chamber which open and close during the oscillatory movements of the jaws, said arcuate jaws being arranged to open and close the inlet and outlet openings in proper sequence.

4. A pump according to claim 3 in which the arcuate length of the outer surface of said curved outer wall is less than half the circumference of the inner surface of the wall of the circular pump chamber.

5. A pump according to claim 3 further comprising a supporting member to which the pump casing is fixed, a driving shaft mounted therein, a pair of substantially oppositely disposed cranks longitudinally spaced on said drive shaft, an in-

dependent shaft for each jaw carried by the pump casing, a crank on each jaw shaft and connecting rods between each drive shaft crank and the respective jaw crank, the driving cranks being shorter than the jaw cranks one of which extends upwardly while the other extends downwardly.

6. A pump according to claim 1, wherein said driving mechanism includes means whereby substantially no relative circumferential movement occurs between the jaws whilst the spaces between them are out of registry with the inlet and outlet ports.

7. A pump according to claim 1, wherein a pair of axially aligned driving shafts are mounted upon the main casing centrally of the pump chamber, each of said shafts carrying one of said jaws which consists of opposite end and side walls mounted upon a boss and a curved outer wall opposite to the boss.

8. A pump according to claim 1, wherein a pair of axially aligned driving shafts are mounted upon the main casing centrally of the pump chamber, each of said shafts carrying one of said jaws which consists of opposite end and side walls mounted upon a boss and a curved outer wall opposite to the boss, the opposite end portions of the curved outer wall of each said jaw overhanging the opposite end walls of the jaw so as to form lips which facilitate opening and closing of the inlet and outlet ports and also the discharge of the material from said spaces through the outlet ports.

9. A pump according to claim 1, wherein the pump chamber is provided with a pair of circumferentially spaced valveless inlet ports communicating by means of a passage with an inlet opening whilst a pair of circumferentially spaced valveless outlet ports communicate through a passage with an outlet opening, the pairs of inlet and outlet ports being substantially oppositely

disposed around the pump chamber so that separate inlet and outlet ports are provided for each of the spaces between the jaws.

10. A pump according to claim 1, wherein said jaws are mounted upon a pair of axially aligned shafts, one for each jaw, said jaw shafts being provided with a pair of crank arms connected by connecting rods with a pair of substantially oppositely disposed cranks on a driving shaft, the length of the driving cranks being less than that of the jaw cranks whereby rotation of the driving cranks imparts oscillation to the pump shafts and to the jaws carried thereby.

11. A pump according to claim 1, wherein the pump chamber is centrally located in the main casing and fitted with removable side plates each of which is provided with a bracket fitted with bearings for carrying one of a pair of axially aligned shafts one for each jaw, each said shaft being provided with a crank arm for oscillating its jaw, the crank arm on one of said shafts extending upwardly of its shaft whilst the other crank extends downwardly of its shaft.

12. A pump according to claim 1, wherein the pump chamber is fitted with removable side plates carrying a pair of axially aligned shafts, one for each jaw, said shafts being provided with sealing means for preventing the escape of liquid from the pump chamber, said sealing means comprising rings mounted one on each of said side plates so as to surround the associated shaft, the outer edge portion of each sealing ring being secured to its side plate while the inner edge portion of the ring is secured to its arcuate jaw in such a manner so as to permit the ring to flex during the oscillatory movements of its jaw without permitting bodily movement to occur between each sealing ring and its jaw and associated side plate.

DAVID WILLIAM BINGHAM.