

A. E. BURDIN,
 VENTILATOR,
 APPLICATION FILED OCT. 14, 1918.

1,298,171.

Patented Mar. 25, 1919.

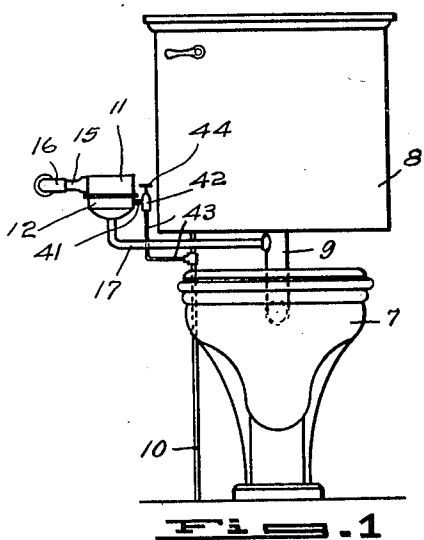

FIG. 1

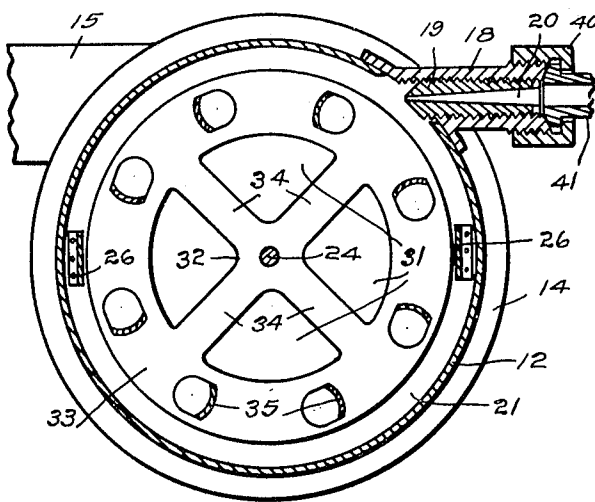

FIG. 4

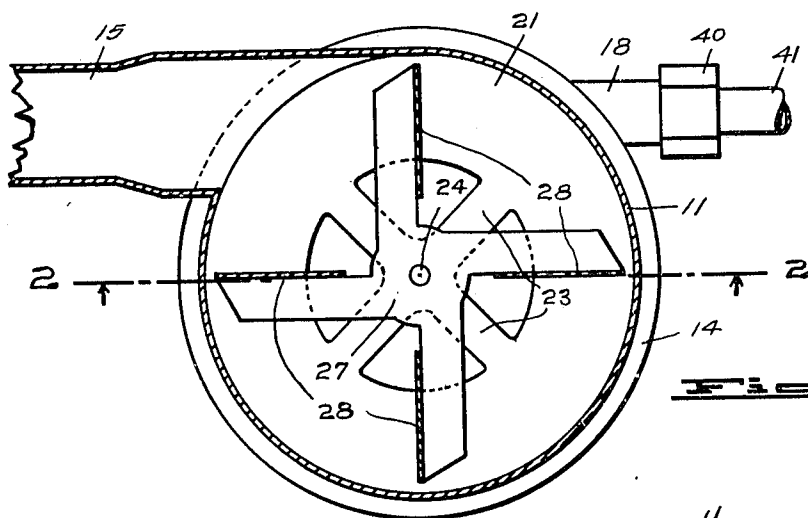

FIG. 3

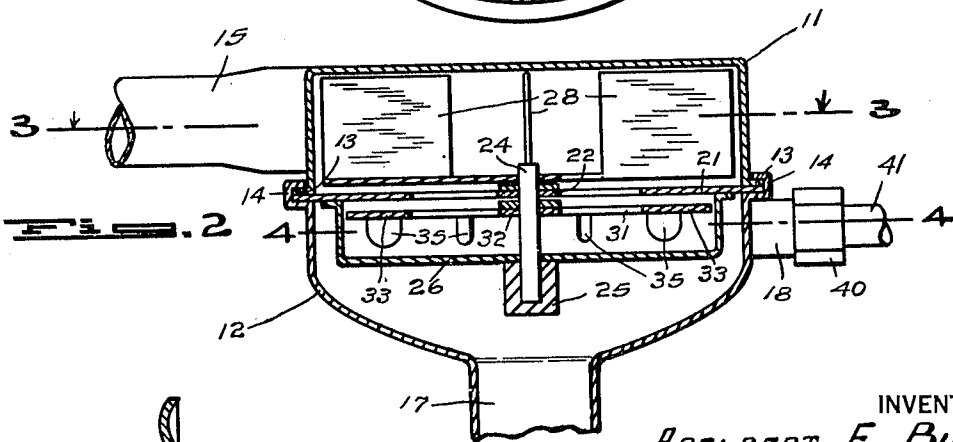

FIG. 2



FIG. 5

INVENTOR
ROBERT E. BURDIN
 BY
Frank Warren
 ATTORNEY

UNITED STATES PATENT OFFICE.

ADELBERT E. BURDIN, OF SEATTLE, WASHINGTON.

VENTILATOR.

1,298,171.

Specification of Letters Patent. Patented Mar. 25, 1919.

Application filed October 14, 1918. Serial No. 258,081.

To all whom it may concern:

Be it known that I, ADELBERT E. BURDIN, citizen of the United States, residing at Seattle, in the county of King and State of Washington, have invented a certain new and useful Improvement in Ventilators, of which the following is a specification.

My invention relates to improvements in ventilators for water-closet bowls and is in the nature of an improvement upon the device illustrated and described in my prior application Serial Number 151,126, filed February 26, 1917; and the object of my invention is to provide a ventilating device wherein the motor wheel and fan are disposed in the same casing, the casing being formed of two parts that are preferably stamped from sheet metal and are connected with each other by a water tight joint that permits the parts to be rotated relative to each other so that the water inlet and air outlet conduits may be turned at the most convenient angle when the device is installed.

My invention consists in the novel construction, adaptation and combination of parts as will be more clearly described and claimed.

I accomplish this object by devices illustrated in the accompanying drawings, wherein—

Figure 1 is a view in front elevation illustrating my invention as it may appear when installed upon a water-closet bowl;

Fig. 2 is a view in vertical mid-section substantially on a broken line 2, 2 of Fig. 3 of the casing including the motor wheel and fan;

Fig. 3 is a view in cross-section on broken line 3, 3 of Fig. 2;

Fig. 4 is a view in cross-section on broken line 4, 4 of Fig. 2; and

Fig. 5 is an enlarged fragmentary view in cross-section illustrating the form of construction of the water wheel.

Referring to the drawings, throughout which like reference numerals indicate like parts the numeral 7 designates a water-closet bowl of a well known form that may be connected with a flush tank 8 by a pipe 9 that enters the rear of the bowl in the usual manner as indicated by dotted lines in Fig. 1.

The flush tank 8 is connected in the usual manner with a water inlet pipe 10 that may

extend upwardly from the floor on which the bowl 7 is placed.

My invention contemplates a casing or housing formed of two parts 11 and 12 that are secured together, as shown in Fig. 2, by forming a relatively narrow annular outwardly directed flange 13 on the part 11 and a wider annular flange 14 on the part 12 and crimping the peripheral portion of the flange 14 over the flange 13 so that the two parts 11 and 12 of the housing are secured together by a water tight joint but may be rotated with respect to each other to facilitate the positioning of the air outlet and water inlet hereinafter described.

The upper section 11 of the casing is provided with a tangentially arranged air outlet 15 of relatively large size, as more clearly illustrated in Fig. 3, that is adapted to be connected with a pipe 16 that extends to a point outside of the building or to any suitable ventilating flue or passageway through which foul air and gases may be disposed.

The bottom end of the lower section 12 of the casing is rounded or bowl shape and is centrally connected with a pipe 17 of relatively large diameter that extends to and is connected with the pipe 9 that leads from the flush tank 8 to the bowl 7.

The lower casing section 12 is provided with a substantially tangentially arranged nipple 18 that is internally screw-threaded for the reception of an externally screw-threaded nozzle 19 that is provided with a converging water passageway 20.

The size of the passageway 20 will be determined by the water pressure under which it is to operate, it being the intention to provide a plurality of nozzles of the same external diameter and different internal diameters so that a nozzle of the correct size may be selected and inserted after the water pressure under which it is to operate has been determined.

The nipple 18 is connected by a coupling member 40 with a pipe 41 that is connected with a valve 42 and the valve 42 is connected by a pipe 43 with the water inlet pipe 10 as shown in Fig. 1 so that when the valve 42 is opened by turning a handle 44 water under pressure will be permitted to issue from the nozzle 19.

The mechanism within the casing comprises a disk 21 that is adapted to be firmly

held in place between the two parts 11 and 12 of the casing and is recessed adjacent its center to leave a hub portion 22 that is supported by integral spoke members 23.

5 Extending through the hub portion 22 is a stub shaft 24, the bottom end of which is journaled in a bearing lug 25 that may be brazed or soldered on to a bracket 26 that is secured to the disk 21 adjacent the periphery thereof.

10 Secured to the upper end of the shaft 24 and adapted to rotate within the upper section 11 of the casing is a fan member 27 that is preferably provided with four diametrically opposite blades 28 and is constructed of a single disk of metal as shown in Fig. 1, the blades 28 being stamped out and bent at right angles to the plane of the disk.

20 Secured to the shaft 24 below the disk 21 and adapted to rotate within the lower section 12 of the casing is a water wheel that is preferably formed of a single sheet of metal the body portion of which is cut away as at 31 around the center, to leave a hub member 32 that is connected with an outer annular rim 33 by integral spokes 34.

The buckets or vanes 35 of the wheel are formed by stamping out sections of the rim 33 at regular intervals and then bending these sections outwardly at right angles to the plane of the wheel and dishing them as shown in Fig. 5 to form cups in which the water may impinge.

35 The casing formed of the parts 11 and 12 may be installed in any convenient location it being possible to rotate the two parts 11 and 12 with respect to each other thereby bringing the air outlet 15 and the water inlet 18 into any desired relative position.

40 When the device is installed as herein described and the valve 42 is opened a stream of water under pressure will issue from the nozzle 19 and impinge against the cup-shaped vanes 35 of the water wheel thereby rotating the shaft 24 together with the fan 27 at high speed and causing the fan to draw air through the pipe 17 that connects with the bowl 7 and discharge such air through the outlet pipes 15 and 16.

50 After the water from the nozzle 19 has completed its work on the water wheel it will drop downwardly and flow by gravity through the pipes 17 and 9 into the bowl 7 where it helps the flushing of the bowl 7.

55 It will thus be seen that a single pipe is used for conducting the air and gases away from the bowl and conducting the used water from the motor to the bowl, the veloc-

ity of the air not being sufficient to cause the air to pick up the water or to seriously hinder the flow of the relatively small amount of water that is used by the water wheel.

Obviously changes in the form of construction and arrangement of parts of my invention may be resorted to within the scope of the following claims.

What I claim is:

1. In a device of the class described comprising a cylindrical housing formed of an upper section having an outwardly directed annular flange around its bottom edge and a lower section having an outwardly directed flange around its top edge, one of said flanges being wider than the other flange and being crimped over said outer flange to form a water tight connection that will permit a relative turning movement between said upper section and said lower section, a water inlet opening disposed within said lower section, and an air outlet opening disposed within said upper section, said turning movement permitting the water inlet opening and the air outlet opening to be turned to any desired angle.

2. In a device of the class described comprising a cylindrical housing formed of an upper section and a lower section so formed as to make a water tight connection that will permit a relative turning movement between said upper and said lower section, a circular plate supported between said upper and said lower section, said plate having a hub portion around which is provided passages, a shaft journaled in said hub portion, a bracket connected with the outer edges of said circular plate, a step bearing for said shaft, said step bearing being supported by said bracket in spaced relation from said plate, a water wheel secured to said shaft and adapted to rotate between said plate and said bracket, said water wheel being formed of a flat metal disk having openings around the center and vanes around the peripheral portion thereof, a fan secured to said shaft and disposed within the upper section, a nozzle adapted to direct a jet of water tangentially on to the vanes of said water wheel, a water inlet opening disposed within said lower section, an air outlet opening disposed within said upper section said turning movement permitting the water inlet opening and the air outlet opening to be turned to any desired angle.

In witness whereof, I hereunto subscribe my name this 5th day of October A. D. 1918.

ADELBERT E. BURDIN.