

Feb. 8, 1927.

1,616,640

F. H. SPRAGUE  
ADJUSTABLE CUFF FOR GARMENTS

Filed July 16, 1926

Fig. 1.

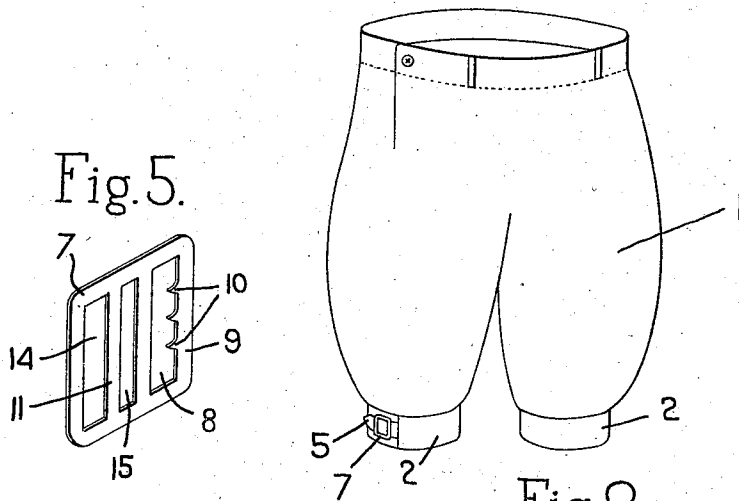

Fig. 5.

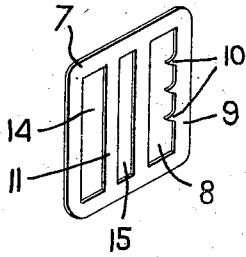

Fig. 2.

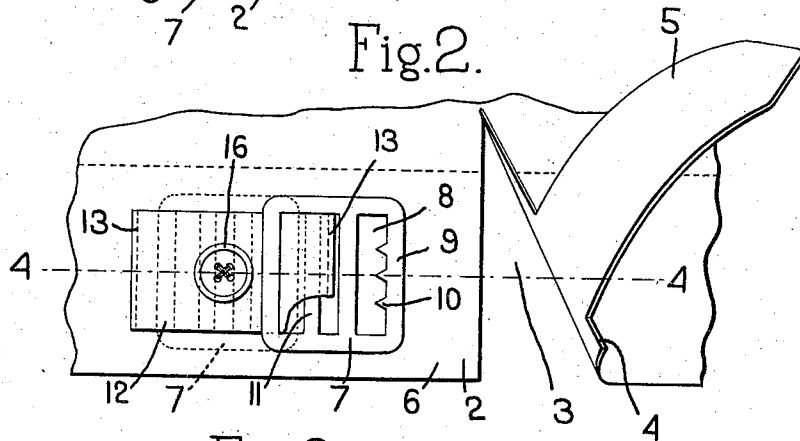

Fig. 3.

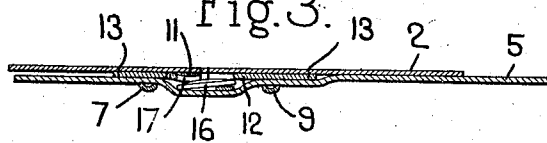
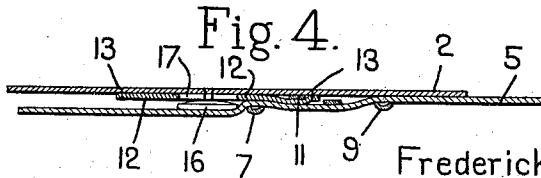

Fig. 4.



Inventor.  
Frederick H. Sprague  
by *Heard Smith & Tennant.*  
Attys.

# UNITED STATES PATENT OFFICE.

FREDERICK H. SPRAGUE, OF FITCHBURG, MASSACHUSETTS.

## ADJUSTABLE CUFF FOR GARMENTS.

Application filed July 16, 1926. Serial No. 122,796.

This invention relates to garments and particularly to a cuff construction and the object of the invention is to provide a novel form of adjustable cuff which may be used on the bottom of knickers and other similar locations. The improved cuff construction is of the familiar open type, it having a tab on one edge and a buckle on the other edge by which the two edges of the cuff may be buckled together. The buckle construction provides an amount of adjustment which is limited by the length of the tab.

It is an object of my improvement to provide an added adjustment without lengthening the tab and this is accomplished by a novel manner of securing the buckle to the cuff so that the position of the buckle can be shifted. The buckle is retained in place by means of a strip of cloth sewed at its ends to the cuff, the strip passing over one of the bars of the buckle, which will be referred to as the anchoring bar.

Means are provided whereby the strip may be fastened to the cuff intermediate of its ends. With this construction the buckle may be located with its anchoring bar against the end of the retaining strip or may be located in position with its anchoring bar in engagement with the intermediate fastening means. In this way an added adjustment is provided beyond that which the tab itself would afford.

The invention is specially desirable in connection with knickers. The ordinary buckle construction which is commonly used on the cuffs of knickers is not always adequate because even when adjusted as small as the tab will allow the cuff is sometimes too large for some persons. With my invention, however, if a person has slender legs added adjustment can be secured by shifting the position of the buckle.

In order to give an understanding of the invention I have illustrated in the drawings a selected embodiment thereof which will now be described after which the novel features will be pointed out in the appended claims.

Fig. 1 is a perspective view of a pair of knickers embodying my invention;

Fig. 2 is an enlarged fragmentary detail view showing the improved way of securing the buckle to the cuff;

Figs. 3 and 4 are sections on the line 4-4, Fig. 2; Fig. 3 showing the buckle in one ad-

justed position, and Fig. 4 showing it in another adjusted position;

Fig. 5 is a perspective view of the buckle.

In the drawings 1 indicates a pair of knickers which is provided at the bottom of its legs with the usual cuff portions 2, each cuff being divided as shown at 3. One edge 4 of the cuff is provided with the usual tab 5 and the other edge 6 carries a buckle 7 to receive the tab, this being the usual construction in knickers.

The buckle 7 is of the type having the usual tab-receiving opening 8 through which the tab 5 is inserted, the bar 9 of the buckle having the teeth 10 to grip the tab. The buckle is also provided with the usual anchoring bar 11 by which it is secured to the cuff.

In the construction herein shown the buckle is retained in position by means of a strap 12 which is sewed to the cuff at its two ends, as shown at 13, the strap passing through the opening 14 of the buckle and over the anchoring bar 11 and back through the opening 15. The strap is of some length and it is provided with means for detachably securing it to the cuff intermediate of its ends. One convenient way is to use a button for this purpose and I have shown herein such a button 16 which is sewed to the cuff and is adapted to be buttoned through a buttonhole 17 formed in the strap 12.

With this construction the buckle may be either located in the position shown in full lines Fig. 2 and in Fig. 4 with the anchoring bar 11 against the line of stitching at the end of the strap, or said buckle may be anchored in the dotted line position Fig. 2 and in the position shown in Fig. 3 by detaching the strap from the cuff at its mid portion (this being done by withdrawing the button through the buttonhole 17) and then shifting the buckle into the dotted line position with the anchoring bar 11 at the left of the button, after which the button may be reinserted in the buttonhole. The anchoring bar will then be anchored against the button and the buckle will be retained in its retracted position, shown in dotted lines Fig. 2.

By this means it is possible to give the buckle two different positions and thus the total amount which the cuff may be adjusted is the amount of adjustment afforded by the length of the tab 5 added to the amount which the buckle can be adjusted.

## I claim:

1. In a garment, the combination with a divided cuff portion presenting two edges to be fastened together, of a tab extending from one edge, a buckle-holding strap secured to the other edge, a buckle having a cross bar extending under the strap, and means for fastening the strap to the garment intermediate of its ends, whereby the buckle may be placed with its anchoring bar either at one end of the strap or in a position to engage the detachable fastening means.

2. In a garment, the combination with a divided cuff portion presenting two edges to

be fastened together, of a tab extending from one edge, a buckle-holding strap secured to the other edge, a buckle for engagement with the tab having a cross bar extending under the strap, said strap being provided intermediate of its ends with a buttonhole, and a button carried by the cuff portion and adapted to be entered through the buttonhole, whereby the buckle may be located either in a position at the end of the strap or in a position determined by the button.

In testimony whereof, I have signed my name to this specification.

FREDERICK H. SPRAGUE.