

No. 810,607.

PATENTED JAN. 23, 1906.

A. W. BANKS.  
HEATER.

APPLICATION FILED FEB. 29, 1904.

3 SHEETS—SHEET 1.

*Fig. 1.*

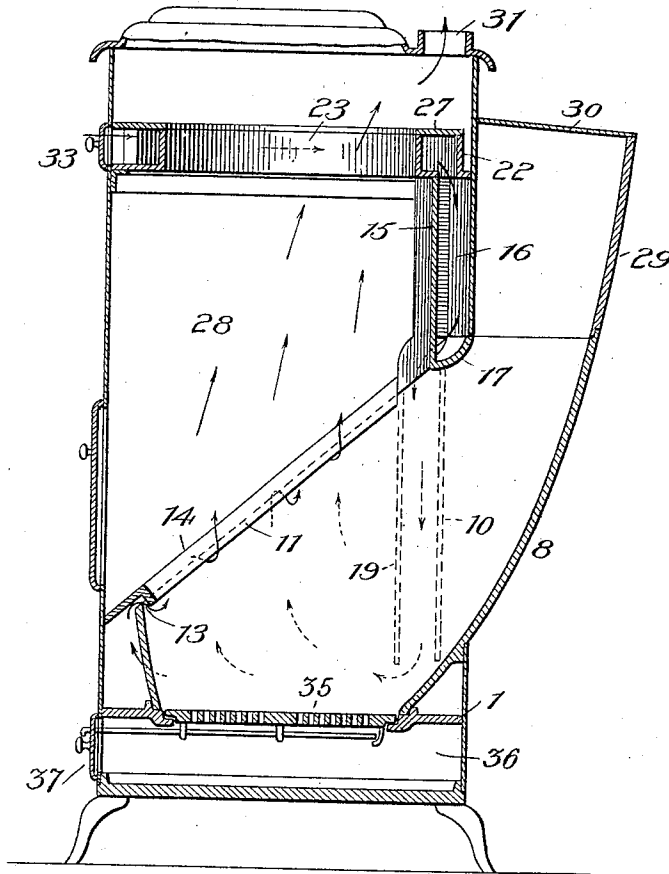

Witnesses  
*P. H. Burch*  
*Edwin L. Bradford*

Inventor  
*Archib W. Banks*  
By *A. O. Rebel*  
Attorney

A. W. BANKS.  
HEATER.

APPLICATION FILED FEB. 29, 1904.

3 SHEETS—SHEET 2.

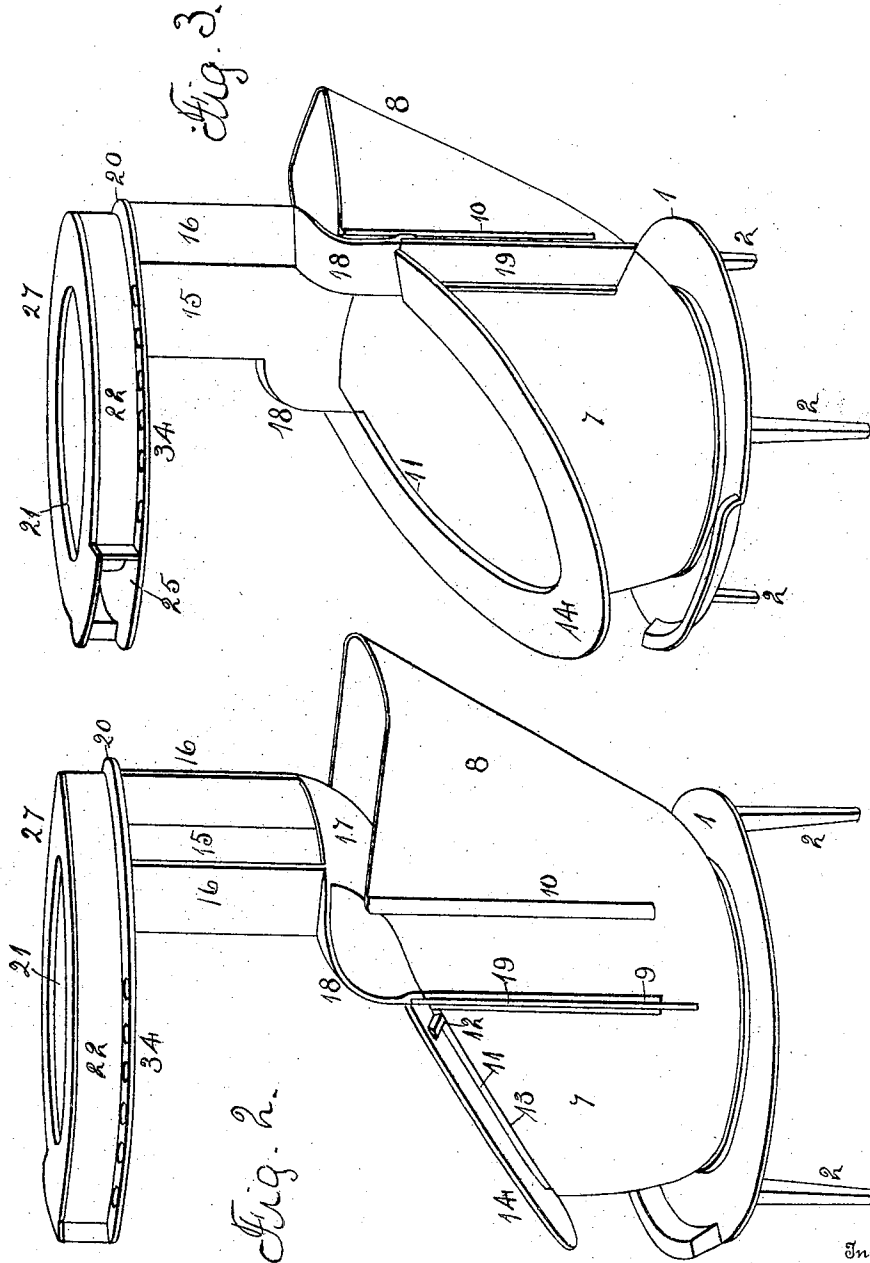

Fig. 2.

Fig. 3.

Witnesses

E. Behel.  
C. B. Clark

Inventor

Archib. W. Banks

By

a. behel

Attorney

No. 810,607.

PATENTED JAN. 23, 1906.

A. W. BANKS.  
HEATER.

APPLICATION FILED FEB. 29, 1904.

3 SHEETS—SHEET 3.

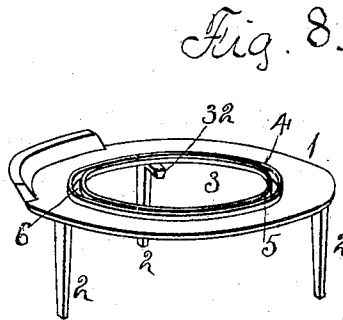
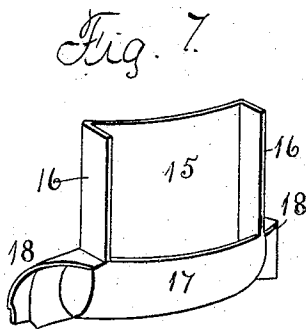
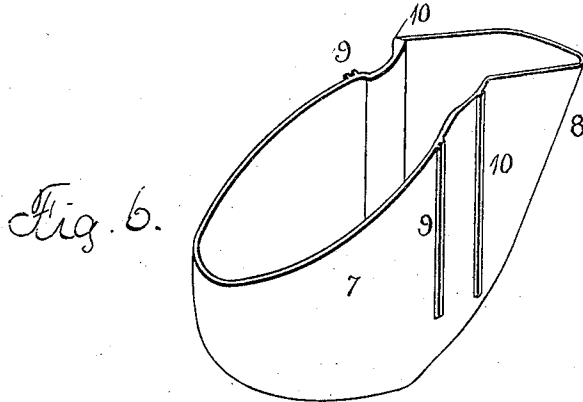
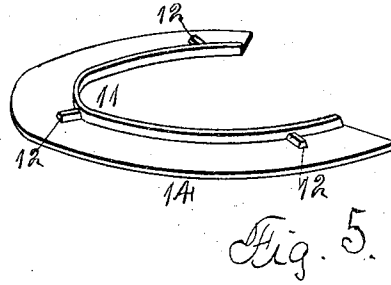
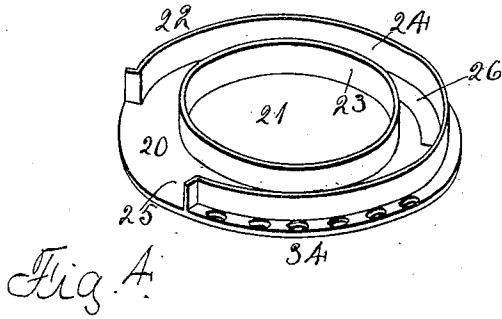

Witnesses

E. Behel.  
C. B. Clark

Inventor

Archib W. Banks.

By

a. behel.

Attorney

# UNITED STATES PATENT OFFICE.

ARCHIE W. BANKS, OF ROCKFORD, ILLINOIS, ASSIGNOR OF ONE-FIFTH  
TO MARTIN A. BANKS, OF ROCKFORD, ILLINOIS.

## HEATER.

No. 810,607.

Specification of Letters Patent.

Patented Jan. 23, 1906.

Application filed February 29, 1904. Serial No. 195,944.

*To all whom it may concern:*

Be it known that I, ARCHIE W. BANKS, a citizen of the United States, residing at Rockford, in the county of Winnebago and State of Illinois, have invented certain new and useful Improvements in Heaters, of which the following is a specification.

The object of this invention is to construct a soft-coal burner in which a fuel-magazine is employed and in which complete combustion takes place.

In the accompanying drawings, Figure 1 is a central vertical section from front to rear. Fig. 2 is a perspective view of the interior of the heater as seen from the rear. Fig. 3 is a similar view as seen from the front. Fig. 4 is a perspective view of the top plate. Fig. 5 is a perspective view of the bottom of the deflecting-plate. Fig. 6 is a perspective view of the fire-pot. Fig. 7 is a perspective view of the vertical air passage-way with its side outlets. Fig. 8 is a perspective view of the base-plate.

The base-plate 1 is supported upon legs 2 and in this instance is circular in form, having a central opening 3, around which rises two ribs 4 and 5, leaving a circular space between them.

A fire-pot (shown at Fig. 6) is seated between the ribs 4 and 5 of the base-plate and comprises the central section 7 and the rear extension 8. A grooved way 9 extends vertically along the outside of the center section at opposite sides and near the rear portion thereof, and a rib 10 extends vertically rearward of said grooved way. The front edge of the fire-pot is considerably lower than the rear edge.

A deflecting-plate 14 (shown at Fig. 5) is located over the upper edge of the fire-pot. The rim 11 depends within the fire-pot. The projections 12 rest upon the upper edge of the fire-pot, thereby holding the deflecting-plate clear of the fire-pot and leaving openings 13, forming a communication from the exterior of the fire-pot to the interior thereof. At the upper edge of the deflecting-plate and upon the fire-pot is located a chamber (shown at Fig. 7) and comprises the vertical inner wall 15, two side walls 16, a curved lower wall 17, and side wings 18. To each side wing is secured a plate 19, being located in the vertical grooved ways 9 and extending short of the lower end of the fire-pot.

Over the fire-pot is located a top plate (shown at Fig. 4) and comprising a circular plate 20, having a central opening 21, and two flanges 22 and 23, forming an annular space 24 between them. The flange 22 has a section cut away, leaving an opening 25, and the center plate 20 has a curved opening 26 diametrically opposite the cut-away portion of the flange 22. The top plate is so located with relation to the upper edge of the plate 15 that the opening 26 therein will coincide with the space bounded by the plates 15 and side walls 16.

Over the top plate is located a ring 27, thereby inclosing the space 24 between the flanges 22 and 23 and leaving a central opening coinciding with the central opening of the top plate.

The outer sheet-metal casing 28 incloses all the above-mentioned parts with the exception of that portion of the fuel-magazine extending rearward of the rib 10, the casing terminating at this point and secured to said ribs on each side of the fire-pot. The casing incloses the rear face of the air passage-way (shown at Fig. 2) composed of the plate 15 and end walls 16, also forms an air-space below the deflecting-plate and around the outside of the fire-pot. The fuel-magazine is continued upward by the extension 29, over which a cover 30 is placed. The flue 31 extends from the casing above the ring 27. A grate 35 will be supported by the projections 32, and that space below the base-plate forms an ash-chamber 36.

With a fire started in the fire-pot and soft coal in the fuel-magazine the direct draft will be through the grate and fire out by the flue 31. When fire is well under way, the damper 37, admitting air to the ash-pit, is necessarily closed, and the damper 33, admitting air to the annular space 24 in the top plate, is opened. The air thus admitted into the space 24 passes around between the rings 22 and 23, thence down the vertical passage-way and by the lateral openings into the spaces between the casing and plates 19, thence beneath the ends of the plates 19 into the space surrounding the fire-pot, thence through the openings 13 into the fire-pot above the fire, and finally passing out through the flue. The air thus taken in is gradually heated until it passes over the fire and is in the best condition possible to form complete

combustion. By forming the vertical air passage-way between the combustion-chamber and the fuel-magazine there is no danger of the fuel in the magazine taking fire. By forming the fire-pot tapering toward its front and locating the fuel-magazine at the rear the fuel will feed in and remain substantially parallel with the cut-away portion of the fire-pot, which allows the door communicating with the combustion-chamber to be lower than usual and the fire easily attended to through the opening.

The construction of stove will allow the new fuel to feed in from the back and will be burned away at the front, which will admit of a very small quantity of fresh fuel at any one time into the combustion-chamber. This construction subjects the fuel to substantially the same treatment as employed in chain-grate construction. The products of combustion in passing to the flue will pass through the openings 34 through the plate 20, also through the central opening 21, thereby imparting great heat to the air in the space 24. The rim 11, depending from the deflecting-plate 14, extends below the upper edge of the fire-pot, thus preventing ashes from falling over the upper edge of the fire-pot into the space outside thereof.

It is evident that my improvements may be applied to stoves, furnaces, and heaters of all kinds without departing from the scope of my invention.

I claim as my invention—

1. In a heater, an outer casing, a fire-pot located within the casing leaving an air-conduit around the fire-pot, a deflecting-plate located over the upper edge of the fire-pot leaving air-passages between the plate and

fire-pot, two vertical partitions at the sides of the fire-pot stopping short of the bottom of the fire-pot, and a vertical air passage-way at the back of the heater communicating with the conduit between the partitions.

2. In a heater, an outer casing, a fire-pot located within the casing leaving an air-conduit around the fire-pot, a deflecting-plate located over the upper edge of the fire-pot leaving air-passages between the plate and fire-pot, two vertical partitions at the sides of the fire-pot stopping short of the bottom of the fire-pot, a vertical air passage-way at the back of the heater communicating with the conduit between the partitions, and a top formed with an annular passage-way having a communication with the vertical passage-way and with the outer air.

3. In a heater, an outer casing, a fire-pot located within the casing leaving an air-conduit around the fire-pot, a deflecting-plate located over the upper edge of the fire-pot leaving air-passages between the plate and fire-pot, two vertical partitions at the sides of the fire-pot stopping short of the bottom of the fire-pot, a vertical air passage-way at the back of the heater communicating with the conduit between the partitions, and a top formed with an annular passage-way having a communication with the vertical passage-way and with the outer air, the fire-pot having a fuel-magazine at its rear and separated from the combustion-chamber by the vertical air passage-way.

ARCHIE W. BANKS.

Witnesses:

A. O. BEHEL,  
E. BEHEL.