

(19) **DANMARK**

(10) **DK/EP 2644960 T3**



(12) **Oversættelse af
europæisk patentskrift**

Patent- og
Varemærkestyrelsen

-
- (51) Int.Cl.: **F 16 L 51/02 (2006.01)** *F 16 L 25/01 (2006.01)*
- (45) Oversættelsen bekendtgjort den: **2017-07-17**
- (80) Dato for Den Europæiske Patentmyndigheds bekendtgørelse om meddelelse af patentet: **2017-04-19**
- (86) Europæisk ansøgning nr.: **13158718.0**
- (86) Europæisk indleveringsdag: **2013-03-12**
- (87) Den europæiske ansøgnings publiceringsdag: **2013-10-02**
- (30) Prioritet: **2012-03-26 DE 102012204800**
- (84) Designerede stater: **AL AT BE BG CH CY CZ DE DK EE ES FI FR GB GR HR HU IE IS IT LI LT LU LV MC MK MT NL NO PL PT RO RS SE SI SK SM TR**
- (73) Patenthaver: **Krones AG, Böhmerwaldstraße 5, 93073 Neutraubling, Tyskland**
- (72) Opfinder: **Wiedenmann, Willi, Böhmerwaldstrasse 5, 93073 Neutraubling, Tyskland**
Justl, Johann, Böhmerwaldstrasse 5, 93073 Neutraubling, Tyskland
Sauer, Martin, Böhmerwaldstrasse 5, 93073 Neutraubling, Tyskland
- (74) Fuldmægtig i Danmark: **Larsen & Birkeholm A/S Skandinavisk Patentbureau, Banegårdspladsen 1, 1570 København V, Danmark**
- (54) Benævnelse: **Kombination af to rør og en rørledningsforbinder med kompensator**
- (56) Fremdragne publikationer:
DE-A1- 2 738 231
DE-A1- 3 208 516
DE-A1- 10 259 213
FR-A1- 2 660 046
US-A- 1 726 483
US-A- 2 014 355
US-A- 2 650 111
US-B1- 6 234 542

EP 13 158 718.0

5 The present invention refers to a combination consisting of two pipes and a pipe connector with compensator.

10 Pipe connectors with compensator are used to compensate for a thermal change, particularly an expansion of pipes. Especially in the food industry or other applications where strongly heated articles are transported, thermal changes in the pipe length may otherwise lead to damage to the corresponding pipe systems. It is advantageous when such pipe connectors can be installed and removed as easily as possible because maintenance can thereby be facilitated.

15 DE 32 08 516 A discloses an arrangement for taking up longitudinal expansion and contraction in pipelines. US 2,014,355 discloses a vibration-isolating pipe connector comprising the features according to the preamble of claim 1. DE 27 38 231 shows a safety compensator with expansion element for pipelines. US 6,234,542 B1 shows a compensator for a pipe system, DE 102 59 213 A1 shows a length compensator for sub-soil electrical power cables. US 1,726,483 shows a compensator, and FR 2 660 046 also shows a compensator.

20 At the same time it is required in some fields, for instance in food processing, that a pipe connector should be easily cleanable. Preferably, the transition between pipe and pipe connector on the inside of the pipe should extend smoothly in axial direction, i.e. for instance without edges or offset. This can prevent a situation where regions that are difficult to wash, for instance corners and edges or recesses or offset, are created in the transition area.

25 This arrangement of the pipe connector with respect to the two pipes to be connected, in which the transition between pipe and pipe connector on the inside of the pipe extends each time smoothly in axial direction without offset of the components, is also called centred. A pipe connector in such a centred arrangement can also be described as centred. A centring by the attachment, e.g. flange connections, is often not adequate for centring because of play in radial direction. Therefore, this may lead to offset due to the screws and bores in the flanges. If the pipe connector is not centred, adequate cleaning by way of washing cannot be ensured. Therefore, it is particularly the food industry that requires a pipe connector which can be installed in centred fashion.

35

This problem is solved by a combination consisting of two pipes and a pipe connector according to claim 1 and a method for producing such a combination according to claim 13.

5 The pipe connector comprises a compensator for compensating for thermal change, particularly thermal expansion, and means for centring the pipe connector.

This centring operation can be carried out such that the inner edges of the pipe can each time be matched at the joint with the inner edge of the pipe connector, so that there is a smooth connection between two connected parts each time.

10

In the pipe connector the centring means comprise a centring sleeve (hereinafter also called sleeve). Such a sleeve can exert a uniform pressure and may therefore be advantageous, for instance in relation to a screw union by way of flange connections alone. This centring sleeve can extend in the mounted state over the whole length of the compensator. This can be
15 advantageous because a centring sleeve which in the mounted state extends over the whole length of the compensator can thereby for instance prevent an overexpansion of the compensator in radial direction.

Extending over the whole length of the compensator means in this connection that the length of
20 the sleeve in the mounted state in axial direction is longer than the length of the compensator in axial direction and upon viewing in a direction perpendicular to the axis of the pipe connector the length of the sleeve extends over the whole length of the compensator. Especially for instance upon viewing in a direction perpendicular to the pipe and pipe-connector axes from the outside it is then only possible to see the centring sleeve and not the compensator, except at the places
25 where the sleeve is interrupted, e.g. by one or several holes. Such a centring sleeve may be configured as one part. However, it may also be configured as two parts. Such a two-part sleeve can be advantageous as it can be mounted more easily than a one-part sleeve. For instance, the two parts can be joined by way of a clamp during assembly and can thereby be mounted. Specifically, such a two-part sleeve may comprise two parts of equal size that during assembly
30 are joined together in the centre, for instance by way of a clamp.

The sleeve may be configured to be continuous, i.e. for instance without interruptions, in a region where in the mounted state it surrounds the central portion of the compensator. Such a centring sleeve, however, may also be interrupted at some places. Specifically, such a centring
35 sleeve may be configured to be non-continuous in the centre. Such a centring sleeve may be

configured to be continuous for instance only after installation and joining together, for instance by way of a clamp.

Such pipe connectors with compensator may for instance be designed for a connection of pipes
5 with a nominal width having a value between DN 25 and DN 150.

The inner diameter of the sleeve may be configured such that it is only little more than the diameter of the pipe and the compensator ends, thus for instance the flanges. Specifically, the inner diameter of the sleeve can be greater than the diameter of the pipe and compensator
10 ends, e.g. by not more than 6 mm, particularly by not more than 5 mm or 4 mm or 3 mm or 2 mm, particularly by not more than 1 mm, particularly by not more than 0.1 mm.

After introduction or preliminary insertion of the compensator said centring sleeve or its parts can be slid over the compensator and at least a part of the pipes. The pipe connector is thereby
15 centred. Subsequently, for instance the pipe end can be detachably mounted with an end of the pipe connector in the centred position. This can for instance be accomplished by bolting flange connections.

In one embodiment of the invention the centring means may additionally comprise two guide
20 belts. These may for instance extend in the area where pipe and pipe connector meet each other over a respective part of the pipe and a part of the pipe connector. If the sleeve is now pulled over the pipe connector and the two, respectively adjoining regions of the pipes, for instance flanges, the inside of the sleeve will uniformly press against the respective guide belts, which has the effect that the pipe connector is centred. For instance, a guide belt can
25 respectively extend in part over a flange connected to a pipe (flange of a pipe) and partly over a flange connected to the compensator (flange of the compensator) if the connection between compensator and pipe is established by flanges.

Preferably, the two guide belts consist of a non-elastic material, for instance a metal or (hard)
30 plastic, such as PTFE. Specifically, they may be configured such that in the mounted state they project slightly beyond the connections between a respective pipe and the pipe connector, thus for instance the respective flanges, radially to the outside. Thus the centring can only be carried out by way of the pressure acting on the guide belts.

In some embodiments such guide belts may e.g. be configured such that they project each time more than 0.1 mm or more than 2 mm or more than 3 mm beyond the diameter of the respective flanges if they are mounted in the centred position.

- 5 Such guide belts may particularly be configured as broad guide belts; this means that their width (along the axial direction) is greater than the height (measured along the radial direction). For instance, the width can be more than the onefold or more than the twofold or more than the fourfold height. Height and width can be measured in the state in which the pipe connector is mounted to connect the pipes (mounted state).

10

In the pipe connector the centring sleeve can be mounted by way of two or four mounting aids. Such mounting aids may e.g. be designed as snap rings which may optionally have a round cross-section. To this end two holes may be provided in the sleeve for introducing the mounting aid(s). During this introduction a mounting aid can be passed through a hole from the outside
15 through the sleeve and then be guided along the sleeve at the side facing the compensator and the pipes. The guidance along the sleeve can here particularly be carried out in a direction perpendicular to the axis of the two pipes and the sleeve axis. Specifically, the guidance along the sleeve can be performed by way of a hollow in the sleeve. In the area of said hollow the sleeve is thinner than in the other areas. The direction in which the mounting aid is introduced
20 through a hole can thereby be predetermined. Specifically, this can be accomplished in that there is only enough space in the area of said hollows for the introduction of mounting aids underneath the sleeve.

These two holes and optionally the hollows may for instance be provided in regions which come
25 to rest in the mounted state above the pipe ends and/or the compensator ends. Such pipe and/or compensator ends may for instance comprise a respective flange.

A mounting aid which preferably has a round cross-section can then be introduced through said two holes. By way of hollows in the sleeve and/or the pipe and/or compensator ends, such as for
30 instance the flanges, the direction in which the mounting aid is introduced can then be defined. The mounting aid or the mounting aids can extend in the mounted state along the inner radius of the centring sleeve, namely for instance at least in an angular range of 180° or at least in an angular range of 270° or at least in an angular range of 315° or at least in an angular range of 345° along the radius.

35

In addition a device may comprise two further mounting aids or may be configured for the installation of two further mounting aids. Further recesses may e.g. be provided for these aids. Such recesses may particularly be provided such that they are not located or are only partly located underneath the sleeve. The two further mounting aids may extend in an angular range of
5 at least 180°, particularly at least 270°, particularly at least 315°, particularly 345° along the radius of the pipe or compensator end, e.g. a flange.

The possibility of movement of the mounting aids introduced through holes in the sleeve and/or of the optional, additional mounting sleeves may be limited in the axial direction, for instance by
10 the fact that there are provided corresponding recesses in or steps on the respective flanges and/or hollows in the sleeve that limit the possibility of movement. The possibility of movement of the compensator in axial direction can also be limited. For instance, due to the possibility of movement of the mounting aid it is possible to simultaneously define the distance by which the compensator can move. This can for instance prevent an excessive expansion of the
15 compensator and an excessive compression of the compensator, of which both may induce damage to the compensator. Alternatively, a first mounting aid can limit expansion and a second mounting aid can limit compression. Specifically, the first mounting aid introduced through a hole into the sleeve can limit the possible expansion of the compensator in axial direction while the optionally existing, additional mounting aid limits the possible compression of the compensator,
20 or vice versa.

The pipe connector may be configured such that the pipe connector or parts thereof can be installed and removed and/or exchanged from the side without an axial movement of the pipes which get connected. For instance, it may be necessary to replace the compensator or optionally
25 existing seals more often than the centring sleeve.

Optionally, flanges can be welded (for instance before or during a first installation of a pipe connector) into the pipeline system, particularly on the two pipes to be connected. Such flanges can for instance be welded in by way of a weld-in device with an exact bore position and
30 distance.

During installation of a pipe connector the centring sleeve can first be pulled over one of the two pipes that are to be interconnected. In the case of a sleeve of a two-part type a sleeve part may for instance also be pulled over each of the pipes to be connected. The pipe connector can then
35 be introduced, e.g. slid, loosely between the two pipes, guide belts can optionally be mounted,

and the centring sleeve can be pulled over the compensator and the pipe ends and/or connecting means, particularly flanges of the pipes to be connected and the optionally existing guide belts. In the case of sleeves of a one-part or two-part configuration, one or two earthing devices, such as springs, may be mounted optionally before the pulling of the sleeves or sleeve parts over the compensator, so that the sleeve or each sleeve part is earthed individually. The part or parts of the earthing device may be configured such that they exert pressure on the sleeve, so that a stable contact can be maintained.

In two-part sleeves the two sleeve parts can subsequently also be pulled over the compensator, the pipe ends and/or connecting means, particularly for instance flanges, of the pipes to be connected and the optionally existing guide belts such that they come together at a joint. Subsequently, the two sleeve parts, for instance sleeve halves, can be mounted on and/or connected to each other. Such a mounting can for instance be carried out by way of a clamp. By way of an optional introduction of one or two mounting aids through holes existing in the centring sleeve, the centring sleeve can be fastened and the movement of the sleeve in axial direction can be limited. For instance, by way of the two introduced mounting aids the movement of the sleeve in axial direction can be limited such that possible compression and/or possible expansion of the compensator are thereby also limited at the same time. Subsequently, the pipe connector centred in this way can be detachably mounted in the centred position, for instance by screwing flange connections in the centred position.

Subsequently, two additional mounting aids can optionally be installed. Such additional mounting aids, in addition to the two, already optionally existing mounting aids, may be of advantage if only one compensator movement in one direction is limited by the already optionally existing mounting aids. For instance only the expansion or compression of the compensator can be limited by the already existing mounting aids. The compression or expansion could then respectively be limited by the additional mounting aids. The compensator can then be secured against excessive expansion and excessive compression.

For the removal of the respective pipe connector the steps can e.g. be carried out in reverse order. Alternatively, also after removal of the one or two mounting aids it is first the sleeve and then the flange connection that can be detached and the compensator can be removed in this way. In a last step the sleeve, if it is to be replaced, can then also be removed.

Each of the above-described steps can be performed from the side of the pipes without the need for an axial movement of the pipes away from or towards each other. This can facilitate the installation and removal of the pipe connector and its maintenance.

- 5 According to the invention the pipe connector at the two compensator ends with which the pipe connector abuts on the pipes comprises a respective flange. The two pipes to be connected are also provided at the pipe ends with flanges which can then for instance be screwed with a respective flange to the compensator end.
- 10 Optionally, one or both of the two flanges of the compensator may be stepped at one side. This can for instance be advantageous because a raised edge resulting from the step can for instance serve to prevent the movement of a guide belt in one direction. Moreover, such an edge can act as a movement restriction of a mounting aid. Alternatively or in addition, one or both of the flanges of the pipe connector may comprise a recess, for instance for accommodating the
- 15 mounting aid(s). By way of the edges on the sides of the recesses and/or of one or several steps the movement possibility of mounting aid(s) and/or guide belts can e.g. be restricted each time.

According to the invention the pipe connector connects two pipes, each having a flange of the same diameter. (The maximum diameter of the flange which e.g. in the mounted state can be

20 measured in a direction perpendicular to the axis of the pipe connector is called diameter in this text). Optionally, a pipe connector according to the invention may also comprise these two flanges of the respective pipes with which it can be connected. Such a pipe connector may e.g. be supplied already with fitting flanges that could then be welded to the pipe ends of the pipes to be connected. Welding can e.g. be carried out by way of weld-in devices with exact bore position

25 and distance.

In some embodiments the flanges on the compensators have the same diameter as the flanges of the pipes with which it can be connected.

- 30 One or both of the flanges of the two pipes to be connected may comprise a recess, e.g. for accommodating the mounting aid(s), and/or may be stepped at one side. Owing to the edges at the sides of the recesses or at the side of the steps the movements of e.g. mounting aids and/or guide belts can be restricted each time.

Preferably, the two edges of flanges in the area where the flanges meet in the centred state are positioned at the same level.

5 For example, a step of the flange in the case of a pipe to be connected may be located at the same depth as the step of one or of the flanges at or on the compensator end(s). If this is the case with flanges of the same diameter, the two edges positioned on the outer edge of the flanges may be located at the same level if they are centred.

10 In the case of flanges having different diameters, it may alternatively also be advantageous if in the case of two flanges to be mounted on one another, the one comprises a step and the other comprises a step with a different depth, so that the heights measured from the centre of the cross section are equal in radial direction. This may also have the effect that the edges located on the outer edge of the flanges are positioned on two meeting flanges at the same level if they are centred.

15

According to the invention the pipe connector comprises seals that after the mounting of the device respectively seal between a pipe and the device.

20 According to the invention these seals can be replaced individually. This can be of advantage because not every seal wear requires a complete exchange of the whole pipe connector or compensator. Preferably, such seals can be made from an elastomer, such as for instance EPDM, HNBR, FKM, or the like. Such seals can be replaced very advantageously. For instance, seals of materials based on PEEK or PTFE can be used. Costs and efforts can be reduced by way of individually replaceable seals. According to the invention the seals are configured such
25 that in the mounted state they are held at their position due to their shape, e.g. by way of a bulge in a flange or the like. According to the invention the seals are arranged such that they extend on the inner edge of the pipe also in axial direction smoothly, i.e. without offset and edges, with the edges of pipe connector and pipe.

30 In some embodiments a compensator comprises a bellows. For instance, a compensator may comprise a bellows in which the valleys have a cylindrical cross-section and/or in which the ratio of the radial depth to an axial width of the folds is about 1 or more, whereby the bellows can be washed more easily.

Such a bellows can particularly be made from a durable and/or easily washable material, such as metal. For instance, it can thereby be prevented that the bellows itself is easily vulnerable by aggressive cleaning agents or by goods guided through the pipes.

- 5 Furthermore, the invention comprises a valve manifold and/or a pipe system which comprises one, two, three or more of the previously described pipe connectors.

Furthermore, the invention comprises a method for producing a combination as described above with the steps previously described in connection with the installation of the pipe connector.

10

Further embodiments of the invention will be described with reference to the drawings. In the drawings,

Fig. 1a, b show pipe connectors;

- 15 Figs. 2a-2b show possible embodiments of a part of a pipe connector;

Figs. 3a-3b are views of mounted pipe connectors;

Fig. 4 shows a pipe system and/or valve manifold.

- 20 Fig. 1a shows a pipe connector 1 which comprises a compensator 2, a mounting aid 6 and means for centring the compensator. In the example shown in Fig. 1a, the centring means comprise a centring sleeve 4 as well as guide belts 5.

In the bottom half of the view shown in Fig. 1a, a (mounted) centring sleeve is visible from the outside; in the upper half a cross section through the axis of the pipe connector is visible.

25

- Furthermore, the pipe connector comprises flanges 7 at the two ends of the compensator. The pipe connector is connected by flanges 8 to two pipes and comprises the flanges 8. For instance by screwing flange connections with screws 9, the pipe connector can be detachably mounted on the pipes. As shown in Fig. 1, the compensator also comprises seals 10 which in the mounted state act as seals and can prevent liquid or transport material from exiting out of the pipe. Specifically, a seal is configured such that it can be replaced individually.
- 30

- Various embodiments of the area where the centring sleeve rests on the two connected ends of compensator and pipe, which area is designated as B in Fig. 1a and b, are shown in Fig. 2a to 2e. The embodiments shown in Fig. 2a to 2e are here shown as alternatives, but may also be
- 35

combined. For instance, an embodiment may be arranged at the one side of a pipe connector, another embodiment of area B may be arranged at the other side of the pipe connector.

5 A pipe connector, as is e.g. shown in Fig. 1a, may e.g. be installed in the following way: The centring sleeve 4 can be pulled over a pipe to be connected. Since it can be shifted particularly along the pipe, the pipe connector 1 can subsequently be introduced between the two pipes. Optionally, the guide belts 5 can be mounted at their position. This can e.g. be accomplished in that they are mounted from the side. Subsequently, the centring sleeve 4 can be pulled over the compensator 2 and the pipe ends, which are formed as flanges 8. By the pressure exerted by
10 the centring sleeve 4 on the guide belts 5 the compensator and/or the pipe connector can thereby be centred. Subsequently, the two mounting aids 6 in this example can be introduced through two holes existing in the sleeve 4, so that they come to rest in the hollows 11 in the sleeve. Moreover, the pipe connector 1 can be detachably mounted in the centred position on the two pipe ends. Specifically, this can for instance be done by screwing flanges, wherein
15 particularly a respective flange at a pipe end can be screwed to a flange at the compensator. Alternatively, the detachable mounting of the pipe connector 1 can also be carried out before the introduction of the mounting aids 6.

20 In other examples the step of installing guide belts and/or of introducing two mounting aids through holes can be omitted or in addition to the two mounting aids two further mounting aids can be installed.

Fig. 1b shows a different embodiment of a pipe connector. The components 2, 4, 5, 7, 8, 9, 10 shown in Fig. 1b correspond to the components shown in Fig. 1a. Differences with respect to
25 Fig. 1a are for instance that the sleeve 4 in the example shown in Fig. 1b is a two-part structure. It is fixed in the illustrated example by the clamp 17 such that in the fastened position it shows the same functionality as sleeve 4 of Fig. 1a. Furthermore, the device shown in Fig. 1b differs from the device of Fig. 1a in area B, which is shown in detail in Fig. 2e. However, other embodiments of the area B can also be used in the device shown in Fig. 1b, for instance the
30 embodiments shown in Figs. 2a to 2d.

In the case of a two-part sleeve the additional step of joining the sleeve parts and of connecting the sleeve parts, e.g. by way of a clamp 17, is normally taken during the installation of the pipe connector. Optionally, one or more earthing devices 18 may also be mounted during installation
35 of a pipe connector with a one-part or two-part sleeve.

A part of the centring sleeve 4 shown in cross section can be seen in Fig. 2a. As shown in this example, said sleeve may comprise a hollow 11 into which a mounting aid 6, e.g. with circular cross-section, can be introduced. Preferably, the mounting aid, for instance a snap ring, can rotate in the hollow 11, but preferably the mounting aid 6 in the embodiment shown in Fig. 2a cannot move such that its cross section is axially displaced with respect to the centring sleeve 4.

In Fig. 2a a part of the bellows 12, a flange 7, which is mounted at a side of the compensator, a flange 8 which is connected to a pipe, a screw 9 with which the two flanges are screwed together, a guide belt 5, a step 14 in the flange 7, and a step 15 in the flange 8 are also visible. The two steps 14 and 15 are jointly positioned in this illustrated example at the same depth and jointly form a recess which has such a width that the edges of the recess fix the guide belt at a position. Alternatively, the two steps may also have a different depth or one step may have such a depth that in the centred position it ends flush with the edge of the second flange, for instance when the flanges have different diameters (not shown here). In this case the two steps or the one step or the one diameter may also be configured such that their edges come to rest at the meeting area at the same level.

As shown in Fig. 2a, the guide belt may be configured such that it projects slightly beyond the outer radius of the flange, so that the force transmission from the centring sleeve to the two flanges takes place only via the guide belt 5.

What is also visible in the flange 8 is a recess 16 which is suited for accommodating the mounting aid 6. Within said recess 16 the mounting aid 6 can move in axial direction. Due to the dimensions of the recess 16 the maximal and minimal expansion of the compensator 2 is defined at the same time. In some embodiments of the invention a compensation path of 6 mm may for instance be defined. In some embodiments, for instance in a hollow 16, the mounting aid 6 may move each time by 3 mm or less than 3 mm or more than 3 mm or about 6 mm, more than 6 mm or less than 6 mm.

The seal 10 which is shown in cross section is replaceable individually. A compensator which can e.g. be designed as a bellows 12 or may comprise a bellows 12 is preferably produced from a durable material, such as for instance metal or the like. It can thereby be cleaned easily or is attacked less strongly for instance by aggressive cleaning agents. Thus the most wear-prone part of the pipe connector 1 may be the seal 10 which, however, can be replaced individually.

35

Fig. 2b shows an arrangement in which both flange 7 and flange 8 have steps. The step 15 of flange 8 ends in the centred position flush with the step 14 of flange 7. The movement possibility of the guide belt 5 can be restricted in axial direction at the one side by the edge of the step 14. At the other side the movement possibility of the guide belt is restricted in that the mounting aid 6 is present. The guide belt can therefore not move in axial direction further than up to the mounting aid 6. Preferably, in such an embodiment the movement possibility of the mounting aid 6 is limited by an edge of the step 15. Additionally, the dimensions of the recess formed by the two steps 14, 15 are preferably such that the guide belt 5 cannot fully slip onto the flange 8 at the same time, but a force for centring is always exerted on both flange 7 and flange 8.

10

The further features of the area shown in Fig. 2b can for instance correspond to the features shown in Fig. 2a.

Fig. 2c, in turn, shows a further arrangement in which the flange 7 comprises a step 14 and the flange 8 a step 15 and the guide belt 5 is held in its position against slippage in axial direction by the edges of the two steps. In contrast for instance to the above-discussed examples, a recess 16 is however provided in this case in flange 8 in such a manner that it exactly accommodates the mounting aid 6 and although the mounting aid 6 can rotate in the recess, the cross section of the mounting aid 6 is not movable in axial direction relative to the flange 8. A movement of the centring sleeve is allowed in the example shown in Fig. 2c by way of the hollow 11 provided in the centring sleeve, which permits a movement within the limits set to the mounting aid and thus to the centring sleeve in axial direction. In the example shown in Fig. 2c, the axial possible movements of the sleeve are defined by the expansion of the hollow 11 in the sleeve 4.

20

25

In other embodiments (not shown), it is also possible that hollows in the centring sleeve and/or the flanges respectively permit a certain movement of the mounting aid in axial direction. In this case the compensation path can be defined by the two possible movements defined by the hollows.

30

Fig. 2b, in turn, shows a further possible embodiment in which flange 8 comprises a step 15, and flange 7 also comprises a step 14. The edges of the steps 14 of the flange end, upon centring of the pipe connector, flush with the edges of the step 15 of flange 8. Centring is again carried out by way of a guide belt 5, the fixation of the guide belt 5 is performed at the one side by the edge created by the step 15 and at the other side by the mounting aid 6. Like in Fig. 2b, the dimensions of the centring sleeve and the positions of the hollows 11 can be chosen such that

35

the guide belt 5 always comes to rest on the two flanges and the guide aid 6 cannot slip from the flange 7 at the same time, for instance because of the edge of the step 14 of flange 7.

5 Fig. 2e shows a further embodiment. In this embodiment, a sleeve 4, a guide belt 5, flanges 7 and 8, screws 9 and a compensator, which may e.g. be designed as a bellows 12 or may comprise a bellows 12, can be seen again. In terms of their function these can correspond for instance to the components with the same names, as shown in Figs. 2a to 2d.

10 In Fig. 2e the guide belt 5 is also positioned in a recess which is formed by the two steps 14 and 15 of flanges 7 and 8. The movement of the guide belt is thus limited in axial direction or is not possible.

In the embodiment shown in Fig. 2e, two mounting aids 6a and 6b are present in area B. Hence, on the whole, a device which comprises two parts shown in the example shown in Fig. 2e can
15 thus be mounted by four mounting aids if it has a symmetrical structure. The mounting aid 6a is located in a recess 16a in the flange 8. The recess 11a in the sleeve allows a movement of the sleeve relative to the axis of the mounting aid 6a. By the hollow 11a, however, it is only the maximal expansion that is restricted and can be achieved by the compensator, and not the
20 compression.

The mounting aid 6b is in the illustrated example not underneath the sleeve and only moves partly underneath the sleeve 4 even in case of maximum compression. The hollow 11b in the sleeve 4 acts as a stop in case of compression, thereby preventing a further compression of the compensator. The mounting aid 6b is positioned in recess 16b in flange 8. In the illustrated
25 example the mounting aids 6a and 6b thus jointly define both the expansion and the compression of the compensator, so that these are not possible beyond a degree acceptable for the compensator.

30 Furthermore, an additional earthing device 18 which can e.g. be detachably mounted by way of screws on the flange 7 is visible in Fig. 2e. This device may be configured to exert pressure radially outwards on the sleeve and thereby to earth the two sleeve parts. This may be advantageous for applications of the pipe connector in explosion-prone areas because the sleeve may otherwise get statically charged, for instance when the guide belts are non-conductive.

35

The earthing device shown in Fig. 2e may e.g. be in the form of a (conductive) spring. Normally, (at least) one earthing device exists per sleeve part. Such earthing devices may also be present on the embodiments shown in Figs. 2a to 2d.

5 Figs. 3a and 3b show external views of a pipe connector. In Fig. 3a, a screwed pipe connector 1 with a one-part sleeve is visible from the outside. From the outside only one sleeve is visible and also the screwings and the flanges as well as the pipes that are connected.

10 Fig. 3b shows a view onto the screwings in the direction of the pipes. The flanges can e.g. be screwed with four M8 x 25 screws.

Figs. 3c and 3b show external views of a pipe connector in which the sleeve 4 is made of two parts. Visible is e.g. in Fig. 3c the sleeve 4 which is connected by way of a clamp 17 or a similar auxiliary means in the centre. Like in devices with sleeves of a one-part structure, the connection
15 may also be detachable in this example, for instance via screws 9.

Fig. 3d is a view onto the screwing in the direction of the pipes. In addition, one can see the clamp 17 as an example of a possible interconnection of the two sleeve parts.

20 Fig. 4 shows an example of a pipe system and/or valve manifold comprising one or more of the previously described pipe connectors. Such valve manifolds and/or pipe systems can e.g. be used in food technology. In this case heat expansion compensators are needed because heated goods can be transported. Upon expansion of the pipes, damage may already arise even in the case of relatively small expansions if a pipe system is operated without such pipe connectors
25 with compensator.

PATENTKRAV

1. Kombination af to rør og en rørledningsforbinder, hvor rørledningsforbinderen (1) omfatter en kompensator (2) og organer til centrering af rørledningsforbinderen (1), hvor
5 organerne til centrering af rørledningsforbinderen (1) omfatter en centreringsmuffe (4), der i fastgjort tilstand, hvor rørledningsforbinderen er fastgjort for at forbinde rørene, strækker sig over kompensatorens samlede længde, hvor kompensatorenderne hver især omfatter en flange (7),
10 hvor rørledningsforbinderen forbinder de to rør, der hver især udviser flanger (8) med samme diameter,
og hvor rørledningsforbinderen (1) omfatter tætninger (10), der efter fastgørelsen af rørledningsforbinderen (1) hver især tætner mellem en af rørflangerne (8) og den tilhørende flange (7) på kompensatorenden, **kendetegnet ved, at** tætningerne (10) kan udskiftes enkeltvis og er udformet således, at de i fastgjort tilstand på grund af deres form holdes
15 på deres position og er anbragt således, at de ved rørinkanten i aksial retning forløber plant med kanten af rørledningsforbinder og rør.
2. Kombination ifølge krav 1, **kendetegnet ved, at** rørledningsforbinderen (1) kan fastgøres aftageligt efter centreringen.
20
3. Kombination ifølge et af kravene 1-2, **kendetegnet ved, at** organerne til centrering omfatter to styrebånd (5).
4. Kombination ifølge et af kravene 1-3, **kendetegnet ved, at** centreringsmuffen (4) kan fastgøres med et eller to fastgørelseshjælpemidler (6), såsom for eksempel låseringe.
25
5. Kombination ifølge et af kravene 1-4, **kendetegnet ved, at** bevægelsesmuligheden for fastgørelseshjælpemidlerne (6) og/eller kompensatoren (2) er begrænset i aksial retning.
30
6. Kombination ifølge et af kravene 1-5, **kendetegnet ved, at** rørledningsforbinderen (1) og/eller dele deraf kan udskiftes fra siden uden en bevægelse af rørene i aksial retning.

7. Kombination ifølge et af kravene 1-6, hvor en eller begge flanger (1) valgfrit er aftrappet på en side og/eller omfatter en fordybning.

5 8. Kombination ifølge krav 1, **kendetegnet ved, at** dens flanger (7) har samme diameter som rørenes flanger (8).

10 9. Kombination ifølge et af kravene 1-8, **kendetegnet ved, at** en eller begge flanger (8) på de to rør, der skal forbindes, omfatter en eller hver især en fordybning (16) til at optage fastgørelshjælpemidlet eller fastgørelsesmidlerne (6), og/eller en eller begge flanger (8) er aftrappet på en side.

10. Kombination ifølge et af kravene 1-9, **kendetegnet ved, at** kompensatoren (2) omfatter en harmonikabælg.

15 11. Kombination ifølge et af kravene 1-10, **kendetegnet ved, at** muffen (4) er udformet todelt.

20 12. Ventilkryds og/eller rørsystem, **kendetegnet ved, at** det omfatter en, to, tre eller flere af kombinationerne ifølge et af kravene 1 til 11.

13. Fremgangsmåde til fremstilling af kombinationen ifølge et af kravene 1 til 11, **kendetegnet ved, at** den omfatter følgende trin:

25 at trække centreringsmuffen eller dennes dele over et af de to rør, der skal forbindes;

at indføre rørledningsforbinderen mellem de to rør;

valgfrit at anbringe styrebånd;

at trække centreringsmuffen over kompensatoren og rørenderne;

30 valgfrit at indføre to fastgørelshjælpemidler gennem to i centreringsmuffen forekommende huller;

valgfrit at anbringe to yderligere fastgørelshjælpemidler,

aftageligt at fastgøre rørledningsforbinderen i den centrerede position.

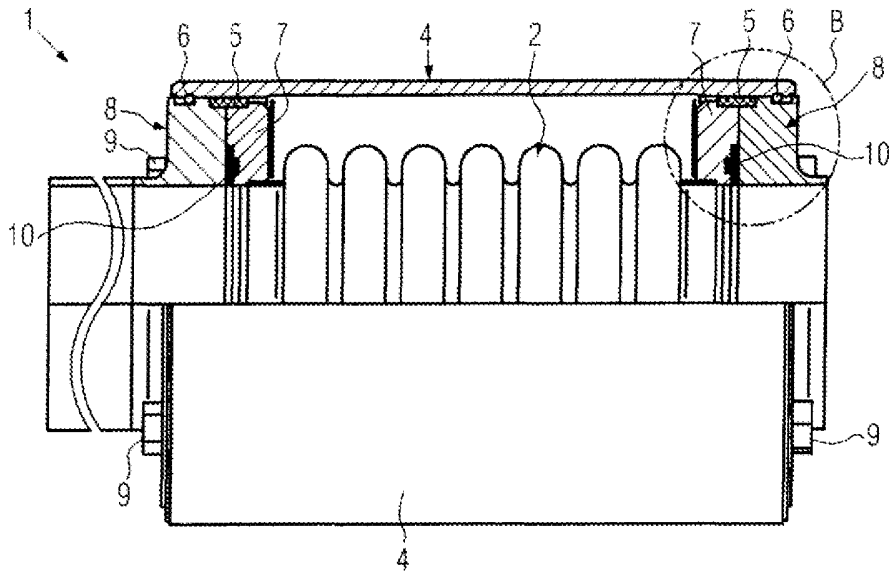

FIG. 1a

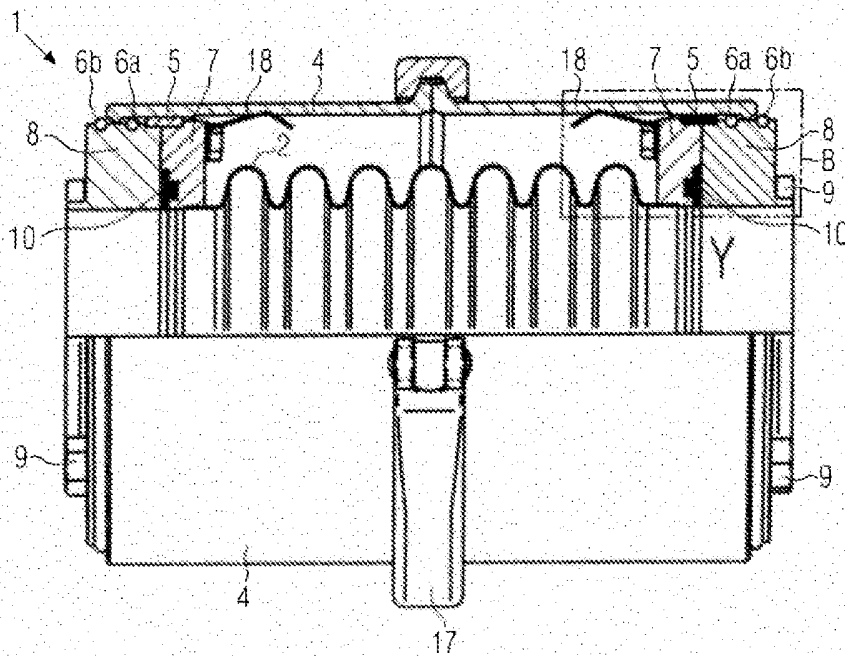

FIG. 1b

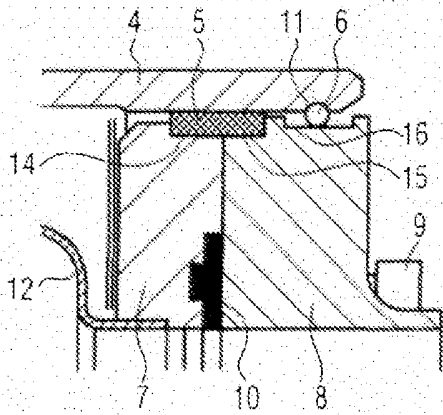

FIG. 2a

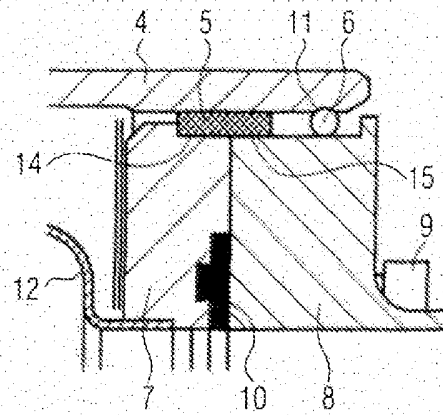

FIG. 2b

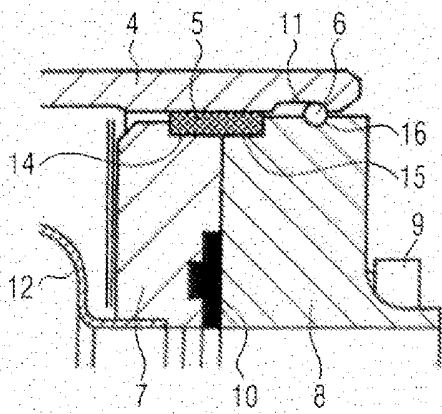

FIG. 2c

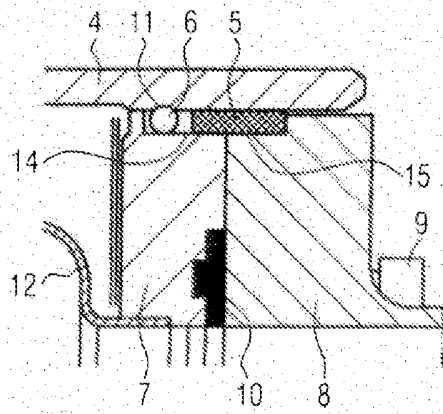

FIG. 2d

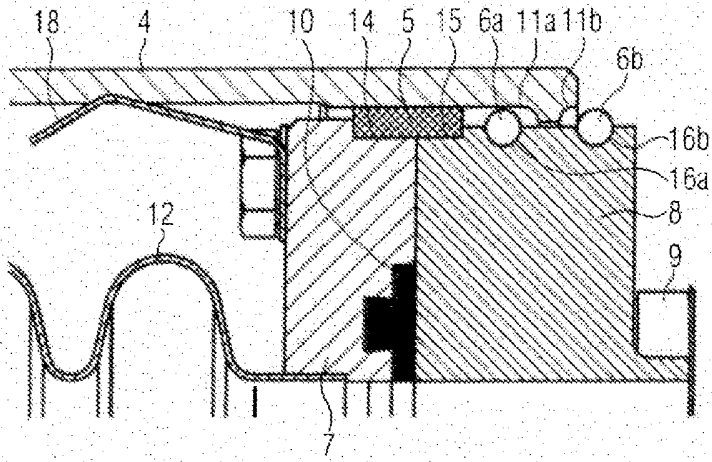

FIG. 2e

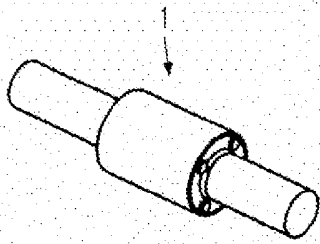

FIG. 3a

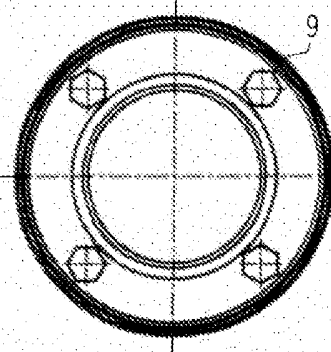

FIG. 3b

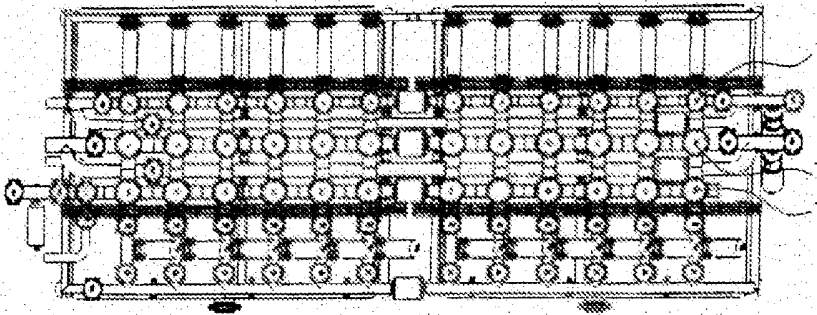

FIG. 4

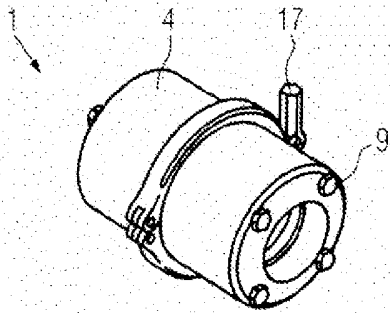

FIG. 3c

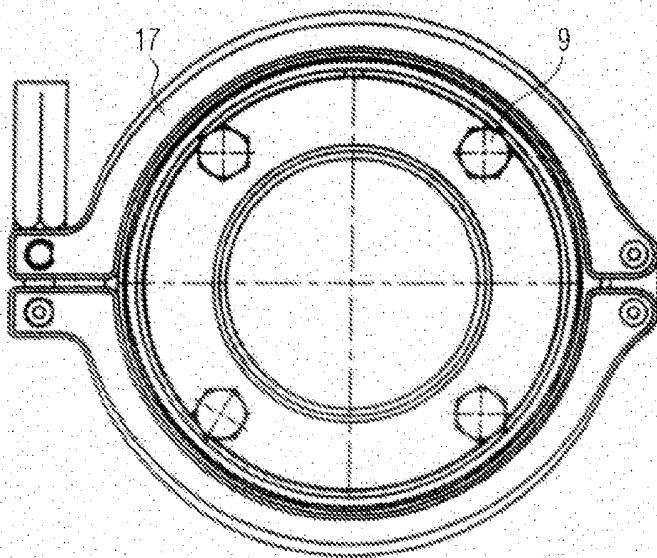

FIG. 3d