

(No Model.)

J. M. REEVES.
ROCK CHANNELING MACHINE.

No. 599,732.

Patented Mar. 1, 1898.

Fig. 1.

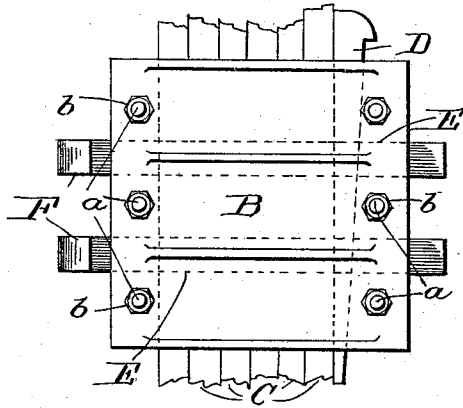

Fig. 2.

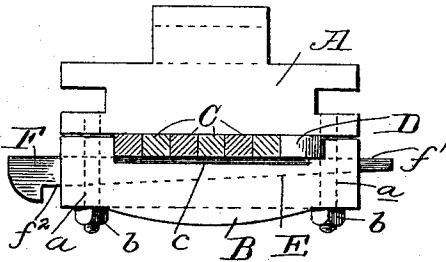

Fig. 3.

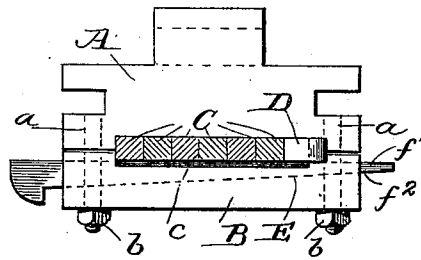
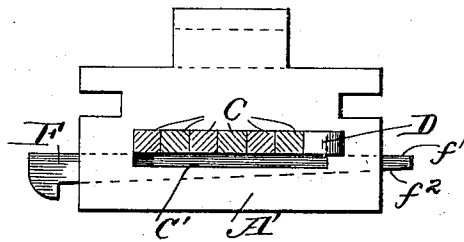

Fig. 4.



Witnesses,
Jos. H. Milans.
Chas. W. Parker

Inventor,
John Melvin Reeves
by *Joseph H. Hunter,*
Attorney

UNITED STATES PATENT OFFICE.

JOHN MCLAIN REEVES, OF BLOOMINGTON, INDIANA, ASSIGNOR OF ONE-HALF TO GEORGE D. HUNTER, OF SAME PLACE.

ROCK-CHANNELING MACHINE.

SPECIFICATION forming part of Letters Patent No. 599,732, dated March 1, 1898.

Application filed October 14, 1897. Serial No. 655,216. (No model.)

To all whom it may concern:

Be it known that I, JOHN MCLAIN REEVES, a citizen of the United States, residing at Bloomington, in the county of Monroe and State of Indiana, have invented certain new and useful Improvements in Rock-Channeling Machines, of which the following is a specification, reference being had therein to the accompanying drawings.

This invention relates to an improvement in rock-channeling machines, and particularly to the clamps employed in such machines for holding the drills or bits. Such clamps in the rock-channeling machines generally in use at the present time are constructed of two members, one secured to a reciprocating member of the machine, and the other, which constitutes what may be termed a "covering-plate," secured to the first clamp member by a plurality of bolts. The drills, of which there are usually several in number, are arranged side by side in a space formed between the clamp members, and the bolts are relied upon for forcing the cover-plate against the drills to hold the latter in place. A vertical side wedge or key is driven between one of the end drills and the clamp to bind the several drills together. In the use of such machines, after the machine has cut a channel of, say, four inches, it is necessary to stop the machine to take up what is termed "the fall"—that is, the clamps are loosened and the drills lowered a distance about equal to the depth of channel already cut. To do this properly with the above-mentioned style of clamp is an operation requiring considerable time and causing great inconvenience, inasmuch as each of the bolt-nuts and the wedges must be loosened, the drills lowered, and each of the bolt-nuts independently tightened. Besides this inconvenience and loss of time it not infrequently happens that one or more of the bolts breaks or pulls out and requires to be replaced, thus causing further trouble and delay. It is to overcome these inconveniences, prevent loss of time in use, cheapen and strengthen the clamp, and generally simplify and improve the construction of drill-clamps that my invention is designed.

With such objects in view my invention, gen-

erally speaking, consists of a clamp wherein the alined drills are bound together by a suitable means, such as a vertical wedge or key at the side of one of the end drills, and all held rigidly in place in the clamp by a wedge or key or plurality of wedges or keys placed transversely or crosswise of the drills.

In order that my invention may be properly understood, I have illustrated in the accompanying drawings a practical embodiment thereof, but wish it understood that I do not limit my invention to the particular construction therein shown.

In the said drawings, Figure 1 is an elevation of a clamp embodying my improvements, showing the drills in place. Fig. 2 is a top plan view thereof. Figs. 3 and 4 are plan views of slightly-modified forms of clamps.

Referring to the drawings, A, Figs. 1, 2, and 3, represents the fixed member of the clamp or holder, which is provided, as usual, with means for properly mounting it on the machine and maintaining it in proper position, which are common and need not be further described. To this part A are secured stud-bolts *a*, projecting outwardly from the face thereof.

B indicates the movable member or plate of the holder, provided with bolt-holes to receive the bolts *a*.

b are nuts working on the bolts *a* and adapted to force the clamp members together.

Between the adjacent faces of the clamp members a space *c* is formed for the reception of the drills C. This space may be formed, as in Fig. 2, by channeling or grooving the inner face of one plate, or, as shown in Fig. 3, the adjacent faces of each of the clamp members A and B may be provided with a shallow channel or groove, which when the members are together form a space of proper width for the drills. This much of the clamp is old and not of my invention, which, it will be readily understood, is applicable to these known forms of clamps.

D is the usual side or edge wedge or key to bind the drills together.

To apply my improvement to these clamps, I provide in the movable plate B one or more grooves or slots E, running transversely or crosswise of the drills, the bottoms of said

grooves being inclined, or, if desired, said groove may be formed in the part A, as is obvious.

F represents a wedge or key having a straight face f' and a face f^2 inclined similarly to the bottom of the groove E, said key being preferably made long enough to project out to either side of the clamp. This wedge when driven home in the slot impinges on one or more of the drills (according to conditions) and forces the latter against the holder with sufficient force to form a very efficient clamp.

In Fig. 4 I have shown instead of the members A and B a single-part holder A', provided with a hole C' sufficiently wide to permit of the passage of the drill-points, which are somewhat wider than the drill-bodies.

In using my improved clamp it is simply necessary when it is decided to "take up the fall" to strike the cross-key F with a hammer to drive it out and then strike the side key D. This will loosen up the drills, the latter dropping of their own weight the required distance. Then to again clamp the drills the cross-key F is driven reasonably firm, after which the key D is driven home. The cross-key should then be given another stroke of the hammer to drive it home, when the drills will be properly held and the machine can be started. Thus it will be seen that the drills are more firmly clamped in much less time than when nuts or bolts are employed and have to be loosened and tightened individually.

It sometimes happens that the drills after usage wear to a certain extent, and thus be-

come of different thicknesses. This, however, will not render the clamp ineffective on account of the cross-key not impinging on all of the drills, for the key D firmly binds all of the drills together, and as the cross-key F must necessarily impinge against one or more of the drills the whole row of drills is securely held.

I am aware of such a clamp as described in Patents No. 536,867 to Forsyth and No. 87,053 to Tomson and make no claim to the same.

Having thus described the invention, what I claim as new, and desire to secure by Letters Patent, is—

1. In a drill-clamp for rock-channeling machines, the combination with a holder provided with a vertical hole or slot for the drills, and a transverse groove or slot, of a vertical key D, and a transverse wedge or key in said transverse slot adapted to clamp the drills by a movement of the key transversely of the drills, substantially as described.

2. In a drill-clamp, the combination with a holder formed of two parts between which the drills are placed, and means for securing said parts together, one part being formed with a transverse groove or slot, of a vertical key D, and a wedge or key in said transverse groove or slot, and adapted to clamp the drills by a transverse movement of the key, substantially as described.

In testimony whereof I affix my signature in presence of two witnesses.

JOHN MCLAIN REEVES.

Witnesses:

THOS. A. TODD,
JNO. B. CROFTON.