

**(19) AUSTRALIAN PATENT OFFICE**

(54) Title  
Medical tissue fixation device comprising suture loops

(51)<sup>6</sup> International Patent Classification(s)  
**A61B** 17/06 (2006.01) 20060101AFI2005100  
A61B 17/06 8BMEP  
PCT/US2004/010807

(21) Application No: 2004229421 (22) Application Date: 2004 .04 .08

(87) WIPO No: W004/091412

(30) Priority Data

(31) Number	(32) Date	(33) Country
10/410,868	2003 .04 .10	US

(43) Publication Date : 2004 .10 .28

(71) Applicant(s)  
Smith & Nephew, Inc.

(72) Inventor(s)  
Hecker, Aaron, Sikora, George, Brown, Charles H. Jr.

(74) Agent/Attorney  
Davies Collison Cave, 1 Nicholson Street, Melbourne, VIC, 3000

(56) Related Art  
US 5144961  
US 5769862  
US 5643293  
US 2002/0173788

(12) INTERNATIONAL APPLICATION PUBLISHED UNDER THE PATENT COOPERATION TREATY (PCT)

(19) World Intellectual Property  
Organization  
International Bureau



(43) International Publication Date  
28 October 2004 (28.10.2004)

PCT

(10) International Publication Number  
WO 2004/091412 A1

- (51) International Patent Classification<sup>7</sup>: **A61B 17/04** Charles, H., Jr. [US/US]; 15 Cedar Street, Wellesley, MA 02181 (US).
- (21) International Application Number: PCI/US2004/010807 (74) Agent: MIRANDA, David, T.; Fish & Richardson, P.C., 225 Franklin Street, Boston, MA 02110-2804 (US).
- (22) International Filing Date: 8 April 2004 (08.04.2004)
- (25) Filing Language: English
- (26) Publication Language: English
- (30) Priority Data: 10/410,868 10 April 2003 (10.04.2003) US
- (71) Applicant (for all designated States except US): SMITH & NEPHEW, INC. [US/US]; 150 Minutemen Road, Andover, MA 01810 (US).
- (72) Inventors; and
- (75) Inventors/Applicants (for US only): SIKORA, George [US/US]; 1529 Plymouth Street, Bridgewater, MA 02324 (US). HECKER, Aaron [US/US]; 31 Mount Vernon Street, West Roxbury, MA 02132 (US). BROWN,
- (81) Designated States (unless otherwise indicated, for every kind of national protection available): AE, AG, AL, AM, AT, AU, AZ, BA, BB, BG, BR, BW, BY, BZ, CA, CH, CN, CO, CR, CU, CZ, DE, DK, DM, DZ, EC, EE, EG, ES, FI, GB, GD, GE, GH, GM, HR, HU, ID, IL, IN, IS, JP, KE, KG, KP, KR, KZ, LC, LK, LR, LS, LT, LU, LV, MA, MD, MG, MK, MN, MW, MX, MZ, NA, NI, NO, NZ, OM, PG, PH, PL, PT, RO, RU, SC, SD, SE, SG, SK, SL, SY, TJ, TM, TN, TR, TT, TZ, UA, UG, US, UZ, VC, VN, YU, ZA, ZM, ZW.
- (84) Designated States (unless otherwise indicated, for every kind of regional protection available): ARIPO (BW, GH, GM, KE, LS, MW, MZ, SD, SL, SZ, TZ, UG, ZM, ZW), Eurasian (AM, AZ, BY, KG, KZ, MD, RU, TJ, TM), European (AT, BE, BG, CH, CY, CZ, DE, DK, EE, ES, FI, FR, GB, GR, HU, IE, IT, LU, MC, NL, PL, PT, RO, SE, SI, SK,

[Continued on next page]

(54) Title: MEDICAL TISSUE FIXATION DEVICE COMPRISING SUTURE LOOPS

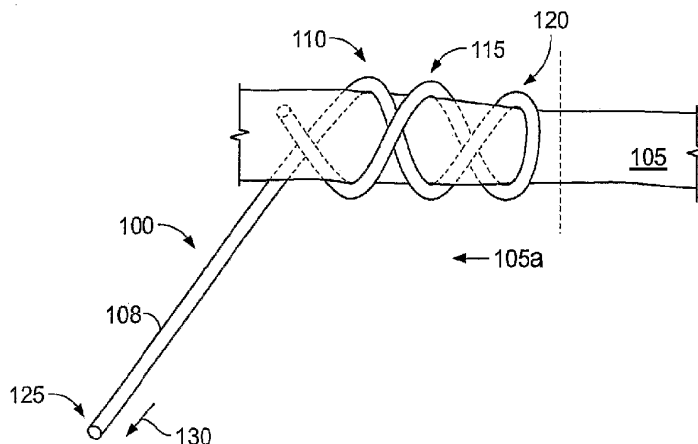

(57) Abstract: A medical device that attaches to tissue without requiring stitching includes a tissue fixation device (100) having a first sub-loop (110) and a second sub-loop (115), and an assisting member (705) disposed through the first sub-loop and through the second sub-loop. The tissue fixation device includes, for example, an adjustable, flexible member formed by inserting one end portion of the flexible member through another end portion of the flexible member, and first and second sub-loops formed by crossing a portion of the flexible member over a different portion of the flexible member.

WO 2004/091412 A1



TR), OAPI (BF, BI, CF, CG, CI, CM, GA, GN, GQ, GW, ML, MR, NE, SN, TD, TG).

**Declarations under Rule 4.17:**

- as to applicant's entitlement to apply for and be granted a patent (Rule 4.17(ii)) for the following designations AE, AG, AL, AM, AT, AU, AZ, BA, BB, BG, BR, BW, BY, BZ, CA, CH, CN, CO, CR, CU, CZ, DE, DK, DM, DZ, EC, EE, EG, ES, FI, GB, GD, GE, GH, GM, GR, HU, ID, IL, IN, IS, JP, KE, KG, KP, KR, KZ, LC, LK, LR, LS, LT, LU, LV, MA, MD, MG, MK, MN, MW, MX, MZ, NA, NI, NO, NZ, OM, PG, PH, PL, PT, RO, RU, SC, SD, SE, SG, SK, SL, SY, TJ, TM, TN, TR, TT, TZ, UA, UG, UZ, VC, VN, YU, ZA, ZM, ZW. ARIPO patent (BW, GH, GM, KE, LS, MW, MZ, SD, SL, SZ, TZ, UG, ZM, ZW), Eurasian patent (AM, AZ, BY, KG, KZ, MD, RU, TJ, TM), European patent (AT, BE, BG, CH, CY, CZ, DE, DK, EE, ES, FI, FR, GB, GR, HU, IE, IT, LU, MC, NL, PL, PT, RO, SE, SI, SK, TR), OAPI patent (BF, BI, CF, CG, CI, CM, GA, GN, GQ, GW, ML, MR, NE, SN, TD, TG)
- as to the applicant's entitlement to claim the priority of the earlier application (Rule 4.17(iii)) for the following designations AE, AG, AL, AM, AT, AU, AZ, BA, BB, BG, BR, BW,

BY, BZ, CA, CH, CN, CO, CR, CU, CZ, DE, DK, DM, DZ, EC, EE, EG, ES, FI, GB, GD, GE, GH, GM, GR, HU, ID, IL, IN, IS, JP, KE, KG, KP, KR, KZ, LC, LK, LR, LS, LT, LU, LV, MA, MD, MG, MK, MN, MW, MX, MZ, NA, NI, NO, NZ, OM, PG, PH, PL, PT, RO, RU, SC, SD, SE, SG, SK, SL, SY, TJ, TM, TN, TR, TT, TZ, UA, UG, UZ, VC, VN, YU, ZA, ZM, ZW. ARIPO patent (BW, GH, GM, KE, LS, MW, MZ, SD, SL, SZ, TZ, UG, ZM, ZW), Eurasian patent (AM, AZ, BY, KG, KZ, MD, RU, TJ, TM), European patent (AT, BE, BG, CH, CY, CZ, DE, DK, EE, ES, FI, FR, GB, GR, HU, IE, IT, LU, MC, NL, PL, PT, RO, SE, SI, SK, TR), OAPI patent (BF, BI, CF, CG, CI, CM, GA, GN, GQ, GW, ML, MR, NE, SN, TD, TG)

**Published:**

- with international search report
- before the expiration of the time limit for amending the claims and to be republished in the event of receipt of amendments

For two-letter codes and other abbreviations, refer to the "Guidance Notes on Codes and Abbreviations" appearing at the beginning of each regular issue of the PCT Gazette.

2004229421 06 May 2010

**MEDICAL TISSUE FIXATION DEVICE COMPRISING SUTURE LOOPS**

**TECHNICAL FIELD**

This invention relates to medical devices, and more particularly to a fixation device.

**BACKGROUND**

5 To perform a surgical repair, e.g., of a torn anterior cruciate ligament ("ACL"), the surgeon typically connects a length of suture to the replacement ACL soft tissue graft. The suture enables the surgeon to pull the tissue graft through holes formed in the tibia and femur for receiving the tissue graft. Typically, the surgeon attaches the suture to the ACL soft tissue graft using a whipstitch. Stitching the suture to the tissue graft using a whipstitch usually takes over  
10 two minutes per tissue graft.

**SUMMARY**

In accordance with one aspect of the present invention there is provided a medical device comprising: a first adjustable suture comprising a first sub-loop and a second sub-loop, each sub-loop configured to receive a length of tissue therethrough, the adjustable suture formed by  
15 inserting one end portion of the adjustable suture through another end portion of the adjustable suture, and the first sub-loop and the second sub-loop formed by crossing a portion of the adjustable suture over a different portion of the adjustable suture, wherein the first sub-loop and the second sub-loop are configured to fixate onto tissue; second adjustable suture comprising a first sub-loop and a second sub-loop; an assisting member disposed through the first sub-loop and  
20 through the second sub-loop of the first adjustable suture, and disposed through the first sub-loop and through the second sub-loop of the second adjustable suture.

Examples of the invention relates to a fixation device that attaches to a tissue graft without requiring stitching. One advantage is that the time it takes for the surgeon to attach the fixation device to the tissue graft is shorter than the time it takes to whipstitch a suture to the tissue graft.  
25 In one aspect, there is a medical device (e.g., tissue fixation device) that includes a member having a first sub-loop and a second sub-loop, where each sub-loop is configured to receive a length of tissue therethrough. In another aspect, there is a medical device including an adjustable loop and an assisting member. The adjustable loop includes a first sub-loop and a second sub-loop configured to receive a length of tissue therethrough. The assisting member is disposed  
30 through the first sub-loop and through the second sub-loop. In yet another aspect, there is a

2004229421 06 May 2010

medical device including an adjustable, flexible member. The adjustable, flexible member is formed by inserting one end portion of the flexible member through another end portion of the flexible member. The adjustable member is further formed into a first sub-loop and a second sub-loop. Crossing a portion of the flexible member over a different portion of the flexible member forms the first sub-loop and the second sub-loop. The first sub-loop and the second sub-loop are configured to fixate onto tissue. In another aspect, there is a medical device that includes a plurality of adjustable suture members and a cannula. In the plurality of adjustable suture members, each member includes a first sub-loop, a second sub-loop, and a third sub-loop, where each sub-loop is configured to receive a length of tissue therethrough. The cannula is disposed through the sub-loops of each of the plurality of adjustable suture members.

In other embodiments, the medical device can include one or more of the following features:

The member includes suture. The member further includes a third sub-loop configured to receive a length of tissue therethrough. The medical device includes an assisting member disposed through the first sub-loop and through the second sub-loop. The assisting member includes a medical grasping device. The assisting member comprises a cannula. The member is a first member, where the medical device also includes a second adjustable member including a first sub-loop and a second sub-loop. The assisting member is further disposed through the first sub-loop of the second adjustable tissue fixation device and through the second sub-loop of the second adjustable tissue fixation device. The member is an adjustable member formed by inserting one end portion of the adjacent member through another end portion of the adjustable member. The adjustable member is further formed into a first sub-loop and a second sub-loop. Crossing a portion of the adjustable member over a different portion of the adjustable member forms the first sub-loop and the second sub-loop. The first sub-loop and the second sub-loop are configured to fixate onto tissue. In other examples, the sub-loops are configured to fixate on ligament or tendon tissue.

In accordance with another aspect of the present invention there is provided a method for making a medical device. The method includes inserting one end portion of a flexible member through another end portion of the flexible member to form an adjustable loop. The method further includes locating a first portion of the adjustable loop over a second portion of the adjustable loop to form a first sub-loop and a second sub-loop, where the sub-loops configured to receive a length of tissue.

2004229421 05 Oct 2010

In one example, the method also includes locating a first portion of the second sub-loop over a second portion of the second sub-loop to form a third sub-loop. In another example, the flexible member comprises suture. In another example, the method also includes locating further comprises rotating a portion of the adjustable loop approximately 180 degrees of rotation. In another example, the method also includes sliding the first portion of the adjustable loop over the second portion of the adjustable loop to form a first sub-loop and a second sub-loop.

In yet another example, the method also includes locating a first portion of an assisting member within the first sub-loop and a second portion of the assisting member within the second sub-loop. In one example, the assisting member includes a medical grasping device. In another example, the assisting member comprises a cannula. In another example, the flexible member is a first flexible member. In this example, the method also includes inserting one end portion of a second flexible member through another end portion of the second flexible member to form a second adjustable loop, locating a first portion of the second adjustable loop over a second portion of the second adjustable loop to form a first sub-loop and a second sub-loop and locating a third portion of the assisting member within the first sub-loop of the second flexible member and a fourth portion of the assisting member within the second sub-loop of the second flexible member.

In accordance with another aspect of the present invention there is provided a method for attaching a fixation device to tissue. The method includes moving a first sub-loop and a second sub-loop of the fixation device over a portion of the tissue and pulling an end portion of the fixation device to reduce the size of the sub-loops to fixate the fixation device to the portion of the tissue. In one example, the method also includes moving a third sub-loop over the portion of tissue. In another example, the method also includes grasping tissue with an assisting member located within the first and second sub-loops. In another example, the method also includes sliding the first sub-loop and the second sub-loop off of the assisting member. In another example, the fixation device comprises suture. In another example, the tissue comprises ligament or tendon graft.

#### DESCRIPTION OF DRAWINGS

The invention is described, by way of non-limiting example only, with reference to the accompanying drawings, in which:

FIG. 1 is a side view of a fixation device connected to tissue.

FIG. 2 is a side view of an adjustable loop.

FIG. 3 is a perspective view of the adjustable loop.

5 FIG. 4 is a side view of two sub-loops formed from the adjustable loop.

FIG. 5 is a side view of three sub-loops formed from the adjustable loop to produce the fixation device.

FIG. 6 is a side view of an alternative embodiment of three sub-loops formed from the adjustable loop of FIG. 2 to produce the fixation device.

10 FIG. 7A is a side view of the fixation device over a cannula.

FIG. 7B is a side view of a plurality of fixation devices over a cannula.

FIG. 8 is a side view of the fixation device over a cannula being used with a medical grasping device.

FIG. 9 is a side view of the fixation device over a medical grasping device.

15 **DETAILED DESCRIPTION**

Referring to FIG. 1, a fixation device 100 includes a length of flexible material, e.g., a suture 108 formed into a first sub-loop 110, a second sub-loop 115, and a third sub-loop 120. As described in more detail below, sub-loops 110, 115, and 120 are formed and wrapped around tissue 105 such that when a surgeon pulls an end 125 of suture 108 in a direction indicated by  
20 arrow 130, sub-loops 110, 115, and 120 constrict around and thus fixate on a portion 105a of tissue 105. This allows the surgeon to pull tissue 105 by pulling end 125 of fixation device 100 and provides a limitless gripping force in that as the tension applied to 125 increases, the constriction of the loops around tissue 105 increases. In other words, the harder the surgeon pulls, the tighter sub-loops 110, 115, and 120 constrict around portion 105a of tissue 105. Tissue

105 includes, for example, a replacement ligament or tendon. Suture 108 includes, for example, medical grade suture suitable for use in a surgical procedure.

Referring to FIGS. 2 and 3, fixation device 100 is constructed by initially forming suture 108 into an adjustable loop 205. Adjustable loop 205 is formed by passing end 125 of suture 108 through an opposite end 210 of suture 108. For example, suture end 125 is pushed through end 210 such that portions 108a and 108b of suture end 210 define a hole 305. Alternatively, hole 305 is preformed in suture end 210 and suture end 125 is passed through the hole. As constructed, suture 108 easily slides through hole 305 to increase or decrease the size of adjustable loop 205. This mechanism also allows the surgeon to increase and decrease the size of any sub-loops formed from adjustable loop 205 when the surgeon pulls on end 125.

Referring to FIG. 4, rotating adjustable loop 205 one-half turn, approximately 180 degrees, around an axis 400 generates sub-loops 110 and 115. As illustrated, the rotation is in a direction indicated by arrow 405. This rotation causes a first portion 410 of adjustable loop 205 to cross and overlap a second portion 415 of adjustable loop 205. The overlapping portions 410 and 415 define part of the boundaries of sub-loops 110 and 115. Axis 400 also represents how tissue 105 (FIG. 1) passes through sub-loops 110 and 115. As illustrated, tissue 105 goes into the center of second sub-loop 115, under (with respect to the illustrated viewing angle) overlapping portions 410 and 415, and out of the center of the first sub-loop 110.

Referring to FIG. 5, rotating sub-loop 115 another one-half turn, approximately 180 degrees, around axis 400 generates the third sub-loop 120. This rotation causes a third portion 510 of adjustable loop 205 to cross and overlap a fourth portion 515 of adjustable loop 205. The overlapping portions 510 and 515 define part of the boundaries of sub-loops 115 and 120. Axis 400 also represents how tissue 105 (FIG. 1) passes through sub-loops 110, 115 and 120. As illustrated, tissue 105 goes into the center of third sub-loop 120 and over (with respect to the illustrated viewing angle) overlapping portions 510 and 515. Tissue 105 also goes into the center of second sub-loop 115, under (with respect to the illustrated viewing angle) overlapping portions 410 and 415, and out of the center of the first sub-loop 110. This process can be repeated multiple times to generate multiple sub-loops from adjustable loop 205. An advantage

to having three sub-loops over two sub-loops, as depicted in FIG. 4, is that additional loops provide greater tissue to suture purchase, along with greater capacity for load distribution.

Rotating adjustable loop 205, or a portion thereof, is one way to generate sub-loops 110, 115, and 120. There are, however, other processes to generate sub-loops 110, 115, and 120. FIG. 6 illustrates one of those alternative processes to generate sub-loops 110, 115, and 120. As illustrated in FIG. 6, starting with the adjustable loop 205 of FIG. 2, one side of adjustable loop 205 is moved in the direction of arrow 605 while an opposite side of adjustable loop 205 is moved in the direction of arrow 610. The moving sides eventually overlap at portions 410, 415, 510, and 515, generating sub-loops 110, 115, and 120. In this process, unlike the rotation process illustrated in FIG. 5, fourth portion 515 of adjustable loop 205 crosses and overlaps third portion 510 of adjustable loop 205 (with respect to the illustrated viewing angle).

Referring to FIG. 7A, to aid in positioning sub-loops 110, 115, and 120 around tissue 105, a device, e.g., 705 is placed through sub-loops 110, 115, and 120 along axis 400. Referring to FIG. 7B, cannula 705 can include a plurality of fixation devices 100 and 100'. In another example (not shown), cannula 705 includes four fixation devices 100.

Referring to FIG. 8, to transfer fixation device 100 from cannula 705 onto tissue 105, a surgeon uses a grasping device 805, inserted through cannula 705, to grasp tissue 105. With tissue 105 located at an end 810 of cannula 705, the surgeon manually slides sub-loops 110, 115, and 120 in a direction indicated by arrow 815. Sub-loops 110, 115, and 120 slide off of cannula 705 and onto tissue 105. As illustrated, fixation device 100 slides off of cannula 705, onto grasping device 805 and then onto tissue 105.

In an alternative example, the surgeon can locate end 810 of cannula 705 directly over tissue 105 so that when fixation device 100 slides off of cannula 705, it falls directly onto tissue 105. In yet another alternative example, with a plurality of fixation devices 100 located on cannula 705, after attaching a first fixation device to tissue 105, the surgeon grasps another piece of tissue and slides second fixation device onto the other piece of tissue without the need to reload a fixation device between attachments.

2004229421 06 May 2010

Throughout this specification and the claims which follow, unless the context requires otherwise, the word "comprise", and variations such as "comprises" and "comprising", will be understood to imply the inclusion of a stated integer or step or group of integers or steps but not the exclusion of any other integer or step or group of integers or steps.

- 5 The reference in this specification to any prior publication (or information derived from it), or to any matter which is known, is not, and should not be taken as an acknowledgment or admission or any form of suggestion that that prior publication (or information derived from it) or known matter forms part of the common general knowledge in the field of endeavour to which this specification relates.

2004229421 06 May 2010

THE CLAIMS DEFINING THE INVENTION ARE AS FOLLOWS:

1. A medical device comprising:  
a first adjustable suture comprising a first sub-loop and a second sub-loop, each sub-  
5 loop configured to receive a length of tissue therethrough, the adjustable suture formed by  
inserting one end portion of the adjustable suture through another end portion of the  
adjustable suture, and the first sub-loop and the second sub-loop formed by crossing a portion  
of the adjustable suture over a different portion of the adjustable suture, wherein the first sub-  
loop and the second sub-loop are configured to fixate onto tissue;  
10 second adjustable suture comprising a first sub-loop and a second sub-loop;  
an assisting member disposed through the first sub-loop and through the second sub-  
loop of the first adjustable suture, and disposed through the first sub-loop and through the  
second sub-loop of the second adjustable suture.
- 15 2. The medical device of claim 1 wherein the member further comprises a third sub-loop  
configured to receive a length of tissue therethrough.
3. The medical device of claims 1 or 2 wherein the assisting member comprises a  
medical grasping device.
- 20 4. The medical device of any one of claims 1 to 3 wherein the assisting member  
comprises a cannula.
5. The medical device of any one of claims 1 to 4 wherein the sub-loops are configured  
25 to fixate on ligament or tendon tissue.
6. A method for making a medical device comprising:  
inserting one end portion of a flexible member through another end portion of the  
flexible member to form an adjustable loop; and  
30 locating a first portion of the adjustable loop over a second portion of the adjustable  
loop to form a first sub-loop and a second sub-loop, the sub-loops configured to receive a  
length of tissue.

2004229421 05 Oct 2010

7. The method of claim 6 further comprising:  
locating a first portion of the second sub-loop over a second portion of the second sub-loop to form a third sub-loop.
- 5 8. The method of claim 6 or 7 wherein the flexible member comprises suture.
9. The method of any of claims 6 to 8 wherein locating further comprises rotating a portion of the adjustable loop approximately 180 degrees of rotation.
- 10 10. The method of any of claims 6 to 9 wherein locating further comprises sliding the first portion of the adjustable loop over the second portion of the adjustable loop to form a first sub-loop and a second sub-loop.
11. The method of any one of claims 6 to 10 further comprising locating a first portion of  
15 an assisting member within the first sub-loop and a second portion of the assisting member within the second sub-loop.
12. The method of claim 11 wherein the assisting member comprises a medical grasping device.
- 20 13. The method of claim 11 or 12 wherein the assisting member comprises a cannula.
14. The method of any of claims 11 to 13 wherein the flexible member is a first flexible member, the method further comprising:  
25 inserting one end portion of a second flexible member through another end portion of the second flexible member to form a second adjustable loop;  
locating a first portion of the second adjustable loop over a second portion of the second adjustable loop to form a first sub-loop and a second sub-loop; and  
locating a third portion of the assisting member within the first sub-loop of the second  
30 flexible member and a fourth portion of the assisting member within the second sub-loop of the second flexible member.

2004229421 05 Oct 2010

15. A medical device substantially as hereinbefore described with reference to the drawings and/or Examples.
16. A method for making a medical device substantially as hereinbefore described with  
5 reference to the drawings and/or Examples.
17. A method for attaching a fixation device to a tissue substantially as hereinbefore described with reference to the drawings and/or Examples.

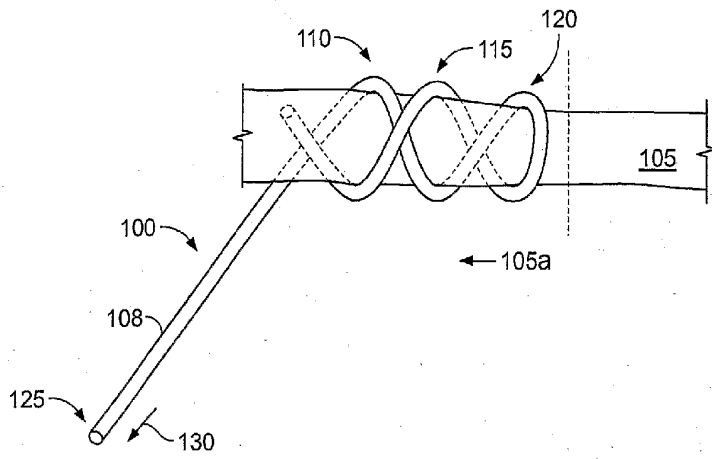

FIG. 1

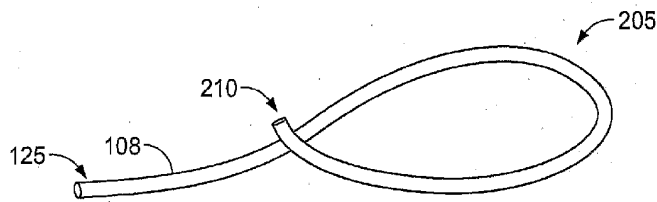

FIG. 2

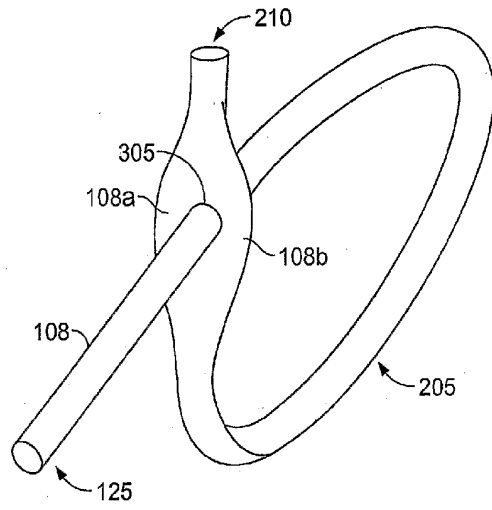

FIG. 3

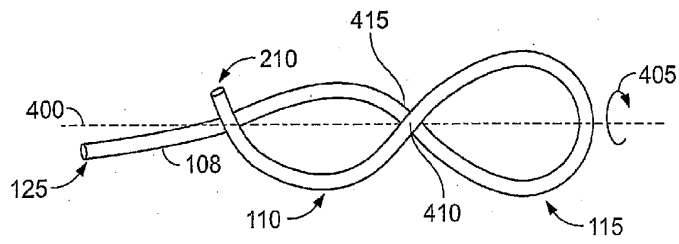

FIG. 4

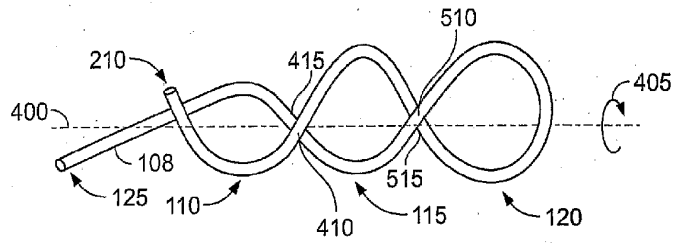

FIG. 5

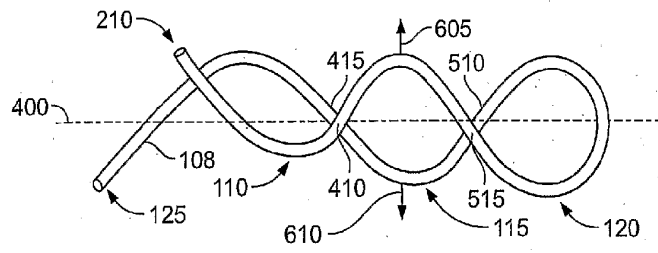

FIG. 6

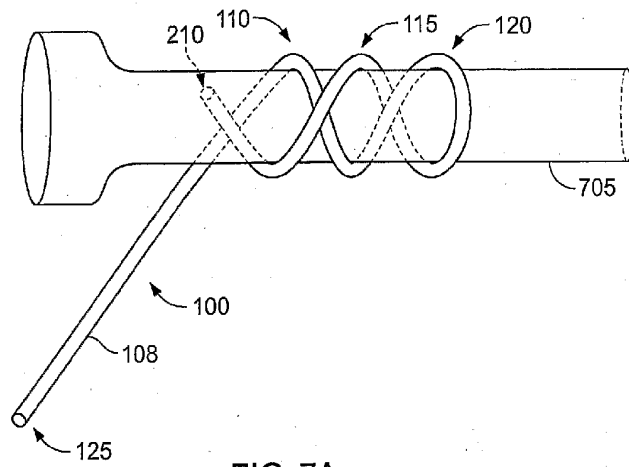

FIG. 7A

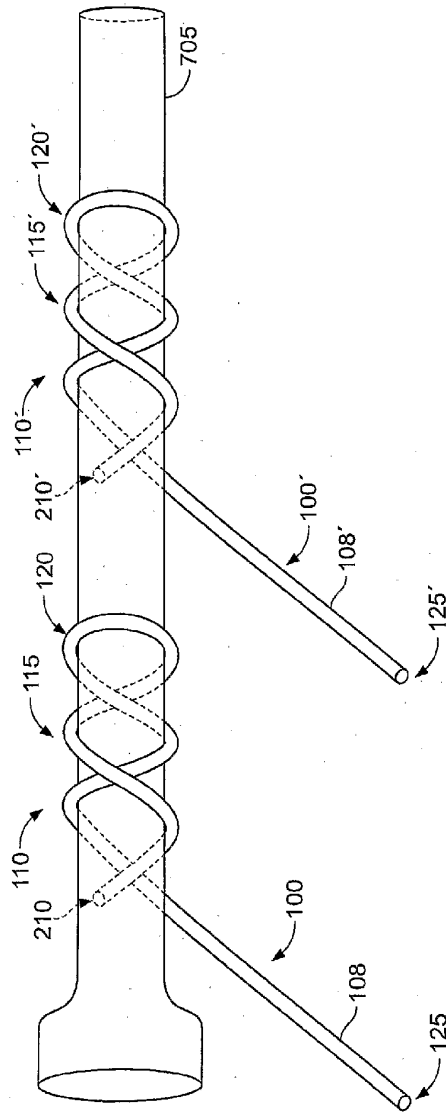

FIG. 7B

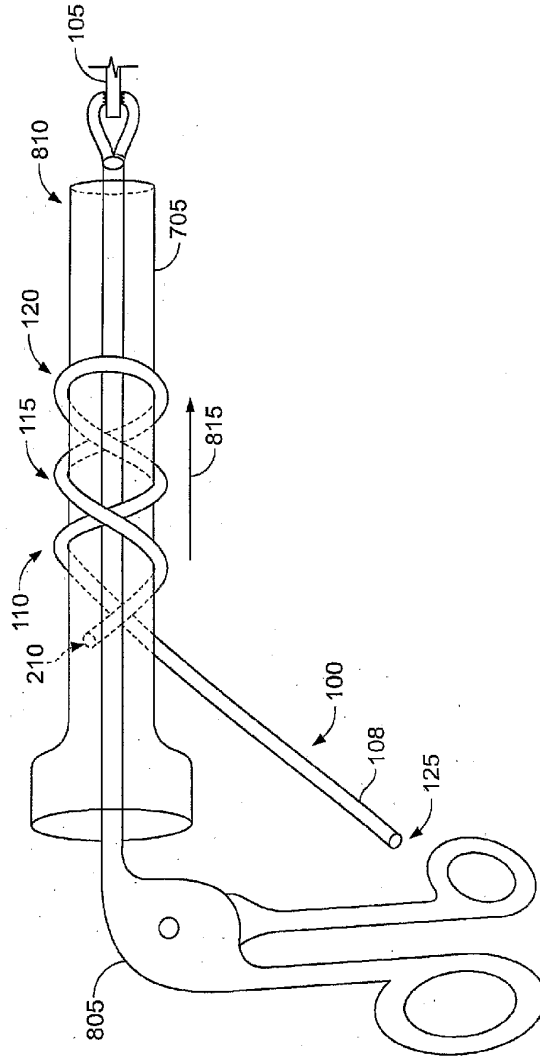

FIG. 8

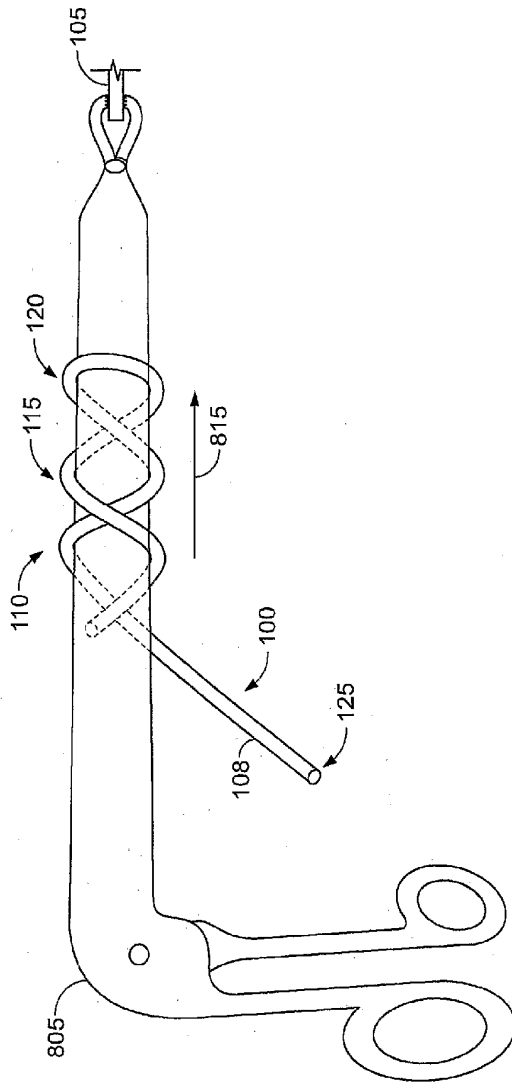

FIG. 9