



INTERNATIONAL APPLICATION PUBLISHED UNDER THE PATENT COOPERATION TREATY (PCT)

<p>(51) International Patent Classification ⁶ : D21F 1/32</p>	<p>A1</p>	<p>(11) International Publication Number: WO 96/23101 (43) International Publication Date: 1 August 1996 (01.08.96)</p>
<p>(21) International Application Number: PCT/FI96/00044 (22) International Filing Date: 22 January 1996 (22.01.96) (30) Priority Data: 950281 23 January 1995 (23.01.95) FI (71) Applicant (for all designated States except US): EV GROUP OY [FI/FI]; Kirkkokatu 8 A, FIN-48100 Kotka (FI). (72) Inventors; and (75) Inventors/Applicants (for US only): KOSKINEN, Pekka [FI/FI]; Metsäkulmankatu 40, FIN-48910 Kotka (FI). HAVERINEN, Timo [FI/FI]; Maskulantie 1 C 16, FIN-21250 Masku (FI). (74) Agent: OY HEINÄNEN AB; Annankatu 31-33 C, FIN-00100 Helsinki (FI).</p>		<p>(81) Designated States: AL, AM, AT, AU, AZ, BB, BG, BR, BY, CA, CH, CN, CZ, DE, DK, EE, ES, FI, GB, GE, HU, IS, JP, KE, KG, KP, KR, KZ, LK, LR, LS, LT, LU, LV, MD, MG, MK, MN, MW, MX, NO, NZ, PL, PT, RO, RU, SD, SE, SG, SI, SK, TJ, TM, TR, TT, UA, UG, US, UZ, VN, ARIPO patent (KE, LS, MW, SD, SZ, UG), Eurasian patent (AZ, BY, KG, KZ, RU, TJ, TM), European patent (AT, BE, CH, DE, DK, ES, FR, GB, GR, IE, IT, LU, MC, NL, PT, SE), OAPI patent (BF, BJ, CF, CG, CI, CM, GA, GN, ML, MR, NE, SN, TD, TG).</p> <p>Published With international search report.</p>

(54) Title: METHOD OF APPARATUS FOR CLEANING OF FABRICS, PARTICULARLY FABRICS OF A PAPER MACHINE

(57) Abstract

Method of cleaning a fabric, particularly a paper machine fabric. The fabric (1) is led at least through one roll or cylinder (2) and the cleaning liquid is introduced into a gap (3) (closing nip) defined by the fabric (1) and the roll or the cylinder (2), into which gap the fabric (1) is coming.

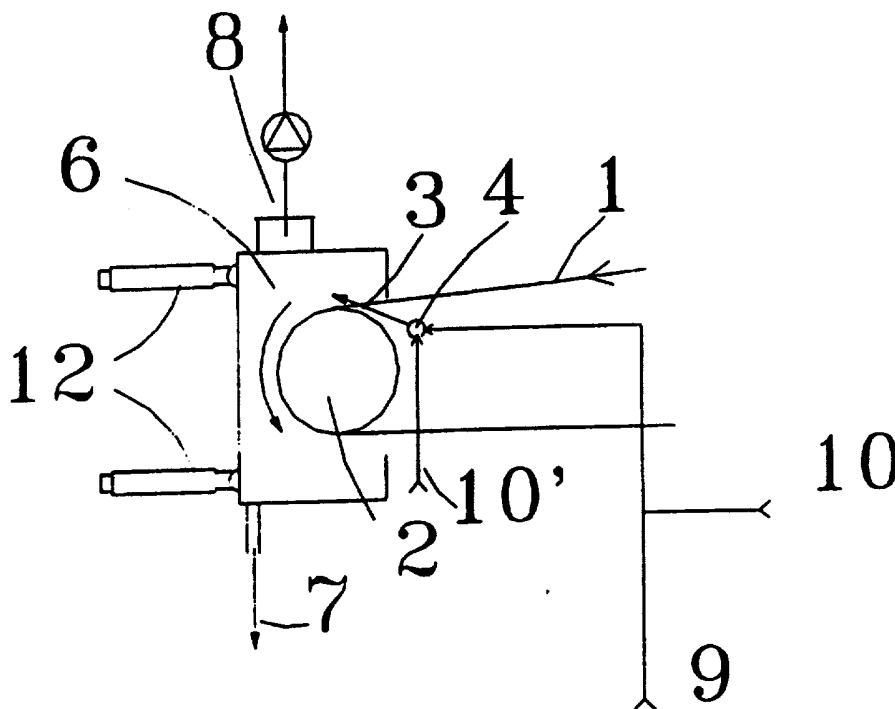

FOR THE PURPOSES OF INFORMATION ONLY

Codes used to identify States party to the PCT on the front pages of pamphlets publishing international applications under the PCT.

AM	Armenia	GB	United Kingdom	MW	Malawi
AT	Austria	GE	Georgia	MX	Mexico
AU	Australia	GN	Guinea	NE	Niger
BB	Barbados	GR	Greece	NL	Netherlands
BE	Belgium	HU	Hungary	NO	Norway
BF	Burkina Faso	IE	Ireland	NZ	New Zealand
BG	Bulgaria	IT	Italy	PL	Poland
BJ	Benin	JP	Japan	PT	Portugal
BR	Brazil	KE	Kenya	RO	Romania
BY	Belarus	KG	Kyrgystan	RU	Russian Federation
CA	Canada	KP	Democratic People's Republic of Korea	SD	Sudan
CF	Central African Republic	KR	Republic of Korea	SE	Sweden
CG	Congo	KZ	Kazakhstan	SG	Singapore
CH	Switzerland	LI	Liechtenstein	SI	Slovenia
CI	Côte d'Ivoire	LK	Sri Lanka	SK	Slovakia
CM	Cameroon	LR	Liberia	SN	Senegal
CN	China	LT	Lithuania	SZ	Swaziland
CS	Czechoslovakia	LU	Luxembourg	TD	Chad
CZ	Czech Republic	LV	Latvia	TG	Togo
DE	Germany	MC	Monaco	TJ	Tajikistan
DK	Denmark	MD	Republic of Moldova	TT	Trinidad and Tobago
EE	Estonia	MG	Madagascar	UA	Ukraine
ES	Spain	ML	Mali	UG	Uganda
FI	Finland	MN	Mongolia	US	United States of America
FR	France	MR	Mauritania	UZ	Uzbekistan
GA	Gabon			VN	Viet Nam

**METHOD OF APPARATUS FOR CLEANING OF FABRICS, PARTICULARLY
FABRICS OF A PAPER MACHINE**

The present invention is directed to a method of
5 cleaning fabrics, particularly a paper machine fabrics.

The present invention is also directed to an apparatus
for cleaning fabrics, particularly a paper machine
fabrics.

10

Fouling of the fabrics has been experienced to be a
problem in present fast running paper machines and
particularly in such a machines which use fillers and/or
recycled fibres. In addition, or alternatively to that,
15 particularly the fast decreasing of permeability of the
first drying fabrics or wires after the machine has been
started is becoming more and more common, particularly in
machines where so called suction rolls and web
stabilizers are used for supporting the web in contact
20 with the drying fabric. In such a case also dust and/or
other particles in surrounding air and/or in the web is
sucked through the fabric. Dust or other particles
decrease rapidly the permeability of the fabric and thus
eg. reduce the effect of the web stabilizing equipment,
25 which may result in a need of decreasing the speed of the
machine.

In presently used cleaning methods the cleaning of
fabrics is typically accomplished by blowing pressurized
30 air or cleaning liquid through the fabric with special
nozzles, which are moved across the running direction of
the fabric. In such a case, even if there were several
nozzles adjacent to each other, a considerably long
period of time is required for good cleaning result in
35 order to have the whole fabric treated.

It is an intention of the present invention to provide a
totally new method of cleaning of fabric, with which
method shortcomings of prior art are minimized.

- 2 -

It is also an intention of the present invention to provide a totally new apparatus for cleaning of fabric, with which method shortcomings of prior art are avoided.

5

Mainly it is characteristic to the present invention what is stated in the appending claims.

The solution according to the present invention has several considerable advantages compared to prior art systems. The method according to the present invention is very quick. The whole fabric may be cleaned over its whole area even during a short break. For example, when a machine speed being 1300 m/min and the fabric having a
10
15
20
length of 45 m, the cleaning of the fabric takes place about 29 times during a one minute cleaning period. Thus the method of the present invention does not require long shut-down periods of the paper machine. Also, the cleaning is accomplished during normal running conditions, that is running normal operation speed.

The invention will be explained in following by means of preferred examples referring to the following figures, in which

25

Figure 1 depicts an exemplary embodiment according to the present invention,

Figure 2 depicts another exemplary embodiment according to the present invention,

30

Figure 3 depicts still another exemplary embodiment according to the present invention,

Figure 4 depicts still another embodiment according to the present invention, and

35

Figure 5 depicts still another embodiment according to the present invention.

In the case of Figure 1 the fabric (1), such as a wire or felt of a paper machine has been arranged to run along the roll or cylinder (2). The gap (3) defined by the fabric (1) and the cylindric surface (of a cylinder of a roll) is called a nip. The nip is called as closing nip, if the fabric (1) is coming into the gap, and respectively as opening nip if the fabric (1) in leaving the gap. According to the invention liquid for cleaning the fabric is introduced into the closing nip (3), between the fabric (1) and roll (2). Thus the liquid is pressed between the roll (2) and the fabric (1) and further into the fabric (1) disengaging therefrom by an effect of eg. centrifucal force caused by the rotation of the roll (2). The liquid is thus carried along through the fabric. The fabric is cleaned of its whole width several times even during a period of one minute. In case the paper machine speed is 1300 m/min and the fabric having a lenght of 45 m, the cleaning of the fabric takes place about 29 times during a one minute cleaning action. Thus the cleaning of the fabric (1) according to the method of the present invention does not require long shut-down periods of the paper machine. The cleaning is preferably performed while the machine is running its normal operation speed.

The device (4) for introducing and spreading the cleanig liquid is preferably arranged into the drying section of the paper machine, for example in connection with a web stabilizers (5) nearest to the press section, preferably into a closing nip of a leading roll at press section side of the stabilizer (5). The device for introducing (4) and spreading the cleaning liquid comprises for example a duct means across the running direction of the fabric, to wall of which openings or nozzles are arranged for introducing cleaning liquid between the fabric and the roll. In the Figures a presently preferred direction of sprayed cleaning liquid is illustrated by an arrow. Openings or nozzles are arranged into the duct means

- 4 -

preferably equally spaced to provide substantially even introduction of the liquid over the whole width of the fabric.

- 5 The device for introducing and spreading the cleaning liquid (4) may be rigidly attached to a paper web stabilizers used at least in a part of the drying section of a paper machine as shown in Figures 1 and 2.
- 10 Means for collecting (6) the the cleaning liquid may be arranged in connection with a roll or a cylinder, preferably to opposite side of the fabric than the device (4) for introducing and spreading the cleaning liquid. Preferably the means for collecting (6) the the cleaning
- 15 liquid comprise a hood (6) provided with liquid (7) and gas (8) exhaust outlets. The hood (6) may be designed suitably for each individual application. It may be slightly different eg. in case the fabric is moving opposite direction of that shown in Figure 3.
- 20 Presently it is considered advantageous to use hot water having temperature between 40 - 100°C as the cleaning liquid. It is also possible to use some suitable detergent or solvent in connection with or in addition to
- 25 using hot water. The detergent or solvent may be introduced by the device for introducing and spreading the cleaning liquid provided with a detergent or solvent introduction inlet (10, 10') arranged for example directly to device (4) or to ductwork delivering the
- 30 cleaning liquid (9).

The hood (6) is movable/rotateably installed, and preferably provided with means for moving (12) and/or rotating the hood (12') in order to facilitate the

35 changing of fabric. The hood may also comprise means for introducing cleaning agent (13) inside the hood, which cleaning agent may be for example hot water or some detergent or solvent.

- 5 -

In Figure 4 there is shown an embodiment where an air blowing box (11a) is provided adjacent to opening nip of the roll or cylinder (2). There is also an air blowing box (11b) provided adjacent to the fabric on opposite side to the upper blowing box (11a). The air blowing box (11a, 11b) is provided in operational connection with the fabric (1) leaving the opening nip of the roll or cylinder (2). The air blowing box forms over pressure between the fabric and the box surface which causes an air flow through the fabric expelling possible remaining cleaning liquid from the fabric. The blowing box preferably comprises so called over pressure foil nozzles. Blowing box (11a, 11b) is advantageous for example for the following reasons. It forms a considerably large over pressure area even through requiring only minimized amount of air due to its two narrow nozzles on both sides of the box. The embodiment of Figure 4 is only exemplary and it is presently believed that it is an advantageous embodiment of the invention. However, it may be also possible to use only one of either the upper (11a) or lower (11b) blowing box if some specific situation so calls for.

In Figure 5 there is shown another embodiment almost similar to that of Figure 4 but having the air blowing boxes (11a, 11b) provided in a distance from the roll or cylinder (2), also the direction of movement of the fabric is opposite to that of Figure 4. The dashed line between the roll or cylinder (2) and the air blowing boxes (11a, 11b) illustrates that there may even be some means, such as rolls or cylinders, for changing the moving direction of the fabric (1) between the roll or cylinder (2) and the air blowing boxes (11a, 11b). This embodiment may come in question for example if the space is for some reason limited for construction shown in Figure 4. However, it may be also possible to use only one of either the upper (11a) or lower (11b) blowing box if some specific situation so calls for.

- 6 -

The air blowing box (11a, 11b) is provided with nozzle arrangement including a nozzle or nozzles selected from a group of at least so called over pressure foil nozzle and a slot nozzle. Thus the blowing box may comprise so
5 called over pressure foil nozzles or a slot nozzle adjacent the roll or fabric surface blowing air against the direction of the movement of the roll or fabric surface. The air flow may also be directed perpedicularly to the fabric.

10

The blowing box (11a, 11b) is advantageous for example for the following reasons. It forms a considerably large over pressure area even through it requires only minimized amount of air due to its considerably narrow
15 nozzles.

The air used in the air blowing box may be hot and considerably dry air, thus providing also evaporation of the water in the fabric. The air may for example from an
20 air source providing air for web stabilizers or web turning air device(s).

It is clear to a man skilled in the art that the invention is not limited to the described embodiments.
25 The features described above may be for example combined differently according to requirement of each application. Thus it is clear that the scope of the present invention may vary within the accompanied patent claims.

CLAIMS:

1. Method of cleaning a drying fabric of a paper machine, wherein the fabric (1) is led at least through one roll or cylinder (2) characterized in that
- 5
- the cleaning liquid is introduced into a gap (3) (closing nip) defined by the fabric (1) and the roll or the cylinder (2), into which gap the fabric (1) is coming,
- 10
- the cleaning liquid is pressed between the roll or cylinder (2) and the fabric (1) and is caused to be carried along through the fabric, and
 - the cleaning liquid is spread along the whole width of the fabric.
- 15
2. A method according to claim 1 characterized in that
- the cleaning liquid is spread substantially evenly over the whole width of the fabric (1) and disengaged from the fabric (1) by an effect of eg. centrifugal force caused
- 20
- by the rotation of the roll (2).
3. A method according to claims 1 or 2 characterized in that the cleaning liquid is spread with device (4), which is arranged in connection with web stabilizer equipment
- 25
- known as such.
4. A method according to some of claims 1-3 characterized in that the device (4) for introducing and spreading cleaning liquid is arranged into the drying section of
- 30
- the paper machine, in connection with a web stabilizers (5) nearest to the press section, preferably into front side of an closing nip of a leading roll at press section side of the stabilizer (5).
- 35
5. A method according to any of claims 1-4 characterized in that the cleaning liquid is collected with means for collecting (6) the the cleaning liquid, such as a hood, arranged in connection with a roll of a cylinder.

- 8 -

6. A method according to any of claims 1-4 characterized in that hot water having temperature substantially between 40 - 100°C is used as the cleaning liquid.

5 7. A method according to claim 6 characterized in that some suitable detergent or solvent is used in connection with or in addition to using hot water.

8. A method according to claim 7 characterized in that
10 the detergent or solvent is introduced by the device (4) for introducing and spreading the cleaning liquid provided with a detergent or solvent introduction inlet (10, 10') arranged directly to the device (4) or to ductwork delivering the cleaning liquid (9).

15

9. A method according to claim 1 characterized in that at least one air blowing box (11a, 11b) is provided adjacent to the fabric leaving the roll or cylinder 2, the method comprising the steps of

20 - forming over pressure between the fabric and the box surface by said air blowing box (11a, 11b),
- causing an air flow through the fabric, and
- expelling possible remaining cleaning liquid from the fabric along the air flow through the fabric.

25

10. A method according to claim 1 characterized in that the air blowing box (11a, 11b) form the over pressure by means of so called over pressure foil nozzles or a slot nozzle or a combination thereof, providing an air flow
30 against the direction of the movement of the roll or fabric surface, or perpendicularly to the fabric.

11. An apparatus for cleaning a fabric of a papermachine, including at least one roll or a cylinder (2) and a
35 fabric (1), and wherein the fabric is led at least along said roll or cylinder characterized by

- device for introducing and spreading cleaning liquid into a gap (3) (closing nip), over the whole width of the fabric, the gap (3) being defined by the fabric (1) and

the roll or cylinder (2), into which gap the fabric (1) is coming.

12. An apparatus according to claim 11 characterized in that the device (4) for introducing and spreading cleaning liquid into a gap (3) is arranged in connection with a web stabilizer equipment.

13. An apparatus according to claim 11 characterized in that the apparatus further comprises means for collecting (6) the cleaning liquid, such as a hood, arranged in connection with the roll or cylinder (2).

14. An apparatus according to claim 11 characterized in that the apparatus further comprises a detergent or solvent introduction inlet (10, 10') arranged directly to the device (4) or to ductwork delivering the cleaning liquid(9).

15. An apparatus according to claim 11 characterized in that at least one air blowing box (11a, 11b) is provided in operational connection with the fabric (1) leaving the opening nip of the roll or cylinder (2).

16. An apparatus according to claim 15 characterized in that the air blowing box (11a, 11b) is provided adjacent to the the roll or cylinder (2).

17. An apparatus according to claim 15 characterized in that the air blowing box (11a, 11b) is provided with nozzle arrangement including a nozzle or nozzles selected from a group of so called over pressure foil nozzle and a slot nozzle.

18. An apparatus according to claim 15 characterized in that the air blowing box (11a, 11b) is provided with nozzle arrangement including a nozzle or nozzles being directed to blow air against the direction of movement of

- 10 -

the roll or fabric surface, or perpendicularly against the fabric.

19. An apparatus according to claim 13 characterized in
5 that the means for collecting (6) the cleaning liquid (the hood), is movably/rotateably installed and preferably provided with means for moving (12) and/or rotating (12') the hood in order to facilitate changing of fabric.

10

20. An apparatus according to claim 13 characterized in
that the means for collecting (6) the cleaning liquid (the hood), is preferably provided with means for introducing cleaning agent (13) inside the hood (6).

15

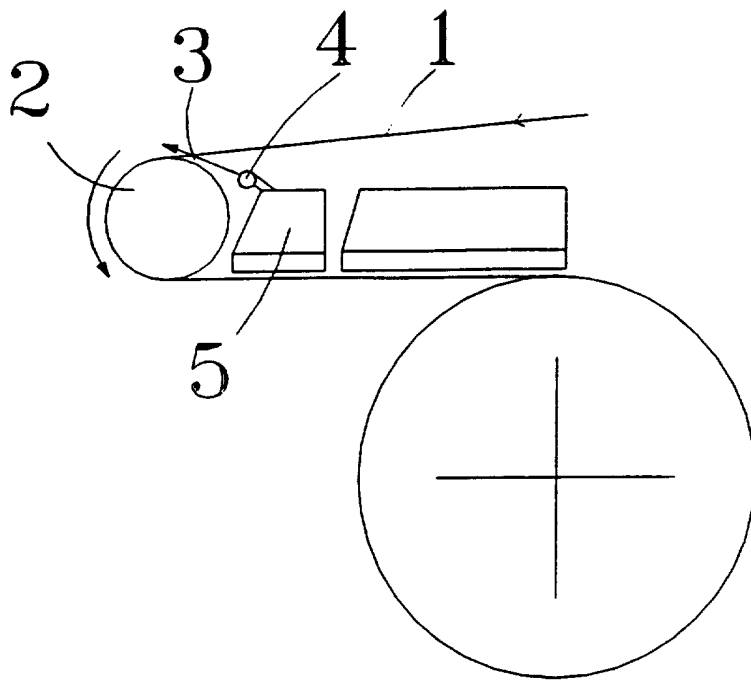

Fig. 1

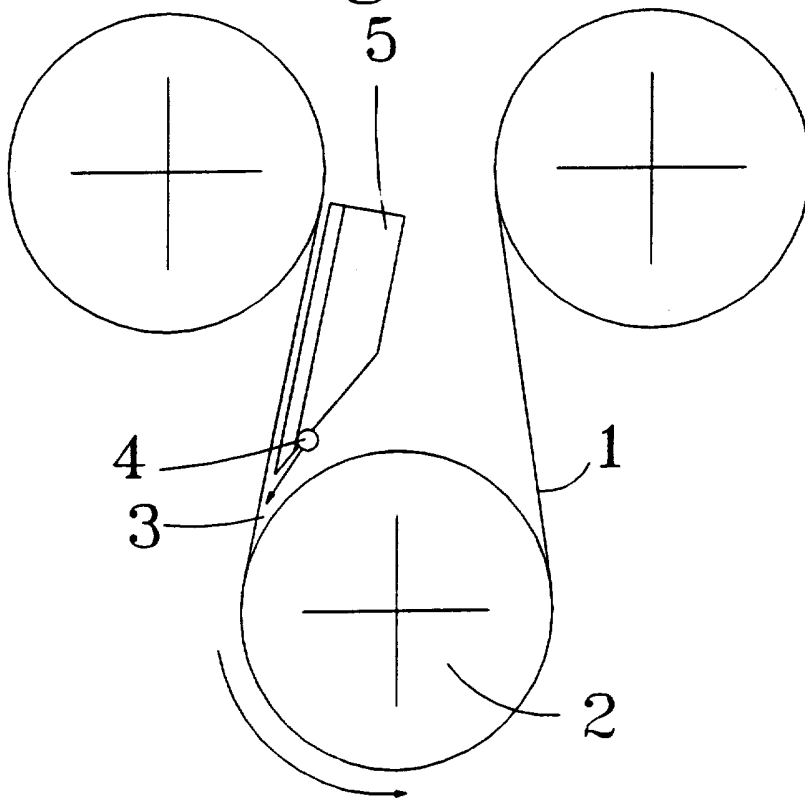

Fig. 2

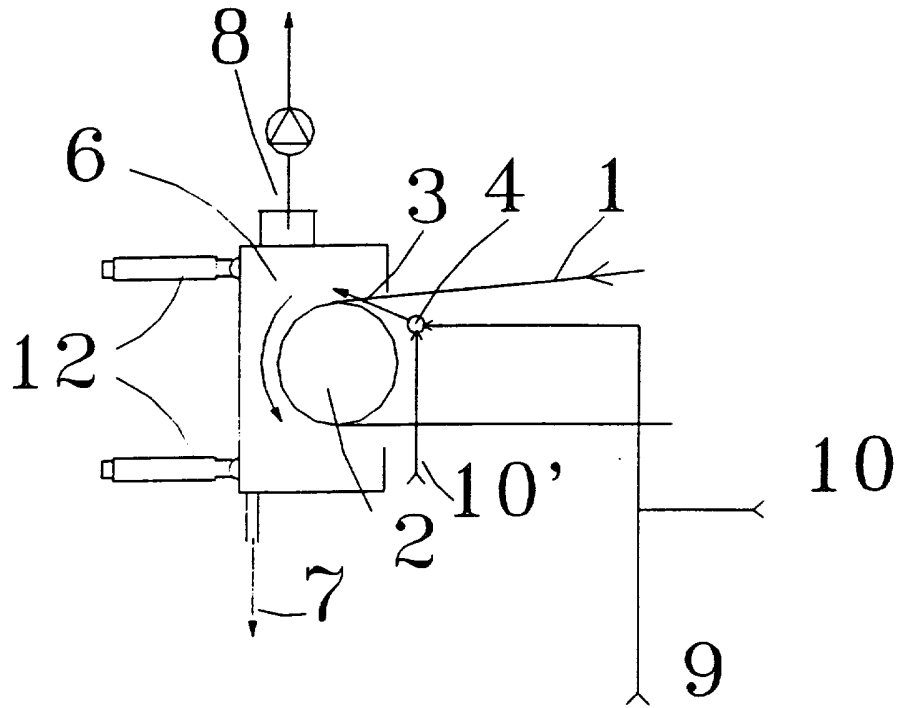

Fig. 3

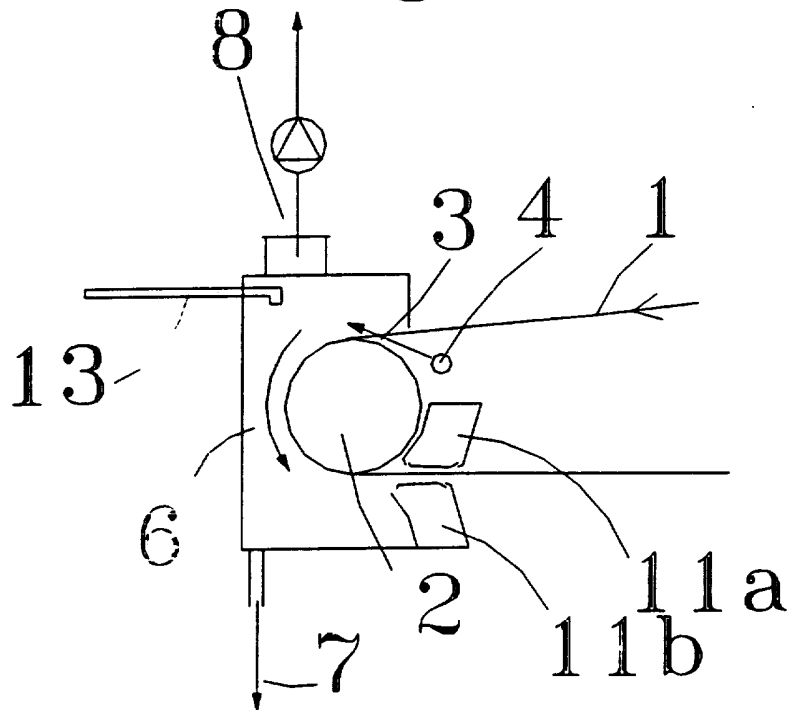

Fig. 4

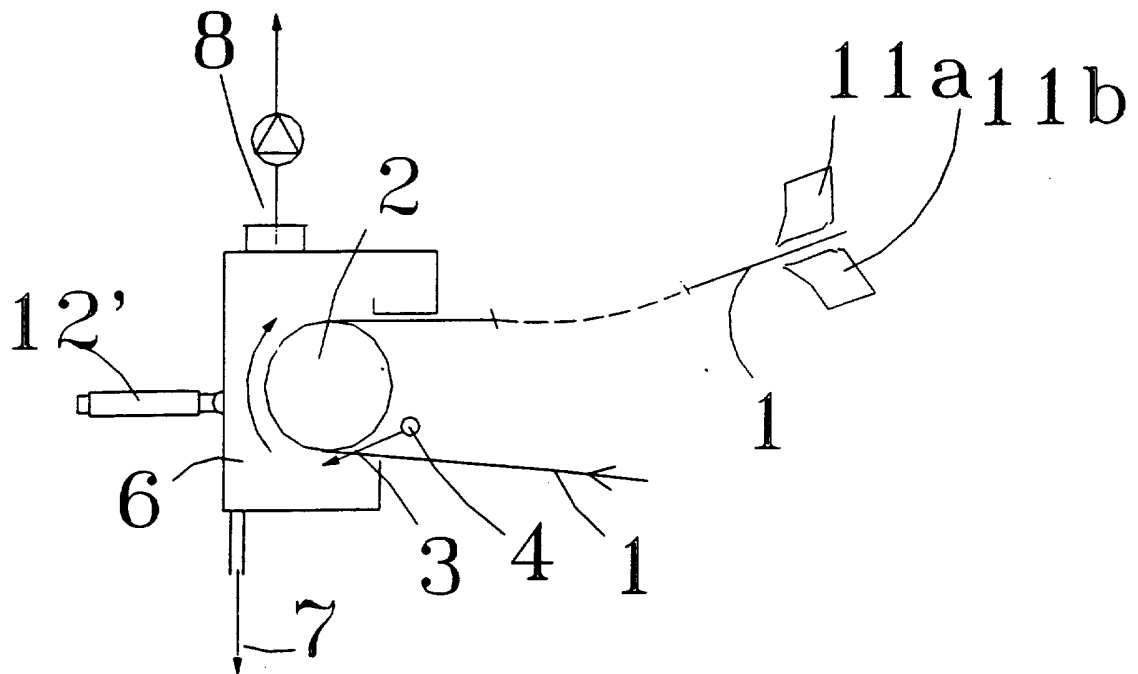

Fig. 5

INTERNATIONAL SEARCH REPORT

International application No.

PCT/FI 96/00044

A. CLASSIFICATION OF SUBJECT MATTER

IPC6: D21F 1/32

According to International Patent Classification (IPC) or to both national classification and IPC

B. FIELDS SEARCHED

Minimum documentation searched (classification system followed by classification symbols)

IPC6: D21F

Documentation searched other than minimum documentation to the extent that such documents are included in the fields searched

SE,DK,FI,NO classes as above

Electronic data base consulted during the international search (name of data base and, where practicable, search terms used)

C. DOCUMENTS CONSIDERED TO BE RELEVANT

Category*	Citation of document, with indication, where appropriate, of the relevant passages	Relevant to claim No.
X	EP 0024205 A1 (ALBANY INTERNATIONAL CORPORATION), 25 February 1981 (25.02.81), page 6, line 8 - line 10, figure 1 --	1,11
X	WO 9213132 A1 (J.M. VOITH GMBH), 6 August 1992 (06.08.92), page 4, line 30 - page 5, line 9, figure 2	1,2,5,11,13
A	-- -----	9,15

 Further documents are listed in the continuation of Box C. See patent family annex.

* Special categories of cited documents:

"A" document defining the general state of the art which is not considered to be of particular relevance

"E" earlier document but published on or after the international filing date

"L" document which may throw doubts on priority claim(s) or which is cited to establish the publication date of another citation or other special reason (as specified)

"O" document referring to an oral disclosure, use, exhibition or other means

"P" document published prior to the international filing date but later than the priority date claimed

"T" later document published after the international filing date or priority date and not in conflict with the application but cited to understand the principle or theory underlying the invention

"X" document of particular relevance: the claimed invention cannot be considered novel or cannot be considered to involve an inventive step when the document is taken alone

"Y" document of particular relevance: the claimed invention cannot be considered to involve an inventive step when the document is combined with one or more other such documents, such combination being obvious to a person skilled in the art

"&" document member of the same patent family

Date of the actual completion of the international search

9 May 1996

Date of mailing of the international search report

10 -05- 1996

Name and mailing address of the ISA/
Swedish Patent Office
Box 5055, S-102 42 STOCKHOLM
Facsimile No. +46 8 666 02 86

Authorized officer

Olov Jensen
Telephone No. +46 8 782 25 00

INTERNATIONAL SEARCH REPORT
Information on patent family members

01/04/96

International application No.
PCT/FI 96/00044

Patent document cited in search report	Publication date	Patent family member(s)	Publication date
EP-A1- 0024205	25/02/81	SE-T3- 0024205 AU-B,B- 536648 AU-A- 6138380 CA-A- 1143982 GB-A,B- 2061341	17/05/84 19/02/81 05/04/83 13/05/81
WO-A1- 9213132	06/08/92	CA-A- 2078574 DE-A,C- 4018074 DE-A- 4101350 EP-A,A- 0522093 JP-T- 5504604 US-A- 5381580	19/07/92 12/12/91 23/07/92 13/01/93 15/07/93 17/01/95