



(11) (21) (C) **2,215,257**
(22) 1997/09/11
(43) 1998/03/13
(45) 2000/01/18

(72) SUGA, Takashi, JP

(72) HAYASHI, Yoshihiko, JP

(72) YOSHINO, Ryouzou, JP

(72) NAGAI, Kenji, JP

(73) HITACHI, LTD., JP

(51) Int.Cl.⁶ H02J 17/00, G06K 1/12, G06K 19/00, G06K 17/00, G06K 9/00

(30) 1996/09/13 (8-243128) JP

(54) **SYSTEME DE TRANSMISSION D'ENERGIE, CARTE A
CIRCUIT INTEGRE ET SYSTEME DE COMMUNICATION
D'INFORMATION UTILISANT UNE CARTE A CIRCUIT
INTEGRE**

(54) **POWER TRANSMISSION SYSTEM, IC CARD AND
INFORMATION COMMUNICATION SYSTEM USING IC
CARD**

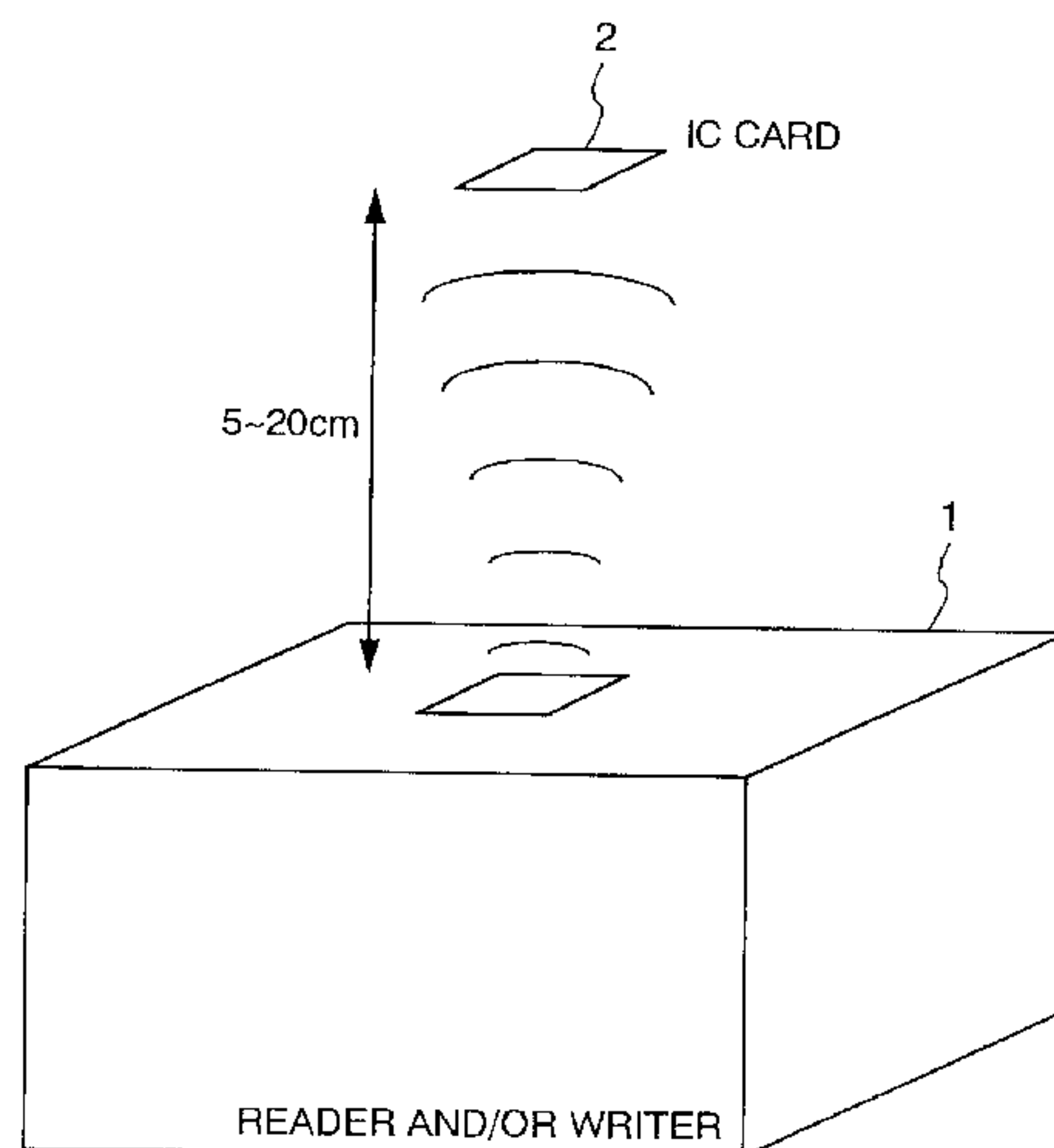

(57) La présente invention consiste en un système de transmission d'énergie, une carte à circuit intégré et un système de communication d'information utilisant une carte à circuit intégré. Dans le système de transmission d'énergie, l'énergie est transmise par radio du dispositif de transmission d'énergie à la carte à circuit intégré. Dans la carte à circuit intégré, l'énergie induite transmise est convertie en une tension c.c., l'énergie induite transmise ou une tension correspondant à l'énergie induite est détectée et une tension c.c. souhaitée à fournir au circuit interne est obtenue en commandant l'impédance en fonction de l'énergie induite détectée ou de la tension correspondant à l'énergie induite.

(57) The present invention comprises a power transmission system, an IC card, and an information communication system using an IC card. In the power transmission system, power is transmitted by radio from the power transmission device to the IC card. In the IC card, the transmitted induced power is converted into a DC voltage, the transmitted induced power or a voltage corresponding to the induced power is detected, and a desired DC voltage to be supplied to the internal circuit is obtained in controlling impedance based on the detected induced power or the voltage corresponding to the induced power.



- 64 -

ABSTRACT OF THE DISCLOSURE

The present invention comprises a power transmission system, an IC card, and an information communication system using an IC card.

In the power transmission system, power is transmitted by radio from the power transmission device to the IC card. In the IC card, the transmitted induced power is converted into a DC voltage, the transmitted induced power or a voltage corresponding to the induced power is detected, and a desired DC voltage to be supplied to the internal circuit is obtained in controlling impedance based on the detected induced power or the voltage corresponding to the induced power.

15

- 1 -

TITLE OF THE INVENTION

Power Transmission System, IC Card and Information
Communication System Using IC Card

5 BACKGROUND OF THE INVENTION

The present invention relates to a power
transmission system, an IC card and an information
communication system using an IC card, wherein commutation
tickets, railway tickets, bus tickets, etc. to be used at
10 wickets in railway stations or on buses will be replaced
with IC cards, and when an IC card is made to pass a
reader/writer, being provided at a wicket in a railway
station or on a bus, with noncontact or in close proximity
to it, power can be transmitted from the reader/writer to
15 the IC card by radio.

It has been known that power can be supplied to an
IC card from a power supply side by a noncontact method
using rays of light or magnetic fields.

When commutation tickets, railway tickets, bus
20 tickets, etc. to be used at wickets in railway stations or
on buses will be replaced with IC cards, and when a user
passes an IC card through a reader/writer provided at a
wicket in a railway station or on a bus with noncontact,
the distance between the IC card and the reader/writer may
25 vary much. When the reader/writer is so adjusted that

- 2 -

proper power can be transmitted from the reader/writer to the IC card when the distance between the IC card and the reader/writer is comparatively large, then in a case where the distance between the reader/writer and the IC card is small, excessive power may be transmitted from the reader/writer to the IC card, which may cause a malfunction or breakage of the IC card.

In other words, in the prior art, careful consideration was not given to a point that proper power shall be stably transmitted to an IC card from a reader/writer even though the distance between the IC card and the reader/writer may be largely varied.

Prior art in which it is intended to stably supply power from a reader/writer to an IC card even if the distance between the IC card and the reader/writer is largely varied is explained in Japanese Patents Laid-open No. Hei 7-85233 and Laid-open No. 9-62816.

In the Japanese Patent Laid-open No. 7-85233, following are described: among noncontact type data carriers of electromagnetic coupling system, in the case of movable equipment having a function to be able to receive data including a control signal from fixed equipment, a rectifier circuit composed of a rectifier D1 and a capacitor C2, and a variable resistor element composed of a transistor T2, resistor R3 and resistor R4 being controlled

- 3 -

by a DC voltage obtained from the rectifier circuit are
connected to a receiving coil of the data carrier in
parallel, and an excess power will be consumed in the
variable resistor elements. Further it is described in the
5 Japanese Patent Laid-open No. Hei 7-85233 that a signal
detector circuit composed of a rectifier D2, a resistor R1
and a capacitor C3 which detects an amplitude-modulated
wave superimposed on a AC voltage induced in the receiving
coil and transmits the detected data to a main circuit of
10 the data carrier as an input signal, and an amplitude
modulator circuit which receives the output signal of the
main circuit of the data carrier for switching a transistor
T1, and being composed of the transistor T1 which transmits
data from the data carrier to the fixed equipment, a
15 capacitor C4 and a resistor R2 are connected to the
receiving coil of the data carrier in parallel. In the
prior art as mentioned in the above, a resonant circuit is
not formed in the receiving coil of the data carrier, so
that in a case where the distance between the transmitting
20 coil on the fixed side and the receiving coil on the data
carrier side is large, an enough voltage is not induced in
the receiving coil and it is made difficult to obtain the
power required by the main circuit of the data carrier.
There is also another problem in the prior art. Since a
25 half-wave rectifier is adopted in the prior art, a large

- 4 -

ripple is produced, which requires a large smoothing capacity; therefore, it is made difficult to incorporate a capacitor of a large capacity in a data carrier in miniaturizing it.

5 It is described in the Japanese Patent Laid-open No. Hei 9-62816 that a receiving signal level of a resonance circuit of an antenna for transmitting and receiving data is detected and the quality factor Q of the antenna resonance circuit is varied by changing the
10 variable resistor element according to the detected voltage in order to adjust a receiving signal level to a desirable value.

In these prior art, since a variable resistor element is directly connected to a receiving antenna in
15 parallel, there is a problem in that the temperature rise in the variable resistor element is large and the size of a pressure protection circuit becomes large.

SUMMARY OF THE INVENTION

20 The purpose of the present invention is to solve the above-mentioned problems and offer an IC card and a power transmission system by radio in which it is made possible to stably supply power by radio from a reader/
writer to the internal circuit of an IC card in
25 miniaturizing the elements of a pressure protection circuit

- 5 -

and decreasing the temperature rise in a variable impedance circuit provided in an IC card even though the distance between the IC card and the reader/writer may be largely varied.

5 Another object of the present invention is to offer an IC card and a power transmission system by radio in which the power can be stably supplied to the internal circuit of the IC card by radio from a reader and/or writer by only making the IC card pass the reader and/or writer
10 with noncontact or in close proximity to it by improving the responsibility of the system in miniaturizing the elements in a pressure protection circuit and decreasing the temperature rise in a variable impedance circuit.

 A further object of the present invention is to
15 offer an IC card and an information communication system using an IC card in which it is made possible to supply power stably from a reader and/or writer to the IC card with noncontact in miniaturizing the elements in the pressure protection circuit and decreasing the temperature
20 rise in the variable impedance circuit provided in the IC card and to perform information communication with high reliability between the reader and/or writer and the IC card.

 Yet another object of the present invention is to
25 offer a power transmission system by radio, an IC card and

- 6 -

an information communication system using the IC card. In
the power transmission system by radio it is so arranged
that power can be stably supplied even when the distance
between an IC card and a reader/writer is largely varied in
5 decreasing the temperature rise in the variable impedance
circuit by controlling the static capacity for the induced
power received on the IC card side.

A still further object of the present invention is
to offer a power transmission system by radio, an IC card
10 and an information communication system using the IC card.
In the power transmission system by radio it is so arranged
that proper power can be stably supplied to the IC card by
radio from the power transmission portion of the reader/
writer by only passing the IC card through the reader/
15 writer with noncontact or in proximity to it and
information can be communicated between the reader/writer
and the IC card with high reliability.

In order to achieve the above-mentioned objects,
the present invention is a power transmission system in
20 which power is transmitted by radio from a power
transmitting device (reader and/or writer device) to an IC
card. The IC card comprises: an antenna having a resonance
circuit for receiving the transmitted radio wave, a full
wave rectifier circuit for rectifying an induced power
25 received by the antenna, a power supply circuit which

- 7 -

converts a DC voltage output from the full wave rectifier circuit into a power supply voltage, a detector circuit which detects the DC voltage output from the full wave rectifier circuit, an impedance control circuit portion
5 which produces a desired power supply voltage from the DC voltage detected in the detector circuit by controlling the impedance of the circuit, and an internal circuit to be supplied with the desired power supply voltage obtained from the impedance control circuit.

10 The present invention is also a power transmission system in which power is transmitted by radio from a power transmission device to an IC card, wherein the IC card comprises: a receiving portion which receives the transmitted radio wave and produces induced power, a
15 rectifier circuit portion which converts the induced power in the receiving portion into a DC voltage, a variable impedance circuit portion in which the DC voltage obtained in the rectifier circuit is controlled by varying the impedance of the circuit based on the induced power
20 detected in the detector circuit portion or a voltage corresponding to the induced power, and an internal circuit to be supplied with a controlled DC voltage from the variable impedance control circuit.

25 The present invention is also a power transmission system in which power is transmitted by radio from the

- 8 -

power transmission device to an IC card. In the IC card,
the transmitted induced power is converted into a DC
voltage, the transmitted induced power or a voltage
corresponding to the induced power is detected, and a power
5 supply voltage of a desired DC voltage to be supplied to
the internal circuit is obtained by controlling a static
capacity based on the detected induced power or a voltage
corresponding to the induced power.

The present invention is a power transmission
10 system in which power is transmitted by radio from a power
transmission device to an IC card. The IC card comprises:
a rectifier circuit which converts the transmitted induced
power into a DC voltage, an internal circuit to be supplied
with the DC voltage obtained from the rectifier circuit, a
15 detector circuit which detects the transmitted induced
power or a voltage corresponding to the induced power, and
a static capacity control circuit which obtains a power
supply voltage of a desired DC voltage to be supplied to
the internal circuit by controlling the static capacity
20 based on the induced voltage or a voltage corresponding to
the induced power which is detected in the detector
circuit.

The present invention is a power transmission
system in which power is transmitted by radio from a power
25 transmitting device to an IC card. The IC card comprises

- 9 -

the functions as shown below: the transmitted induced power is converted into a DC voltage to be supplied to an internal circuit, the transmitted induced power or a voltage corresponding to the induced power is detected, and the information about the detected induced power or a voltage corresponding to the induced power is transmitted by radio to the power transmitting device. The power transmitted from the power transmitting device is controlled based on the above-mentioned transmitted information.

The present invention is a power transmission system in which power is transmitted by radio from a power transmitting device to an IC card. The IC card comprises the function to convert the transmitted induced power into a DC voltage and to supply the DC voltage to the internal circuit, and also to detect the information concerning the relative position of the IC card to that of the power transmitting device. The power transmitted from the power transmission device is controlled based on the above-mentioned detected information.

The present invention is a power transmission system in which power is transmitted by radio from a power transmitting device to an IC card. The IC card comprises the function to convert the transmitted induced power into a DC voltage and to supply the DC voltage to the internal

- 10 -

circuit and to detect the information concerning the relative position of the IC card to that of the power transmitting device. A desired DC voltage can be obtained in controlling the impedance of a circuit in the IC card
5 based on the detected information.

The present invention is an IC card which comprises: an antenna having a resonance circuit for receiving a transmitted radio wave, a full wave rectifier circuit for rectifying an induced power received with the
10 antenna, a power supply circuit for converting the DC voltage obtained from the full wave rectifier circuit into a power supply voltage, a detector circuit for detecting the DC voltage rectified in the full wave rectifier circuit, an impedance control circuit which controls the
15 impedance of the circuit for making the detected DC voltage a desired DC voltage and making the power supply voltage converted in the power supply circuit a desired power supply voltage, and an internal circuit to be supplied with the desired power supply voltage obtained from the
20 impedance control circuit portion.

The present invention is an IC card which comprises: a receiver portion which receives a radio wave to produce an induced power, a rectifier circuit portion for rectifying the induced power generated in the receiver
25 portion to convert the induced power to a DC voltage, a

- 11 -

detector circuit portion which detects an induced power
obtained in the receiver portion or a voltage corresponding
to the induced power, a variable impedance control circuit
portion which controls the DC voltage obtained from the
5 rectifier circuit portion based on the induced power
detected in the detector circuit portion or a voltage
corresponding to the induced power, and an internal circuit
to be supplied with a controlled DC voltage from the
variable impedance control circuit portion.

10 The present invention comprises an IC card in which
an impedance in the variable impedance circuit portion is
formed with a resistor.

 The present invention is an IC card in which the
full wave rectifier circuit, the power supply circuit, the
15 detector circuit, the impedance control circuit, and the
internal circuit are composed with one chip.

 The present invention is an IC card which
comprises: a receiver portion which receives an induced
power by radio, a rectifier circuit portion which rectifies
20 the induced power received in the receiver portion to
convert it into a DC voltage, a detector circuit portion
which detects the induced power obtained from the receiver
portion or a voltage corresponding to the induced power, a
static capacity control circuit portion which obtains a
25 desired DC voltage from the rectifier circuit portion by

- 12 -

controlling the static capacity based on the induced power detected in the detector circuit portion or a voltage corresponding to the induced power, and an internal circuit which is supplied with a DC voltage from the rectifier circuit portion being controlled by the static capacity control circuit portion.

The present invention is an information communication system using an IC card which comprises a reader and/or writer device (unit) having an information communication portion and a power transmitting portion and power is transmitted by radio from the power transmitting portion to an IC card.

The IC card comprises: a rectifier circuit portion which rectifies the induced power transmitted from the reader and/or writer to convert the induced power into a DC voltage, a detector circuit portion which detects the induced power obtained from the receiver portion or a voltage corresponding to the induced power, a variable impedance control circuit portion which controls the impedance of the circuit according to the DC voltage obtained from the rectifier circuit portion based on the induced power detected in the detector circuit portion or a voltage corresponding to the induced power, and an internal circuit which obtains a desired DC voltage from the variable impedance control circuit. The information

- 13 -

communication system is so designed that an information communication can be performed using a radio wave between the internal circuit of the IC card and the information communication portion of the reader and/or writer device.

5 transmitted to the IC card or a voltage corresponding to the induced power is detected, and a desired DC voltage is obtained in controlling the impedance base on the detected induced power or a voltage corresponding to the induced power and the desired DC
10 voltage is supplied to the internal circuit. The present invention is so constituted that it is possible to perform information communication by radio between the internal circuit of the IC card and the information communication portion of the reader and/or writer device.

15 The present invention is an information communication system using an IC card, which comprises reader and/or writer device having an information communication portion and a power transmission portion and power is transmitted by radio from the power transmitter
20 portion to the IC card by radio. The IC card comprises: an antenna having a resonance circuit for receiving a radio wave transmitted from the reader and/or writer device, a full wave rectifier circuit for rectifying the induced power received in the antenna, a power supply circuit which
25 converts the DC voltage rectified in the full wave

- 14 -

rectifier circuit into a power supply voltage, a detector
circuit which detects the DC voltage rectified in the full
wave rectifier circuit, an impedance control circuit which
controls the impedance of the circuit to make a detected DC
5 voltage detected in the detector circuit a desired DC
voltage and to make the power supply voltage converted in
the power supply circuit a desired power supply voltage,
and an internal circuit to be supplied with the desired
power supply voltage obtained from the impedance control
10 circuit.

The information communication system is so designed
that the information communication can be performed by a
radio wave between the internal circuit of the IC card and
the information communication portion of the reader and/or
15 writer device.

The present invention is an information
communication system using an IC card which comprises a
reader and/or writer device having an information
communication portion and a power transmission portion
20 which transmits power from the power transmission portion
to the IC card by radio. In the IC card, following
operations are performed: the induced power transmitted
from the reader and/or writer device is converted into a DC
voltage and it is supplied to the internal circuit, the
25 induced power transmitted to the IC card or a voltage

- 15 -

corresponding to the induced power is detected, and the information concerning the detected induced power or the voltage corresponding to the induced power is transmitted to the power transmission portion of the reader and/or
5 writer device by radio. The reader and/or writer controls the power to be transmitted from the power transmission portion based on the information sent from the IC card. The information communication system is so designed that information communication can be performed between the
10 internal circuit of the IC card and the information communication portion of the reader and/or writer device.

The present invention is an information communication system using an IC card, wherein the transmission of power by radio from the reader and/or
15 writer to the IC card and the communication of information by radio between the internal circuit of the IC card and the information communication portion of the reader and/or writer device are performed with a common antenna.

The present invention is an information
20 communication system, using an IC card, wherein the reader and/or writer device comprises: a power supply portion which generates a signal to be used for the transmission of power, an encoder circuit for encoding input data for transmission, a modulator which executes amplitude
25 modulation of a signal obtained from the encoder circuit

- 16 -

and superimposes it on the signal obtained from the power supply portion, a feeder circuit for feeding power based on the signal obtained from the modulator, and an antenna for generating a radio wave corresponding to the fed current by
5 the feeder circuit.

The present invention is an information communication system using an IC card, wherein the internal circuit of the IC card comprises: a decoder circuit which performs waveform shaping and decodes a modulated wave for
10 communication detected by the antenna, a microcomputer which inputs received data decoded in the decoder circuit and outputs transmission data, an encoder circuit which encodes the transmitting data output from the microcomputer, and a modulator which modulates a signal and
15 inputs it to the antenna based on the signal encoded in the encoder circuit.

As explained in the above, according to the above-mentioned constitution, it is made possible to realize a power transmission system by radio and an IC card, wherein
20 even though the distance between the IC card and the reader and/or writer device (power transmitting device) is largely varied, power can be stably transmitted by radio from the reader and/or writer device to the internal circuit of the IC card in miniaturizing a pressure protection circuit
25 provided in the IC card and decreasing the temperature rise

- 17 -

in a variable impedance circuit. In particular, the realization of miniaturization of the elements of the pressure protection circuit and the low temperature rise in the variable impedance circuit made it possible to
5 constitute an IC card with an antenna for receiving a radio wave and elements of one-chip constitution, which caused to realize a low cost IC card.

According to the above-mentioned constitution, a power transmission system by radio and an IC card can be
10 realized, wherein power can be transmitted from the reader and/or writer device to the IC card by radio using a coil-shaped antenna or a spiral antenna on the IC card, and power can be supplied stably by radio from the reader and/or writer device to the internal circuit of the IC card
15 by only making an IC card pass the reader and/or writer device with noncontact or in the proximity to it in miniaturizing the elements in the pressure protection circuit, decreasing the temperature rise in the variable impedance circuit, and improving the responsibility of the
20 circuit.

According to the above-mentioned constitution, a power transmission system by radio, an IC card, and an information communication system using an IC card can be realized, wherein power can be stably supplied to the IC
25 card even though the distance between the IC card and the

- 18 -

reader and/or writer is largely varied in decreasing the
temperature rise in the variable impedance circuit by
controlling the induced power received on the side of the
IC card by varying the static capacity in the variable
5 impedance circuit.

According to the above-mentioned constitution, a
power transmission system by radio, an IC card, and an
information communication system using the IC card can be
realized, wherein proper power can be transmitted from the
10 power transmission portion of the reader and/or writer
device to the IC card by radio by only
making the IC card pass the reader and/or writer with
noncontact or in proximity to it. Thus, power is stably
supplied to the internal circuit of the IC card, and the
15 communication of information of high reliability can be
performed between the reader and/or writer device and the
IC card.

According to the above-mentioned constitution, an
information communication system using an IC card can be
20 realized, wherein power is stably supplied from the reader
and/or writer to the IC card with noncontact, and the
communication (transmission and reception) of information
of high reliability can be performed between the reader
and/or writer device and the IC card.

25

- 19 -

BRIEF DESCRIPTION OF THE DRAWINGS

Fig. 1 shows a schematic of a power transmission system according to the present invention, in which power is transmitted by radio from a reader and/or writer device provided at a wicket in a railway station or on a bus to an IC card which is passed the reader and/or writer device with noncontact or in proximity to it;

Fig, 2 shows a power transmission system by radio according to the present invention;

Fig. 3 shows the relation between d and V_L , where d denotes the distance between a coil of a power supply circuit provided in a reader and/or writer and an IC card, and V_L denotes an induced voltage V_L obtained from an rectifier circuit;

Fig. 4 shows a schematic of a first embodiment of the power transmission system by radio according to the present invention;

Fig, 5 shows a schematic of a second embodiment of a power transmission system by radio according to the present invention;

Fig. 6 shows a concrete form of the variable impedance circuit 30 shown in Fig. 4 in the first embodiment;

Fig. 7 shows a state where an induced voltage is controlled within an allowable range owing to impedance

- 20 -

control;

Figs. 8(a) and 8(b) show a concrete form of the variable impedance circuit 30 shown in Fig. 4 in the second embodiment;

5 Figs. 9(a) and 8(b) show a concrete form of the variable impedance circuit 30 shown in Fig. 4 in a third embodiment;

10 Fig. 10 shows a schematic view of a power transmission control system by radio in the third embodiment according to the present invention;

Fig. 11 shows a schematic view of a power transmission control system by radio in a fourth embodiment according to the present invention;

15 Fig. 12 shows a schematic view of the whole of the present invention including the part in which an IC card functions the roles of railway tickets, commutation tickets, etc. in transmitting or receiving the information concerning railway tickets, commutation tickets, etc. by radio in the first embodiment;

20 Fig. 13 shows a plan view showing the mounted state of elements on an IC card according to the present invention;

25 Fig. 14 shows a schematic view of the whole of the present invention including the part in which an IC card functions the roles of railway tickets, commutation

- 21 -

tickets, etc. in transmitting or receiving the information concerning railway tickets, commutation tickets, etc. by radio in the second embodiment; and

Fig. 15 shows the relation between the power transmitting wave and the modulated wave for the data communication according to the present invention.

DETAILED DESCRIPTION OF THE PREFERRED EMBODIMENTS

In the following, the forms of embodiments of a power transmission system by radio and an IC card according to the present invention will be explained referring to the drawings.

Fig. 1 is a schematic view of a power transmission system according to the present invention in which power is transmitted by radio from a reader and/or writer 1 provided at a wicket in a railway station or on a bus to an IC card 2 which is to be passed the reader and/or writer 1 with noncontact or in proximity to it. The IC card 2 is passed the reader and/or writer 1 provided at the wicket in a railway station or on a bus by an user with noncontact, at a distance of about 5 to 20 cm. In that case, the information concerning railway tickets, commutation tickets, etc. is communicated by radio between the reader and/or writer and the IC card; thereby, the IC card will be able to perform the role of a railway ticket, commutation

- 22 -

ticket, or the like.

Fig. 2 shows a schematic view of a power transmission system by radio according to the present invention. A reference numeral 21 denotes a power supply circuit in the reader and/or writer 1 provided at a wicket in a railway station or on a bus. The power supply circuit 21 comprises: a power supply 22 which generates a high frequency voltage of 13.56 MHz, an impedance matching circuit 23 which prevents reflection at a junction point, and a coil 24 which transmits power of about 2 to 5 W of 13.56 MHz by radio. The IC card comprises an induced voltage generator portion 28 which is composed of a coil 26 which receives power by radio from the power supply circuit 21 provided in the reader and/or writer and a rectifier circuit 27 which converts the high frequency power received by the coil 26 into a DC voltage of the order of 7 to 15 V, and an internal circuit 29 (constituted with an IC chip, for example) which is operated with a DC voltage of the order of 7 to 10 V generated in the induced voltage generator portion 28.

In order to be able to supply a desired DC voltage to the internal circuit 29, even though the distance between the IC card 2 and the reader and/or writer 1 may be extremely large, a resonance circuit with a tuning capacitor 25 is provided in the coil 26 to be able to

- 23 -

obtain a large induced voltage. The coil 26 has a multilayer structure of more than 2 layers in which a spiral-shaped antenna coil is wound continuously in the same direction, so that stray capacitance between windings and the inductance of the coil may constitute a resonance circuit. As a result, a tuning capacitor 25 may not be needed or an extremely small one will do the work.

In order to transmit power by radio, a coil (a coil-shaped or spiral-shaped antenna) 24 and a coil (a coil-shaped or spiral-shaped antenna) 26 are used for the purpose of improving the responsibility of the system to be able to supplying power to the internal circuit (constituted with an IC chip, for example) of the IC card 2 in less than 0.1 sec. It has a merit to improve the strength of the IC card 2 against deformation by forming the coil 26 on the IC card 2. Therefore, if it is possible to transmit power to the internal circuit 29 of the IC card 2 in less than 0.1 sec., a light emitting element and a light receiving element can be used in place of the coils 24 and 26.

Fig. 3 shows the relation between d and V_L , where d denotes the distance between the coil 24 of the power supply circuit 21 provided in a reader and/or writer 1 and the IC card 25, and V_L denotes the induced voltage obtained from the rectifier circuit 27. As shown in Fig. 3, in the

- 24 -

case where the system is so designed that when the distance
d between the coil 24 of the power supply circuit 21 and
the IC card 25 is at its maximum value d_2 of about 20 cm,
the allowable minimum voltage V_{min} of about 2 to 4 V can be
5 obtained, when the distance d between the coil 24 of the
power supply circuit 21 is at its minimum value d_1 of about
5 cm, the induced voltage V_L becomes the order of 40 V
which largely exceeds the allowable maximum voltage V_{max}
which may cause malfunction in the internal circuit 29 or
10 breakage of it.

Accordingly in the present invention, the induced
voltage V_L obtained from the rectifier circuit 27 shall be
constantly controlled to be in the allowable range of the
induced voltage, from V_{min} to V_{max} , even when an IC card is
15 passed the reader and/or writer 1 with noncontact at a
distance of about 5 to 20 cm.

In the next step, the form of a first embodiment of
a power transmission system by radio according to the
present invention will be explained referring to Fig. 4.
20 Fig. 4 shows a schematic view showing the form of the first
embodiment of the power transmission control system by
radio according to the present invention. The power supply
circuit 21 provided in the reader and/or writer 1 has the
same constitution as that shown in Fig. 2. An induced
25 voltage generator portion 28a is composed of the coil 26

- 25 -

and the rectifier 27 shown in Fig. 2 added with the following circuits: a variable impedance circuit 30 which supplies a controlled high frequency power to the rectifier circuit 27 in controlling the high frequency power obtained from the coil 26 by varying its impedance, a voltage detector circuit 31 which detects the induced voltage V_L obtained from the rectifier circuit 27, and a control circuit 32 which controls the variable impedance circuit 30 by varying its impedance based on the induced voltage detected in the induced voltage detector circuit 31. The internal circuit 29 in the IC card 2 is the same as that shown in Fig. 2. The voltage detector circuit 31, as shown by a chain line, can be a circuit which calculates the mean value of induced voltages by detecting a high frequency power (a high frequency voltage) obtained from the variable impedance circuit 30, for example.

In an arrangement as shown in the above, the voltage detector circuit detects the induced voltage V_L obtained from the reifier circuit 27 and when it detects a voltage which deviates out of the allowable induced voltage range V_{min} to V_{max} , the impedance of the variable impedance circuit 30 is controlled by the control circuit 32, and the high frequency power obtained from the coil 26 is supplied to the rectifier circuit 27 being controlled to be a proper value; thereby, a voltage which is constantly kept in the

- 26 -

allowable induced voltage range can be obtained from the
rectifier circuit 27. In the result, even when the
distance between the reader and/or writer 1 and the IC card
2 approaches 5 cm, it is possible to supply a voltage in
5 the allowable range of the induced voltage to the internal
circuit 29. In the above, it is possible to constitute the
rectifier circuit 27 and the internal circuit 29 with one
IC chip.

In the next step, a second embodiment of the power
10 transmission control system by radio according to the
present invention will be explained referring to Fig. 5.
Fig. 5 shows a schematic view of the second embodiment of
the power transmission control system according to the
present invention. In the second embodiment shown in Fig.
15 5, a different point from the first embodiment shown in
Fig. 4 is in that the variable impedance circuit 30 is
provided following the rectifier circuit 27. The
constitution of the power supply circuit 21 provided in the
reader and/or writer is the same as that shown in Fig. 2.
20 The induced voltage generator portion 28a in the IC card 2
is composed of a rectifier circuit 27 which converts the
high frequency power obtained from the coil 26 into a DC
voltage VL, a voltage detector circuit 31 which detects the
DC voltage VL obtained from the rectifier circuit 27, a
25 variable impedance circuit 30 which supplies a controlled

- 27 -

DC voltage to the internal circuit 29, the controlled DC voltage which is obtained from the DC voltage output from the rectifier circuit 27 being controlled by varying its impedance based on the induced voltage detected by the voltage detector circuit 31, and the control circuit 32 which controls the impedance of the variable impedance circuit 30 to vary. The internal circuit 29 in the IC card 2 is the same as that shown in Fig. 2.

In the arrangement as mentioned in the above, the voltage detector circuit 31 detects the rectified induced voltage VL obtained from the rectifier circuit 27 and when it is detected that the voltage deviates out of the allowable induced voltage range, Vmin to Vmax, the impedance of the variable impedance circuit is controlled by the control circuit 32 to correct the deviation, thus a DC voltage obtained from the rectifier circuit 27 is controlled and supplied to the internal circuit 29; thereby, a voltage in the range of allowable induced voltage can be constantly obtained from the rectifier 27. In the result, even when the distance between the reader and/or writer 1 and the IC card 2 approaches 5 cm it is possible to supply a voltage in the allowable range to the internal circuit 29.

Fig. 6 shows a concrete form of the variable impedance circuit 30 shown in Fig. 4 in the first

- 28 -

embodiment. In the variable impedance circuit, there are two circuit elements, an resistor R1 and an electron switch 1 connected in series and an resistor R2 and an electron switch 2 connected in series, and a coil 26 is connected with both above-mentioned circuit elements in parallel, which constitutes the variable impedance circuit 30. The ON-OFF operations of these electron switches, S1 and S2, are controlled by control signals from the control circuit 32. As shown in Fig. 7, when the distance between the coil 24 of the power supply circuit 21 and the coil 26 of the IC card 2 being denoted by d decreases to a smaller one being off from d_2 , a large value of d , and the rectified induced voltage V_L exceeds V_{max} , at first, the electron switch S1 is made ON in the state where the electron switch S2 is kept OFF by a control signal from the control circuit 32, then the resistor R1 is connected and the induced voltage V_L is lowered to the V_{min} . When the coil 26 of the IC card 2 further approaches the coil 24 of the power supply circuit and the induced voltage V_L exceeds the V_{max} again, the electron switch S2 is made ON in the state where the electron switch S1 is kept ON, then both resistors R1 and R2 are connected and the rectified induced voltage V_L is lowered to the V_{min} ; therefore, even when the distance between the coil 26 of the IC card and the coil 24 of the power supply circuit is decreased to d_1 , it will be

- 29 -

possible to keep the voltage VL not to exceed the Vmax. The allowable range between the Vmin and Vmax can be made narrower by increasing the number of resistors. As mentioned in the above, when the variable impedance circuit 5 30 is constituted with a circuit in which a resistor R1 and an electron switch S1 are connected in series and also a resistor R2 and an electron switch S2 are connected in series, and both circuit elements are connected to the coil 26 in parallel, the variable impedance circuit 30 can be an 10 excellent circuit in responsibility. The variable impedance circuit 30 mentioned in the above can be applied to the variable impedance circuit 30 composed of a variable resistor element shown in Fig. 5. In particular as shown in Fig. 14, a variable impedance circuit 30 is provided 15 next to a constant voltage power supply circuit 204 which is provided following a rectifier circuit 27 (203), which makes it possible to miniaturize the elements in the pressure protection circuit 30. Owing to it, a wireless chip 202 can be constituted small and in the result, it is 20 made possible to cut down the cost of the IC card, not only that of the chip.

Fig. 8(a) shows a concrete form of the variable impedance circuit 30 shown in Fig. 4 in the second embodiment 2. The variable impedance circuit 30 is 25 constituted with the circuit elements as described below: 2

- 30 -

circuit elements, a capacitor C1 and an electron switch S1 being connected in series, and a capacitor C2 and an electron switch S2 being connected in series, are connected to the coil 26 in parallel. These electron switches, S1 and S2, are ON-OFF controlled by a control signal from the control circuit 32. In the constitution as mentioned in the above, in the same way as the first embodiment shown in Fig. 5, it is possible to control the rectified induced voltage VL obtained from the rectifier circuit 27 to be in the allowable voltage range, from Vmin to Vmax, even when the coil 26 on the IC card 2 is made to be in a close proximity to the coil 24 of the power supply circuit 21, which will be understood from the relation shown in Fig. 7(b). In the case of the second embodiment, in comparison with the case of the first embodiment, the temperature rise can be controlled to be low, which means the upgrade in reliability. In order to realize the second embodiment, however, it is indispensable to have a technology of manufacturing a variable capacitor of a miniature size.

Fig 9 shows a concrete form of the variable impedance circuit 30 shown in Fig. 4 in a third embodiment. The variable impedance circuit 30 is constituted as shown in the following: terminals, T1, T2 and T3 are formed corresponding the length of the coil 26 and an electron switch St which is able to change over the connection to

- 31 -

T1, T2 or T3 is provided, the switch St which can be changed over by a control signal from the control circuit 32. In the constitution as mentioned in the above, it is also possible to vary the high frequency power induced in the coil 26; therefore, it is also made possible to control the rectified induced voltage VL obtained from the rectifier circuit 27 to be in the allowable voltage range even when the coil 26 on the IC card 2 made to be in a close proximity to the coil 24 of the power supply circuit 21.

In the next step, a third embodiment of the power transmission control system by radio according to the present invention will be explained referring to Fig. 10.

Fig. 10 shows a schematic view of a power transmission control system by radio in a third embodiment according to the present invention. The power supply circuit 21 provided in the reader and/or writer 1 comprises: a control power supply 22a which generates a high frequency voltage of 13.56 MHz of a variable voltage, a matching circuit 23 for impedance matching, a coil 24 for transmitting a radio wave of 13.56 MHz in a power level of approximately 2 to 5 W, a receiving coil (coil-shaped, or spiral-shaped antenna) 37 and a receiving circuit 38 for receiving a radio signal concerning an induced voltage transmitted from the IC card 2, and a control circuit 39

- 32 -

which controls the high frequency voltage output from the control power supply 22a based on the induced voltage value received in the receiving circuit 38. The induced voltage generator portion 28b on the IC card 2 is composed of a coil 26, a rectifier circuit 27 shown in Fig. 2 and the circuits as shown in the following: a voltage detector circuit 31 which detects a rectified induced voltage VL obtained from the rectifier circuit 27, a transmitting circuit 35 for transmitting a signal concerning the value of an induced voltage detected in the voltage detector circuit 31 to the coil 37 of the power supply circuit 21a by a radio wave, and a coil (coil-shaped or spiral-shaped antenna) 36. The internal circuit 29 on the IC card 2 is the same as that shown in Fig. 2.

In the constitution as mentioned in the above, the voltage detector circuit 31 detects a rectified induced voltage VL obtained from the rectifier circuit 27, a signal concerning the detected induced voltage value is transmitted to the coil 37 of the power supply circuit 21a by the transmitting circuit 35 and the coil 36 by radio to be received by the coil 37 and receiving circuit 38.

The control circuit 39 detects the deviation of the rectified induced voltage VL out of the allowable range of the rectified induced voltage value, from V_{min} to V_{max} , base on the signal of the rectified induced voltage value

- 33 -

received in the receiving circuit 38 and controls the high frequency voltage of the control power supply 22a, and the controlled high frequency power transmitted from the coil 24 to the coil 26 is supplied to the rectifier circuit 27; therefore, a voltage with a value in the range of allowable induced voltage value can be constantly obtained from the rectifier circuit 27. In the result, even when the distance between the reader and/or writer 1 and the IC card 2 approaches to the order of 5 cm, it is possible to supply a voltage in the allowable range to the internal circuit 29.

In the next step, a fourth embodiment of the power transmission control system by radio according to the present invention will be explained referring to Fig. 11. Fig. 11 shows a schematic view of a fifth embodiment of the power transmission control system by radio according to the present invention. The power supply circuit 21b provided in the reader and/or writer 1 comprises: a control power supply 22a which generates a high frequency variable voltage of 13.56 MHz, a matching circuit 23 for impedance matching, a coil 24 for transmitting high frequency power having the frequency of 13.56 MHz and power level of about 2 to 5 W, a sensor circuit 41 which detects an instantaneous distance from a passing IC card 2 using infrared rays or ultrasonic waves, a position detector

- 34 -

circuit 42 which calculates an instantaneous distance
(position) from a passing IC card 2 using a signal obtained
from the sensor circuit 41, and a control circuit 39 which
controls the high frequency voltage of the control power
supply 22a based on the information of an instantaneous
5 distance d (position) from an passing IC card 2 detected in
the position detector circuit 42. The induced voltage
generator portion 28 on the IC card 2 is composed of the
coil 26 and the rectifier circuit 27 shown in Fig. 2.

10 In the constitution as mentioned in the above, it
is possible to constantly obtain a voltage which is in the
allowable range of the rectified induced voltage value from
the rectifier circuit 27 by an arrangement as shown in the
following: the sensor circuit 41 detects the instantaneous
15 distance from a passing IC card 2 using infrared rays or
ultrasonic waves, with the detected signal, the position
detector circuit 42 calculates an instantaneous distance
(position) from the passing IC card 2, the control circuit
39 calculates a high frequency voltage value to be
20 generated from the control power supply 22a from the
relation between the distance d and the rectified induced
voltage V_L shown in Fig. 3 based on the information of an
instantaneous distance (position) d from the IC card 2
calculated in the position detector circuit 42, and
25 controls to generate the calculated high frequency voltage

- 35 -

value from the control power supply 22a, and also controls the high frequency power to be transmitted from the coil 24 to the coil 26 to supply the controlled power to the rectifier circuit 27. In the result, even when the
5 distance between the reader and/or writer 1 and the IC card 2 approaches to about 5 cm, it is made possible to supply a voltage in the allowable range to the internal circuit 29.

In the next step, the whole of the system according to the present invention including the part in which the
10 information concerning railway tickets or commutation tickets is communicated by radio and an IC card performs the role of a railway ticket or commutation ticket will be explained in the following. Fig. 12 shows a schematic view of a first embodiment concerning the whole system including
15 the part in which the information concerning railway tickets or commutation tickets is communicated by radio and an IC card performs the role of a railway tickets or commutation ticket.

The reader and/or writer 1 comprises, besides the
20 power supply circuit 21, an information transmitter-receiver portion 51 which communicates with the IC card 2 about the information by radio. The information transmitter-receiver portion 51 is connected to a communication network and a mechanism to open or close a
25 wicket door or a display device, and outputs data to be

- 36 -

transmitted to the IC card 2 to a modulator portion 54 and is composed of the following: a CPU 52 which processes data obtained from a demodulator portion 55 and outputs them, a memory 53 which stores data or processing program data
5 obtained from the IC card 2, a modulator portion 54 which modulates the data from the CPU 52 with 3.39 MHz to transmit the data to the IC card 2, an amplifier 56 which amplifies the modulated data in the modulator portion 54, a coil 59 which exchanges data by radio with the IC card 2,
10 an amplifier 57 which amplifies the data received by the coil 59, a demodulator portion 55 to demodulate the signal amplified in the amplifier 57 with 3.39 MHz, and a matching circuit 58 for impedance matching.

The IC card 2 comprises an induced voltage
15 generator portion 28 and an internal circuit 29, and the internal circuit 29 is composed of the following: a memory 63 which stores data concerning railway tickets, commutation tickets, etc., a CPU 62 which controls the memory 63 concerning read, write, etc., a modulator portion
20 65 which modulates the data read from the memory 63 with a signal of 3.39 MHz, an amplifier 67 which amplifies the signal from the modulator portion 65, a coil 69 which exchanges data by radio with the coil 59 of the data receiving and transmitting portion 51, an amplifier 66
25 which amplifies the data received by the coil 69, a

- 37 -

demodulator portion 64 which demodulates the signal amplified in the amplifier 66 with 3.39 MHz, and a matching circuit 68 for impedance matching.

In the constitution as mentioned in the above,
5 power is transmitted by radio from the reader and/or writer 1 provided at a gate in a railway station or on a bus to an IC card which is passed the reader and/or writer with noncontact or in the proximity to it, a stabilized DC voltage of 7 to 15 volt is supplied to the internal circuit
10 on the IC card 2, which makes it possible to let the internal circuit 29 including the CPU 62, etc. operate stably. In the result, it is made possible that an IC card 2 is able to exchange data by radio concerning railway tickets, commutation tickets, etc. with the reader and/or
15 writer provided at a wicket or on a bus when the IC card 2, being held by a user, is passed the reader and/or writer with noncontact or at a distance of about 5 to 20 cm; thereby, it is made possible that an IC card 2 functions as a railway ticket or a commutation ticket.

20 Fig. 13 shows the state of one or two circuit chips 70 mounted with parts such as the coil 26, the coil 69, and other circuits, 28, 27, 29, and 32, being connected to the coil 26 and the coil 69.

In the case of the embodiment shown in Fig. 9, the
25 length of the coil 26 will be lengthened by increasing

- 38 -

number of turns and taps, T1, T2 and T3 will be provided to input to the circuit chip 70.

Fig. 14 shows a schematic view of an embodiment concerning the whole including a part where an IC card functions the role of a railway ticket, commutation ticket, or the like in exchanging data concerning railway tickets, commutation tickets, etc. with a reader and/or writer by radio. The second embodiment shown in Fig. 14 shows the case where both transmission of power and communication are performed using a radio wave being composed of a power transmission wave and data communication modulated wave as shown in Fig. 15 between a R/W coil (coil-shaped or spiral-shaped R/W antenna) 101 provided on the R/W unit 1 and a card coil (coil-shaped or spiral-shaped card antenna) 201 provided on an IC card 2. As shown in the above, in the ASK modulation system, the power transmission wave and the signal wave have different frequency components seen from a frequency region, but seen from a time region only the amplitude of the power transmission wave varies corresponding to the signal speed. In other words, in the time region, the modulated wave of the power transmission wave multiplied by the signal wave is seen as if only the amplitude is varied up and down. When the modulated wave is transmitted by radio, it can be considered to use separate antennas respectively, but in the present

- 39 -

invention, in order to simplify the noncontact card 2
(proximity radio card, IC card), the field intensity is
limited to be within the range decided by the Wireless
Telegraphy Act (500 μ V at a distance of 3m) and a single
5 antenna (R/W coil) is used to transmit the modulated wave.

The R/W (reader and/or writer) unit 1 comprises the
following: a power supply 105 which generates a high
frequency voltage of 13.56 MHz, an encoder circuit 107
which encodes input data 106 to be transmitted to a
10 proximity radio card 2, a modulator 108 which superimposes
a voltage being amplitude modulated (amplitude shift keying
modulation) by a signal encoded in the encoder circuit 107
upon a high frequency voltage of 13.56 MHz generated in the
power supply 105, a transmitting amplifier 109 which
15 amplifies a signal ASK-modulated and superimposed upon the
high frequency voltage of 13.56 MHz in the modulator 108,
an impedance matching circuit (feeding circuit) 102 having
a capacitor 104 and being coupled with a signal amplified
in the transmitting amplifier 109 through an inductance
20 coupling 103, a R/W coil 101 which generates a radio wave
to transmit power and data corresponding to the output of
the matching circuit 102 and receives data transmitted from
the card coil 201 of the proximity radio card 2 by a radio
wave, a filter circuit 110 which removes noise from a
25 signal received by the R/W coil 101 and transferred through

- 40 -

the inductance coupling 103 passing through the matching circuit 102, a receiving amplifier 111 which amplifies a signal obtained from the filter circuit 110, a demodulator 112 which demodulates a signal amplified by the receiving amplifier 111 using a signal of high frequency voltage of 13.56 MHz obtained from the power supply 105, and a decoder circuit 113 which outputs a signal as received data 112 in decoding a signal demodulated in the demodulator 112.

A proximity radio card (noncontact card, IC card) 2 comprises a card coil 201, radio chip 202 and a CPU+ interface chip 210. The radio chip 202 and the CPU+ interface chip 210 can be constituted with one chip by miniaturizing the radio chip 202.

The card coil 201 receives a radio wave generated to perform transmission of power and data from the R/W coil 101 in the R/W unit 1, and generates a radio wave corresponding to the transmitting data which is processed by load-switching modulation.

The radio chip 202 comprises: an impedance matching and rectifier circuit 203 which functions as a rectifier for the power signal of 13.56 MHz received by the card coil 201 and also functions as a matching circuit for the transmitting and receiving signal, a constant voltage power supply circuit 204 which supplies a constant DC voltage 205 of about 2 to 5 V at a power level of about 5 mW obtained

- 41 -

from a rectified induced voltage output from the matching and rectifier circuit 203, a voltage detector circuit 31 which detects the comparison data between the DC voltage VL obtained from the matching and rectifier circuit 203 and a standard (reference) voltage, a variable impedance control circuit 30 being composed of variable resistor elements such as FET which supplies DC power to the IC chips, 202 and 210, as a DC power supply voltage 205 in controlling the DC voltage output from the constant voltage power supply circuit 204 in varying its impedance based on the DC voltage detected in the voltage detector circuit 31, a clock signal extracting circuit 206 which extracts a clock signal from a receiving signal obtained from the card coil 201, an LPF circuit 207 which removes noise component from the receiving signal obtained from the card coil 201, a waveform shaping circuit 208 which shapes the waveform of a receiving signal obtained from the LPF circuit 207, a load switching modulator circuit 209 which modulates a transmitting signal and supplies the modulated signal to the card coil 201 through the matching and rectifier circuit 203.

The CPU+interface chip 210 is composed of a frequency divider circuit 211 which generates a signal for operating the microcomputer 214 in dividing the frequency of a clock signal extracted by the clock signal extracting

- 42 -

circuit 206 of the radio chip 202, a decoder circuit 212 which decodes a signal obtained from the waveform shaping circuit 208 of the radio chip 202, a receiving data control circuit 213 which controls decoded data (receiving data) obtained from the decoder circuit 212 and inputs the data to the microcomputer 214, a transmitting data control circuit 215 which obtains data from the microcomputer 214 in controlling the transmitting data, an encoder circuit 216 which encodes transmitting data obtained from the transmitting data control circuit 215 in controlling them and inputs the data to the load switching modulator circuit 209 of the radio chip 202, and a microcomputer 214 of H8, etc. which comprises a built-in memory for storing information as a card and performs the processing of transmitting and receiving data and the transfer of data with the memory; thereby the CPU+interface chip 210 will be supplied with a stable power supply voltage 205 from the constant voltage power supply circuit 204 on the radio chip 202.

The purpose of using the R/W coil 101 and the card coil 201 for transmitting power by a radio wave is to upgrade the efficiency of power transmission in a short range. When the coil 201 is formed on the proximity radio card, it helps the card to be strong against deformation. Both R/W coil 101 and card coil 201 can be formed with

- 43 -

spiral antennas.

Even in a case where the distance between the IC card 2 and the reader and/or writer 1 is extremely large, in order to be able to supply a desired DC voltage to the internal circuits, 210 and 202 (29), a resonance circuit is formed in the card coil 201 in connecting a tuning capacitor to it. When the card coil 201 is formed to have a multilayered structure of more than 2 layers, which can be formed by winding a spiral-shaped antenna coil consecutively in the same direction, the inductance of the coil and the stray capacity among the windings may constitute a resonance circuit. As a result, a tuning capacitor 25 may not be needed or an extremely small one will do the work.

Since a full wave rectifier circuit is employed as the rectifier circuit 203, ripples are little and a smoothing capacitor becomes small, so that a smoothing capacitor can be incorporated in a chip in miniaturizing it, which makes it possible to miniaturize the radio chip 202.

In particular, the elements in the pressure protection circuit can be miniaturized by providing a variable impedance circuit 30 composed of variable resistor elements after the constant voltage power supply circuit provided following the rectifier circuit 203, in the

- 44 -

result, the radio chip 202 can be formed small and the cost of not only the chip but also that of the IC card can be decreased, moreover the temperature rise in the variable impedance circuit 30 composed of variable resistor elements can be decreased, which will upgrade the reliability of the chip 220.

As explained in the above, in a proximity radio card system, power can be transmitted by radio, and further information communication by radio can be performed between the reader and/or writer 1 and the noncontact card 2 when the noncontact card (proximity radio card , IC card) 2 is made to approach the reader and/or writer 1. In other words, in a proximity radio card system, a power transmission wave or communication wave is radiated by a coil or a spiral antenna 101 in a reader and/or writer, and the radio wave is received by a coil or a spiral antenna 201 on the side of a card; thereupon, a voltage is induced which operates the circuits on the side of the card and signals are detected.

As explained in the above, according to the present invention, there is an effect that a system can be realized in which power can be stably supplied by radio from a reader and/or writer device (power transmitting device) to the internal circuit on the IC card in miniaturizing the elements in the pressure protection circuit and decreasing

- 45 -

the temperature rise in the variable impedance circuit even when the distance between the IC card and the reader and/or writer device may be largely varied, In particular, since it is made possible to miniaturize the elements in the pressure protection circuit and to decrease the temperature rise in the variable impedance circuit, an IC card can be constituted with an antenna for receiving a radio wave and the elements of one chip, which allows to realize a low cost IC card.

According to the present invention, there is an effect that a power transmission system by radio and an IC card can be realized, wherein the IC card is arranged to be able to perform transmission of power by radio for the reader and/or writer using a coil-shaped or spiral-shaped antenna coil, and power can be stably supplied by radio from a reader and/or writer device (power transmitting device) to the internal circuit on the IC card by only making the IC card pass the reader and/or writer device (power transmitting device) with noncontact or in proximity to it in miniaturizing the elements in the pressure protection circuit, decreasing the temperature rise in the variable impedance circuit, and improving the responsibility of the system.

According to the present invention, there is an effect that a power transmission system by radio, an IC

- 46 -

card, and an information communication system using the IC
card can be realized, wherein even though the distance
between the IC card and the reader and/or writer may
largely vary, power can be supplied stably to the IC card
5 in decreasing the temperature rise in the variable
impedance circuit by controlling the induced power received
on the IC card side varying the static capacity in the
circuit According to the present invention, a proper
power can be transmitted from the power transmission
10 portion of the reader and/or writer to the IC card by radio
by only passing the IC card through the reader and/or
writer with noncontact or in proximity to it; thereby, a DC
voltage can be stably supplied to the internal circuit of
the IC card and information communication can be performed
15 with high reliability between the reader and/or writer and
the IC card.

According to the present invention, there is an
effect that an information communication system using an IC
card can be realized in which information communication can
20 be performed with high reliability between the reader
and/or writer device and the IC card in supplying a
stabilized power from the reader and/or writer device to
the IC card with noncontact.

- 47 -

WHAT IS CLAIMED IS:

1. A power transmission system in which power is transmitted from a power transmission device to an IC card by radio, wherein said IC card comprises an antenna having a resonance circuit for receiving said transmitted radio wave, a full wave rectifier circuit for rectifying induced power received by said antenna, a power supply circuit which converts a DC voltage rectified in said full wave rectifier circuit into a DC power supply voltage, a detector circuit which detects a rectified DC voltage in said full wave rectifier circuit, an impedance control circuit which obtains a desired power supply voltage by controlling the power supply voltage converted in said power supply circuit in varying its impedance, and an internal circuit to be supplied with the desired power supply voltage obtained from said impedance control circuit.

2. A power transmission system in which power is transmitted by radio from a power transmission device to an IC card, wherein said IC card comprises: a receiver portion for receiving an induced power generated by said transmitted radio wave, rectifier circuit which converts the induced power received in said receiver portion into a DC voltage in rectifying it, a detector circuit portion for

- 48 -

detecting the induced power obtained from said receiver
portion or a voltage corresponding to the induced voltage,
a variable impedance control circuit which varies its
impedance to control the DC voltage obtained from said
5 rectifier control circuit, and an internal circuit to be
supplied with a controlled DC voltage from said variable
impedance control circuit.

3. A power transmission system composed of a power
transmission device comprising: a power supply circuit
10 which generates high frequency power and an antenna which
generates a radio wave corresponding to the high frequency
power generated in said power supply circuit, and of an IC
card comprising: an antenna having a resonance circuit for
receiving a radio wave transmitted from an antenna of said
15 power transmission device, a full wave rectifier circuit
for rectifying the induced power received by said antenna,
a power supply circuit which converts a DC voltage
rectified in said full wave rectifier into a DC power
supply voltage, a detector circuit for detecting the DC
20 voltage rectified in said full wave rectifier circuit, an
impedance control circuit portion which obtains a desired
power supply voltage controlling the power supply voltage
converted in said power supply circuit in varying its
impedance, and an internal circuit to be supplied with a
25 desired power supply voltage obtained from said impedance

- 49 -

control circuit.

4. A power transmission system being composed of a power transmission device comprising: a power supply circuit which generates high frequency power and an antenna which generates a radio wave corresponding to the high frequency power generated in said power supply circuit, and of an IC card comprising: a receiver portion which produces an induced power in receiving a radio wave transmitted from an antenna of said power transmission device, a rectifier circuit portion which converts the induced power produced in said receiver portion into a DC voltage, a detector circuit portion which detects the induced power or a voltage corresponding to said induced power obtained from said receiver portion, a variable impedance control circuit which controls the DC voltage obtained from said rectifier circuit based on the induced voltage detected in said detector circuit portion or a voltage corresponding to said induced power in varying its impedance, and an internal circuit to be supplied with the controlled DC voltage from said variable impedance control circuit portion.

5. A power transmission system in which power is transmitted by radio from a power transmission device to an IC card, wherein said IC card is allowed to convert said transmitted induced power into a DC voltage, to detect said transmitted induced power or a voltage corresponding to

- 50 -

said induced power, to obtain a desired DC voltage in varying a static capacity based on the detected induced power or a voltage corresponding to the induced power, and to supply it to the internal circuit.

5 6. A power transmission system comprising: a power
transmission device having a power supply circuit which
generates high frequency power and an antenna which
generates a radio wave corresponding to the high frequency
power generated in said power supply circuit, and an IC
10 card, wherein said IC care is allowed to convert said
transmitted induce power into a DC voltage, to detect said
transmitted induced power or a voltage corresponding to
said induced power, to obtain a desired DC voltage in
varying a static capacity based on the detected induced
15 power or a voltage corresponding to said induced power, and
to supply the DC voltage to the internal circuit.

7. A power transmission system in which power is
transmitted by radio from a power transmission device to an
IC card, wherein said IC card is allowed to convert said
20 transmitted induced power into a DC voltage to supply it to
the internal circuit, to detect said transmitted induced
power or a voltage corresponding to said induced power, and
to transmit the information concerning the detected induced
power or a voltage corresponding to the induced power by
25 radio to the power transmission device, and the power

- 51 -

transmitted from said power transmission device is controlled based on the transmitted information.

8. A power transmission system in which power is transmitted by radio from a power transmission device to an IC card comprising: an IC card which comprises a converter circuit which converts said transmitted induced power into a DC voltage, an internal circuit to be supplied with the DC voltage which is converted in said convertor circuit, and a detector circuit which detects said transmitted induced power or a voltage corresponding to said transmitted induced power, a transmission means which transmits the information concerning the induced power detected in the detector circuit on the IC card or a voltage corresponding to said induced power by radio to said power transmission device, and a control means which controls the power output from said power transmission device based on the information transmitted by said means.

9. A power transmission system in which power is transmitted by radio from a power transmitting device to an IC card comprising: an IC card which comprises an convertor circuit which converts said transmitted induced power into a DC voltage and an internal circuit to be supplied with the DC voltage converted in said convertor circuit, a detector means which detects the information corresponding to the relative position of the IC card to that of the

- 52 -

power transmission device, and a control means which controls the power output from said power transmission device based on the information detected by said detection means.

5 10. A power transmission system in which power is transmitted from a power transmission device to an IC card by radio comprising: an IC card which converts said transmitted induced power into a DC voltage and supplies the DC voltage to the internal circuit, a detection means
10 which detects the information corresponding to the relative position of the IC card to that of the power transmission device, and a means to obtains a desired DC voltage in controlling the impedance of a circuit on said IC card based on said detected information.

15 11. A power transmission system in which power is transmitted from a power transmission device to an IC card comprising: an IC card which comprises a converter circuit to convert said transmitted induced power into a DC voltage and an internal circuit to be supplied with the DC voltage
20 converted in said converter circuit, a detection means which detects the information corresponding to the relative position of the IC card to that of the power transmission device, and a control means which controls power output from said power transmission device based on the detected
25 information by said detection means.

- 53 -

12. An IC card comprising: an antenna having a resonance circuit for receiving a transmitted radio wave, a full wave rectifier circuit for rectifying an induced power received by said antenna, a power supply circuit for
5 converting a rectified DC voltage in said full wave rectifier circuit into a DC power supply voltage, a detector circuit which detects the rectified DC voltage in said full wave rectifier circuit, an impedance control circuit which obtains a desired power supply voltage in
10 controlling the DC voltage detected in said detector circuit to be a desired DC voltage varying its impedance, and an internal circuit to be supplied with the desired power supply voltage obtained from said impedance control circuit portion.

15 13. An IC card as designated in claim 12, wherein the impedance in said variable impedance circuit portion is formed by resistors.

14. An IC card as designated in claim 12, wherein said full wave rectifier circuit, said power supply
20 voltage, said detector circuit, said impedance control circuit and said internal circuit are organized on one chip.

15. An IC card comprising: a receiver portion which receives an induced power transmitted by radio, a rectifier
25 circuit portion which rectifies induced power received in

- 54 -

said receiver portion and converts it into a DC voltage, a detector circuit portion which detects induced power obtained from said receiver portion or a voltage corresponding to said induced voltage, a variable impedance control circuit in controlling a DC voltage obtained from said rectifier circuit portion based on the induced power detected in said detector circuit portion or a voltage corresponding to said induced power by varying its impedance, and an internal circuit to be supplied with a controlled DC voltage obtained from said variable impedance control circuit portion.

16. An IC card comprising: a receiver portion which receives an induced power transmitted by radio, a rectifier circuit portion which rectifies the induced power received in said receiver portion and converts it to an DC voltage, a detector circuit portion which detects the induced power obtained in said receiver portion or a voltage corresponding to said induced power, a static capacity control circuit portion which obtains a desired DC voltage from said rectifier circuit in controlling the static capacity based on the induced power detected in said detector circuit or a voltage corresponding to said induced power, and an internal circuit to be supplied with a controlled DC voltage obtained from said static capacity control circuit.

- 55 -

17. An information communication system using an IC card comprising: a reader and/or writer device which comprises an information communication portion and a power transmission portion which transmits power from said power transmission portion to and IC card by radio, and an IC card which comprises an antenna with a resonance circuit for receiving a radio wave transmitted from said reader and/or writer device, a full wave rectifier circuit which rectifies the induced power received by said antenna, a power supply circuit which converts a rectified DC voltage rectified by said full wave rectifier circuit into a DC power supply voltage, a detector circuit which detects the rectified DC voltage in said full wave rectifier circuit, an impedance control circuit portion which obtains a desired power supply voltage in controlling the DC voltage detected by said detector circuit to be a desired DC voltage and the power supply voltage converted by said power supply circuit to be a desired power supply voltage in varying its impedance, and an internal circuit to be supplied with a desired power supply voltage from said impedance control circuit portion, said system being constituted to be able to perform information communication using a radio wave between said internal circuit on the IC card and the information communication portion in said reader and/or writer device.

- 56 -

18. An information communication system comprising:
a reader and/or writer device which comprises an
information communication portion and a power transmission
portion which transmits power by radio to an IC card,
5 wherein said IC card is allowed to convert the induced
power transmitted from said reader and/or writer device
into a DC voltage and supply it to the internal circuit, to
detect the induced power transmitted to said IC card or a
voltage corresponding to said induced power, and to
10 transmit the information concerning the detected induced
power or the voltage corresponding to said induced power by
radio to the power transmission portion of said reader
and/or writer device, said reader and/or writer device is
so constituted that it is able to control the power
15 transmitted from said power transmitting portion based on
the information transmitted from said IC card, and said
system comprises such an arrangement that information
communication can be performed by radio between the
internal circuit of said IC card and the information
20 communication portion of said reader and/or writer device.

19. An information communication system using an IC
card comprising: a reader and/or writer device which
comprises an information communication portion and a power
transmission portion and transmits power by radio from said
25 power transmission portion to the IC card, a detection

- 57 -

means which detects the relative position of an IC card to that of the power transmitting portion of said reader and/or writer device, a control means which controls power transmitted from said power transmission portion of said reader and/or writer device based on the information concerning the relative position detected by said detection means, said IC card which converts the induced power transmitted by radio from the power transmission portion of said reader and/or writer device into a DC voltage and supplies it to the internal circuit, and an arrangement so designed that information communication can be performed by radio between the internal circuit of said IC card and the information communication portion of said reader and/or writer device.

20. An information communication system using an IC card as designated in claim 17, wherein in the case of transmission of power by radio from said reader and/or writer device to an IC card and the information communication by radio between the internal circuit of said IC card and the information communication portion of said reader and/or writer device, a common antenna is used which is provided in said reader and/or writer device and said IC card.

21. An information communication system using an IC card as designated in claim 18, wherein in the case of the

- 58 -

transmission of power by radio from said reader and/or
writer device to an IC card, and the information
communication by radio between the internal circuit of said
IC card and the information communication portion of said
5 reader and/or writer device, a common antenna is used which
is provided in said reader and/or writer device and said IC
card.

22. An information communication system using an IC
card as designated in claim 19, wherein in the case of the
10 transmission of power by radio from said reader and/or
writer device to an IC card, and the information
communication by radio between the internal circuit of said
IC card and the information communication portion of said
reader and/or writer device, a common antenna is used which
15 is provided in said reader and/or writer device and said IC
card.

23. An information communication system using an IC
card as designated in claim 17, wherein said reader and/or
writer device comprises: a power supply portion which
20 generates a signal for power transmission, an encoder
circuit which encodes input data to be transmitted, a
modulator which superimposes an amplitude-modulated signal
obtained from the encoder circuit upon a signal obtained
from said power supply portion, a power feeder circuit
25 which feeds power based on the signal obtained from said

- 59 -

modulator, and an antenna which generates said radio wave corresponding to the current fed by said power feeder circuit.

24. An information communication system using an IC
5 card as designated in claim 18, wherein said reader and/or
writer device comprises: a power supply portion which
generates a signal for power transmission, an encoder
circuit which encodes input data to be transmitted, a
modulator which superimposes an amplitude-modulated signal
10 obtained from the encoder circuit upon a signal obtained
from said power supply portion, a power feeder circuit
which feeds power based on the signal obtained from said
modulator, and an antenna which generates said radio wave
corresponding to the current fed by said feeder circuit.

15 25. An information communication system using an IC
card as designated in claim 19, wherein said reader and/or
writer device comprises: a power supply portion which
generates a signal for power transmission, an encoder
circuit which encodes input data to be transmitted, a
20 modulator which superimposes an amplitude-modulated signal
obtained from the encoder circuit upon a signal obtained
from said power supply portion, a power feeder circuit
which feeds power based on the signal obtained from said
modulator, and an antenna which generates said radio wave
25 corresponding to the current fed by said feeder circuit.

- 60 -

26. An information communication system using an IC card as designated in claim 17, wherein said internal circuit of said IC card comprises: a decoder circuit which performs waveform shaping of a modulated wave for communication and decodes it, a microcomputer which inputs receiving data decoded in said decoder circuit and outputs data to be transmitted, an encoder circuit which encodes transmitting data output from said microcomputer, and a modulator which modulates a signal based on the signal encoded in said encoder circuit and inputs the modulated signal to said antenna.

27. An information communication system using an IC card as designated in claim 18, wherein said internal circuit of said IC card comprises: a decoder circuit which performs waveform shaping of a modulated signal for communication detected by said antenna and decodes the modulated signal, a microcomputer which inputs receiving data decoded in said decoder circuit and outputs transmitting data, an encoder circuit which encodes the transmitting data output from the microcomputer, and a modulator which modulates a signal based on the signal encoded in said encoder circuit and inputs the modulated signal to said antenna.

28. An information communication system using an IC card as designated in claim 19, wherein said internal

- 61 -

circuit of said IC card comprises: a decoder circuit which performs waveform shaping of the modulated wave for communication detected by said antenna and decodes the modulated wave, a microcomputer which inputs receiving data decoded in said decoder circuit and outputs transmitting data, an encoder circuit which encodes the transmitting data output from said microcomputer, and a modulator which modulates a signal based on the encoded signal in said encoder circuit and inputs the modulated signal to said antenna.

29. An information communication system using an IC card comprising: a reader and/or writer device which comprises an information communication portion and a power transmission portion and transmits power by radio from said power transmission portion to an IC card, wherein said IC card is allowed to convert induced power transmitted from said reader and/or writer device into a DC voltage and to detect said transmitted induced power or a voltage corresponding to said induced power, to obtain a desired DC voltage in controlling static capacity based on said detected induced power or a voltage corresponding to said induced power in varying its static capacitance and supply the DC voltage to the internal circuit, and said system comprises such an arrangement as to be able to perform information communication using a radio wave between the

- 62 -

internal circuit on said IC card and the information communication portion of said reader and/or writer device.

30. An information communication system using an IC card as designated in claim 29, wherein in the case of power transmission by radio from said reader and/or writer device to the IC card and in the case of information communication using a radio wave between the internal circuit on said IC card and the information communication portion of said reader and/or writer device, a common antenna is used provided in said reader and/or writer device and on said IC card.

31. An information communication system using an IC card as designated in claim 29, wherein said reader and/or writer device comprises a power supply portion which generates a signal for transmitting power, an encoder circuit which encodes the input data to be transmitted, a modulator which superimposes an amplitude-modulated signal obtained from encoder circuit upon a signal obtained from said power supply portion, a feeder circuit which feeds power based on the signal obtained from said modulator, and an antenna which generates said radio wave corresponding to the fed current by said feeder circuit.

32. An information communication system using an IC card as designated in claim 29, wherein said IC card comprises an decoder circuit which performs waveform

- 63 -

shaping of a modulated communication wave and decodes it, a
microcomputer which input receiving data decoded in said
decoder circuit and outputs transmitting data, an encoder
circuit which encodes the transmitting data output from
5 said microcomputer, and a modulator which inputs a signal
to said antenna in modulating it based on the encoded
signal encoded in said encoder circuit.

33. A power transmission system in which power is
transmitted by using a radio wave from the power
10 transmission portion to an IC card, wherein said IC card is
allowed to convert the transmitted induced power into a DC
voltage, to detect said transmitted induced power or a
voltage corresponding to said induced power, and to obtain
a desired DC voltage in controlling inductance based on the
15 detected induced power or the voltage corresponding to said
induced power and to supply the DC voltage to the internal
circuit.

FIG. 1

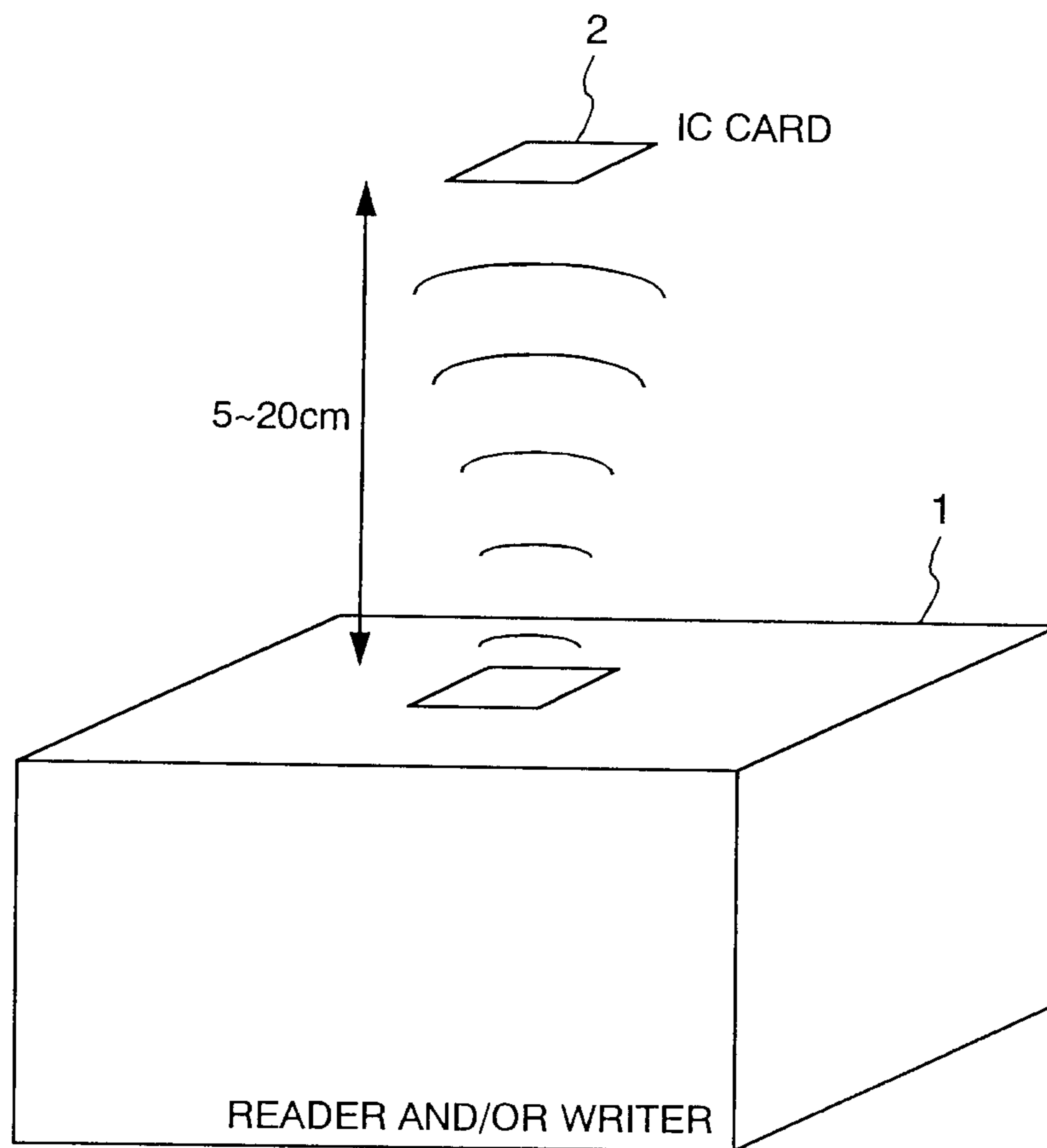

FIG. 2

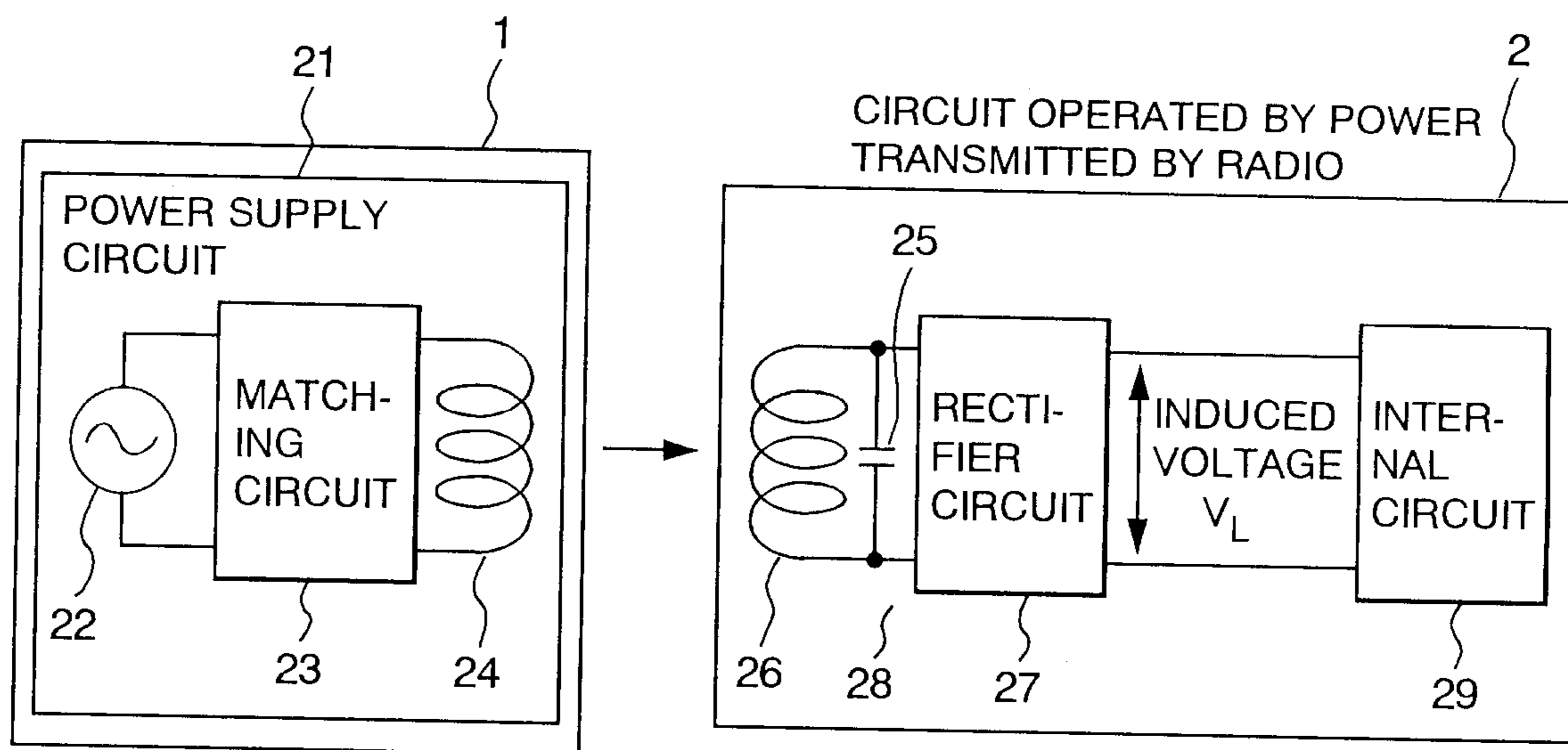

FIG. 3

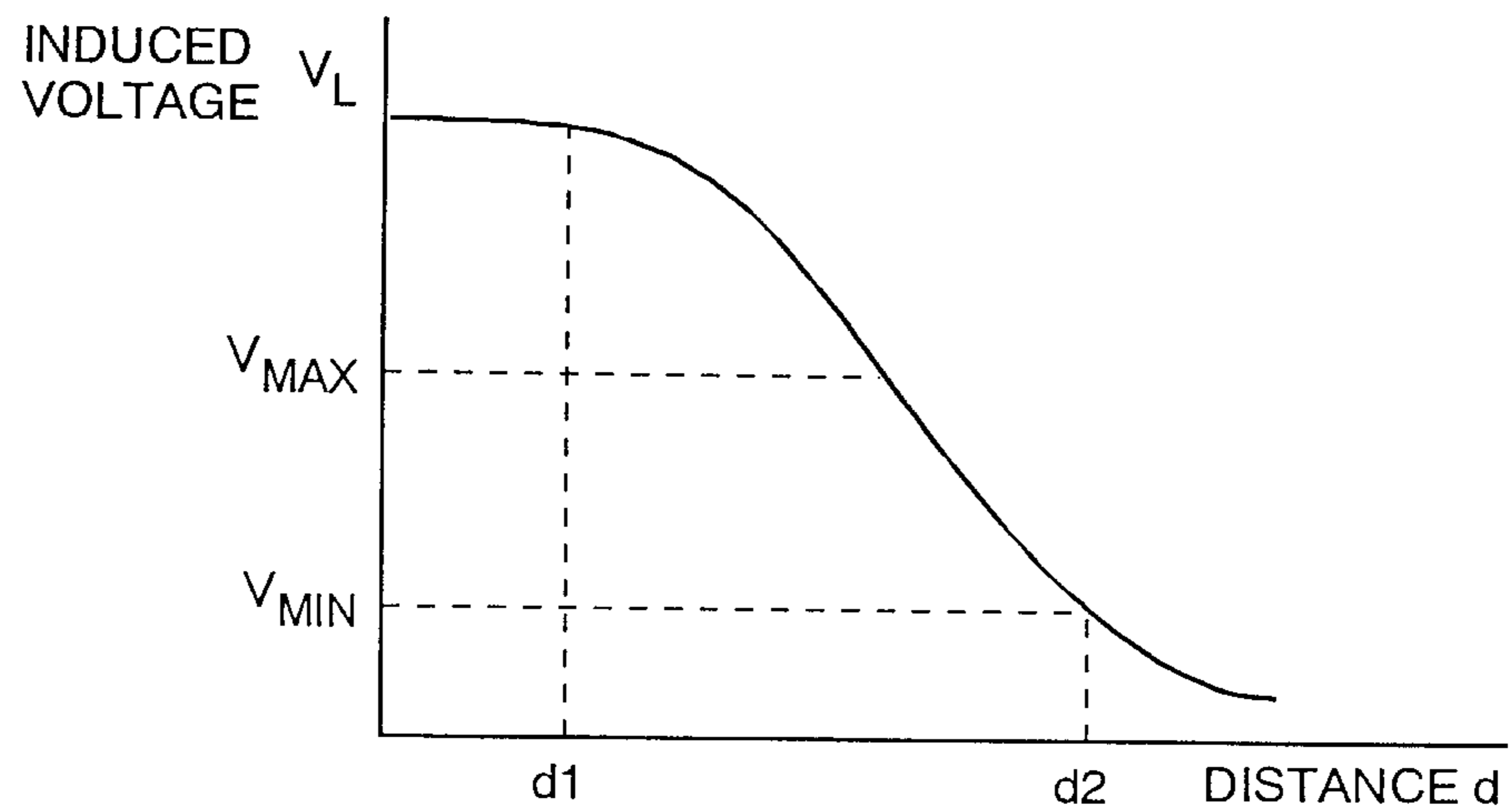

FIG. 4

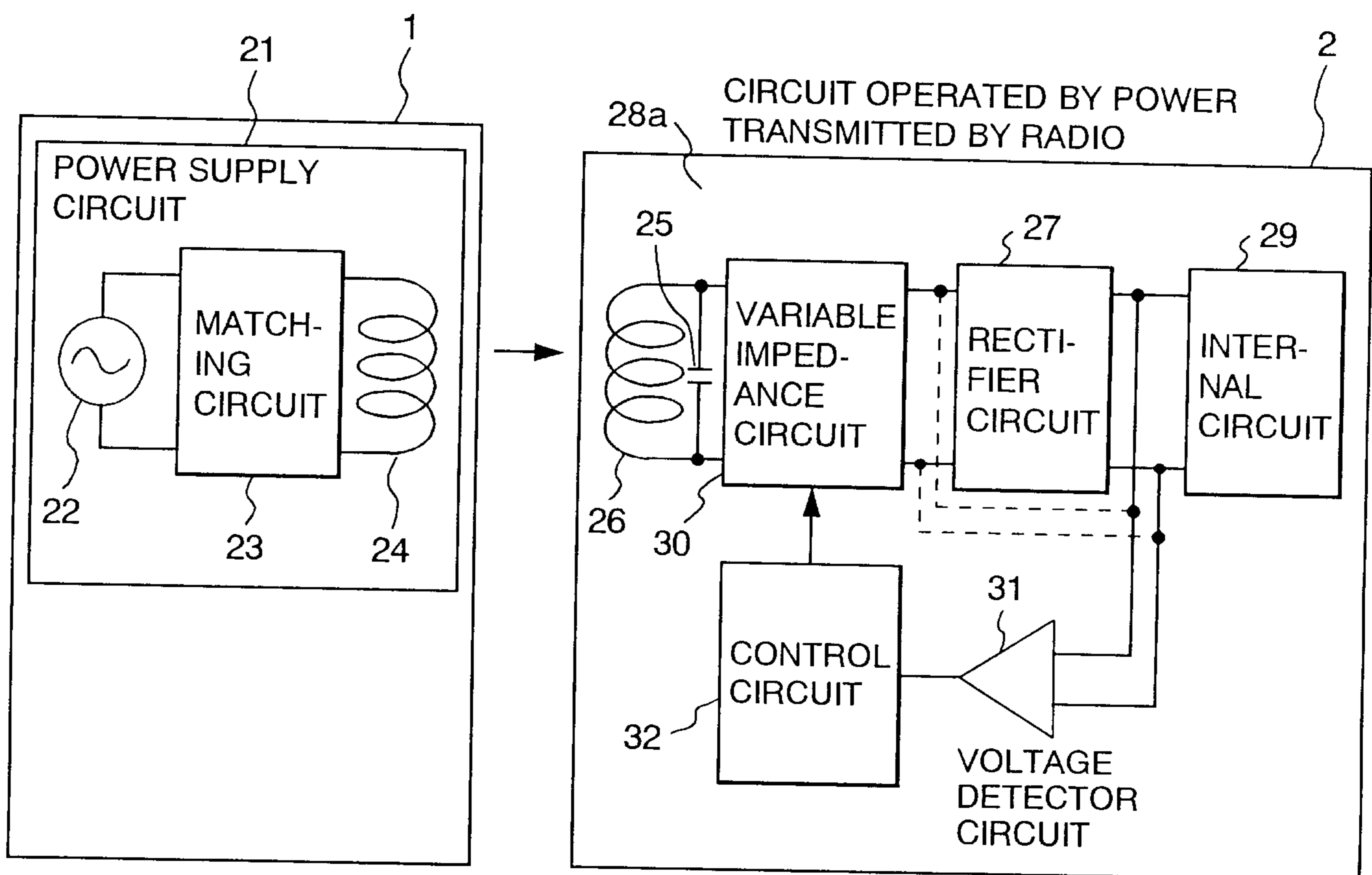

FIG. 5

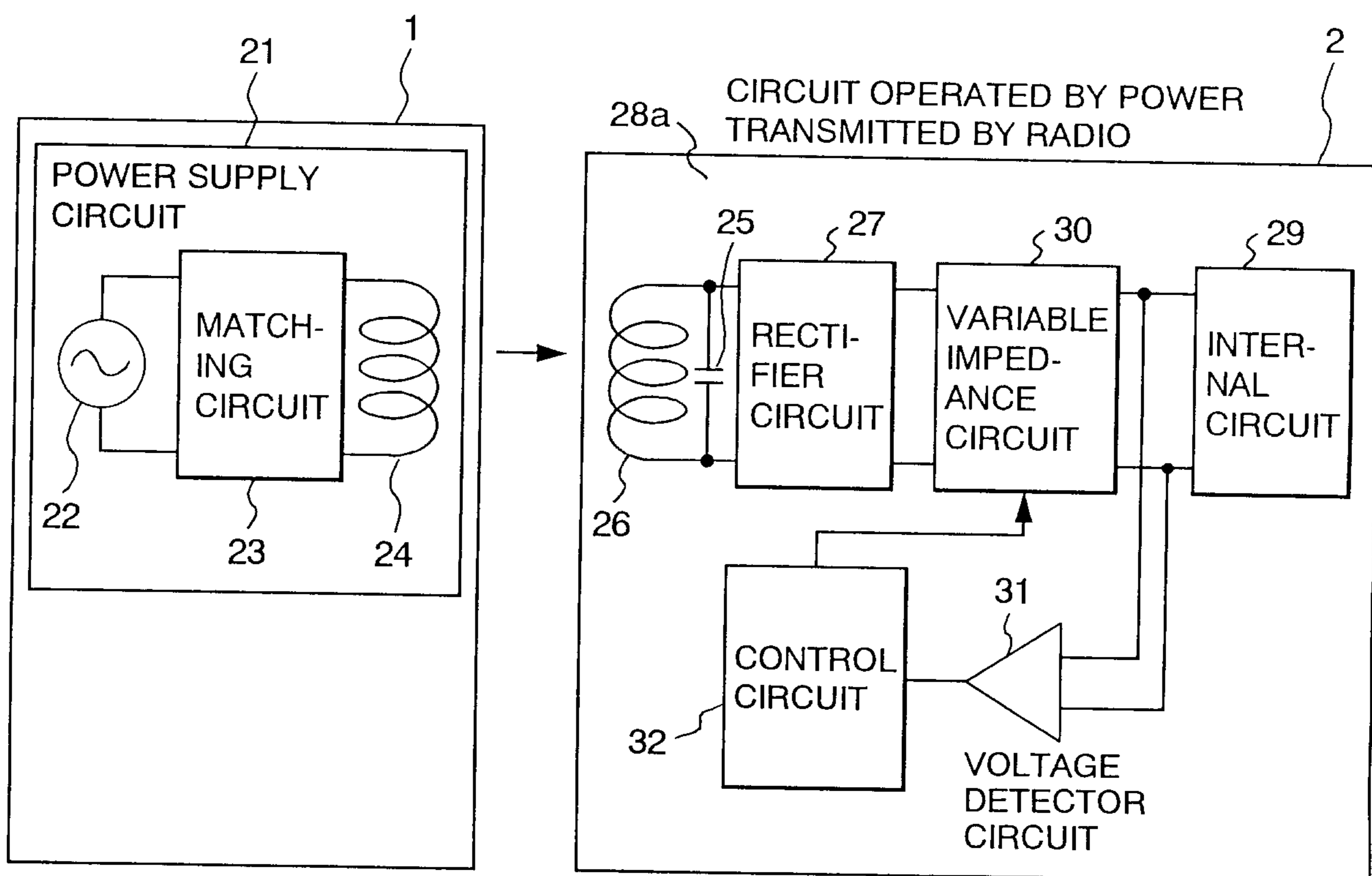

FIG. 6

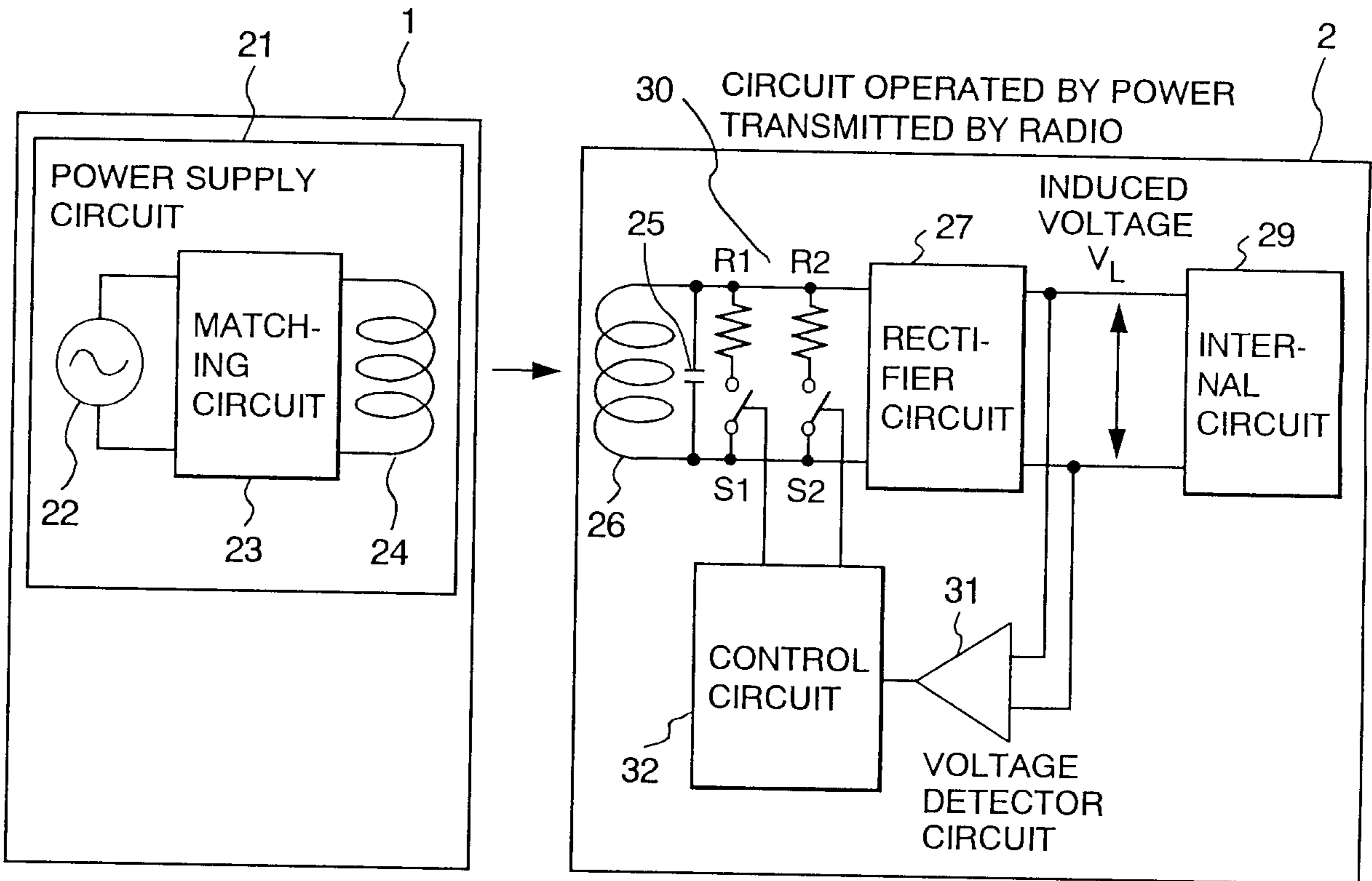

FIG. 7

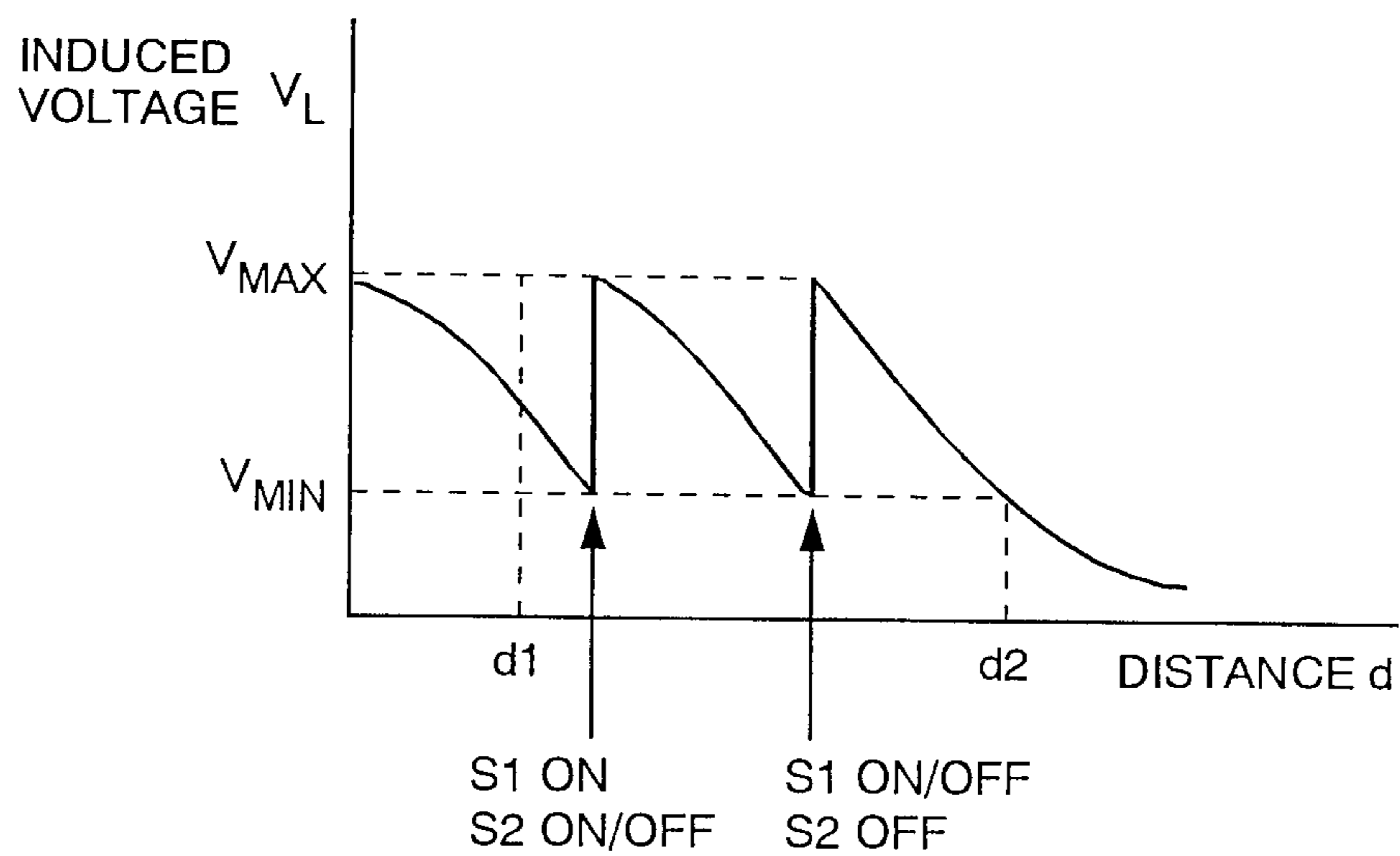

FIG. 8a

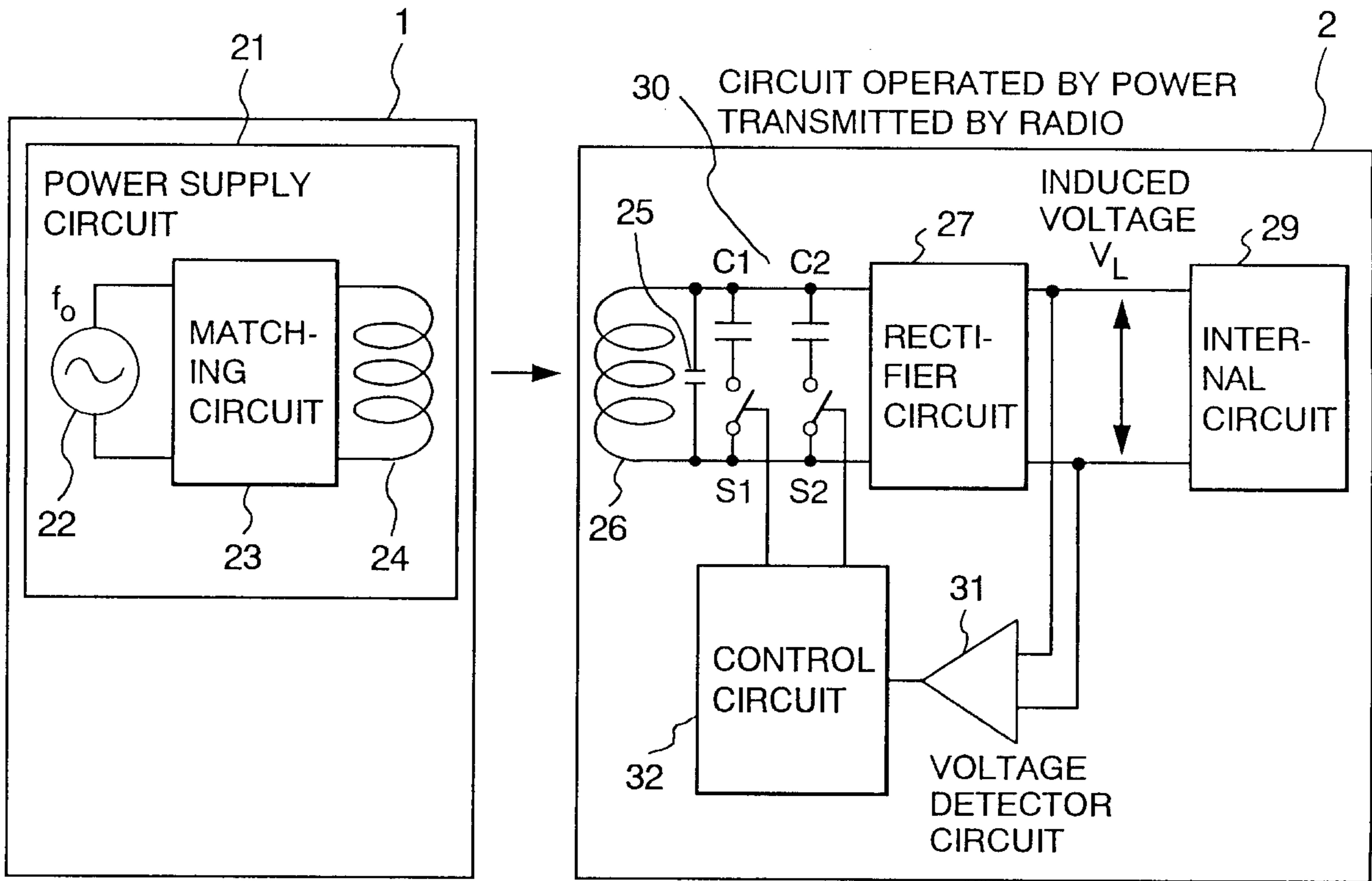

FIG. 8b

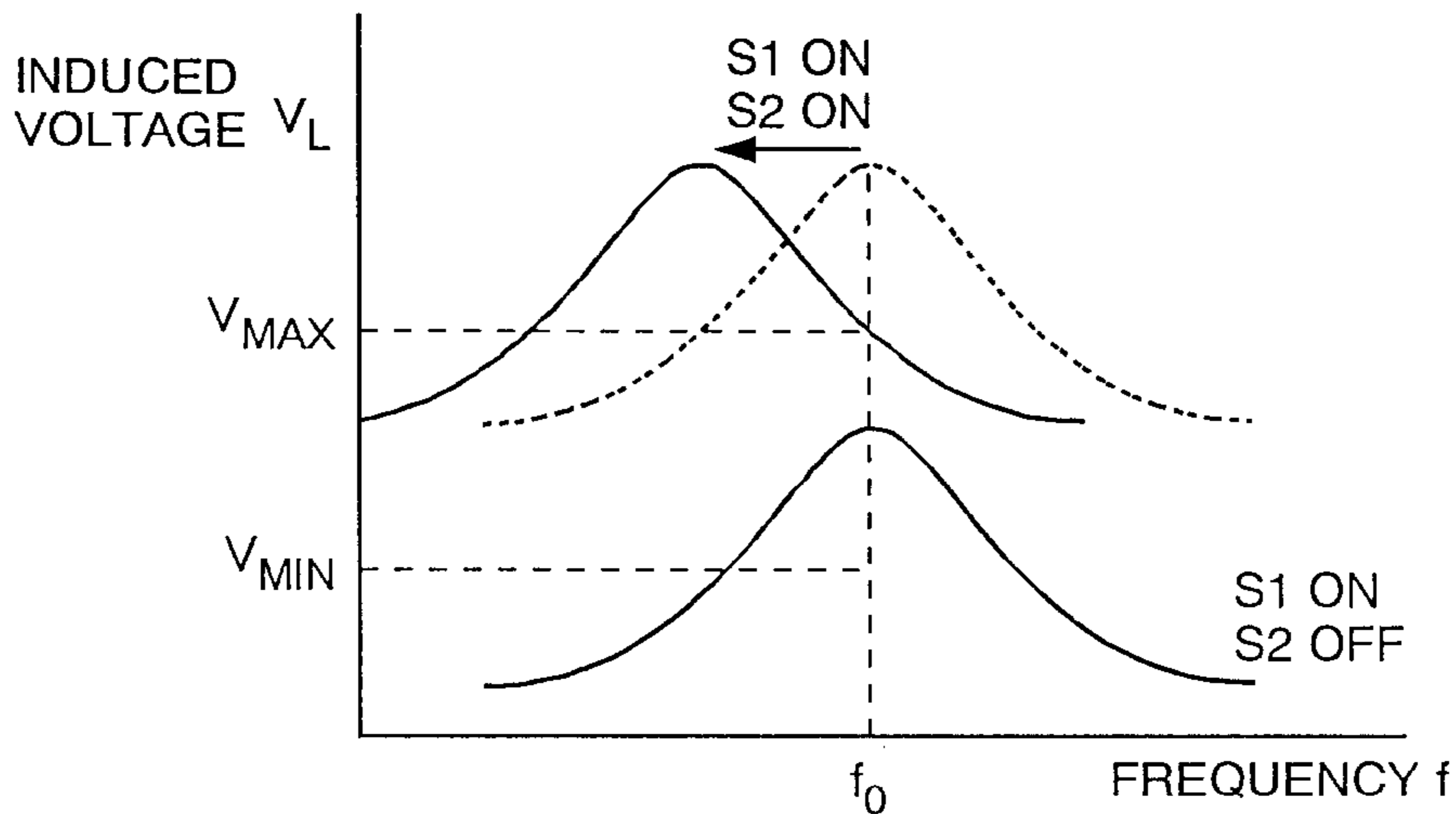

FIG. 9a

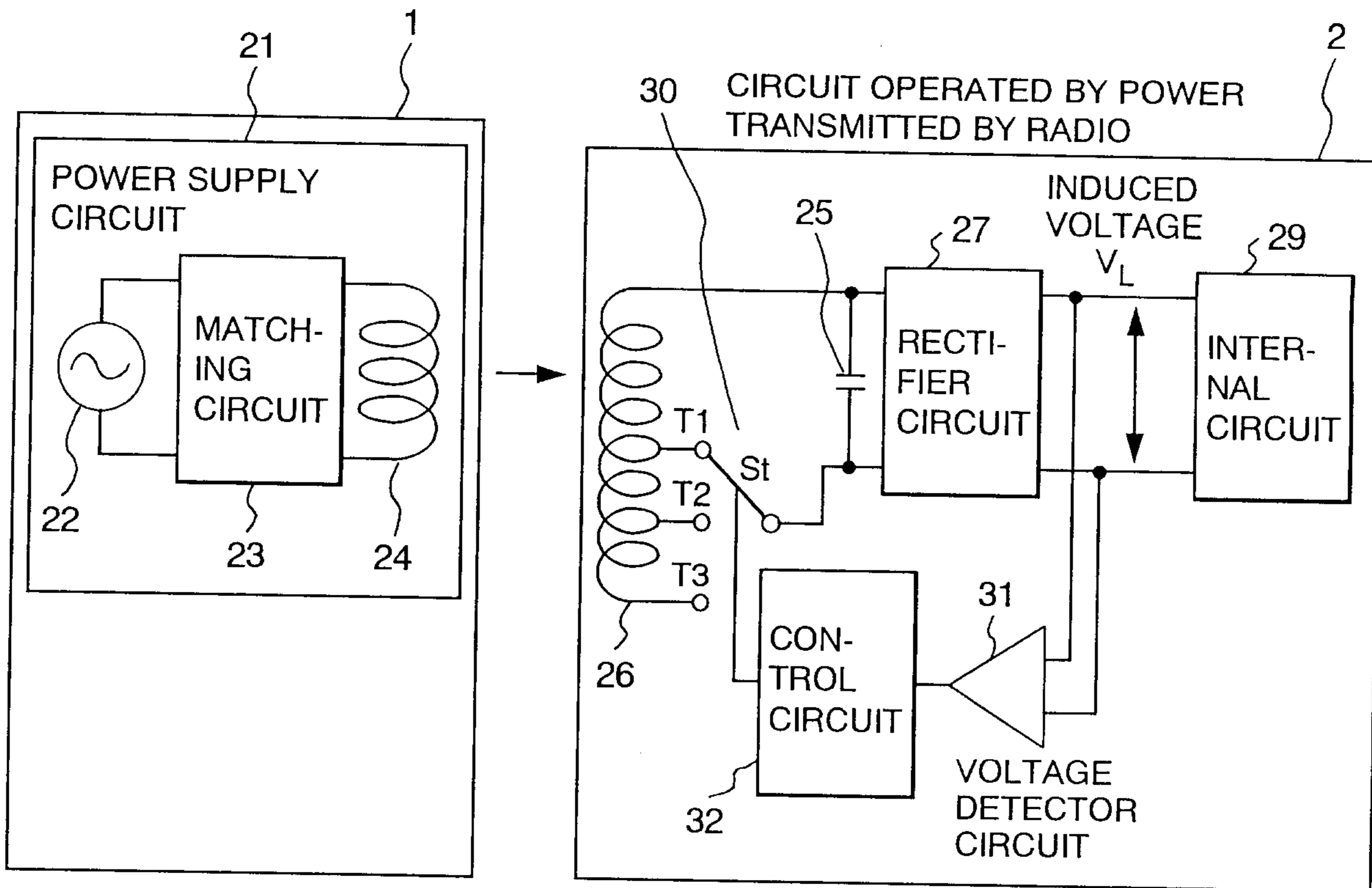

FIG. 9b

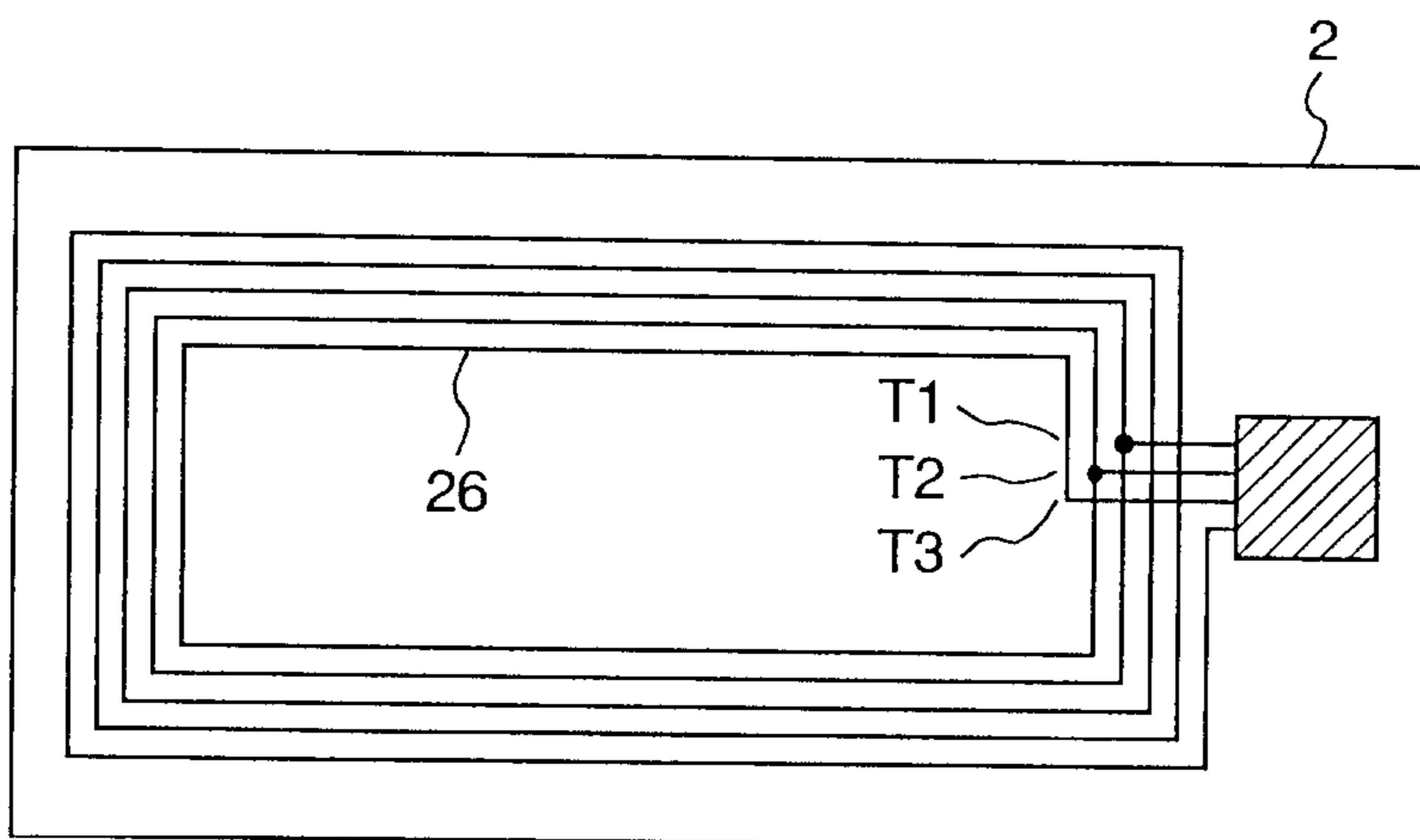

FIG. 10

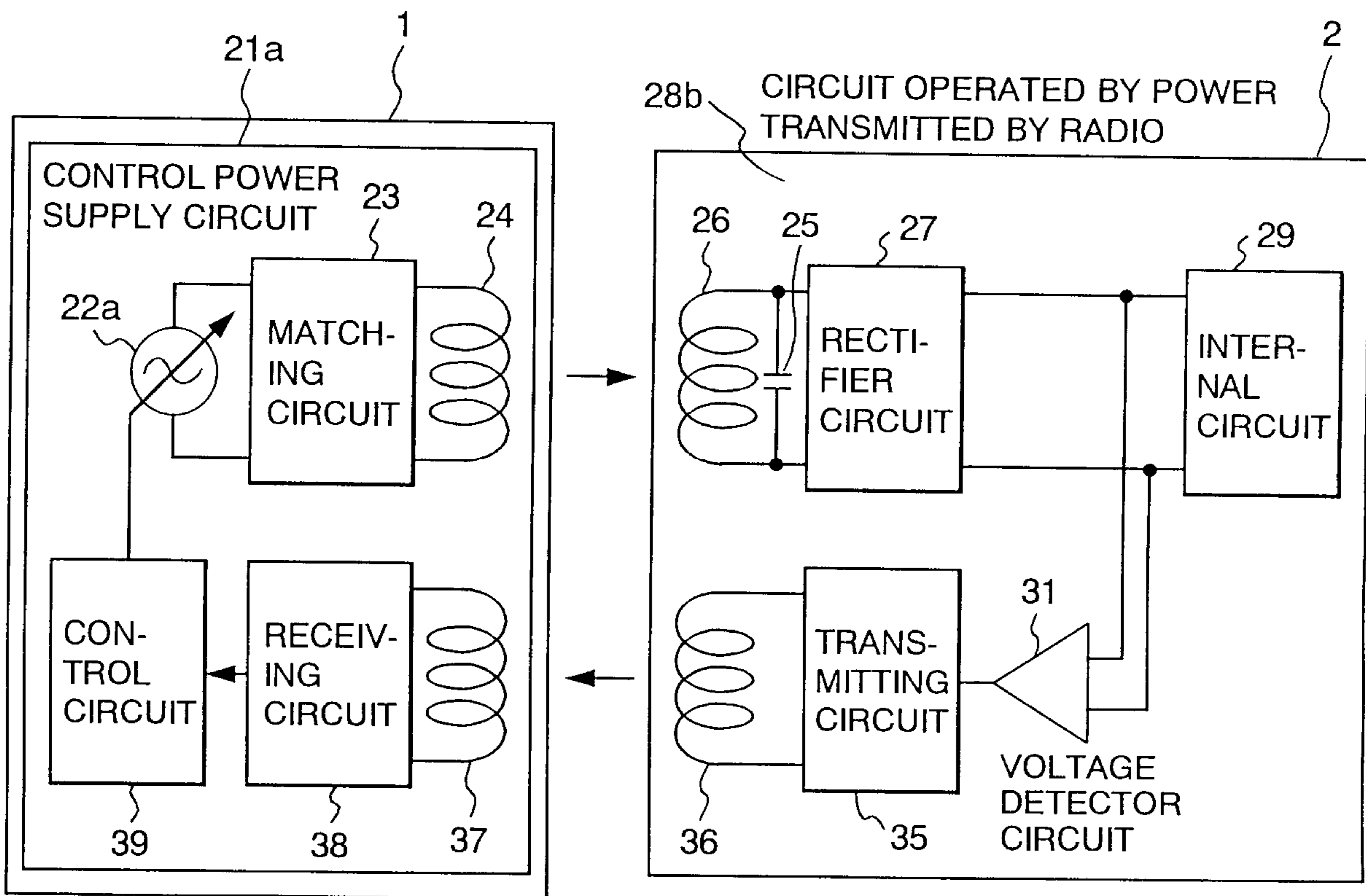

FIG. 11

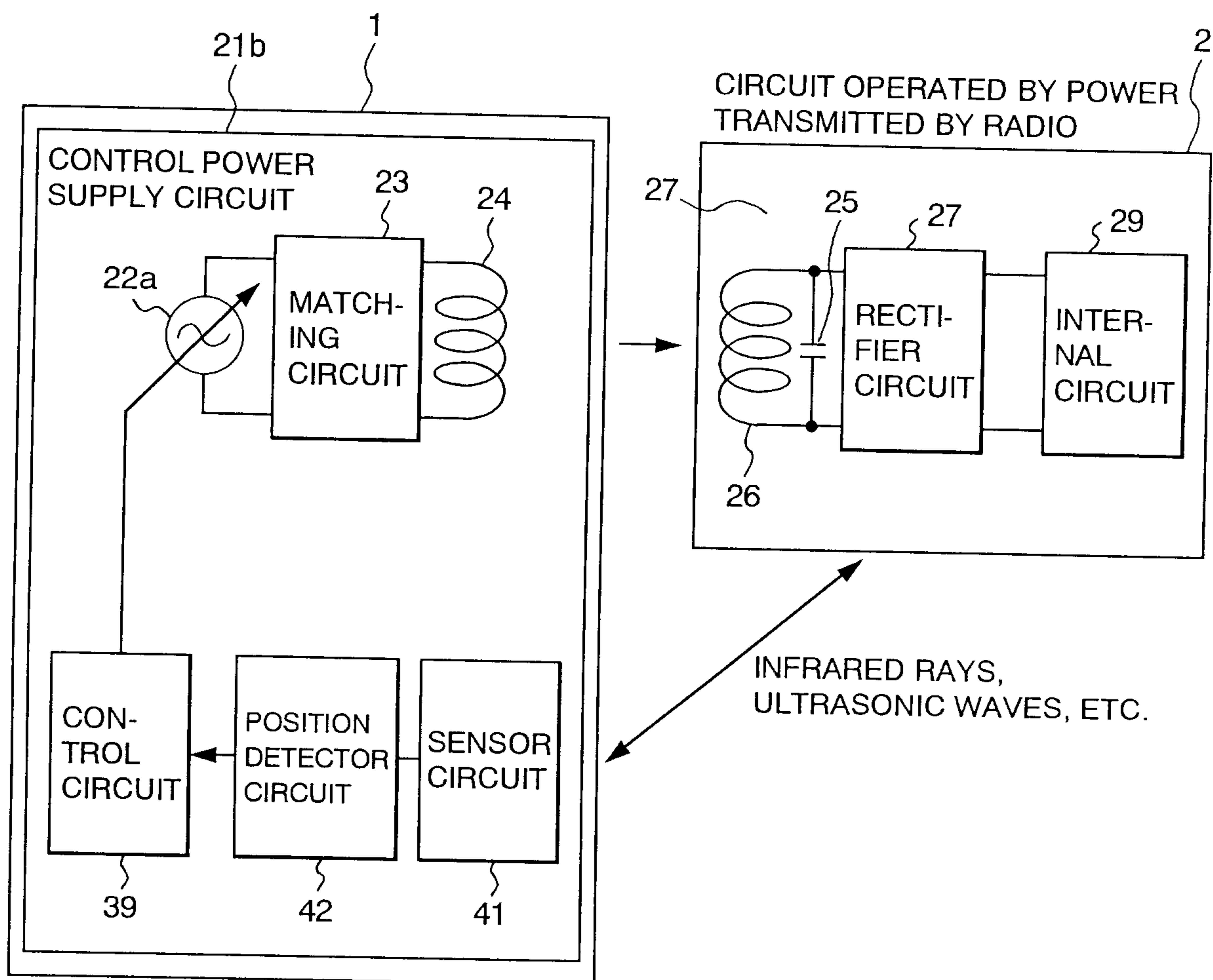

FIG. 12

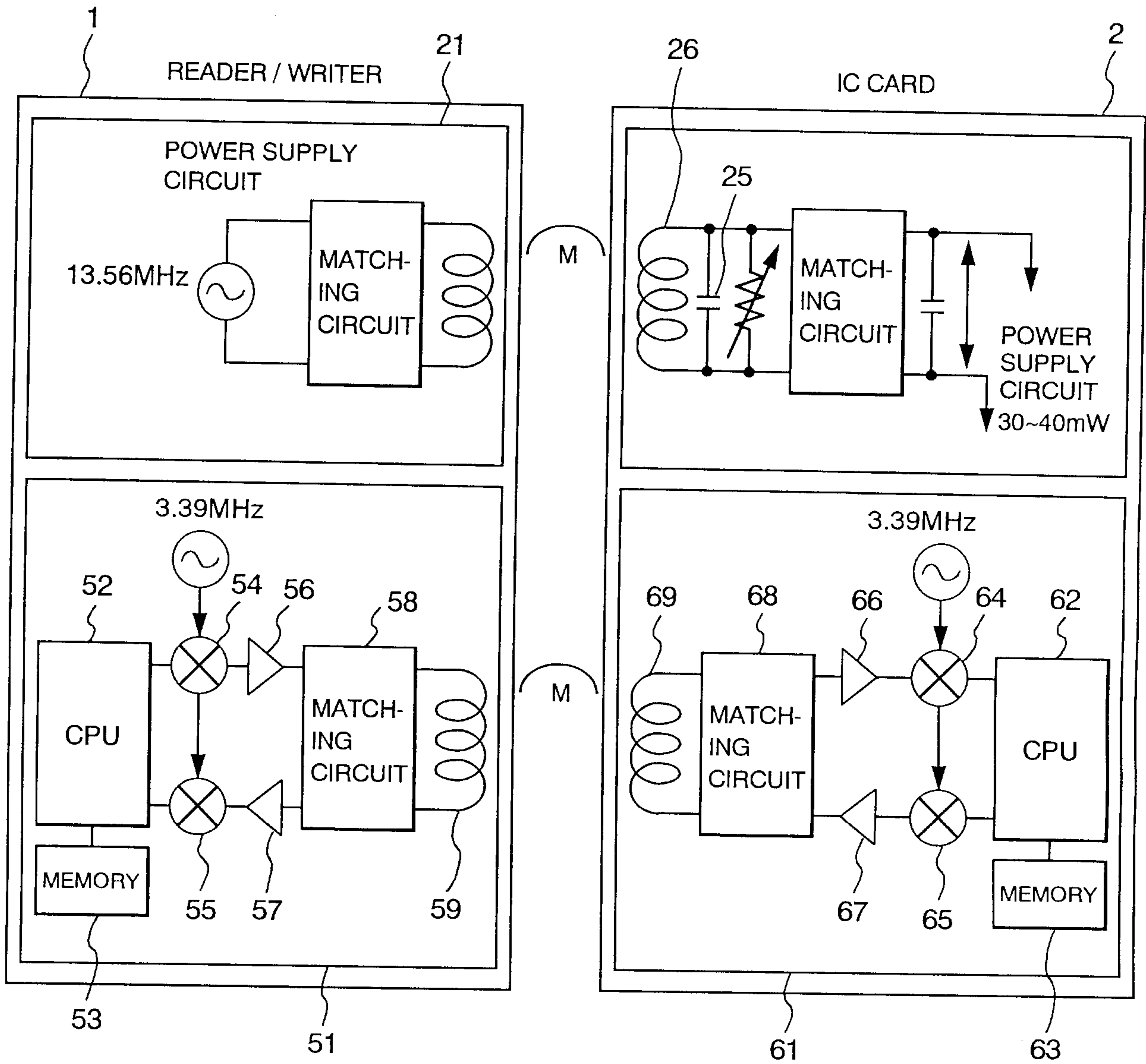

FIG. 13

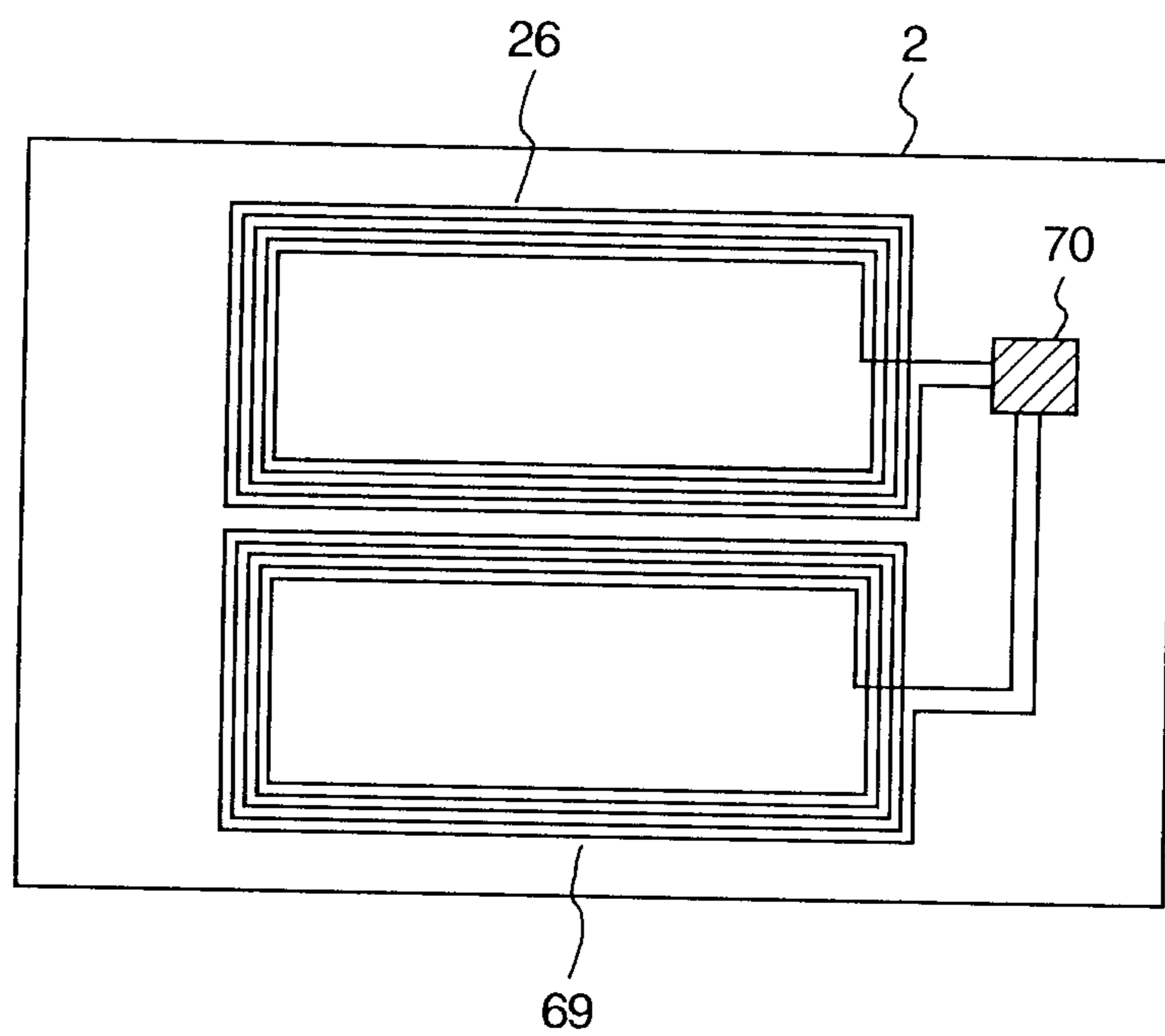

FIG. 14

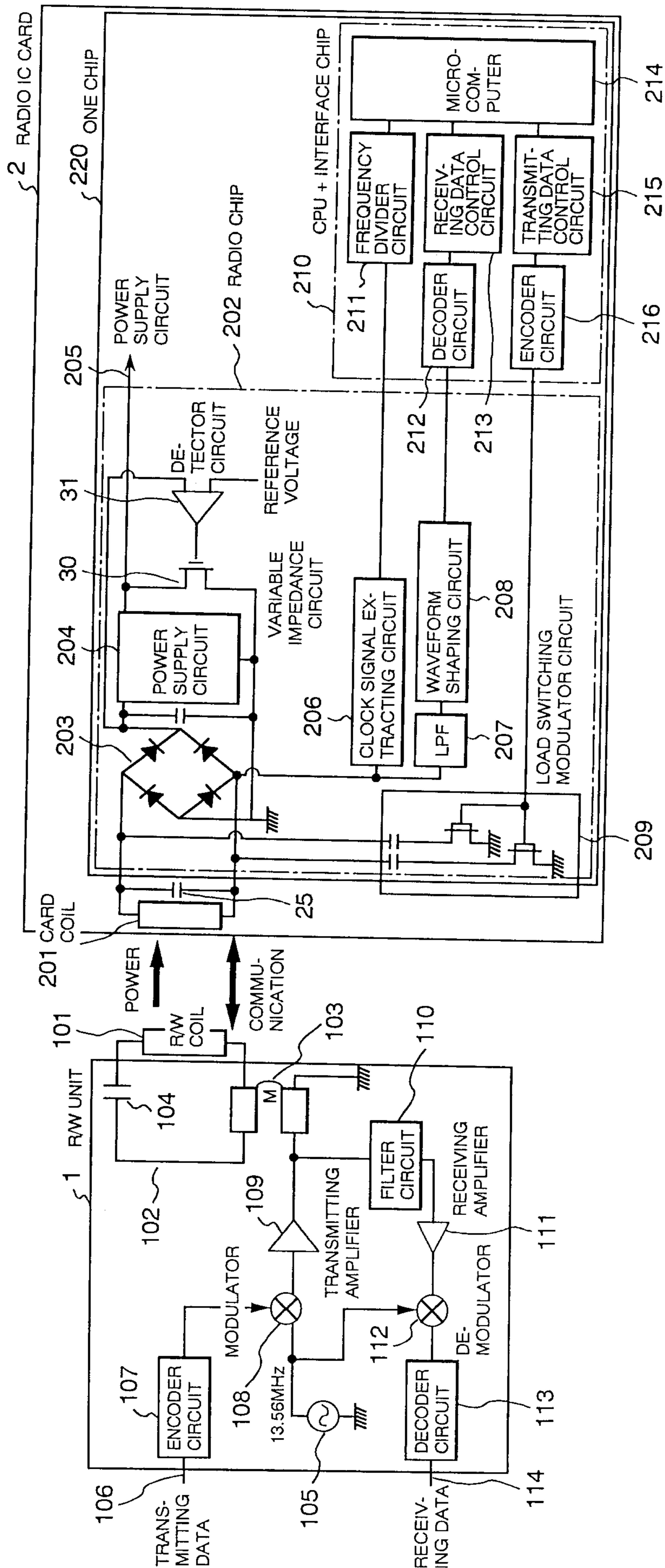

FIG. 15

