

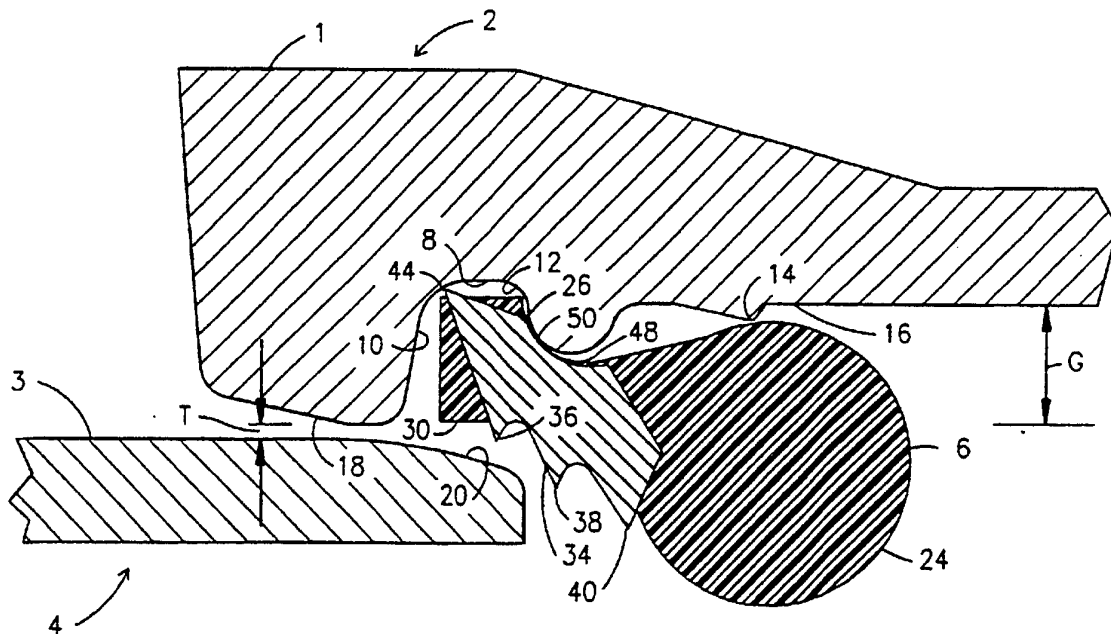

INTERNATIONAL APPLICATION PUBLISHED UNDER THE PATENT COOPERATION TREATY (PCT)

<p>(51) International Patent Classification<sup>5</sup> : <b>F16L 17/00</b></p>	<p><b>A1</b></p>	<p>(11) International Publication Number: <b>WO 95/08072</b> (43) International Publication Date: 23 March 1995 (23.03.95)</p>
<p>(21) International Application Number: PCT/US94/09028 (22) International Filing Date: 5 August 1994 (05.08.94) (30) Priority Data: 08/121,631 16 September 1993 (16.09.93) US (71) Applicant: UNITED STATES PIPE AND FOUNDRY COMPANY [US/US]; 3300 First Avenue North, Birmingham, AL 35202 (US). (72) Inventors: JONES, Lawrence, S.; 3225 Ashwood Road, Hueytown, AL 35023 (US). WEBER, Joe; 2021 9th Place N.W., Birmingham, AL 35212 (US). (74) Agent: CHRYSTAL, John, J.; Ladas &amp; Parry, 224 S. Michigan Avenue, Chicago, IL 60604 (US).</p>		<p>(81) Designated States: BG, PL, RO, European patent (AT, BE, CH, DE, DK, ES, FR, GB, GR, IE, IT, LU, MC, NL, PT, SE).  <b>Published</b> <i>With international search report.</i></p>

(54) Title: IMPROVED RESTRAINING ELEMENT FOR PRESSURE PIPE JOINTS



(57) Abstract

A restraining element for preventing separation of telescoped pipes comprising a compressible body (6) of elastomeric material, the compressible body (6) having metal segments (34) spaced equidistantly around an exposed face of the body, each of the metal segments (34) having a first exposed face with a row of teeth (36, 38, 40), at least four teeth of the row of teeth lying in an arc, and at least some of the metal segments (34) having a single tooth (44) extending radially outwardly beyond the face of the metal segment opposite the first exposed face.

**FOR THE PURPOSES OF INFORMATION ONLY**

Codes used to identify States party to the PCT on the front pages of pamphlets publishing international applications under the PCT.

AT	Austria	GB	United Kingdom	MR	Mauritania
AU	Australia	GE	Georgia	MW	Malawi
BB	Barbados	GN	Guinea	NE	Niger
BE	Belgium	GR	Greece	NL	Netherlands
BF	Burkina Faso	HU	Hungary	NO	Norway
BG	Bulgaria	IE	Ireland	NZ	New Zealand
BJ	Benin	IT	Italy	PL	Poland
BR	Brazil	JP	Japan	PT	Portugal
BY	Belarus	KE	Kenya	RO	Romania
CA	Canada	KG	Kyrgyzstan	RU	Russian Federation
CF	Central African Republic	KP	Democratic People's Republic of Korea	SD	Sudan
CG	Congo	KR	Republic of Korea	SE	Sweden
CH	Switzerland	KZ	Kazakhstan	SI	Slovenia
CI	Côte d'Ivoire	LI	Liechtenstein	SK	Slovakia
CM	Cameroon	LK	Sri Lanka	SN	Senegal
CN	China	LU	Luxembourg	TD	Chad
CS	Czechoslovakia	LV	Latvia	TG	Togo
CZ	Czech Republic	MC	Monaco	TJ	Tajikistan
DE	Germany	MD	Republic of Moldova	TT	Trinidad and Tobago
DK	Denmark	MG	Madagascar	UA	Ukraine
ES	Spain	ML	Mali	US	United States of America
FI	Finland	MN	Mongolia	UZ	Uzbekistan
FR	France			VN	Viet Nam
GA	Gabon				

## IMPROVED RESTRAINING ELEMENT FOR PRESSURE PIPE JOINTS

The invention is in the field of joints for ductile iron pressure pipe and, more specifically, relates to a gasket for preventing separation of the joint formed by telescoping pipes.

In many applications where pipes are joined in telescoping relationship, the smooth or spigot end of one pipe is inserted into the socket end of the engaging pipe. The socket end has an opening large enough to receive the spigot end of the closed pipe. A gasket is inserted in the socket end of the enclosing pipe and prevents leakage of fluid from the joint by forming a seal between the two pipes.

In applications where the fluid such as water for fire mains or water distribution in municipalities is under high pressure, various means are used to prevent separation of the two pipes.

In some instances the pipes are fitted with flanges which are bolted together to prevent separation. This method is costly and time consuming because of the extra steps of inserting and tightening the bolts.

Another method to prevent separation of the pipes is to use blocks or external restraining devices. This method also is expensive and requires careful placement of the blocks.

A still further method is shown in U.S. Patents Nos. 3,963,298 and 4,229,026 in which a rubber gasket which serves as a fluid seal also has toothed metal segments spaced uniformly around its inner perimeter. The toothed metal segments bite into the outer surface of the spigot of the inserted pipe and prevent withdrawal of the inserted pipe. The metal segments pivot about a bead to allow the spigot end of one pipe to be inserted into the socket end of the other pipe while preventing withdrawal of the inserted pipe under high fluid pressure conditions. However, a drawback of this arrangement has been the

fracture or breaking of the socketed portion of the inserted pipe when the teeth of the metal segments dig too deeply into the outer surface of the inserted pipe. This fracture has been noted when the metal segments rotate too far around the bead.

We have previously developed an improved gasket having metal segments with teeth to engage the spigot of a pipe, each of said metal segments also having a tooth on the side of said segment opposite said teeth to prevent excessive rotation of said metal segments.

In the manufacturing of ductile iron pipe, the outside diameter of the spigot end of the enclosed pipe will vary somewhat in size despite efforts to make a standard uniform pipe. Likewise, the bell of the enclosing pipe will vary somewhat in size also.

It is at the extreme circumstances where a spigot end of minimum diameter is inserted into the bell of a pipe with maximum diameter or where a spigot end of maximum diameter is inserted into the bell end of a pipe with minimum diameter that some difficulty has been encountered with this improved gasket having a metal segment with three teeth. It has been found that with only three teeth two positions of the metal segment will occur when the pipes tend to disengage under high pressure.

The invention therefore aims to provide an improved toothed metal segment for preventing disengagement of pipes while also preventing breakage of the spigot end of one of the pipes despite the use of higher pressures in the pipe.

The present invention therefore provides a gasket for preventing separation of telescoped pipes comprising a compressible body having a heel portion and a sealing portion, said heel portion having circumferentially spaced metal segments embedded in an exposed face of said body, each of said metal segments having a row of at least four teeth extending radially inwardly from a first face of

said metal segment, and at least some of said metal segments having a single tooth extending radially outwardly of the side of said metal segment opposite said first face.

Other features and advantages of the present invention will become apparent to those skilled in the art from the following description of the preferred embodiment of the invention taken in conjunction with the accompanying drawing in which like numerals indicate like elements and in which:

Fig. 1 is a fragmented cross-sectional view of a socket or pipe bell of one pipe using the earlier improved gasket noted above and of a spigot or plain end of another pipe entering the pipe bell, and

Fig. 2 of a fragmented cross-sectional view of a socket or pipe bell of one pipe using the earlier improved gasket and of a spigot or plain end of another pipe fully inserted to the socket end of the first pipe.

Fig. 3 is a top view of the earlier improved gasket showing the placement of metal segments around its periphery.

Fig. 4 is a cross-sectional view of a metal segment of the invention.

Fig. 5 is a cross-sectional view of gasket 6 showing the metal segment 34a of Figure 4.

Fig. 6 is a cross-sectional view of a joint using one of the metal segments of the invention.

Fig. 7 is a cross-sectional view of a joint using one of the metal segments of the invention, under different conditions from those shown in Fig. 6, and

Fig. 8 is a cross-sectional view of a joint using one of the metal segments of the invention under different conditions from those shown in Figs. 6 and 7.

Cast iron pressure pipe with a bell on one end and the other plain or bevelled, have, for many years, been joined by utilizing a rubber or elastomeric gasket

which is compressed between the inside walls of the bell and the outside wall of the plain or bevelled end of the next pipe in a series of telescoped pipes. The most successful of such systems provides an elongated retainer groove in the bell with a gasket sealing wall as well as throat and wall portions which guide and limit travel of the plain end as it passes through the bell opening and the rubber gasket. Such a pipe joint is described in U. S. Patent No. 2,953,398 issued September 20, 1960 and U. S. Patent No. 4,108,481 issued August 22, 1982. Gaskets of this type generally have three essential features, a sealing bulb portion, a heel portion and an inner conical wall.

Since both the pipe bell and plain end may be produced without machining, relatively large variations in as-cast diameters are encountered. The gasket sealing bulb, in turn, is subjected to a wide range of compressions from approximately 2% to 45% of its original thickness. To aid in entry of the plain end into the gasketed bell over the large range of diameters encountered, the inner wall of the gasket is generally made in a conical form which tapers from the mating throat diameter of the bell to the inner sealing bulb diameter of the gasket. To further aid in the assembly, the gasket bulb has a relatively soft Shore A durometer hardness between about 40 and 60.

The retainer heel portion of the gasket is typically produced from a higher hardness compound than the sealing bulb to aid in retention of the gasket during joint assembly and to prevent blowout of the softer bulb portion when the assembled joint is subjected to high internal pressures. The retainer heel portion of a typical gasket has a Shore A durometer hardness between about 75 to 90. The retainer heel portion is generally designed to fit into a retaining groove of the bell section of the enclosing pipe. Known gaskets exhibiting these features are asymmetric in cross-sectional profile.

Gaskets of similar asymmetric cross-sectional profiles have also been produced from single hardness rubber compounds. If the entire gasket is of the harder compound, extremely high assembly forces are required. If the entire gasket is of the softer compound, the gasket is subject to be dislodged during assembly and, in addition, only relatively low internal pressures can be held. Single hardness gaskets are, therefore, normally produced of an intermediate Shore A hardness range from between about 60 and 75. In general, with single hardness gaskets of this type, one or more of the attributes of the dual hardness gasket is diminished.

Figure 1 shows a joint which is to be formed between a pipe bell end 1 of one pipe 2 and a plain or spigot end 3 of a second pipe 4. Second pipe 4 is to be pushed into the bell end 1 of the enclosing pipe 2. The gasket 6 is shown in place in pipe bell 1 of pipe 2.

The inner surface of pipe bell 1 has a retainer groove 8 bounded by a front wall 10 and retainer wall 12, and a compression rib 14 which extends radially inwardly from a sealing wall 16. In addition, the bell has a throat portion 18 which extends radially inwardly and joins the front wall 10. As the joint is assembled the throat 18 guides the plain end 3 until the bevelled end 20 contacts the conical inner face (not shown) of the gasket 6. The wedging action between the bevelled end 20 and the conical face compresses the sealing bulb portion 24 of the gasket between the plain end 3 and the compression rib 14 and the sealing wall 16. The retainer wall 12 of the bell inner surface engages the retainer shoulder 26 of the gasket to prevent the gasket from dislodging during assembly of the joint.

In tight joint conditions, the gasket space G between the sealing wall 16 and plain end 3 is relatively small and the gasket compression and joint assembly forces are relatively high. A sealing bulb 24 of gasket 6 of a

relatively soft durometer elastomer is used to reduce the force required for tight joint assemblies. A harder durometer elastomer is used for the retainer heel portion 30 to prevent the gasket from dislodging during tight joint assemblies.

While the joint of the present invention is described in terms of a sealing gasket of dual durometer, the gasket may also be of single durometer.

In loose joint conditions the throat gap T between the throat 18 and the plain end 3 is relatively large. When the pipe joint is pressurized, the gasket is forced toward the front wall 10 and fills the retainer groove 8 of the pipe bell. The softer sealing bulb 24 of the gasket will attempt to extrude through the throat gap T. The harder retainer heel portion 30 of the gasket, resists the extrusion of the softer bulb portion 24 of the gasket through the throat gap T.

While the invention has been described in the environment of a pipe joint in which the bell end of the enclosing pipe has a compression rib 14, the gasket will also perform its sealing function with a bell configuration such as that shown in U. S. Patent No. 2,953,398 which does not have a compression rib.

Inserted into gasket 6 is a series of metal segments 34 formed in accordance with our earlier improved gasket. The segments are spaced apart equally in a circumferential direction around the periphery of gasket 6. Metal segments 34 are firmly vulcanized into gasket 6. The number of metal segments inserted into a gasket will vary depending upon the anticipated fluid pressure at the joint and the size of the pipes involved. For example, for pipes where the spigot end is 24.80" in outer diameter and the anticipated fluid pressure is 700 p.s.i., 42 metal segments are placed at a uniform distance apart around the periphery of the gasket.

The metal segment 34 has three teeth 36, 38 and 40 extending beyond the heel portion 30 of gasket 6 toward

the interior of the gasket. Teeth 36, 38 and 40 are designed to bite into the outer surface of spigot 3 when pipe 4 is inserted into the bell end 1 of pipe 2. Metal segment 34 is similar in design to the metal segment shown in U. S. Patent No. 3,963,298, except that metal segment 34 has three teeth exposed to cut into the outer surface of spigot 3 and a fourth tooth 44, which extends outwardly through the opposite side of gasket. Tooth 44 extends outwardly at the opposite or outer face of gasket 6.

The back or outer face of gasket 6 has a groove 48 lying between heel portion 30 and sealing portion 24 of gasket 6. Groove 48 receives a bead 50 of bell 1. Gasket 6 can pivot partially around bead 50 when spigot 3 is moving into or out of bell 1.

Referring now to Fig. 2, there is shown a joint completed by the full insertion of spigot 3 of pipe 4 into the bell 1 of pipe 2. As spigot 3 of pipe 4 moves into bell 1 of pipe 2 (to the right as shown in Fig. 2), the spigot 3 rides against tooth 40 of metal segment 34 and compresses sealing bulb 24 of gasket 6 to form a fluid-tight seal between the inner surface of pipe 2 and the outer surface of pipe 4. Spigot 3 also pushes against the elastomeric portion of gasket 6 between the metal segments. As spigot 3 pushes against tooth 40, metal segment 34 pivots counter-clockwise around bead 50. At this time, tooth 44, which protrudes outside of the outside portion of gasket 6, rides along the inner face of front wall 10.

The joint is now sealed and fluid under pressure can be carried by the pipe system.

As the fluid pressure rises, there is a tendency for pipe 4 to move to the left and this can cause the joint to be broken. However, as pipe 4 moves to the left, tooth 40 of gasket 6 digs into the outer surface of spigot 3 as metal segment 34 tends to move to the left and to pivot clockwise around bead 50. If the metal segment 34

rotates too far around bead 50, tooth 40 will bite into the periphery of spigot 3 with enough force to break pipe 4.

To prevent the excessive rotation of metal segment 34, tooth 44, which protrudes through the rear or outer face of gasket 6, bites into the inner face of front wall 10. In preventing excessive rotation of metal segment 34, the breakage of pipe 4 is avoided.

Because back tooth 44 bites into the inner face of front wall 10, a stronger joint capable of resisting higher internal pressures is provided since the separating force is transferred from a radial to an axial force acting along the longitudinal axis of the pipe.

Fig. 3 shows a gasket 6 with metal segments 34 spaced at equal distances from each other along the periphery of the gasket. It should be recognized that all of the metal segments 34 spaced around the periphery of gasket 6 operate in the same manner as that described with respect to the metal segment described in the preceding description.

An embodiment of the present invention will now be described with regard to Figs. 4, 5, 6, 7, and 8.

Fig. 4 shows a metal segment 34a similar to the metal segment 34 illustrated in Fig. 1 except that metal segment 34a has a fourth tooth 42. All of the teeth, 36, 38, 40, and 42, lie in a common arc 56. In this invention the arc is a segment of a circle with a radius of .939 inches. However, this specific dimension should be not considered as a limiting factor in the invention.

Figure 5 is a cross-sectional view of gasket 6 with metal segments 34a shown in Figure 4 embedded in the rubber ring of gasket 6.

An example of the use of new segment 34a is shown in Fig. 6 where the tolerance between the pipes is at the extreme where the spigot of the enclosed pipe 3 has a minimum diameter and the bell of the enclosing pipe 1 has

a maximum diameter. In this illustration, as the pipes tend to disengage, metal segment 34a rotates around bead 50 and teeth 40 and 42 of metal segment 34a engage the spigot end of pipe 3.

As shown in Fig. 7, where the tolerance between the pipes is at the extreme where the spigot of the enclosed pipe 3 has a maximum diameter and the bell of the enclosing pipe 1 has a minimum diameter, teeth 36 and 38 of metal segment 34a will engage the spigot end of pipe 3 to prevent disengagement of the pipes.

As shown in Fig. 8 which is the more general case, the tolerances between the spigot end of pipe 3 and the bell of pipe 1 is more like to be an average of the two extreme cases, the middle teeth 38 and 40 of metal segment 34a will engage the spigot end of pipe 3 when the pipes tend to disengage under high fluid pressure.

Thus, the invention is more universal in scope than other gaskets with metal segments.

In summary, the invention, by using metal segments having a tooth on its rear surface and four teeth in an arc on its opposite face has greater flexibility in preventing rupture of the spigot of an enclosed pipe.

While the present invention has been described with respect to specific embodiments thereof, it should be understood that the invention is not limited thereto as many modifications thereof may be made. It is, therefore, contemplated to cover by the present application any and all such modifications as fall within the true spirit and scope of the appended claims.

CLAIMS

1. A gasket for preventing separation of telescoped pipes comprising a compressible body having a heel portion and a sealing portion, said heel portion having circumferentially spaced metal segments embedded in an exposed face of said body, each of said metal segments having a row of at least four teeth extending radially inwardly from a first face of said metal segment, and at least some of said metal segments having a single tooth extending radially outwardly of the side of said metal segment opposite said first face.

2. The gasket of claim 1 in which said gasket has a heel portion having a preselected Shore hardness and said sealing portion having a Shore hardness less than said preselected Shore hardness of said heel portion.

3. The gasket of claim 1 or 2 in which said heel portion and said sealing portion are of the same Shore hardness.

4. The gasket of claim 1, 2 or 3 in which said row of teeth comprises at least four teeth which lie in an arc.

5. The gasket of any of claims 1 to 4 in which each of said metal segments has a single tooth extending radially outwardly of the side of said metal segment opposite said first face.

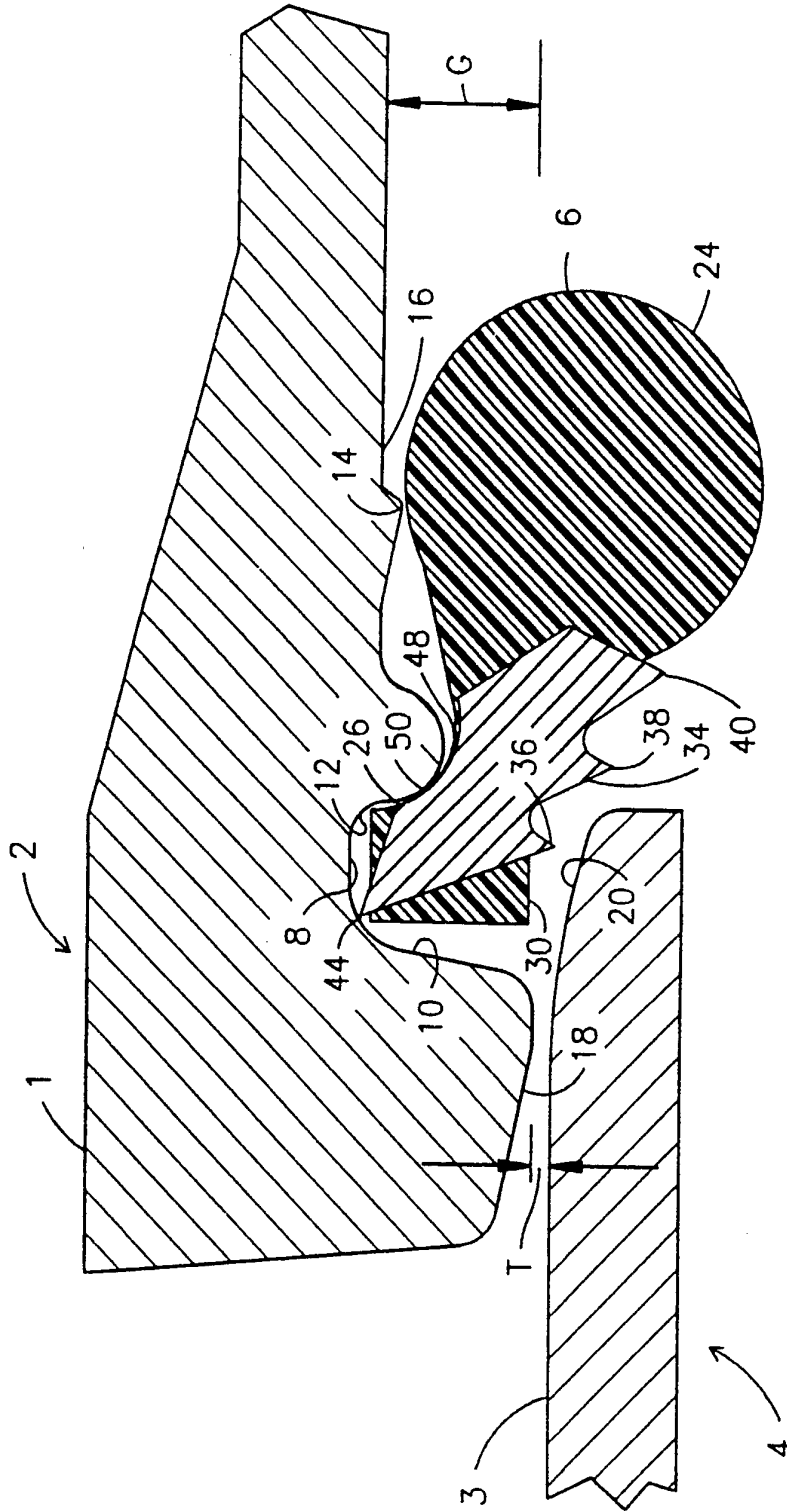

Fig. 1

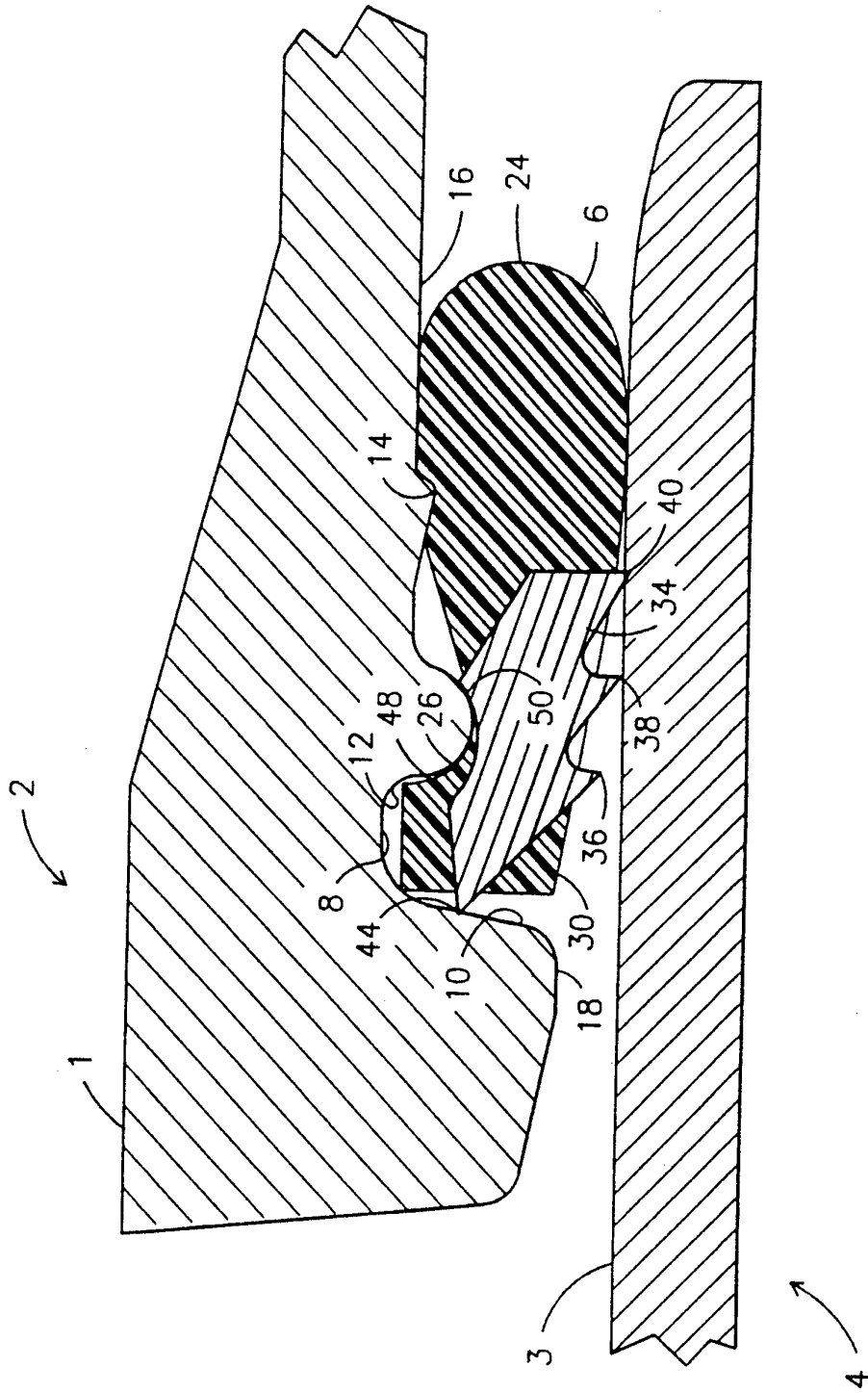

Fig. 2

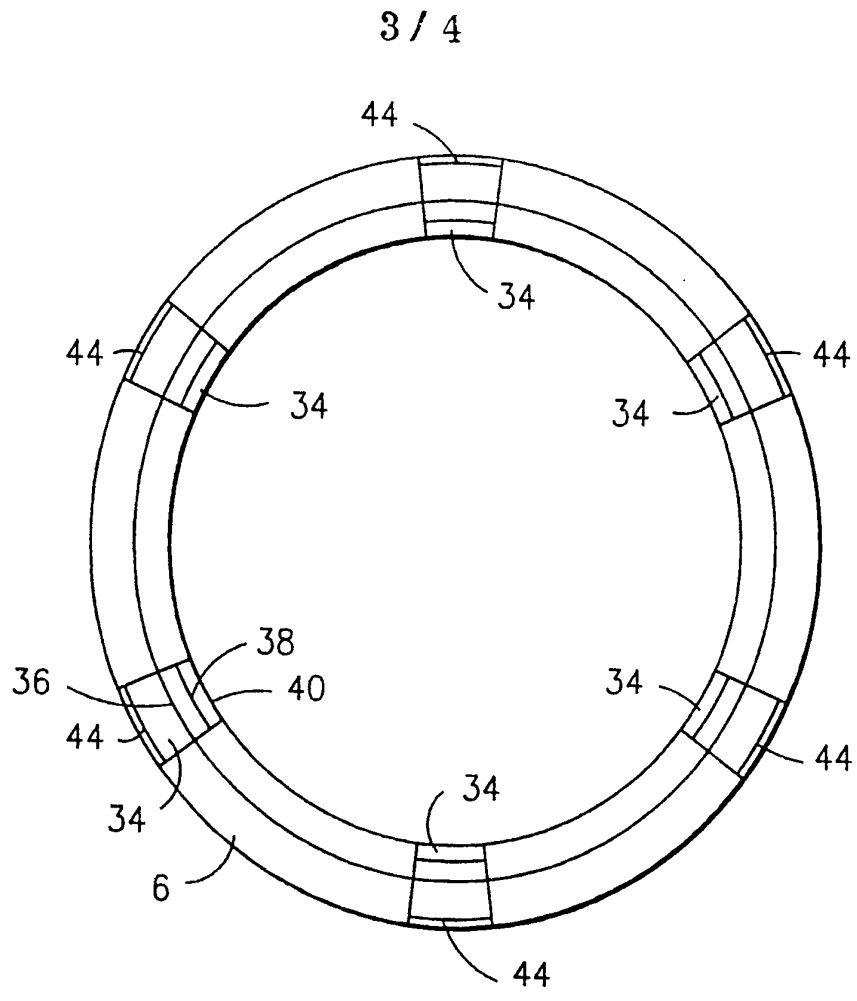

Fig. 3

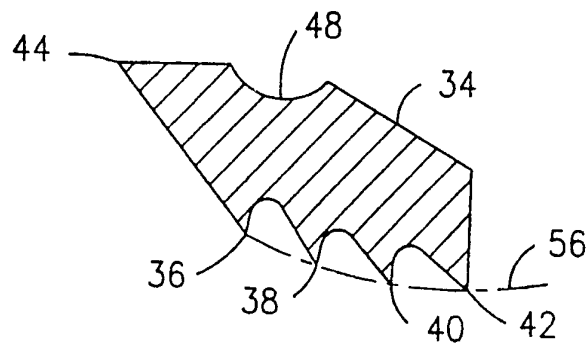

Fig. 4

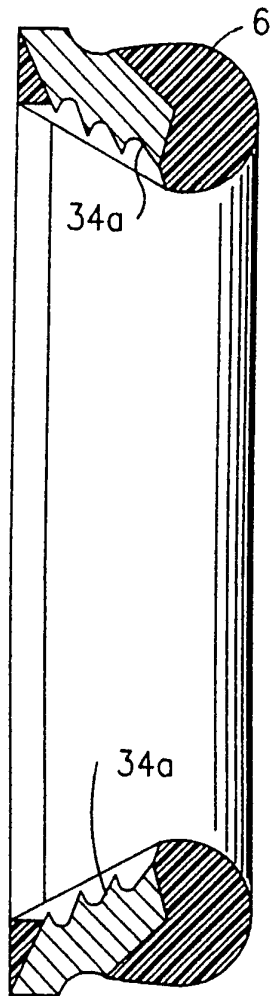

Fig. 5

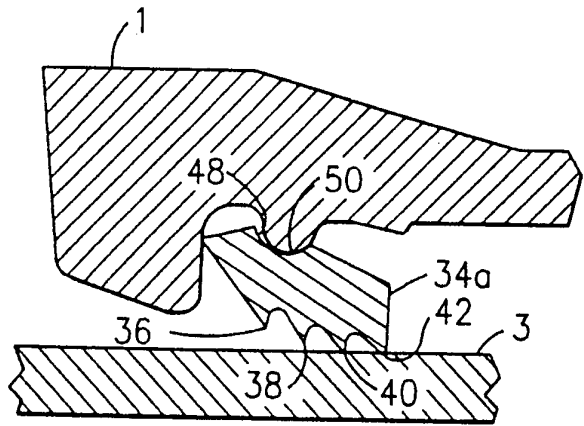

Fig. 6

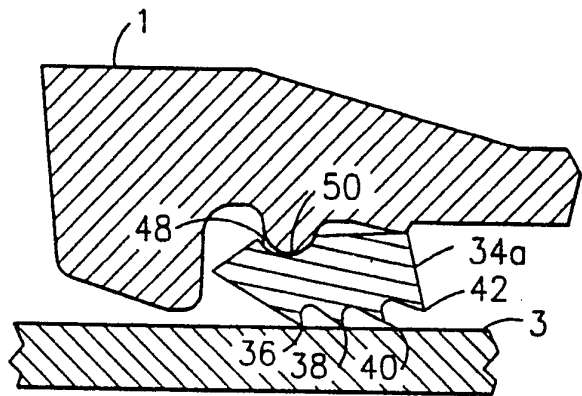

Fig. 7

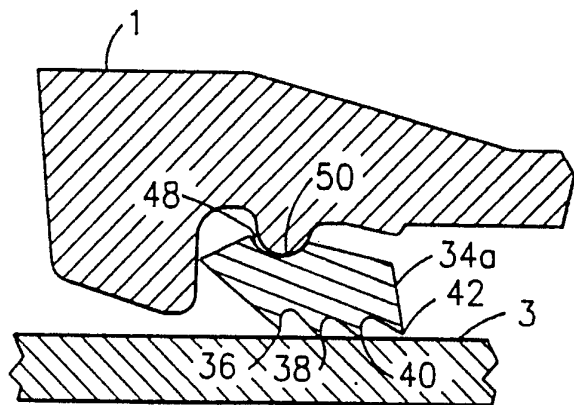

Fig. 8

INTERNATIONAL SEARCH REPORT

International application No.  
PCT/US94/09028

**A. CLASSIFICATION OF SUBJECT MATTER**

IPC(5) :F16L 17/00  
US CL :277/181

According to International Patent Classification (IPC) or to both national classification and IPC

**B. FIELDS SEARCHED**

Minimum documentation searched (classification system followed by classification symbols)

U.S. : 277/166, 181, 189, 207A; 285 104, 105, 231, 340, 343

Documentation searched other than minimum documentation to the extent that such documents are included in the fields searched

Electronic data base consulted during the international search (name of data base and, where practicable, search terms used)

**C. DOCUMENTS CONSIDERED TO BE RELEVANT**

Category*	Citation of document, with indication, where appropriate, of the relevant passages	Relevant to claim No.
X	US, A, 4,229,026 (Seiler) 21 October 1980, see figure 4.	1, 2, 3
Y	US, A, 5,094,467 (Lagabe) 10 March 1992, see figure 2	1-3
Y	US, A, 3,963,298 (Seiler) 15 June 1976, col 5, lines 47-52	1-3
Y	US, A, 5,067,751 (Walworth et al.) 26 November 1991, figure 2.	1-3

Further documents are listed in the continuation of Box C.  See patent family annex.

* Special categories of cited documents:	"T" later document published after the international filing date or priority date and not in conflict with the application but cited to understand the principle or theory underlying the invention
"A" document defining the general state of the art which is not considered to be of particular relevance	"X" document of particular relevance; the claimed invention cannot be considered novel or cannot be considered to involve an inventive step when the document is taken alone
"E" earlier document published on or after the international filing date	"Y" document of particular relevance; the claimed invention cannot be considered to involve an inventive step when the document is combined with one or more other such documents, such combination being obvious to a person skilled in the art
"L" document which may throw doubts on priority claim(s) or which is cited to establish the publication date of another citation or other special reason (as specified)	"&" document member of the same patent family
"O" document referring to an oral disclosure, use, exhibition or other means	
"P" document published prior to the international filing date but later than the priority date claimed	

Date of the actual completion of the international search  
02 NOVEMBER 1994

Date of mailing of the international search report  
**16 NOV 1994**

Name and mailing address of the ISA/US  
Commissioner of Patents and Trademarks  
Box PCT  
Washington, D.C. 20231

Authorized officer  
*For* DANIEL G. DEPUMPO

Facsimile No. (703) 305-3230

Telephone No. (703) 308-0771

*Sheela J...*  
Paralegal Specialist  
Group 2400

## INTERNATIONAL SEARCH REPORT

International application No.  
PCT/US94/09028**Box I Observations where certain claims were found unsearchable (Continuation of item 1 of first sheet)**

This international report has not been established in respect of certain claims under Article 17(2)(a) for the following reasons:

1.  Claims Nos.:  
because they relate to subject matter not required to be searched by this Authority, namely:
  
2.  Claims Nos.:  
because they relate to parts of the international application that do not comply with the prescribed requirements to such an extent that no meaningful international search can be carried out, specifically:
  
3.  Claims Nos.: 4 and 5  
because they are dependent claims and are not drafted in accordance with the second and third sentences of Rule 6.4(a).

**Box II Observations where unity of invention is lacking (Continuation of item 2 of first sheet)**

This International Searching Authority found multiple inventions in this international application, as follows:

1.  As all required additional search fees were timely paid by the applicant, this international search report covers all searchable claims.
2.  As all searchable claims could be searched without effort justifying an additional fee, this Authority did not invite payment of any additional fee.
3.  As only some of the required additional search fees were timely paid by the applicant, this international search report covers only those claims for which fees were paid, specifically claims Nos.:
  
4.  No required additional search fees were timely paid by the applicant. Consequently, this international search report is restricted to the invention first mentioned in the claims; it is covered by claims Nos.:

**Remark on Protest**

- The additional search fees were accompanied by the applicant's protest.  
 No protest accompanied the payment of additional search fees.