

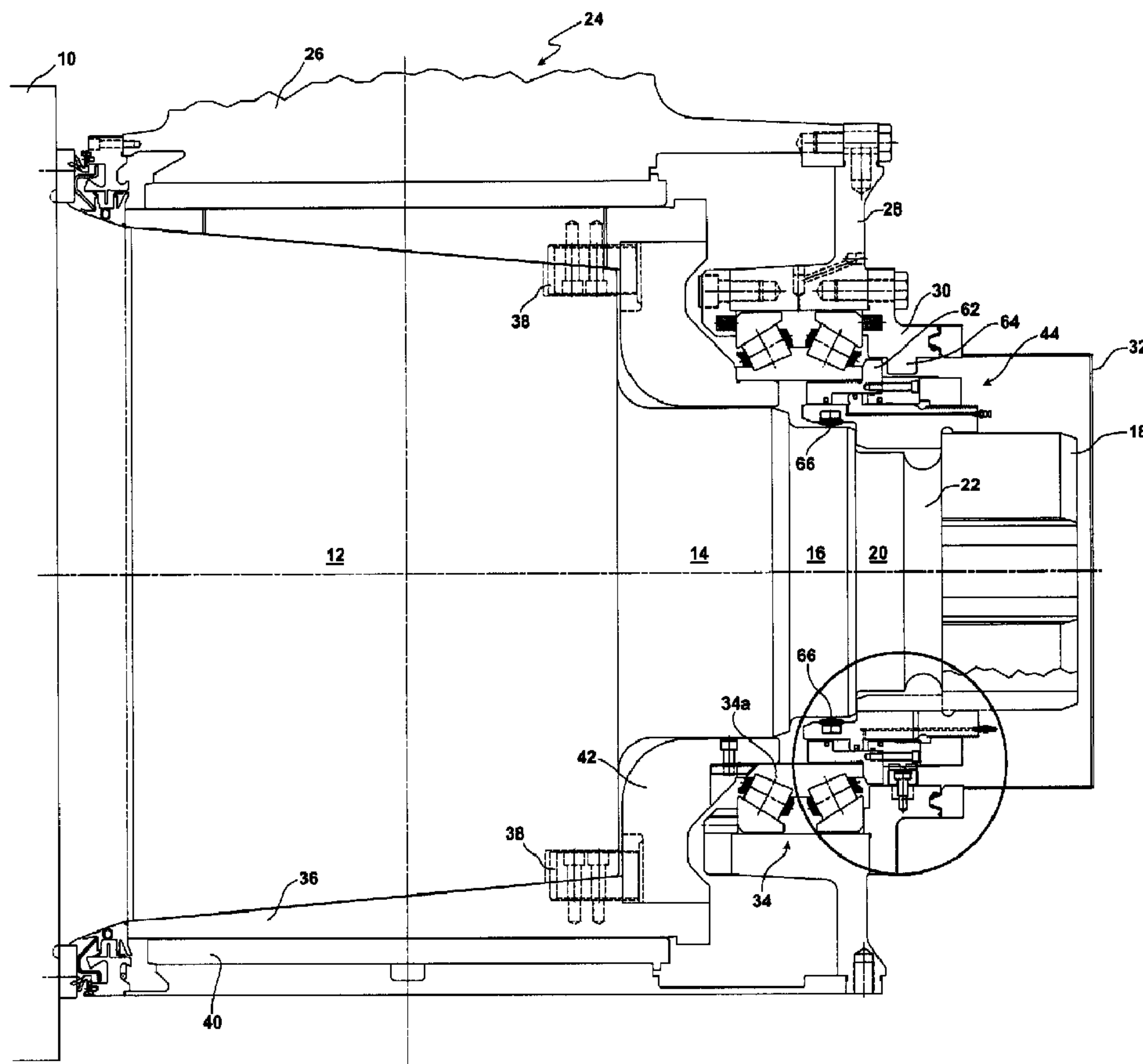

(22) Date de dépôt/Filing Date: 2007/12/19  
 (41) Mise à la disp. pub./Open to Public Insp.: 2008/07/31  
 (45) Date de délivrance/Issue Date: 2011/05/10  
 (30) Priorités/Priorities: 2007/01/31 (US60/887,419);  
 2007/12/17 (US11/957,563)

(51) Cl.Int./Int.Cl. *B21B 31/07* (2006.01),  
*F16C 23/08* (2006.01), *F16C 35/07* (2006.01)  
 (72) Inventeurs/Inventors:  
 OSGOOD, PETER N., US;  
 MARTINS, ARMANDO S., US;  
 WOJTKOWSKI, THOMAS C., JR., US;  
 JOHANSON, ERIC L., US;  
 DIVIRGILIO, RALPH, US  
 (73) Propriétaire/Owner:  
 SIEMENS INDUSTRY, INC., US  
 (74) Agent: SMART & BIGGAR

(54) Titre : PALIER A FILM D'HUILE POUR LAMINOIR  
 (54) Title: ROLLING MILL OIL FILM BEARING



(57) Abrégé/Abstract:

An oil film bearing assembly rotatably supports the neck of a roll in a rolling mill. The bearing assembly comprises a housing containing a sleeve bearing and a thrust bearing. A circular lock assembly coacts with the thrust bearing to axially retain the bearing

(57) **Abrégé(suite)/Abstract(continued):**

assembly on the roll neck. The lock assembly is axially received on and is rotatable into and out of mechanical interengagement with the roll neck. First bearing elements are carried by and project inwardly from the lock assembly to contact a surface of the roll neck at a first location, and second bearing elements project inwardly from the housing to contact an outer surface of the lock assembly at a second location spaced axially from the first location.

ABSTRACT

An oil film bearing assembly rotatably supports the neck of a roll in a rolling mill. The bearing assembly comprises a housing containing a sleeve bearing and a thrust bearing. A circular lock assembly coacts with the thrust bearing to axially  
5 retain the bearing assembly on the roll neck. The lock assembly is axially received on and is rotatable into and out of mechanical interengagement with the roll neck. First bearing elements are carried by and project inwardly from the lock assembly to contact a surface of the roll neck at a first location, and second bearing elements project inwardly from the housing to contact an outer surface of the lock assembly at  
10 a second location spaced axially from the first location.

## ROLLING MILL OIL FILM BEARING

### BACKGROUND OF THE INVENTION

#### 1. Field of the Invention

This invention relates generally to oil film bearings that are used to rotatably support  
5 the necks of rolls in a rolling mill.

#### 2. Description of the Prior Art

Rolling mill oil film bearings are typically held in place by lock assemblies that are  
rotated into and out of mechanical interengagement with the roll necks. In the larger size  
bearings, e.g., those with rolls measuring one and one half meters in diameter and larger,  
10 lock rotation requires relatively large clearances between the coating roll neck and lock  
assembly surfaces, which in turn gives rise to a tendency of the lock assemblies to tilt,  
misalign, and bind during mounting and dismounting. This problem is further exacerbated  
by the weight of the larger lock assemblies, which can exceed 900 kilograms.

The objective of the present invention is to ease the task of rotating the lock  
15 assemblies into and out of mechanical interengagement with the roll necks by incorporating  
strategically placed bearings that encourage proper alignment while avoiding the tendency  
of the lock assemblies to tilt and bind.

### SUMMARY OF THE INVENTION

In accordance with an aspect of the present invention, there is provided an oil film  
20 bearing for rotatably supporting the neck of a roll in a rolling mill, the bearing comprising: a  
housing containing a sleeve bearing and a thrust bearing; a circular lock assembly coating  
with the thrust bearing to axially retain the bearing on the roll neck, the lock assembly being  
axially received on and rotatable into and out of mechanical interengagement with the roll  
neck; first bearing elements carried by and projecting inwardly from the lock assembly to

contact a surface of the roll neck at a first location; and second bearing elements projecting inwardly from the housing to contact an outer surface of the lock assembly at a second location spaced axially from the first location, wherein the first and second bearing elements coact to resist titling of the lock assembly.

5           In accordance with an exemplary embodiment of the present invention, an oil film bearing comprises a chock and associated end plates forming a housing that contains both sleeve bearing and thrust bearing components. A circular lock assembly coacts with the thrust bearing component to axially retain the oil film bearing on the roll neck. The lock assembly is rotatable into and out of mechanical interengagement with the roll neck. First  
10 bearing elements are carried by and project inwardly from the lock assembly to contact a surface of the roll neck at a first location. Second bearing elements project

inwardly from a chock end plate of the housing to contact an outer surface of the lock assembly at a second location spaced axially from the first location. The first and second bearing elements encourage proper alignment of the lock assembly on the roll neck, thus avoiding or at least significantly minimizing the tendency of the lock assembly to tilt and bind during mounting and dismounting.

#### BRIEF DESCRIPTION OF THE DRAWINGS

Figure 1 is a longitudinal sectional view taken through an oil film bearing embodying the concepts of the present invention;

Figure 2 is an enlarged view of the circled portion of Figure 1;

Figure 3 is a sectional view taken along line 3-3 of Figure 2;

Figure 4 is a horizontal plan view of the components shown in Figure 3;

Figures 5 and 7, and 6 and 8 are respectively views similar to Figures 3 and 4, depicting alternative embodiments of the invention; and

Figures 9A and 9B are schematic illustrations depicting successive stages in achieving interlocked engagement of the lock assembly with the roll neck.

#### DETAILED DESCRIPTION OF ILLUSTRATED EMBODIMENTS

With reference initially to Figure 1, a rolling mill roll 10 has a tapered section 12 leading to an end having reduced diameter cylindrical intermediate sections 14, 16, the latter being separated from a cylindrical end section 18 by cylindrical section 20 and circular groove 22. An oil film bearing 24 includes a chock 26 cooperating with end plates 28 and 30 and a cover 32 to define a housing containing a thrust bearing 34 and a sleeve bearing comprised of a sleeve 36 rotatably fixed to the tapered neck section 12 by keys 38, with the sleeve in turn being rotatably journalled in a bushing 40 fixed within the chock 26.

A thrust ring 42 is interposed between the sleeve 36 and thrust bearing 34, and a lock assembly 44 coacts with the inner race 34a of the thrust bearing 34 to axially retain the oil film bearing on the roll neck.

As can best be seen by further reference to Figure 2, the lock assembly 44 includes a piston 46 surrounded by a cylinder 48 comprised of mating ring-shaped components 48a, 48b interconnected by fasteners 50. The cylinder 48 defines an interior space subdivided by a piston ring 52 into chambers 54a, 54b.

The piston 46 is interengaged with the roll neck by means of a bayonet-type connection. More particularly, with reference to Figure 9A, the piston 46 has inwardly projecting splines 46a angularly separated by grooves 46b, and the roll end section 18 has complimentary outwardly projecting splines 18a angularly separated by grooves 18b. In Figure 9A, the piston splines 46a are aligned axially with the neck grooves 18b and the piston grooves 46b are aligned with the neck splines 18a, thus allowing the lock assembly to be axially mounted on an removed from the roll neck. As shown in Figure 9B, a 45° rotation of the lock assembly will result in the piston splines 46a being aligned with the roll neck splines 18a, thus establishing an interlocked interengagement which axially fixes the lock assembly 44 relative to the roll neck.

Once the lock assembly is fixed axially on the roll neck, hydraulic fluid can be introduced into cylinder chamber 54a to urge the cylinder 48 to the left as viewed in Figures 1 and 2, thus urging the thrust bearing 34 in the same direction to seat the oil film bearing on the roll neck. Thereafter, a lock nut 58 threaded as at 60 on piston 46 is tightened to axially retain the cylinder in place, allowing the hydraulic pressure in chamber 54a to be relieved.

Removal of the oil film bearing is accomplished by first loosening the lock nut 58 and then hydraulically pressurizing chamber 54b, causing the cylinder 48 to move

to the right as viewed in Figures 1 and 2. An external shoulder 62 on the cylinder then coacts with an interior ring 64 of outer end plate 30 (see Figure 1) to axially dislodge the oil film bearing from the roll neck.

As previously noted, during mounting and dismounting of the oil film bearing, the lock assembly 44 has a tendency to tilt and bind. To resist this tendency, first ball-type bearing elements 66 are carried by and project inwardly from the piston 46 to contact the reduced diameter section 16 of the roll neck at a first location. Second roller-type bearing elements 68 project inwardly from the outer end plate 30 to contact the outer surface of the cylinder component 48b at a second location spaced axially from the first location contacted by the first bearing elements. The first and second bearing elements 66, 68 coact to resist tilting of the lock assembly, thus avoiding binding as it rotates into and out of interlocked engagement with the roll neck.

As shown in Figures 3 and 4, the roller-type bearing elements 68 may be carried on an arcuate platform 70 urged radially inwardly by resilient force exerting means in the form of springs 72. Alternatively, as shown in Figures 5 and 6, the arcuate platform can be urged radially inwardly by hydraulically actuated means in the form of a piston 74.

In still another embodiment, as shown in Figures 7 and 8, the roller-type bearing elements 68 can simply be located in pockets 76 and rotatably supported on pins 78 fixed with respect to the chock end plate 30.

We Claim:

1. An oil film bearing for rotatably supporting the neck of a roll in a rolling mill, said bearing comprising:
  - a housing containing a sleeve bearing and a thrust bearing;
  - a circular lock assembly coacting with said thrust bearing to axially retain said bearing on said roll neck, said lock assembly being axially received on and rotatable into and out of mechanical interengagement with said roll neck;
  - first bearing elements carried by and projecting inwardly from said lock assembly to contact a surface of said roll neck at a first location; and
  - second bearing elements projecting inwardly from said housing to contact an outer surface of said lock assembly at a second location spaced axially from said first location,wherein said first and second bearing elements coact to resist titling of the lock assembly.
2. The oil film bearing of claim 1 wherein said first bearing elements comprise ball-type bearings.
3. The oil film bearing of claim 1 or claim 2 wherein said second bearing elements comprise roller-type bearings.
4. The oil film bearing of claim 3 wherein said second bearing elements are urged radially inwardly by resilient force exerting means.
5. The oil film bearing of claim 4 wherein said second bearing elements are carried on an arcuate platform acted upon by said resilient force exerting means.
6. The oil film bearing of claim 1 or claim 2 wherein said second bearing elements are urged radially inwardly by hydraulically actuated means.

7. The oil film bearing of claim 6 wherein said second bearing elements are carried on an arcuate platform acted upon by said hydraulically actuated means.
8. The oil film bearing of any one of claims 1 to 7 wherein said lock assembly is mechanically interengaged with said roll neck by means of a bayonet-type connection.
9. The oil film bearing of any one of claims 1 to 8 wherein said circular lock assembly comprises a piston adapted to be mechanically interengaged with said roll neck, and a cylinder surrounding said piston, said first bearing elements being carried by and projecting inwardly from said piston, and said second bearing elements being carried by and projecting inwardly from a component of said housing.

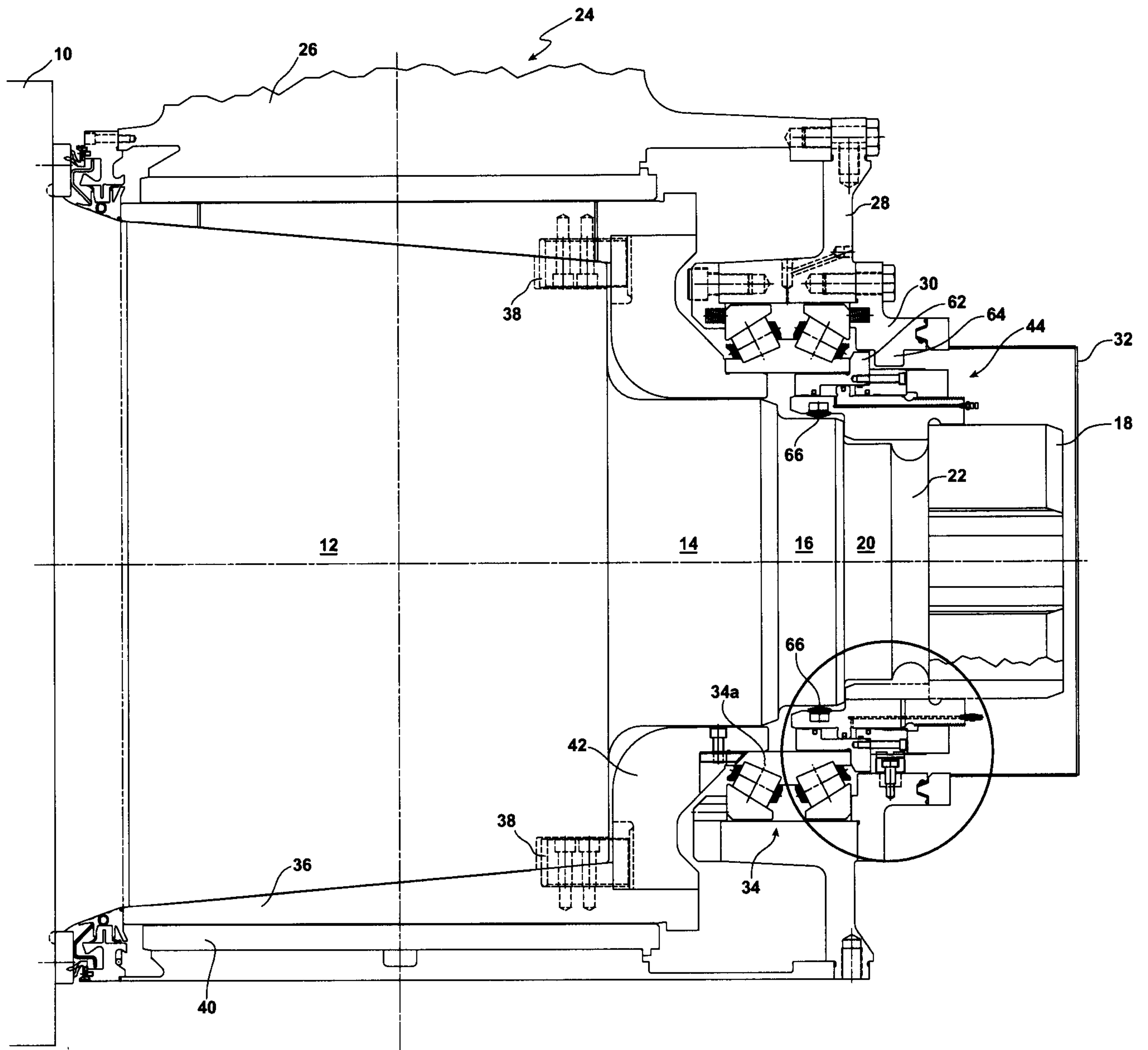

FIG. 1

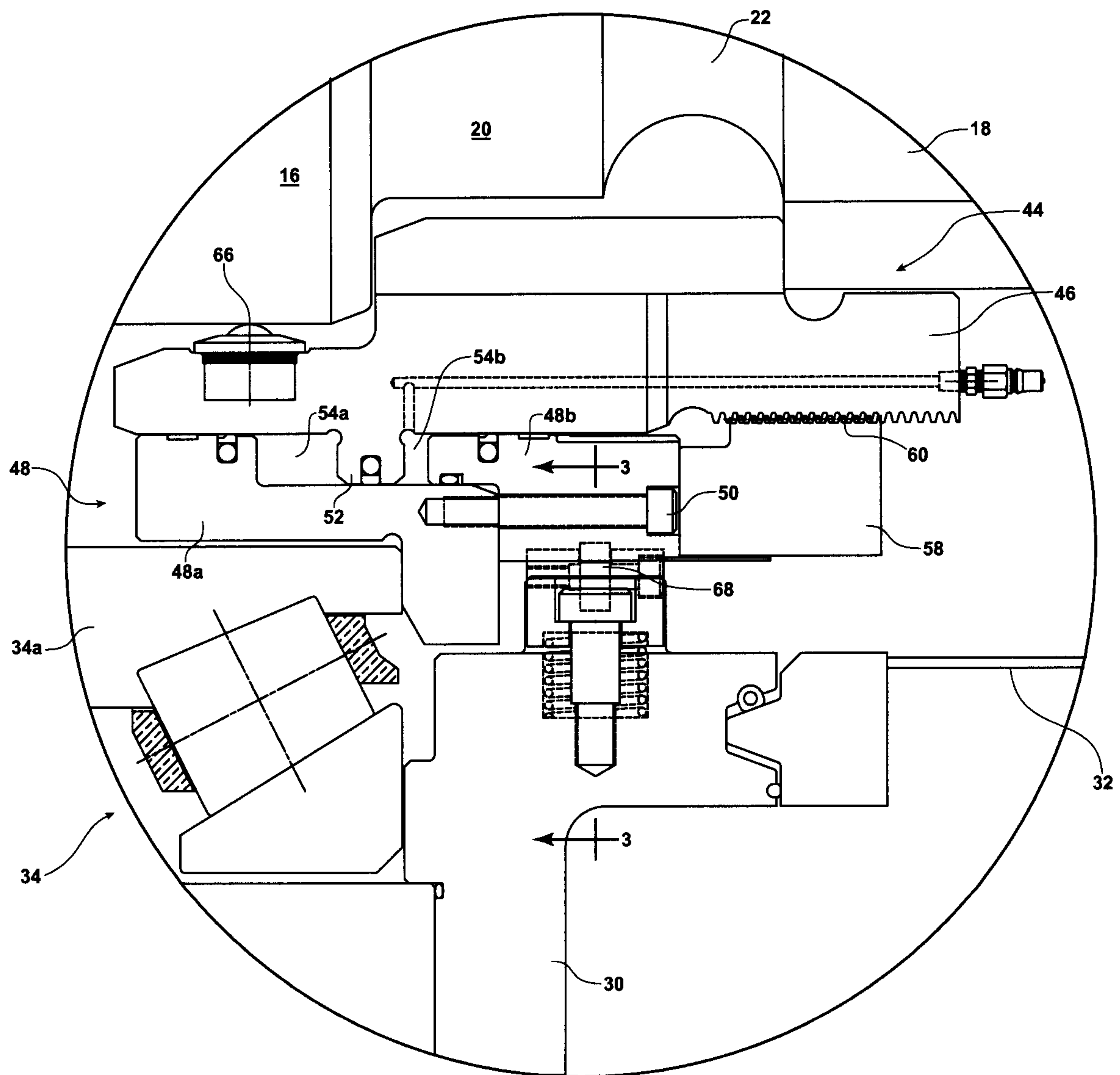

FIG. 2

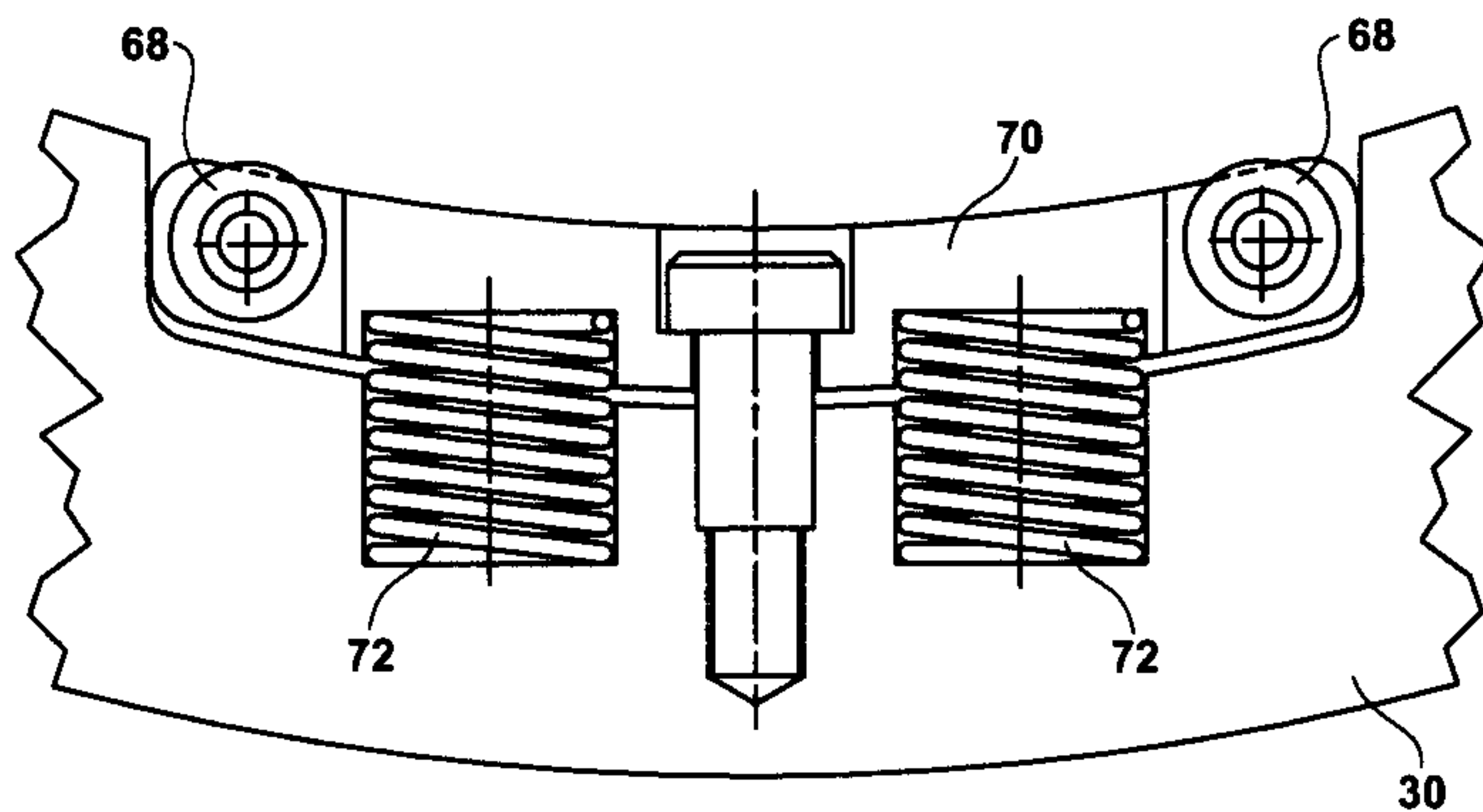

FIG. 3

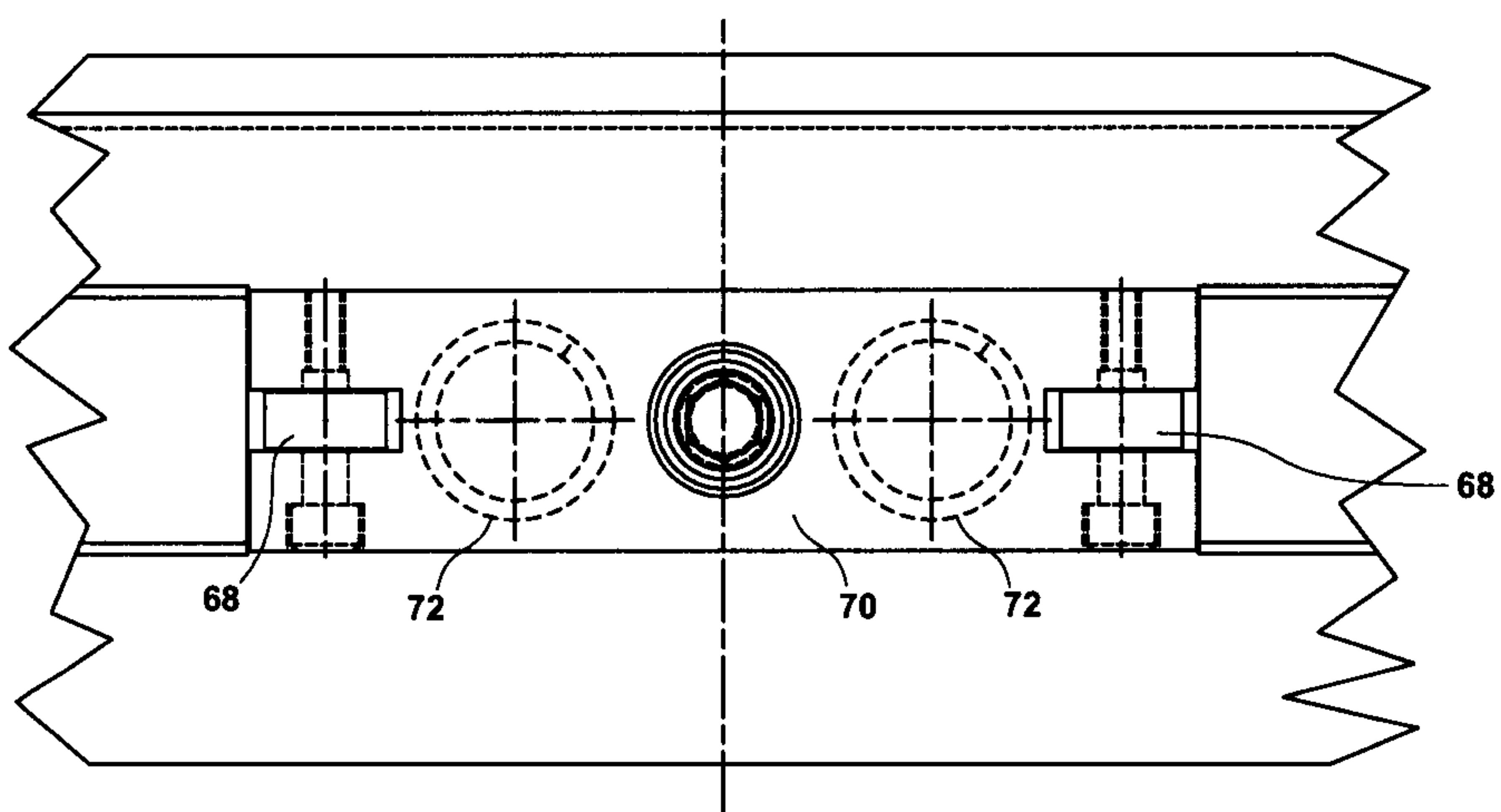

FIG. 4

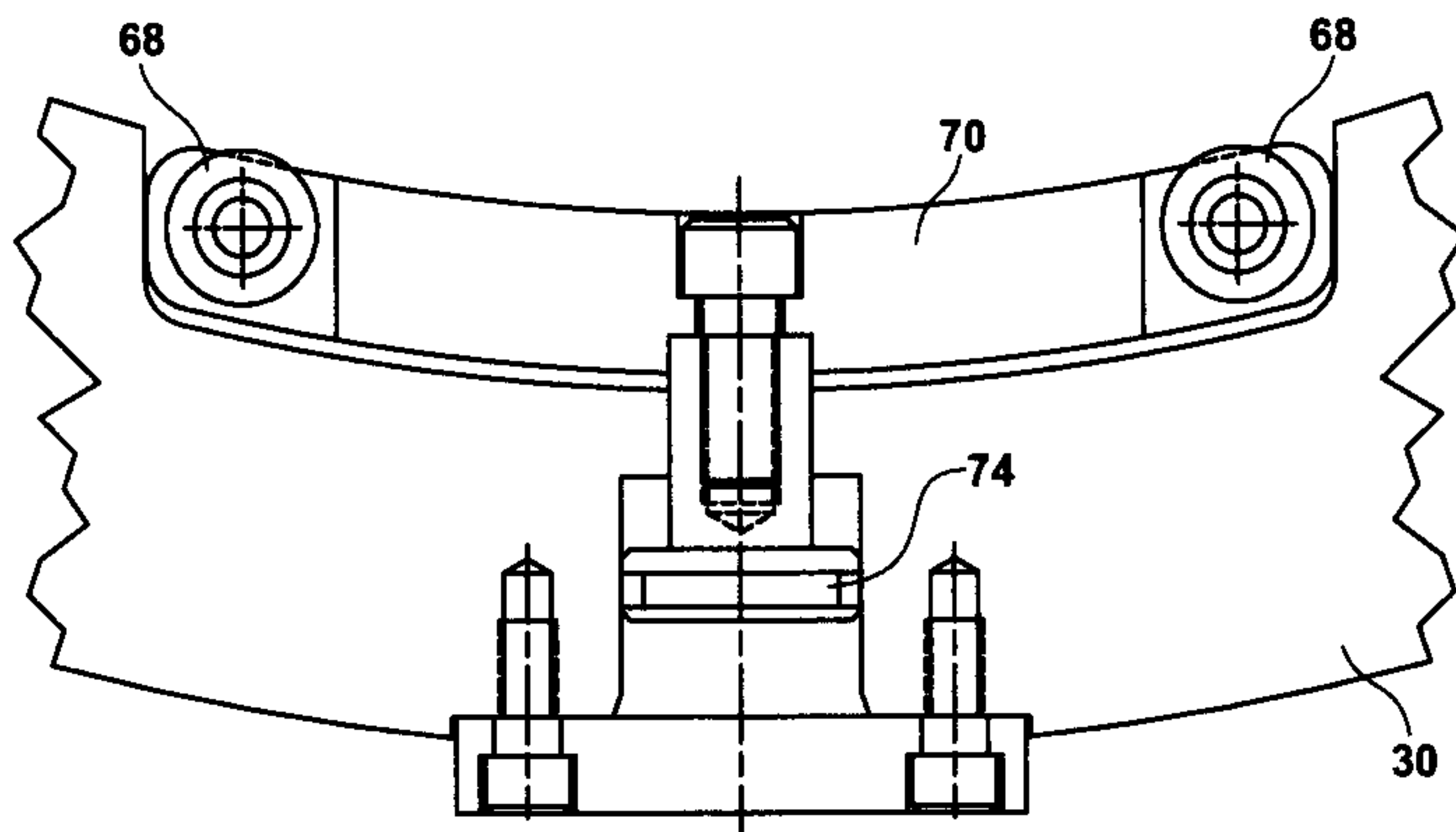

FIG. 5

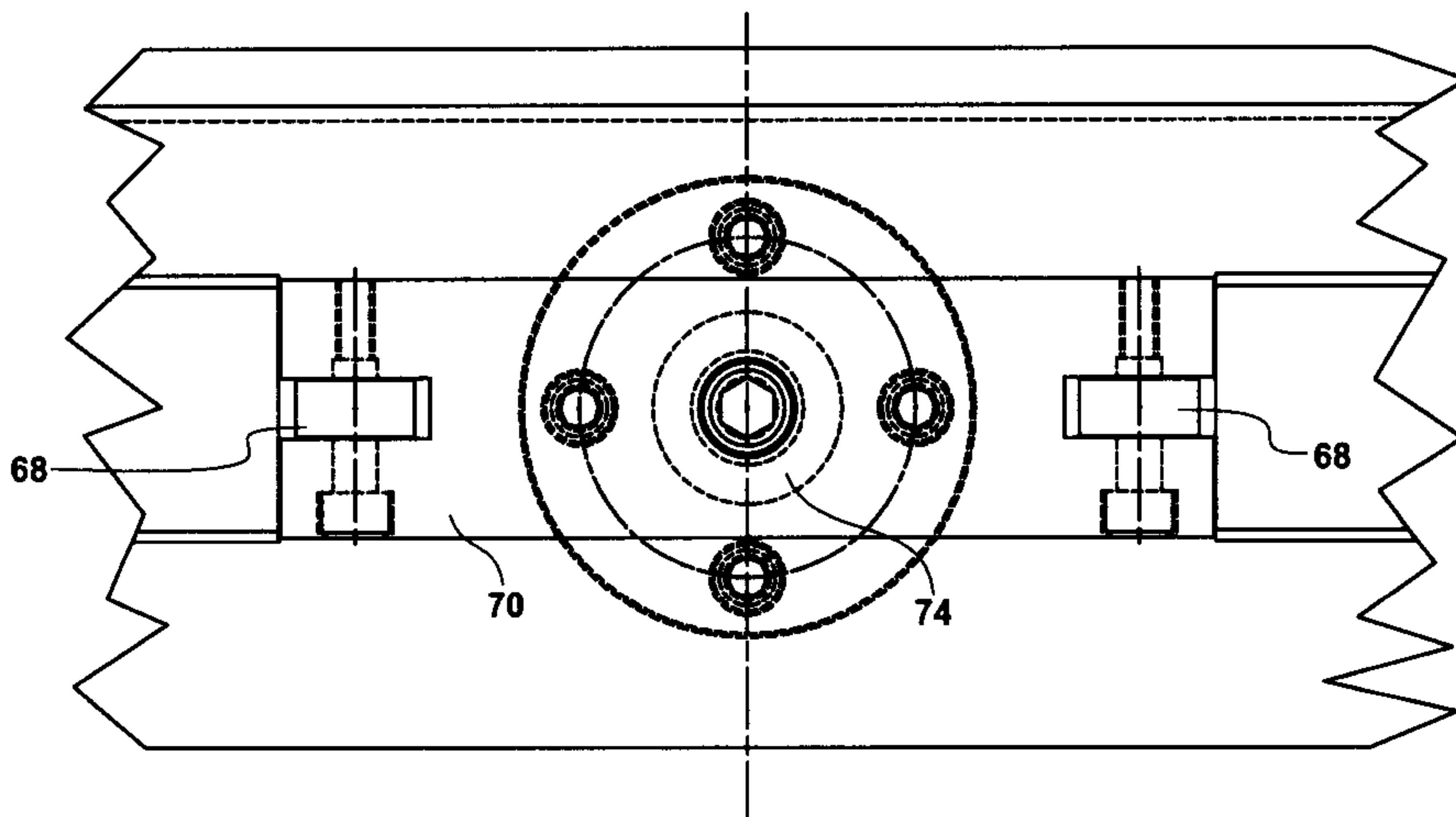

FIG. 6

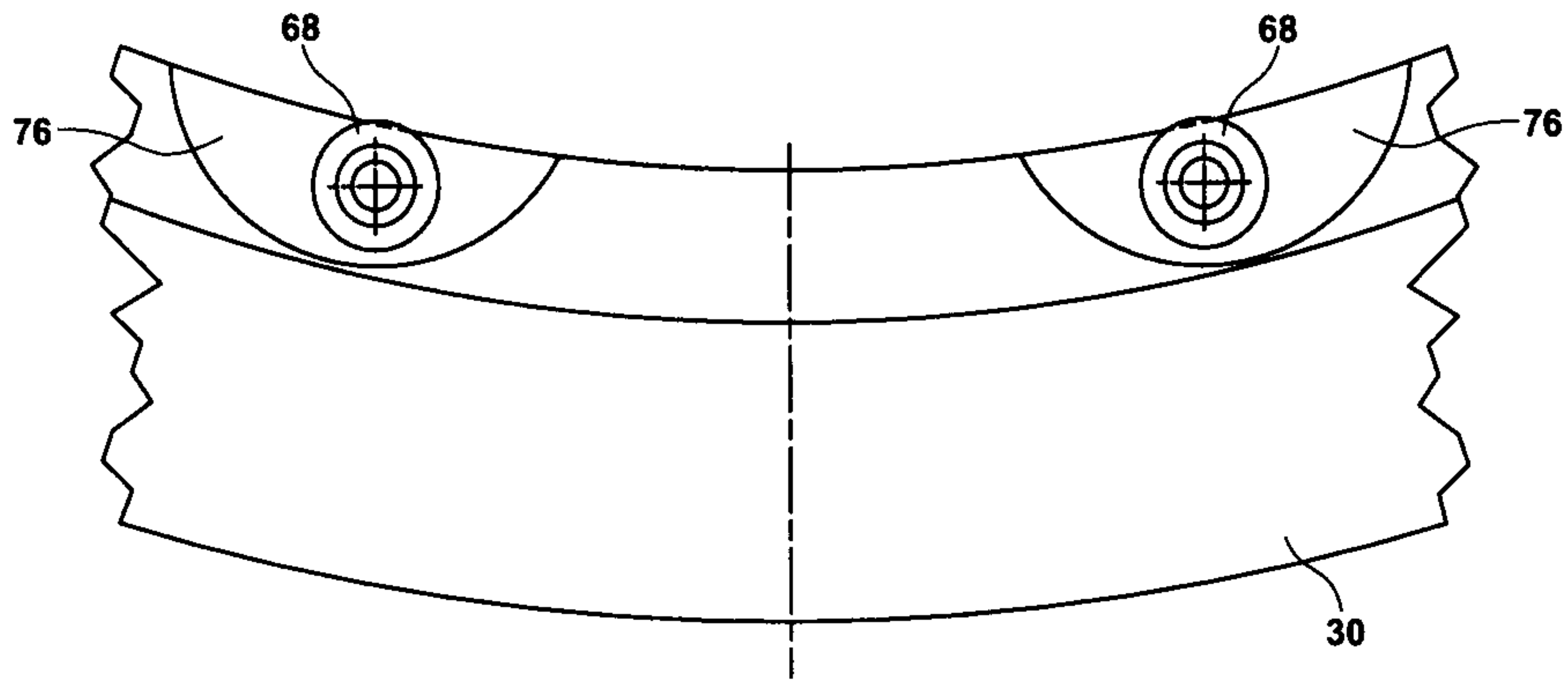

FIG. 7

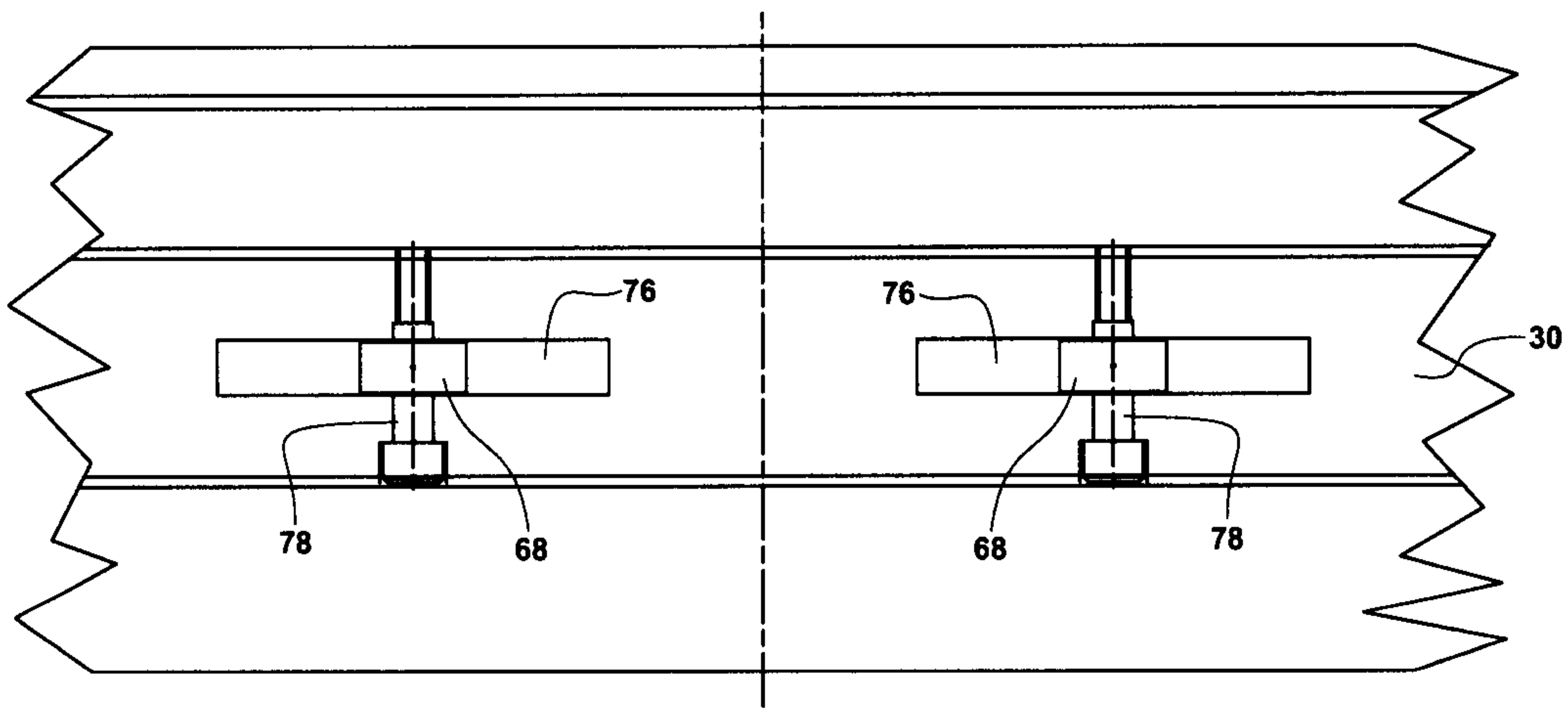

FIG. 8

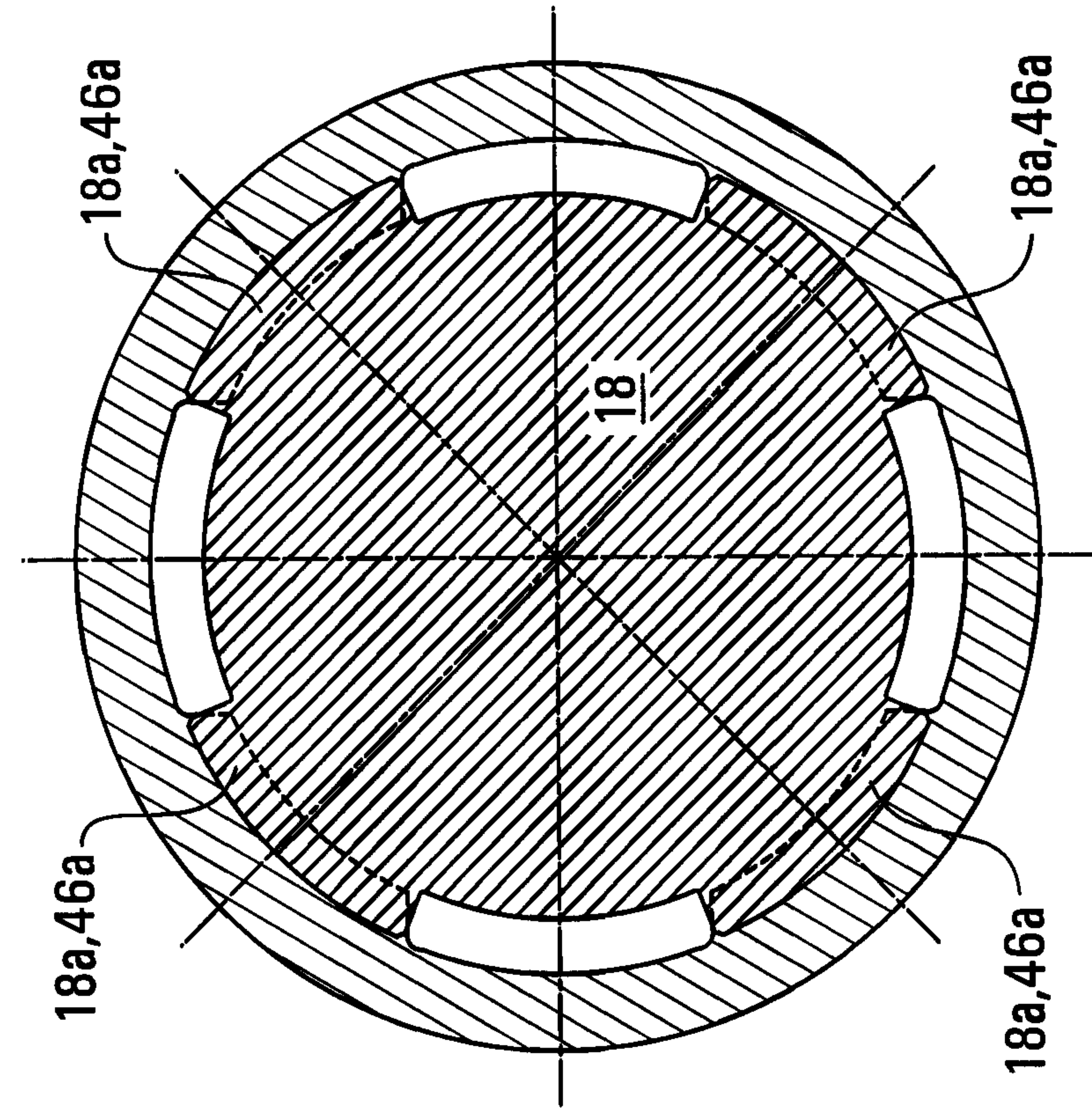

FIG. 9a

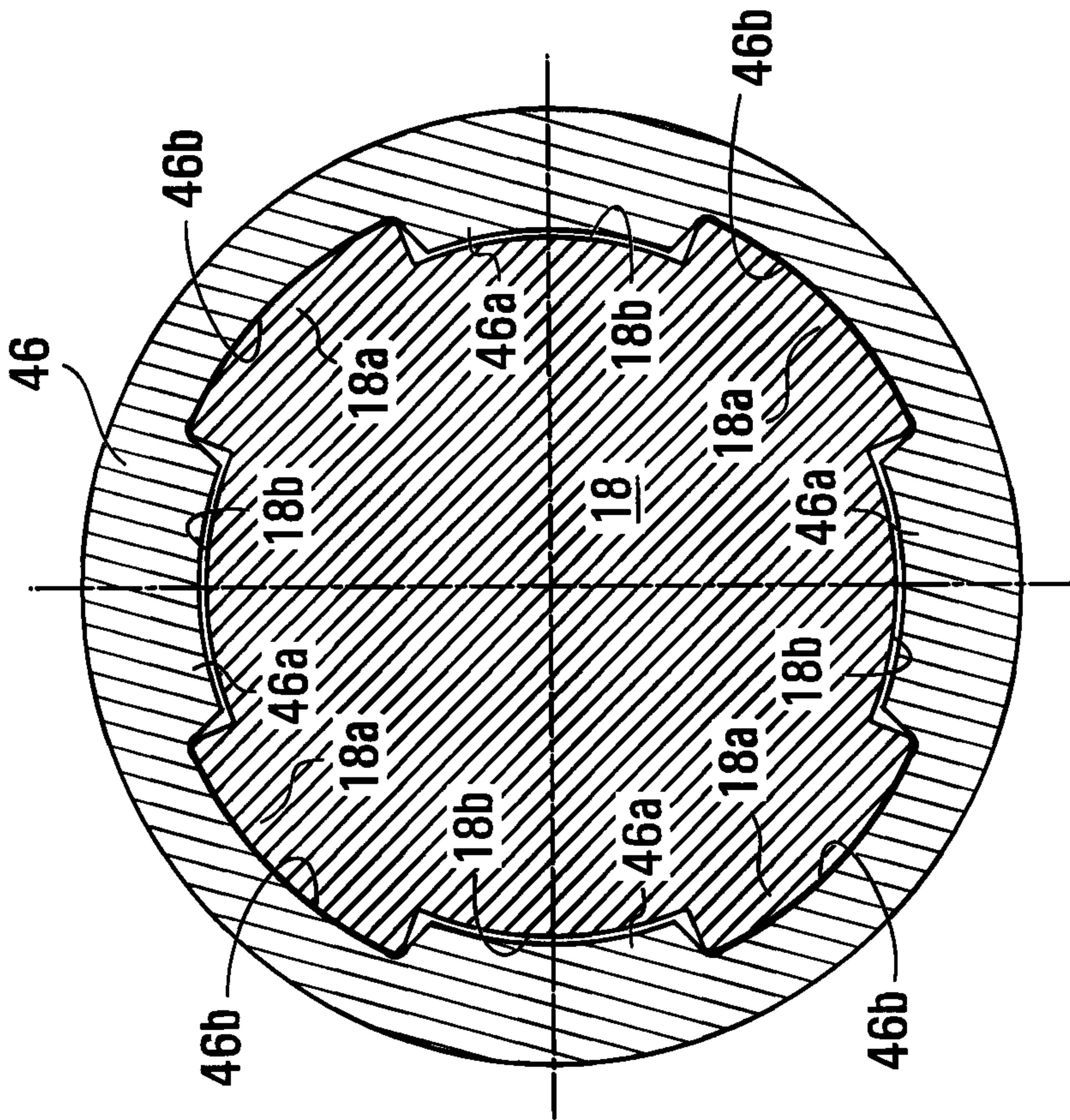

FIG. 9b

