

No. 679,626.

Patented July 30, 1901.

A. E. LEACH.
STERILIZING APPARATUS.

(Application filed June 30, 1900.)

(No Model.)

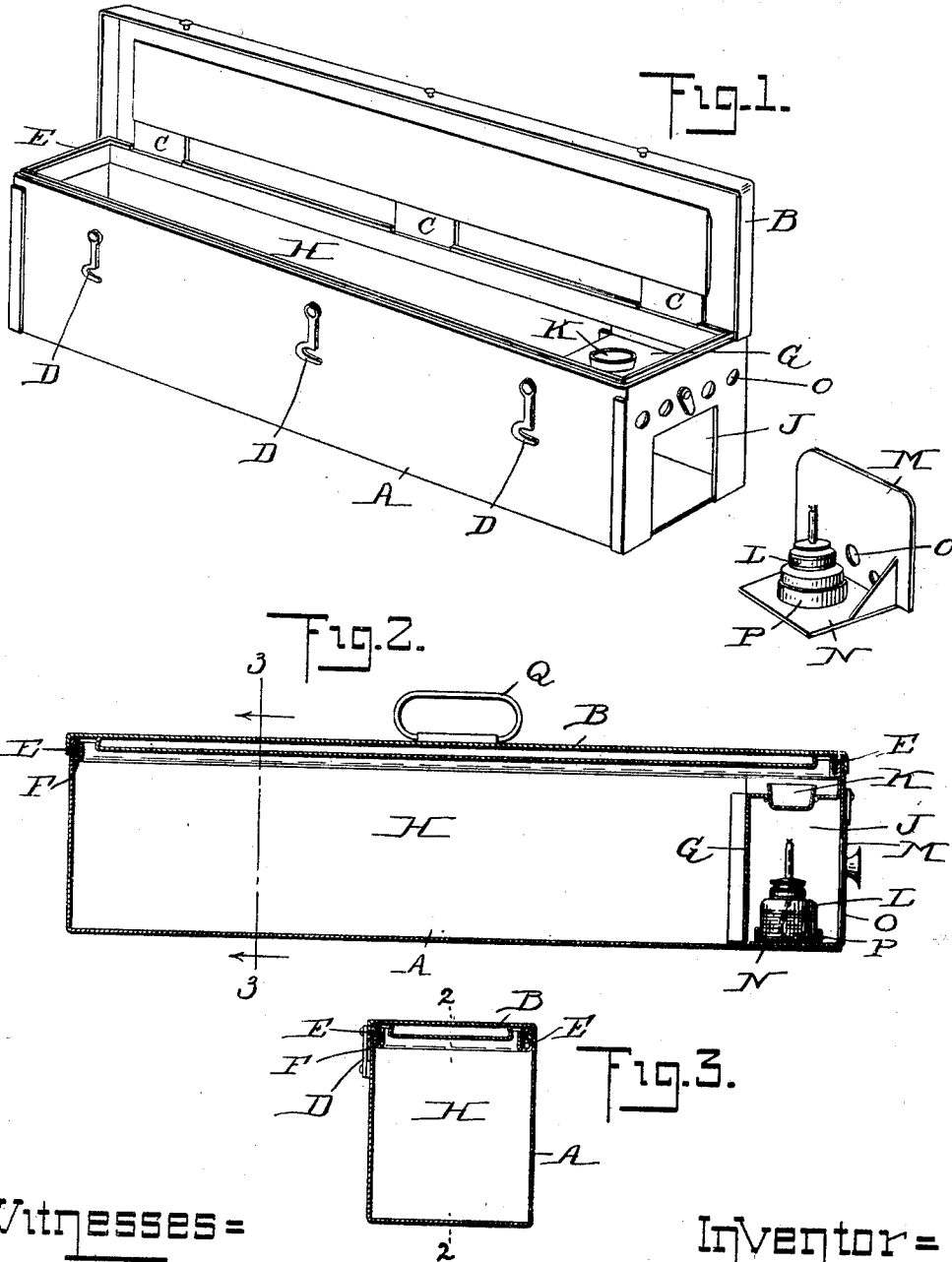

Witnesses=

Charles F. Logan.
M. C. P. Over.

Inventor=

Arthur E. Leach
by A. O. Jensen,
Atty.

UNITED STATES PATENT OFFICE.

ARTHUR E. LEACH, OF WINTHROP, MASSACHUSETTS.

STERILIZING APPARATUS.

SPECIFICATION forming part of Letters Patent No. 679,626, dated July 30, 1901.

Application filed June 30, 1900. Serial No. 22,240. (No model.)

To all whom it may concern:

Be it known that I, ARTHUR E. LEACH, of Winthrop, in the county of Suffolk and State of Massachusetts, have invented certain new and useful Improvements in Sterilizing Apparatus, of which the following is a specification.

The object of this invention is to furnish improved means for sterilizing surgical and obstetrical instruments and tools used by oculists, aurists, and dentists.

My improved sterilizer is a compact self-contained apparatus consisting of a box or casing, preferably rectangular and horizontally elongated, provided with a close-fitting hinged cover and fastenings therefor, yielding impervious packing being interposed between the box and cover to secure gas-tight joints. The packings are preferably arranged edgewise in narrow vertical pockets along the edges of the box-body and formed by a fold of the metal at the top of the walls. The lamp-chamber is within the box-body and is separated from the sterilizing-chamber by a partition shown as having a vertical and a horizontal portion, the latter having a circular opening through it, forming a central socket over the lamp, in which a shallow tapering platinized cup fits to receive one or more tablets or pastels of formaldehyde or the like to be vaporized speedily by the heat of the lamp. An ordinary alcohol-lamp, of glass, may be used, the box having an end opening to permit insertion or removal of the lamp without escape of gas from the box proper. The slide or door closing this end opening has perforations making the lamp-light visible and serving to admit air to the lamp-chamber to support combustion. A lamp-carrying slide is connected to the foot of the door, and a low fender may be provided thereon to keep the lamp in proper position. The box-cover has two or more hinges or one practically continuous hinge at one edge and substantial hook or other fastenings at the opposite edge, by which it is held down upon the packings firmly and readily released. A folding or other handle is attached to the cover centrally.

In use the tools or other articles to be ster-

ilized are placed in the box on trays or otherwise, where they may remain indefinitely exposed to the formaldehyde gas or other disinfectant; but they will be effectually sterilized in a few minutes by use of my apparatus, as described.

In the drawings, Figure 1 is a perspective view of my apparatus, showing the cover opened and the lamp and its carrying-slide removed from the lamp-chamber. Fig. 2 is a longitudinal section, and Fig. 3 a transverse section, through the closed box, taken, respectively, on line 2 2 of Fig. 3 and line 3 3 of Fig. 2.

A represents the walls, and B the cover, of the box, connected by stout hinges C and furnished with hooks D or equivalent fastenings, engaging studs on the edge of the cover opposite to such hinges. Suitable impervious packings are provided at the junction of the box and cover, all around, the packing-strips E being shown as set vertically in narrow pockets F, which may be formed by a fold of the metal at the upper edge of the walls. These packings render the box practically gas-tight, and by preventing escape of the gas they greatly promote the sterilizing action therein.

G is a partition, shown as having a vertical and a horizontal portion dividing the interior of the box into the sterilizing-chamber H and the lamp-chamber J. The horizontal part of such partition has a central opening or seat provided with a close-fitting shallow metal cup K to contain the tablet or material which when vaporized fills the chamber H and sterilizes or disinfects the instruments placed therein. The vapors are confined within said chamber H by the packed joints of the cover.

L represents a suitable lamp located in the chamber J beneath the cup K. The lamp is introduced and removed through the end of said chamber J, the removable door M having a horizontal foot or slide N, on which the lamp rests, a low fender P serving to locate it properly. Air-holes O are formed through the end or door to support combustion and make the lamp-light visible. The lamp can be trimmed, lighted, extinguished, or re-

moved without opening the sterilizing-chamber. A folding handle Q is attached to the cover for convenience in carrying the box.

I claim as my invention—

5 1. The described sterilizing apparatus, comprising a close-covered rectangular box or case partitioned to form a distinct lamp-chamber and sterilizing-chamber, said partition
10 having an opening through it forming a socket for the tablet-cup and said lamp-chamber having an aperture for insertion and removal
of the lamp without opening the box proper, substantially as set forth.

15 2. In a sterilizing apparatus, a box or case horizontally elongated and having a partition dividing its interior into two distinct chambers, the lamp-chamber at one end of said

box being provided with a lamp and furnished with a suitable closure adapted to carry and locate the lamp, and the sterilizing-chamber having a close-fitting cover with hinges along one edge, fastenings at the opposite edge and impervious packings at the joints, whereby the vapors generated from the sterilizing substance by the heat of the lamp are confined and made effective upon the instruments inclosed in the sterilizing-chamber, substantially as set forth.

In testimony whereof I have affixed my signature in presence of two witnesses.

ARTHUR E. LEACH.

Witnesses:

A. H. SPENCER,
NATHL. GREENE.