

(19)



Europäisches Patentamt  
European Patent Office  
Office européen des brevets



(11)

**EP 0 847 672 B1**

(12)

**EUROPEAN PATENT SPECIFICATION**

(45) Date of publication and mention of the grant of the patent:  
**10.03.1999 Bulletin 1999/10**

(51) Int Cl.<sup>6</sup>: **H04R 7/06**, B65D 79/00,  
B65D 81/36

(21) Application number: **96929391.9**

(86) International application number:  
**PCT/GB96/02146**

(22) Date of filing: **02.09.1996**

(87) International publication number:  
**WO 97/09855 (13.03.1997 Gazette 1997/12)**

**(54) PACKAGING**

VERPACKUNG

MISE SOUS ENCEINTE

(84) Designated Contracting States:  
**AT BE CH DE DK ES FI FR GB GR IE IT LI LU MC  
NL PT SE**  
Designated Extension States:  
**AL LT LV SI**

- **COLLOMS, Martin**  
London NW2 2DA (GB)
- **HARRIS, Neil**  
Cambridge CB2 5JF (GB)

(30) Priority: **02.09.1995 GB 9517918**  
**31.10.1995 GB 9522281**  
**30.03.1996 GB 9606836**

(74) Representative: **Maguire, Peter Albert et al**  
**Maguire Boss,**  
**5 Crown Street**  
**St. Ives, Cambridgeshire PE17 4EB (GB)**

(43) Date of publication of application:  
**17.06.1998 Bulletin 1998/25**

(56) References cited:  
**EP-A- 0 034 024**                      **WO-A-92/03024**  
**DE-A- 3 706 014**                      **GB-A- 2 010 637**  
**US-A- 3 247 925**                      **US-A- 4 352 961**  
**US-A- 4 607 747**                      **US-A- 5 025 474**  
**US-A- 5 387 108**

(73) Proprietor: **New Transducers Limited**  
**Huntingdon, Cambridgeshire PE18 6ED (GB)**

(72) Inventors:  
• **AZIMA, Henry**  
**Cambridge CB2 2TT (GB)**

**EP 0 847 672 B1**

Note: Within nine months from the publication of the mention of the grant of the European patent, any person may give notice to the European Patent Office of opposition to the European patent granted. Notice of opposition shall be filed in a written reasoned statement. It shall not be deemed to have been filed until the opposition fee has been paid. (Art. 99(1) European Patent Convention).

**Description**TECHNICAL FIELD

[0001] The invention relates to packaging and more particularly to packaging incorporating loudspeakers.

BACKGROUND ART

[0002] It is known from GB-A-2262861 to suggest a panel-form loudspeaker comprising:-

a resonant multi-mode radiator element being a unitary sandwich panel formed of two skins of material with a spacing core of transverse cellular construction, wherein the panel is such as to have ratio of bending stiffness (B), in all orientations, to the cube power of panel mass per unit surface area ( $\mu$ ) of at least 10;

a mounting means which supports the panel or attaches to it a supporting body, in a free undamped manner;

and an electro-mechanical drive means coupled to the panel which serves to excite a multi-modal resonance in the radiator panel in response to an electrical input within a working frequency band for the loudspeaker.

[0003] US-A-4,607,747 of STEINER discloses packaging comprising means for generating a signal or melody when opening the packaging. A resiliently mounted signal generator is disclosed.

DISCLOSURE OF INVENTION

[0004] Embodiments of the present invention use members of nature, structure and configuration achievable generally and/or specifically by implementing teachings of our co-pending PCT publication No. W097/09842 of even date herewith. Such members thus have capability to sustain and propagate input vibrational energy by bending waves in operative area(s) extending transversely of thickness often but not necessarily to edges of the member(s); are configured with or without anisotropy of bending stiffness to have resonant mode vibration components distributed over said area(s) beneficially for acoustic coupling with ambient air; and have predetermined preferential locations or sites within said area for transducer means, particularly operationally active or moving part(s) thereof effective in relation to acoustic vibrational activity in said area(s) and signals, usually electrical, corresponding to acoustic content of such vibrational activity. Uses are envisaged in co-pending International publication No. W097/09842 for such members as or in "passive" acoustic devices without transducer means, such as for reverberation or for acoustic filtering or for acoustically "voicing" a space or room; and as or in "active" acoustic

devices with transducer means, such as in a remarkably wide range of sources of sound or loudspeakers when supplied with input signals to be converted to said sound, or in such as microphones when exposed to sound to be converted into other signals.

[0005] This invention is particularly concerned with packaging incorporating acoustic devices e.g. in the form of loudspeakers. The term 'packaging' is intended to encompass containers generally whether or not they are disposable.

[0006] Members as above are herein called distributed mode radiators and are intended to be characterised as in the above PCT application and/or otherwise as specifically provided herein.

[0007] The invention is packaging comprising a sound generator, characterised by a board component forming a part of the packaging and acting as a member having capability to sustain and propagate input vibrational energy by bending waves in at least one operative area extending transversely of thickness to have resonant mode vibration components distributed over said at least one area and have predetermined preferential locations or sites within said area for transducer means and having a transducer mounted wholly and exclusively on said member at one of said locations or sites to vibrate the member to cause it to resonate forming an acoustic radiator which provides an acoustic output when resonating. The member may comprise a cellular core sandwiched between skin layers. The member may comprise a core of foamed plastics sandwiched between sheets of craft board. The transducer may be a piezo-electric bender, and the bender may be crystalline. The member may form one side of a box. The box may have a lid, and means associated with the lid for triggering actuation of the transducer on movement of the lid relative to the box. The packaging may comprise a signal generator, an amplifier and an electric battery to drive the transducer.

BRIEF DESCRIPTION OF DRAWINGS

[0008] The invention is diagrammatically illustrated, by way of example, in the accompanying drawings, in which:-

Figure 1 is a diagram showing a distributed-mode loudspeaker as described and claimed in our co-pending International publication No. W097/09842; Figure 2a is a partial section on the line A-A of Figure 1;

Figure 2b is an enlarged cross-section through a distributed mode radiator of the kind shown in Figure 2a and showing two alternative constructions; Figure 3 is a perspective diagram of an embodiment of packaging, and

Figure 4 is a perspective view of a transducer.

### BEST MODES FOR CARRYING OUT THE INVENTION

**[0009]** Referring to Figure 1 of the drawings, there is shown a panel-form loudspeaker (81) of the kind described and claimed in our co-pending International publication No. WO97/09842 of even date herewith comprising a rectangular frame (1) carrying a resilient suspension (3) round its inner periphery which supports a distributed mode sound radiating panel (2). A transducer (9) e.g. as described in detail with reference to our co-pending International publication Nos. WO97/09859, WO97/09861, WO97/09858 of even date herewith, is mounted wholly and exclusively on or in the panel (2) at a predetermined location defined by dimensions  $x$  and  $y$ , the position of which location is calculated as described in our co-pending International publication No. WO97/09842 of even date herewith, to launch bending waves into the panel to cause the panel to resonate to radiate an acoustic output.

**[0010]** The transducer (9) is driven by a signal amplifier (10), e.g. an audio amplifier, connected to the transducer by conductors (28). Amplifier loading and power requirements can be entirely normal, similar to conventional cone type speakers, sensitivity being of the order of 86 - 88dB/watt under room loaded conditions. Amplifier load impedance is largely resistive at 6 ohms, power handling 20-80 watts. Where the panel core and/or skins are of metal, they may be made to act as a heat sink for the transducer to remove heat from the motor coil of the transducer and thus improve power handling.

**[0011]** Figures 2a and 2b are partial typical cross-sections through the loudspeaker (81) of Figure 1. Figure 2a shows that the frame (1), surround (3) and panel (2) are connected together by respective adhesive-bonded joints (20). Suitable materials for the frame include lightweight framing, e.g. picture framing of extruded metal e.g. aluminium alloy or plastics. Suitable surround materials include resilient materials such as foam rubber and foam plastics. Suitable adhesives for the joints (20) include epoxy, acrylic and cyano-acrylate etc. adhesives.

**[0012]** Figure 2b illustrates, to an enlarged scale, that the panel (2) is a rigid lightweight panel having a core (22) e.g. of a rigid plastics foam (97) e.g. cross linked polyvinylchloride or a cellular matrix (98) i.e. a honeycomb matrix of metal foil, plastics or the like, with the cells extending transversely to the plane of the panel, and enclosed by opposed skins (21) e.g. of paper, card, plastics or metal foil or sheet. Where the skins are of plastics, they may be reinforced with fibres e.g. of carbon, glass, Kevlar (RTM) or the like in a manner known per se to increase their modulus.

**[0013]** Envisaged skin layer materials and reinforcements thus include carbon, glass, Kevlar (RTM), Nomex (RTM) i.e. aramid etc. fibres in various lays and weaves, as well as paper, bonded paper laminates, melamine, and various synthetic plastics films of high modulus, such as Mylar (RTM), Kaptan (RTM), polycarbonate,

phenolic, polyester or related plastics, and fibre reinforced plastics, etc. and metal sheet or foil. Investigation of the Vectra grade of liquid crystal polymer thermoplastics shows that they may be useful for the injection moulding of ultra thin skins or shells of smaller size, say up to around 30cm diameter. This material self forms an orientated crystal structure in the direction of injection, a preferred orientation for the good propagation of treble energy from the driving point to the panel perimeter.

**[0014]** Additional such moulding for this and other thermoplastics allows for the mould tooling to carry location and registration features such as grooves or rings for the accurate location of transducer parts e.g. the motor coil, and the magnet suspension. Additional with some weaker core materials it is calculated that it would be advantageous to increase the skin thickness locally e.g. in an area or annulus up to 150% of the transducer diameter, to reinforce that area and beneficially couple vibration energy into the panel. High frequency response will be improved with the softer foam materials by this means.

**[0015]** Envisaged core layer materials include fabricated honeycombs or corrugations of aluminium alloy sheet or foil, or Kevlar (RTM), Nomex (RTM), plain or bonded papers, and various synthetic plastics films, as well as expanded or foamed plastics or pulp materials, even aerogel metals if of suitably low density. Some suitable core layer materials effectively exhibit usable self-skinning in their manufacture and/or otherwise have enough inherent stiffness for use without lamination between skin layers. A high performance cellular core material is known under the trade name 'Rohacell' which may be suitable as a radiator panel and which is without skins. In practical terms, the aim is for an overall lightness and stiffness suited to a particular purpose, specifically including optimising contributions from core and skin layers and transitions between them.

**[0016]** Several of the preferred formulations for the panel employ metal and metal alloy skins, or alternatively a carbon fibre reinforcement. Both of these, and also designs with an alloy Aerogel or metal honeycomb core, will have substantial radio frequency screening properties which should be important in several EMC applications. Conventional panel or cone type speakers have no inherent EMC screening capability.

**[0017]** In addition the preferred form of piezo and electro dynamic transducers have negligible electromagnetic radiation or stray magnet fields. Conventional speakers have a large magnetic field, up to 1 metre distant unless specific compensation counter measures are taken.

**[0018]** Where it is important to maintain the screening in an application, electrical connection can be made to the conductive parts of an appropriate DML panel or an electrically conductive foam or similar interface may be used for the edge mounting.

**[0019]** The suspension (3) may damp the edges of the panel (2) to prevent excessive edge movement of the

panel. Additionally or alternatively, further damping may be applied, e.g. as patches, bonded to the panel in selected positions to damp excessive movement to distribute resonance equally over the panel. The patches may be of bitumen-based material, as commonly used in conventional loudspeaker enclosures or may be of a resilient or rigid polymeric sheet material. Some materials, notably paper and card, and some cores may be self-damping. Where desired, the damping may be increased in the construction of the panels by employing resiliently setting, rather than rigid setting adhesives.

**[0020]** Effective said selective damping includes specific application to the panel including its sheet material of means permanently associated therewith. Edges and corners can be particularly significant for dominant and less dispersed low frequency vibration modes of panels hereof. Edge-wise fixing of damping means can usefully lead to a panel with its said sheet material fully framed, though their corners can often be relatively free, say for desired extension to lower frequency operation. Attachment can be by adhesive or self-adhesive materials. Other forms of useful damping, particularly in terms of more subtle effects and/or mid- and higher frequencies can be by way of suitable mass or masses affixed to the sheet material at predetermined effective medial localised positions of said area.

**[0021]** An acoustic panel as described above is bidirectional. The sound energy from the back is not strongly phase related to that from the front. Consequently there is the benefit of overall summation of acoustic power in the room, sound energy of uniform frequency distribution, reduced reflective and standing wave effects and with the advantage of superior reproduction of the natural space and ambience in the reproduced sound recordings.

**[0022]** While the radiation from the acoustic panel is largely non-directional, the percentage of phase related information increases off axis. For improved focus for the phantom stereo image, placement of the speakers, like pictures, at the usual standing person height, confers the benefit of a moderate off-axis placement for the normally seated listener optimising the stereo effect. Likewise the triangular left/right geometry with respect to the listener provides a further angular component. Good stereo is thus obtainable.

**[0023]** There is a further advantage for a group of listeners compared with conventional speaker reproduction. The intrinsically dispersed nature of acoustic panel sound radiation gives it a sound volume which does not obey the inverse square law for distance for an equivalent point source. Because the intensity fall-off with distance is much less than predicted by inverse square law then consequently for off-centre and poorly placed listeners the intensity field for the panel speaker promotes a superior stereo effect compared to conventional speakers. This is because the off-centre placed listener does not suffer the doubled problem due to proximity to the nearer speaker; firstly the excessive increase in

loudness from the nearer speaker, and then the corresponding decrease in loudness from the further loudspeaker.

**[0024]** There is also the advantage of a flat, lightweight panel-form speaker, visually attractive, of good sound quality and requiring only one transducer and no crossover for a full range sound from each panel diaphragm.

**[0025]** Figure 3 illustrates packaging incorporating the loudspeaker technology of Figures 1 and 2. As shown in Figure 3, the packaging is in the form of a box (111) having a hinged lid (139), the box, or at least part of it being made from a composite comprising a core of foamed plastics sandwiched between sheets of craft board to form a panel as shown in Figure 2, such that the box comprises a rigid, lightweight distributed mode acoustic radiator as described with reference to Figures 1 and 2.

**[0026]** In the present case, the rear panel (140) of the box is used to form a distributed mode radiator loudspeaker (81), although any one of the panels making up the sides of the box would be suitable if suitably constructed. An alternative placement for the transducer (9) is shown in dotted lines.

**[0027]** A piezo transducer (9) as shown in Figure 4 is attached to the inner face of the rear panel (140) of the box and is driven by a sound generator/amplifier/battery unit (112) also mounted on the rear panel. The unit (112) is controlled by a switch formed integrally with a hinge (53) by which the lid (139) is secured to the box, whereby the sound generator is activated when the lid is lifted.

**[0028]** In this arrangement the edge termination of the panel (2) is formed by the corners of the box so that no additional frame (1) or suspension (3) of the kind shown in Figures 1 and 2 is required.

**[0029]** It will be appreciated that the packaging need not be of the shape shown in the drawing, and could, for example, be shaped according to the requirements of the contents. Thus the packaging might be shaped to enclose a compact disc or the like and may be arranged to provide an audio preview of the contents of the compact disc or to provide other information relating thereto. As another example, the packaging may form a musical box. As a further example the packaging may be arranged to give audio instructions concerning the contents.

**[0030]** Figure 4 shows a transducer (9) for a distributed mode panel (2) in the form of a crystalline disc-like piezo bender (27) mounted on a disc (118), e.g. of brass, which is bonded to a face of the panel (2), e.g. by an adhesive bond (20). In operation an acoustic signal applied to the transducer (9) via leads (28) will cause the piezo disc (27) to bend and thus locally resiliently deform the panel (2) to launch bending waves into the panel.

**Claims**

1. Packaging (111) comprising a sound generator, characterised by a board component (2) forming a part of the packaging and acting as a member (2) having capability to sustain and propagate input vibrational energy by bending waves in at least one operative area extending transversely of thickness to have resonant mode vibration components distributed over said at least one area and have predetermined preferential locations or sites within said area for transducer means and having a transducer (9) mounted wholly and exclusively on said member at one of said locations or sites to vibrate the member to cause it to resonate forming an acoustic radiator which provides an acoustic output when resonating. 5
2. Packaging according to claim 1, characterised in that the member (2) comprises a cellular core (22) sandwiched between skin layers (21). 10
3. Packaging according to claim 2, characterised in that the member (2) comprises a core (22) of foamed plastics (97) sandwiched between sheets of craft board (21). 15
4. Packaging according to any one of claims 1 to 3, characterised in that the transducer (19) is a piezoelectric bender. 20
5. Packaging according to claim 4, characterised in that the bender (9) is crystalline. 25
6. Packaging according to any preceding claims, characterised in that the member (2) forms one side of a box (111). 30
7. Packaging according to claim 6, characterised in that the box (111) has a lid (139), and by means (53) associated with the lid for triggering actuation of the transducer (9) on movement of the lid relative to the box. 35
8. Packaging according to claim 7, characterised by a signal generator, an amplifier and an electric battery (112) to drive the transducer. 40

**Patentansprüche**

1. Verpackung (111) mit einem Tongenerator, gekennzeichnet durch eine Plattenkomponente (2), die einen Teil der Verpackung bildet und als ein Bauteil (2) mit der Fähigkeit dient, eingespeiste Schwingungsenergie aufrechtzuerhalten und durch Biege- wellen in zumindest einer wirksamen Fläche fortzupflanzen, die quer zur Dicke verläuft, um Resonanz- 45

moden-Schwingungskomponenten über die zumindest eine Fläche zu verteilen mit vorbestimmten bevorzugten Orten oder Stellen innerhalb der Fläche für Wandlereinrichtungen, und mit einem Wandler (9), der ganz und ausschließlich auf dem Bauteil an einem der Orte oder Stellen angebracht ist, um das Bauteil in Schwingung zu versetzen, um es in Resonanz treten zu lassen, wobei ein akustischer Strahler geschaffen wird, der ein akustisches Ausgangssignal liefert, wenn er in Resonanz schwingt.

2. Verpackung nach Anspruch 1, dadurch gekennzeichnet, daß das Bauteil (2) einen zwischen Hautschichten (21) sandwichartig aufgenommenen zellularen Kern (22) aufweist. 15
3. Verpackung nach Anspruch 2, dadurch gekennzeichnet, daß das Bauteil (2) einen Kern (22) aus geschäumtem Kunststoff (97) aufweist, der zwischen Schichten aus Kraftpappe (21) sandwichartig aufgenommen ist. 20
4. Verpackung nach einem der Ansprüche 1 bis 3, dadurch gekennzeichnet, daß der Wandler (9) eine piezoelektrische Biegevorrichtung ist. 25
5. Verpackung nach Anspruch 4, dadurch gekennzeichnet, daß die Biegevorrichtung (9) kristallin ist. 30
6. Verpackung nach einem der vorhergehenden Ansprüche, dadurch gekennzeichnet, daß das Bauteil (2) eine Seite eines Kastens (111) bildet. 35
7. Verpackung nach Anspruch 6, dadurch gekennzeichnet, daß der Kasten (111) einen Deckel (139) aufweist, und durch eine mit dem Deckel verbundene Einrichtung (53), um auf eine Bewegung des Deckels in bezug auf den Kasten hin eine Betätigung des Wandlers (9) auszulösen. 40
8. Verpackung nach Anspruch 7, gekennzeichnet durch einen Signalgenerator, einen Verstärker und eine elektrische Batterie (112), um den Wandler anzutreiben. 45

**Revendications**

1. Emballage (11) comprenant un générateur de son, caractérisé par un composant (2) consistant en un panneau, qui fait partie de l'emballage et qui agit à la manière d'un élément (2) ayant la possibilité d'entretenir et de faire propager de l'énergie vibratoire d'entrée, par des ondes de flexion, dans au moins une zone active s'étendant transversalement à l'épaisseur, pour avoir des composantes de vibration de mode résonnant réparties sur la zone précitée, et pour avoir des emplacements ou des sites 50

préférentiels prédéterminés à l'intérieur de cette zone pour des moyens à transducteur, et ayant un transducteur (9) monté complètement et exclusivement sur l'élément, à l'un des emplacements ou des sites, pour faire vibrer l'élément de façon qu'il résonne en formant un radiateur acoustique qui produit une émission acoustique lorsqu'il résonne.

5

2. Emballage selon la revendication 1, caractérisé en ce que l'élément (2) comprend une âme cellulaire (22) intercalée entre des couches de peau (21). 10
3. Emballage selon la revendication 2, caractérisé en ce que l'élément (2) comprend une âme (22) en matière plastique (97) sous forme de mousse, intercalée entre des feuilles de papier kraft (21). 15
4. Emballage selon l'une quelconque des revendications 1 à 3, caractérisé en ce que le transducteur (9) est un vibreur piézoélectrique à mouvement de flexion. 20
5. Emballage selon la revendication 4, caractérisé en ce que le vibreur (9) à mouvement de flexion est cristallin. 25
6. Emballage selon l'une quelconque des revendications précédentes, caractérisé en ce que l'élément (2) forme un côté d'une boîte (111). 30
7. Emballage selon la revendication 6, caractérisé en ce que la boîte (111) a un couvercle (139), et par des moyens (53) associés au couvercle pour déclencher l'actionnement du transducteur (9) sous l'effet du mouvement du couvercle par rapport à la boîte. 35
8. Emballage selon la revendication 7, caractérisé par un générateur de signal, un amplificateur et une pile électrique (112) pour exciter le transducteur. 40

45

50

55

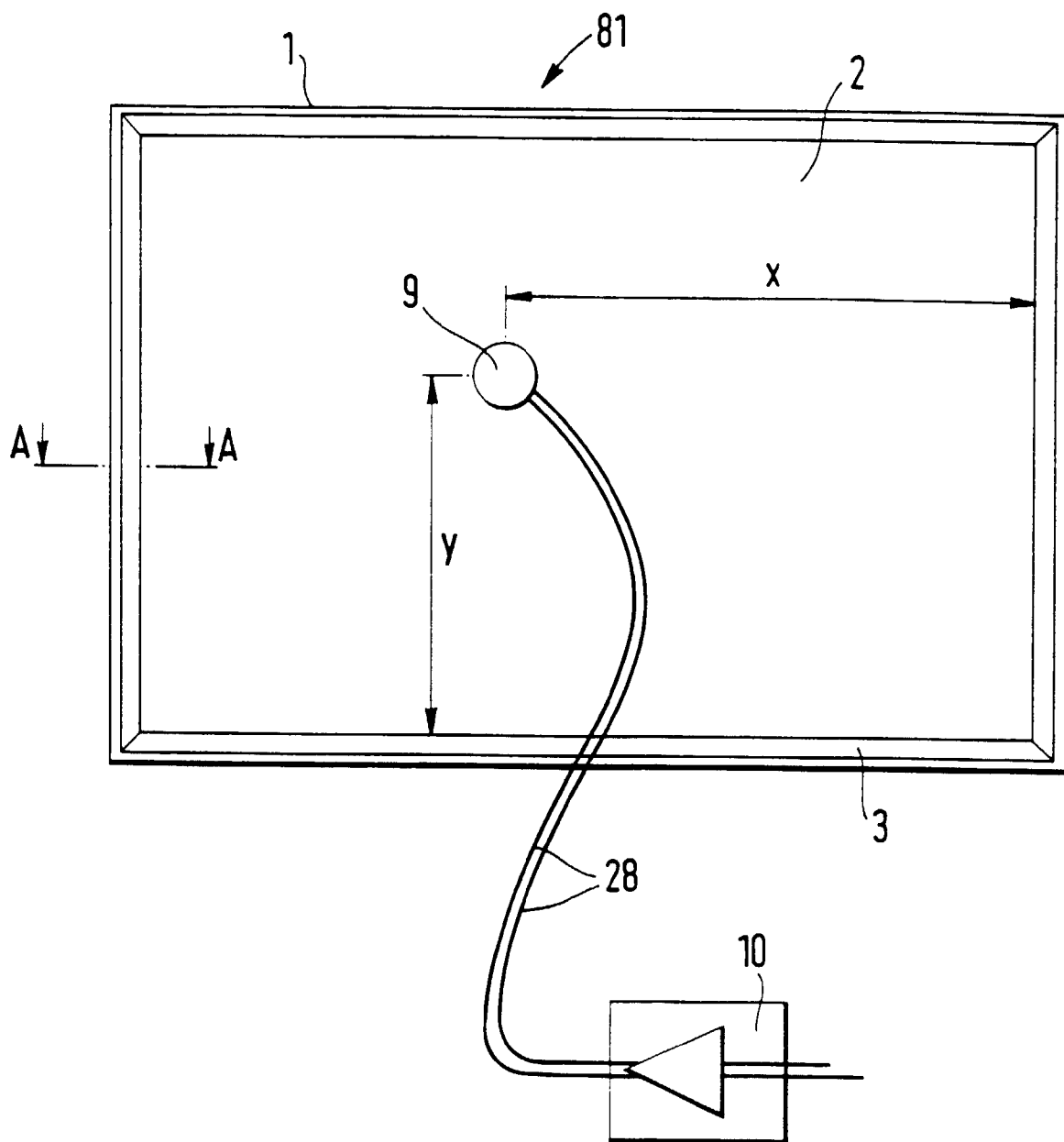

Fig. 1

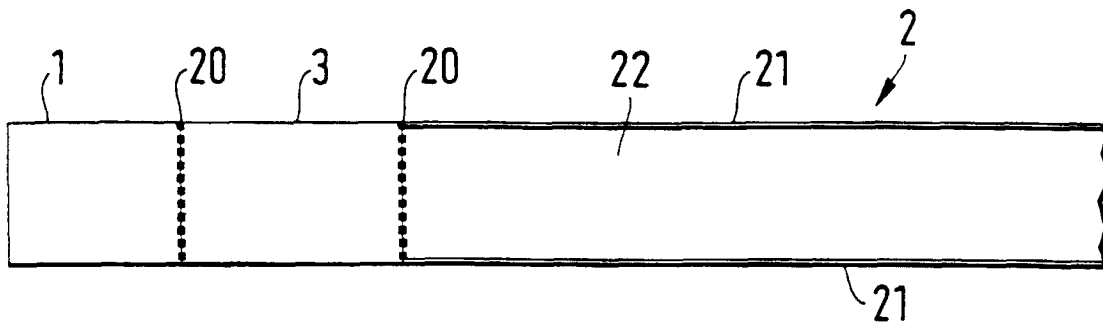

Fig. 2a

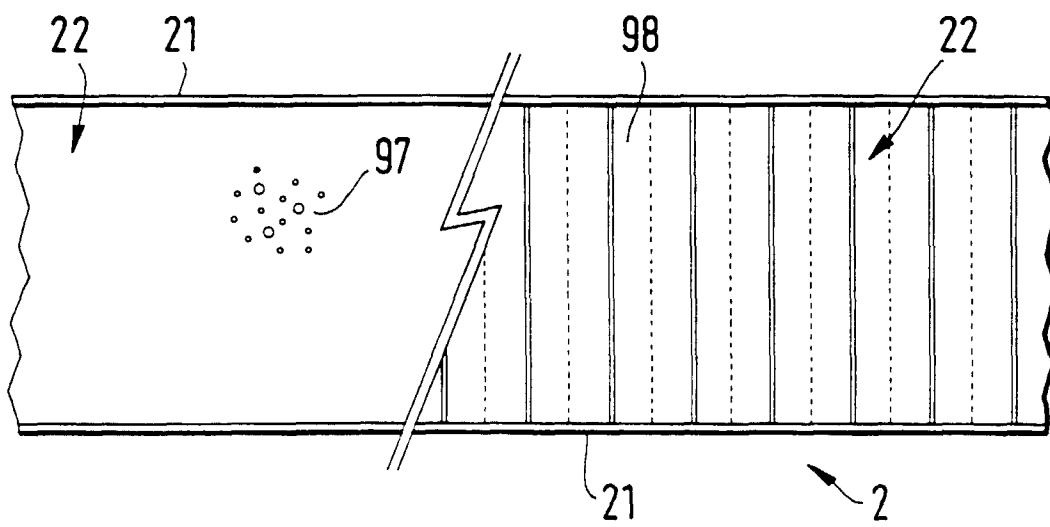
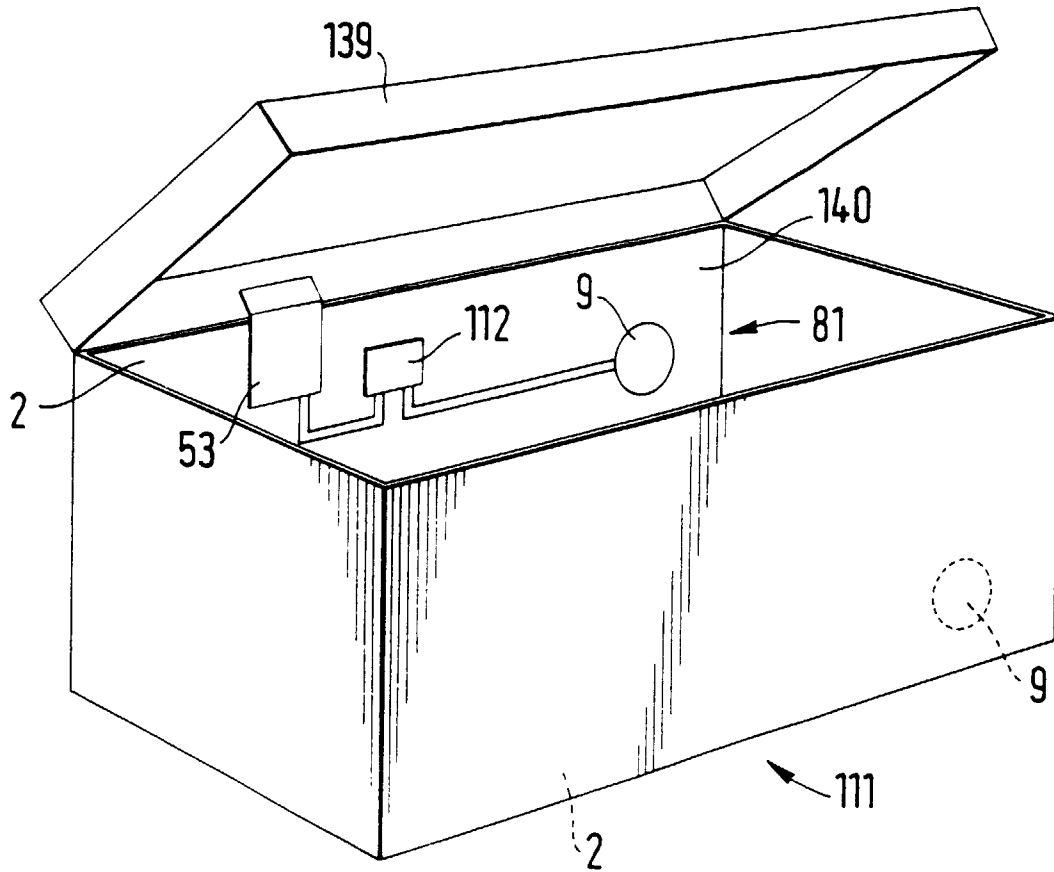
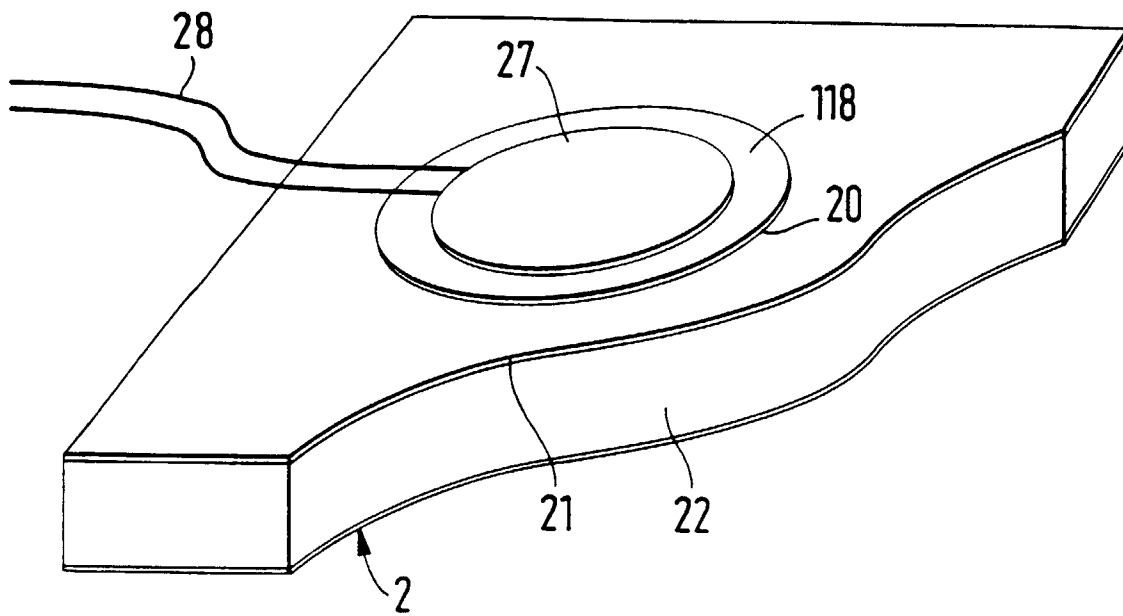

Fig. 2b



*Fig. 3*



*Fig.4*