



(51) International Patent Classification:

A47B 46/00 (2006.01) E05D 3/04 (2006.01)
A47B 47/03 (2006.01) E05D 7/00 (2006.01)
A47B 96/06 (2006.01) E06B 7/00 (2006.01)
A47B 96/16 (2006.01)

(21) International Application Number:

PCT/US2017/033765

(22) International Filing Date:

22 May 2017 (22.05.2017)

(25) Filing Language:

English

(26) Publication Language:

English

(30) Priority Data:

15/161,330 23 May 2016 (23.05.2016) US

(71) Applicant: HINGENUITY INTERNATIONAL, LLC [US/US]; c/o Livingston Loeffler, P.A., 963 Trail Terrace Drive, Naples, Florida 34103 (US).

(72) Inventors: TASSIN, Timothy Wayne; c/o Livingston Loeffler, 963 Trail Terrace Drive, Naples, Florida 34103 (US). TASSIN, Christian; c/o Livingston Loeffler, P.A., 963 Trail Terrace Drive, Naples, Florida 34103 (US).

(74) Agent: LIVINGSTON, Edward M. et al.; Livingston Loeffler, P.A., 963 Trail Terrace Drive, Naples, Florida 34103 (US).

(81) Designated States (unless otherwise indicated, for every kind of national protection available): AE, AG, AL, AM, AO, AT, AU, AZ, BA, BB, BG, BH, BN, BR, BW, BY, BZ, CA, CH, CL, CN, CO, CR, CU, CZ, DE, DJ, DK, DM, DO, DZ, EC, EE, EG, ES, FI, GB, GD, GE, GH, GM, GT, HN, HR, HU, ID, IL, IN, IR, IS, JP, KE, KG, KH, KN, KP, KR, KW, KZ, LA, LC, LK, LR, LS, LU, LY, MA, MD, ME, MG, MK, MN, MW, MX, MY, MZ, NA, NG, NI, NO, NZ, OM, PA, PE, PG, PH, PL, PT, QA, RO, RS, RU, RW, SA, SC, SD, SE, SG, SK, SL, SM, ST, SV, SY, TH, TJ, TM, TN, TR, TT, TZ, UA, UG, US, UZ, VC, VN, ZA, ZM, ZW.

(84) Designated States (unless otherwise indicated, for every kind of regional protection available): ARIPO (BW, GH, GM, KE, LR, LS, MW, MZ, NA, RW, SD, SL, ST, SZ, TZ, UG, ZM, ZW), Eurasian (AM, AZ, BY, KG, KZ, RU, TJ, TM), European (AL, AT, BE, BG, CH, CY, CZ, DE, DK, EE, ES, FI, FR, GB, GR, HR, HU, IE, IS, IT, LT, LU, LV, MC, MK, MT, NL, NO, PL, PT, RO, RS, SE, SI, SK, SM, TR), OAPI (BF, BJ, CF, CG, CI, CM, GA, GN, GQ, GW, KM, ML, MR, NE, SN, TD, TG).

(54) Title: HINGE MOUNTED CABINET

(57) Abstract: A hinge mounted cabinet (1) that can be assembled from one or more sections (22) using a plurality of internal support channels (15) that are locked together using splines (23) and caps (31, 32) to form a main body (2) of the cabinet. An exterior support channel (39) allows hinge hanging brackets (40) to be easily positioned to accommodate various sized door and hinge configurations.

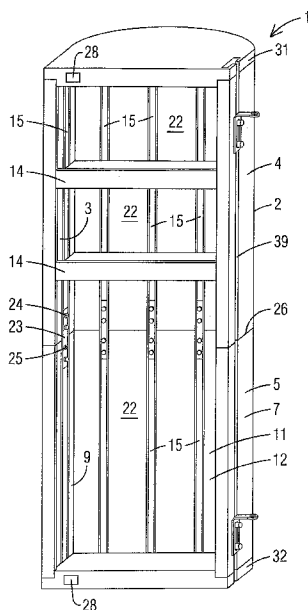

FIG. 1



WO 2017/205253 A1

Published:

— *with international search report (Art. 21(3))*

HINGE MOUNTED CABINET

FIELD OF THE INVENTION

This invention relates to storage devices and more particularly to a cabinet that is mountable to one or more existing hinges and hinge pins of a door.

5

BACKGROUND OF THE INVENTION

Additional storage has always been a desirable commodity in homes and other structures where space is at a premium. One overlooked area in the past has been the space located behind doors. Storage devices have been developed in the past that hang over the upper edge of doors on hooks and/or attach directly to a rear surface of a door with screws, bolts and/or adhesives. However, these devices may damage the door's finish, damage the structural integrity of the door and/or make it difficult for the door to close by interfering with the door jam.

An additional problem with conventional door mounted cabinets is the size and weight of the devices, which make shipping and transportation expensive and add unnecessary weight to the door when installed thereon.

Therefore, a need exists for a hinge mounted cabinet that that is mountable to one or more existing hinges and hinge pins of a door wherein the weight of the cabinet is supported by the existing hinges, not the door, and a hinge mounted cabinet that is preferably light, modular and easy to install on any configuration of hinges.

20

SUMMARY OF THE INVENTION

The primary object of the present invention is to provide a cabinet that that is mountable to one or more existing hinges and hinge pins of a door wherein the weight of the cabinet is supported by the existing door hinges and not the door and a hinge

mounted cabinet that is preferably light, modular and easy to install on any configuration of hinges.

The present invention fulfills the above and other objects by providing a cabinet that can be assembled from one or more sections using a plurality of internal support channels that are locked together using splines and caps to form a main body of the cabinet. An exterior support channel allows hinge hanging brackets to be easily positioned to accommodate various sized doors and hinge configurations. The use of internal support channels and external support channels eliminates the need for apertures in the main body of the cabinet. Therefore, the cabinet and sections thereof are ideally manufactured using plastic extrusion.

The above and other objects, features and advantages of the present invention should become even more readily apparent to those skilled in the art upon a reading of the following detailed description in conjunction with the drawings wherein there is shown and described illustrative embodiments of the invention.

BRIEF DESCRIPTION OF THE DRAWINGS

In the following detailed description, reference will be made to the attached drawings in which:

FIG. 1 is a perspective interior view of a cabinet from the interior side of the cabinet;

FIG. 2 is a perspective interior view of a cabinet from the exterior side of the cabinet;

FIG. 3 is a sectional view along line 3-3 of **FIG. 2**;

FIG. 4 is a magnified view of line 4-4 of **FIG. 2**;

FIG. 5 is a perspective top view of right-slotted cap of the present invention;

FIG. 6 is a perspective top view of left-slotted cap of the present invention;

FIG. 7 is a perspective side view of a hinge hanging bracket of the present invention;

20. threaded portion of support post
21. nut
22. section of the main body
23. spline
- 5 24. bolt
25. threaded aperture
26. joint line trim
27. handle
28. magnet
- 10 29. right slotted cap
30. left slotted cap
31. top of main body
32. bottom of main body
33. front edge of cap
- 15 34. side interior edge of cap
35. side exterior edge of cap
36. rear edge of cap
37. top surface of cap
38. bottom surface of cap
- 20 39. exterior support channel
40. hinge hanging bracket
41. door hinge
42. insert
43. rectangular-shaped plate
- 25 44. top of rectangular-shaped plate
45. bottom of rectangular-shaped plate
46. side of rectangular-shaped plate
47. aperture on rectangular-shaped plate
48. arm
- 30 49. proximal end of arm
50. distal end of arm
51. ring

- 52. ring aperture
- 53. diameter of ring
- 54. width of arm
- 55. internal mounting plate
- 5 56. aperture on internal mounting plate
- 57. nut
- 58. bolt
- 59. hinge pin
- 60. retaining channels
- 10 61. side edge of rear panel
- 62. side edge of insert
- 63. clip

With reference to **FIGS. 1-5**, the cabinet **1** of the present invention comprises a
15 main body **2** having an interior surface **3** and an exterior surface **4**, an interior side panel
5 having an interior surface **6** and an exterior surface **7**, an exterior side panel **8** having
an interior surface **9** and an exterior surface **10** and a rear panel **11** having an interior
surface **12** and an exterior surface **13**. The main body **2** houses an open storage area for
placing one or more shelves **14** that extend across the cabinet **1** from the interior side
20 panel **5** to the exterior side panel **8**. The rear panel **11** may be flat or curved as illustrated
herein.

Interior support channels **15** are preferably located on the interior surface **3** of the
main body **2**. The interior support channels **15** preferably run vertically along the interior
surfaces **6**, **9** and **12** of the interior side panel **5**, the exterior side panel **8** and the rear
25 panel **11**. The interior support channels **15** comprise a recessed groove **16** partially
covered by two flanges **17** that extend inward a predetermined distance over the recessed
groove **16** to form a slot **18** that allows access to the recessed groove **16** through which
various attachment means may be inserted and secured. Support posts **19** (as illustrated

in FIG. 3) comprising a threaded portion 20 and nut 21 may be inserted into the interior support channel 15 and locked into desired positions to adjust heights of one or more shelves 14 within the main body 2. The support posts 19 are locked into position by rotating the threaded portion 20 of the support post 19 in relation to the nut 21 located within a recessed groove 16 of the interior support channel 15, thereby creating a pressure fit between the support post 19, nut 21 and the flanges 17 of the interior support channel 15.

The main body 2 of the cabinet 1 may be a modular unit wherein the main body 2 comprises one or more sections 22 that may be attached to each other to make a taller cabinet 1. The sections 22 are preferably secured together using one or more splines 23 that are inserted into the interior support channels 15 located on the interior surface 3 of the main body 2 and, thus, the sections 22 thereof. The splines 23 are secured using threaded bolts 24 that engage threaded apertures 25 located on the splines 23, as illustrated in FIG 4. A joint line 26 located between the sections 22 may be covered using a piece of trim 27 that attaches to the exterior surface 4 of the main body 2.

A handle 27, which may be recessed, is preferably located on the exterior surface 10 of the exterior side panel 8 to allow a user to open and close the cabinet 1. A magnet 28 located on the cabinet 1 keeps the cabinet 1 in a closed position against the door by engaging a corresponding magnet 28 that may be installed on the door.

As illustrated in FIGS. 5 and 6, a perspective top view of a right slotted cap 29 and a perspective top view of a left slotted cap 30, respectively, are illustrated. The caps 29, 30 attach to a top 31 and bottom 32 of the main body 2. Each cap 29, 30 comprises a front edge 33, side interior edge 34, side exterior edge 35, rear edge 36, top surface 37 and bottom surface 38. Exterior support channels 39 are located on the side interior

edges **34** of both the right slotted cap **29** and the left slotted cap **30** in locations that align with the exterior support channel **39** located on the interior side panel **3** of the main body **2**, as illustrated in **FIGS. 1** and **3**. This configuration allows the cabinet **1** to be installed on any door regardless of whether the door opens to the right or the left simply by flipping the cabinet **1** upside down so the interior side panel **3** faces the side of the door where hinges are installed so the exterior support channel **39** cannot be seen from the door knob side of the door.

With reference to **FIGS. 7** and **8**, a perspective side view of a hinge hanging bracket **40** of the present invention and a perspective top view of a hinge hanging bracket **40** of the present invention, respectively, are illustrated. The hinge hanging bracket **40** comprises a substantially rectangular-shaped plate **43** having a top **44**, bottom **45**, and sides **46**. At least one aperture **47** is located on the substantially rectangular-shaped plate **43**. An arm **48** having a proximal end **49** and distal end **50** extends from the top of the substantially rectangular-shaped plate **43**. A ring **51** and aperture **52** are located on the distal end **50** of the arm **48**. An additional feature of the hinge hanging bracket **40**, is that the arm **48** has a width **53** that is less than a diameter **54** of ring **51** and the distal end **50** of the arm **48**. The width **53** of the arm **48** provides clearance from obstructions, such as hinge plates, molding and so forth, so the hinge hanging bracket **40** can be swung back and forth a full 180 degrees in relation to a closed door and a parallel wall. The hinge hanging bracket **40** may also be used with a wall hanging bracket instead of a door hinge. The wall hanging bracket is an L-shaped bracket that attaches to a flat surface, such as a wall or a door, using screws and/or bolts. A stud or cylindrical projection extends from one end of the L-shaped bracket to engage the ring **51** and the distal end **50** of the arm **48**.

With reference to **FIGS. 9** and **10**, a perspective side view of a partially exploded hinge hanging bracket **40** being installed on a cabinet **1** of the present invention and a perspective side view of a hinge hanging bracket **40** installed on a cabinet **1** and hinge **58**, respectively, are illustrated. Exterior support channels **39** are located on the side interior edges **34** of both the right slotted cap **29** and the left slotted cap **30**, as illustrated in **FIGS. 4** and **5**, in locations that align with the exterior support channel **39** located on the interior side panel **3** of the main body **2**, as illustrated in **FIGS. 1** and **3**. The exterior support channels **39** comprise a recessed groove **16** partially covered by two flanges **17** that extend inward a predetermined distance over the recessed groove **16** to form a slot **18** that allows access to the recessed groove **16**. One or more hinge hanging brackets **40** may be secured to the interior side panel **3** by inserting an internal mounting plate **55** comprising at least one aperture **56** into the exterior support channel **39**. The internal mounting plate **55** is secured to the hinge hanging bracket **40** by one or more nuts **57** and bolts **58** that allow the internal mounting plate **55** and hinge hanging bracket **40** to be tightened together, thereby sandwiching the flanges **17** of the exterior support channel **39** between the internal mounting plate **55** and hinge hanging bracket **40**.

The hinge hanging bracket **40** may be installed on a conventional door hinge **41** by removing a hinge pin **59** from a the door hinge **41** and then placing the hinge pin **59** through the aperture **52** located on the distal end **50** of the arm **48** and back into the door hinge **41**. The hinge hanging bracket **40** may then be rotated on the door hinge **41** and hinge pin **59**, thereby allowing the cabinet **1** to be opened and closed.

With reference to **FIGS. 11** and **12**, a rear perspective view of a hinge mounted cabinet **1** of the present invention having an insert **42** secured to the rear panel **11** and a sectional view along line **12-12** of **FIG. 11**, respectively, are illustrated. The insert **42** is

preferably a rectangular-shaped piece of material, such as mirror, dry erase board, chalk board, cork board, peg board and so forth, that is attached to the rear panel 11 via an attachment means, such as adhesive, clips and so forth. As illustrated in FIG. 12, the insert 42 is attached to the cabinet 1 using retaining channels 60 located on side edges 61 of the rear panel 11. The retaining channels 60 are formed by clips 63 that extend outward from the rear panel 11 a predetermined distance and hold side edges 62 of the insert 42 against the rear panel 11, thereby sandwiching the side edges 62 of the insert 42 between the clips 63 and the rear panel 11. The retaining channels 60 and clips 63 may also be located on the caps 29, 30 to secure upper and lower edges of the insert 42.

It is to be understood that while a preferred embodiment of the invention is illustrated, it is not to be limited to the specific form or arrangement of parts herein described and shown. It will be apparent to those skilled in the art that various changes may be made without departing from the scope of the invention and the invention is not to be considered limited to what is shown and described in the specification and drawings.

CLAIMS

Having thus described my invention, I claim:

1. A cabinet that is mountable to hinges having hinge pins used to hang a door
5 hung in a door jam so that said cabinet can be pivoted upon the hinge pins independently
of the door, said cabinet comprising:

a main body having an interior side panel having an interior surface and an
exterior surface, an exterior side panel having an interior surface and an exterior surface
and a rear panel having an interior surface and an exterior surface;

10 said main body housing an open storage area for placing one or more shelves that
extend across the cabinet from the interior side panel to the exterior side panel;

a first cap located on a top end of the main body;

said first cap having a front edge, interior side edge, exterior side edge, rear edge,
top surface and bottom surface;

15 a second cap located on a bottom end of the main body;

said first cap having a front edge, side interior edge, side exterior edge, rear edge,
top surface and bottom surface;

at least one exterior support channel located on the exterior surface of the interior
side panel; and

20 at least one hinge hanging bracket attached to the at least one exterior support
channel.

2. The cabinet of claim 1 further wherein:

said main body comprises at least two sections secured together via at least one an attachment means.

3. The cabinet of claim **1** further comprising:

5 at least one interior support channel located on an interior surface of the main body.

4. The cabinet of claim **2** further comprising:

at least one interior support channel located on an interior surface of the main
10 body; and

said at least two sections of the main body are attached together via at least one spline located within the at least one interior support channel.

5. The cabinet of claim **1** further comprising:

15 an exterior support channel located on the interior side edge of the first cap; and
an exterior support channel located on the interior side edge of the second cap.

6. The cabinet of claim **1** wherein:

said at least one exterior support channel comprises a recessed groove partially
20 covered by two flanges that extend inward a predetermined distance over the recessed
groove to form a slot that allows access to the recessed groove.

7. The cabinet of claim 1 wherein:

said at least one interior support channel comprises a recessed groove partially covered by two flanges that extend inward a predetermined distance over the recessed groove to form a slot that allows access to the recessed groove.

5

8. The cabinet of claim 3 wherein:

said at least one interior support channel comprises a recessed groove partially covered by two flanges that extend inward a predetermined distance over the recessed groove to form a slot that allows access to the recessed groove.

10

9. The cabinet of claim 1 wherein:

said exterior surface of the rear panel of the main body is curved.

10. The cabinet of claim 1 wherein:

15

said exterior surface of the rear panel of the main body is substantially flat.

11. The cabinet of claim 1 wherein:

said exterior surface of the rear panel of the main body further comprises an attachable insert.

20

12. A cabinet that is mountable to hinges having hinge pins used to hang a door hung in a door jam so that said cabinet can be pivoted upon the hinge pins independently of the door, said cabinet comprising:

a main body having an interior side panel having an interior surface and an exterior surface, an exterior side panel having an interior surface and an exterior surface and a rear panel having an interior surface and an exterior surface;

said main body housing an open storage area for placing one or more shelves that
5 extend across the cabinet from the interior side panel to the exterior side panel;

a first cap located on a top end of the main body;

said first cap having a front edge, interior side edge, exterior side edge, rear edge,
top surface and bottom surface;

a second cap located on a bottom end of the main body;

10 said first cap having a front edge, side interior edge, side exterior edge, rear edge,
top surface and bottom surface;

at least one exterior support channel located on the exterior surface of the interior
side panel;

at least one hinge hanging bracket attached to the at least one exterior support
15 channel; and

said main body comprises at least two sections secured together via at least one an
attachment means.

13. The cabinet of claim **12** further comprising:

20 at least one interior support channel located on an interior surface of the main
body; and

said at least two sections of the main body are attached together via at least one
spline located within the at least one interior support channel.

14. The cabinet of claim **12** further comprising:

an exterior support channel located on the interior side edge of the first cap; and

an exterior support channel located on the interior side edge of the second cap.

5 **15.** The cabinet of claim **12** wherein:

said at least one exterior support channel comprises a recessed groove partially covered by two flanges that inward a predetermined distance over the recessed groove to form a slot that allows access to the recessed groove.

10 **16.** The cabinet of claim **12** wherein:

said at least one interior support channel comprises a recessed groove partially covered by two flanges that extend inward a predetermined distance over the recessed groove to form a slot that allows access to the recessed groove.

15 **17.** The cabinet of claim **12** wherein:

said exterior surface of the rear panel of the main body is curved.

18. The cabinet of claim **12** wherein:

said exterior surface of the rear panel of the main body is substantially flat.

20

19. The cabinet of claim **12** wherein:

said exterior surface of the rear panel of the main body further comprises an attachable insert.

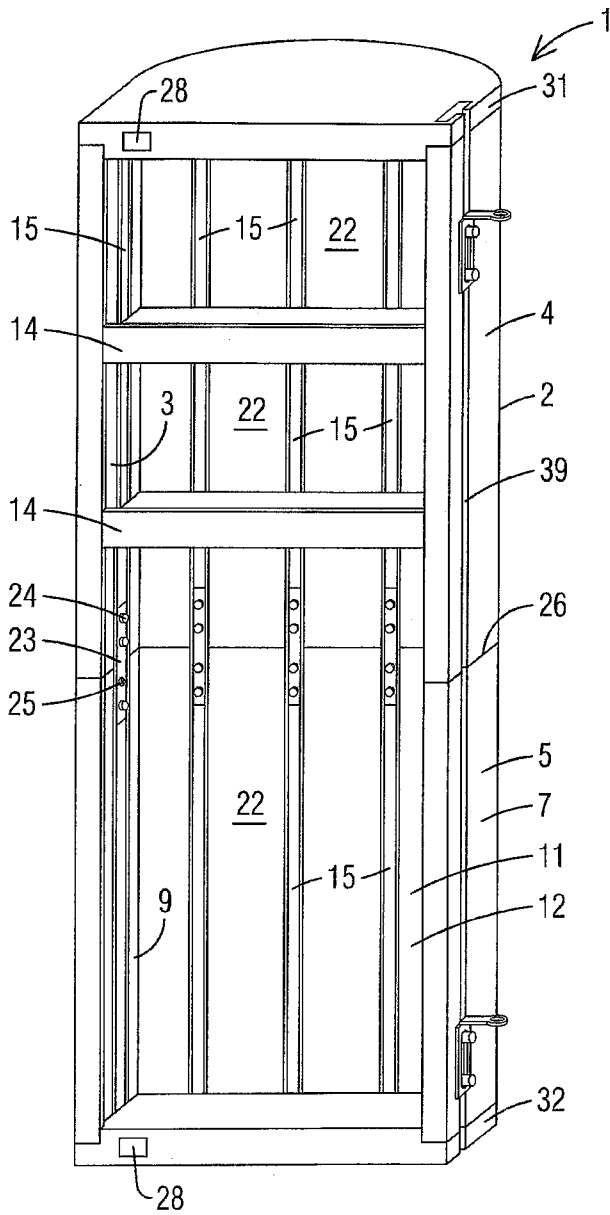

FIG. 1

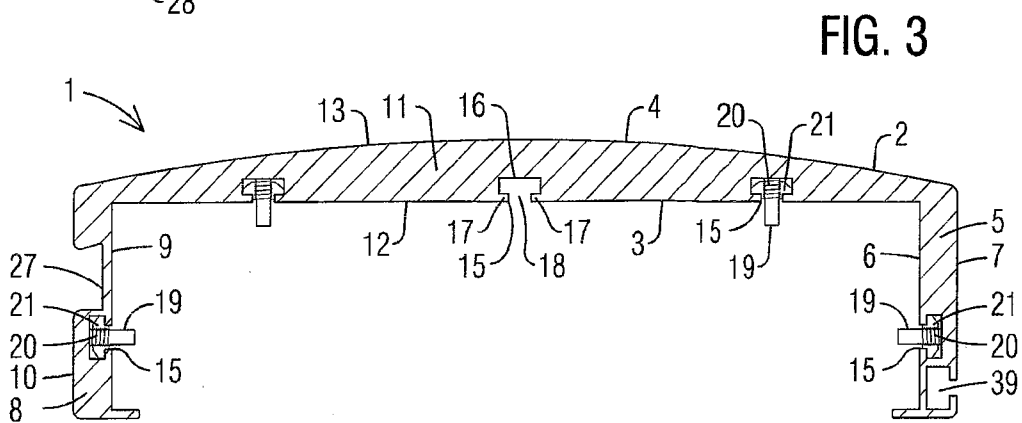

FIG. 3

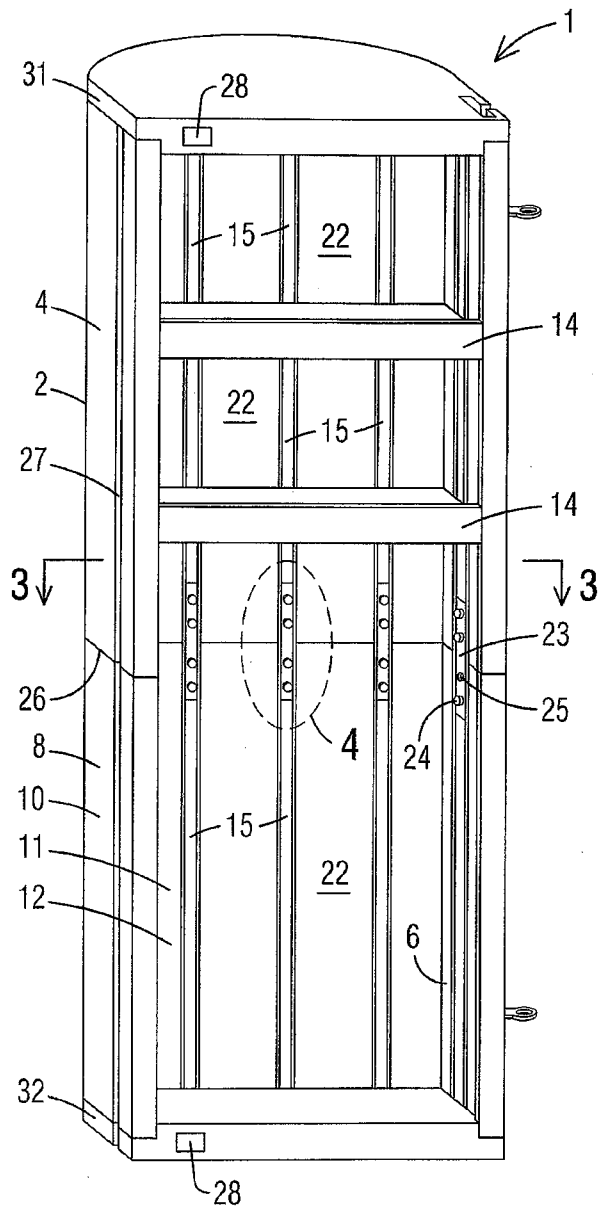

FIG. 2

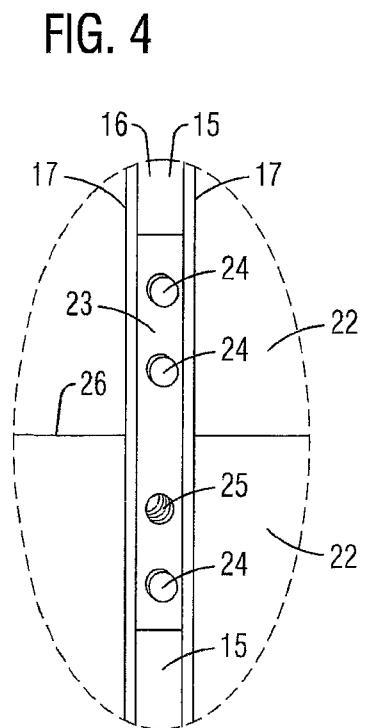

FIG. 4

FIG. 5

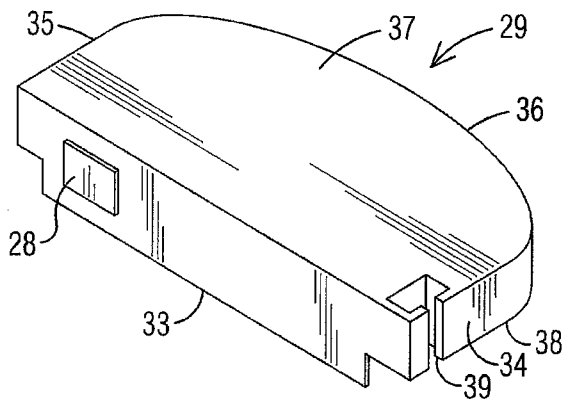

FIG. 6

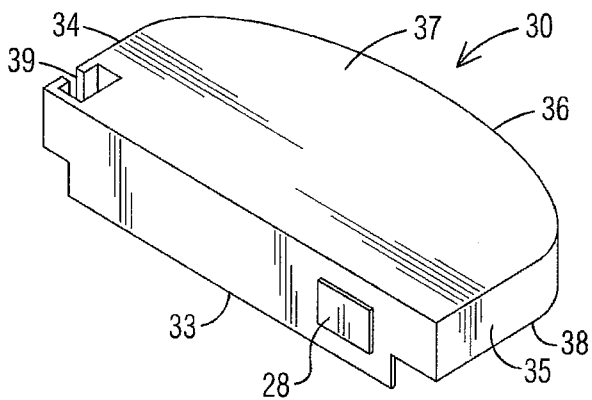

FIG. 7

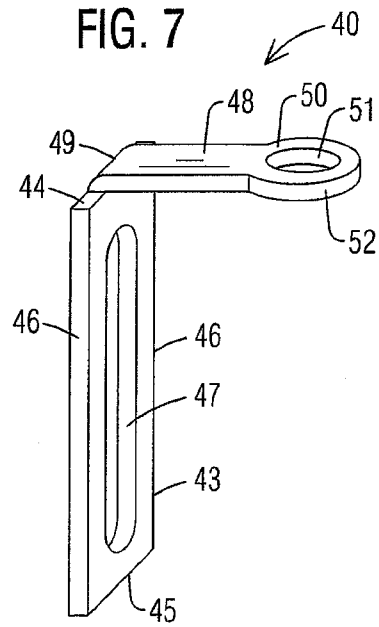

FIG. 8

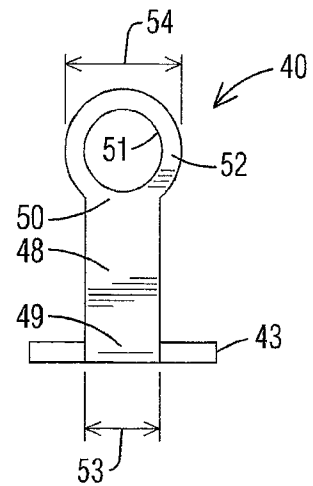

FIG. 9

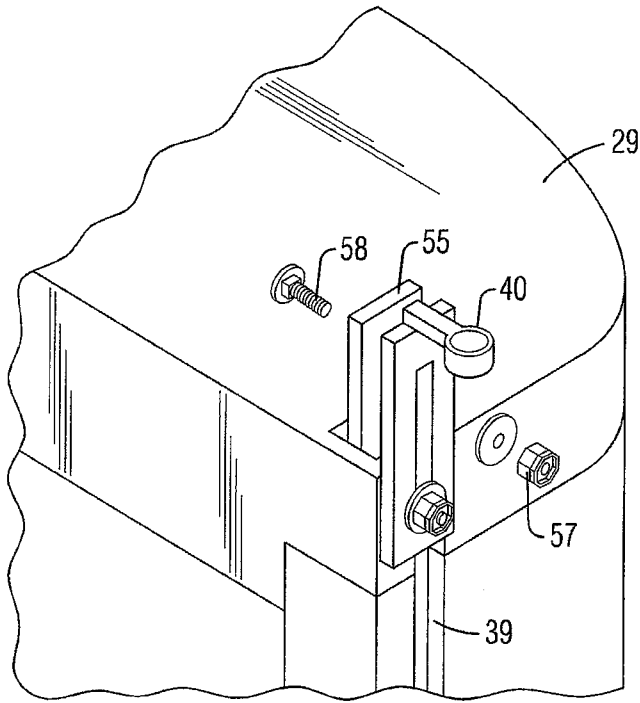

FIG. 10

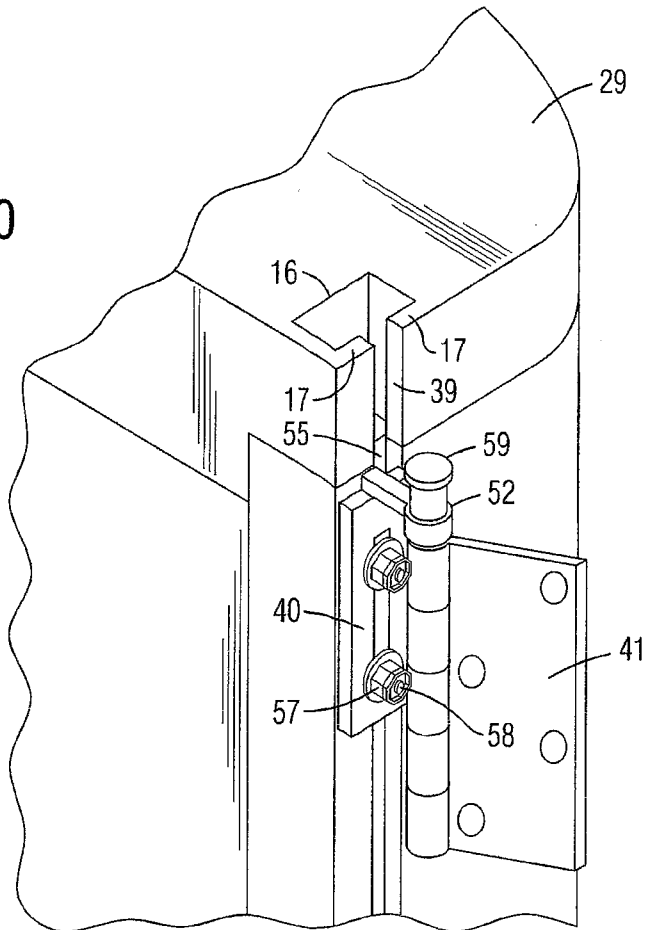

FIG. 11

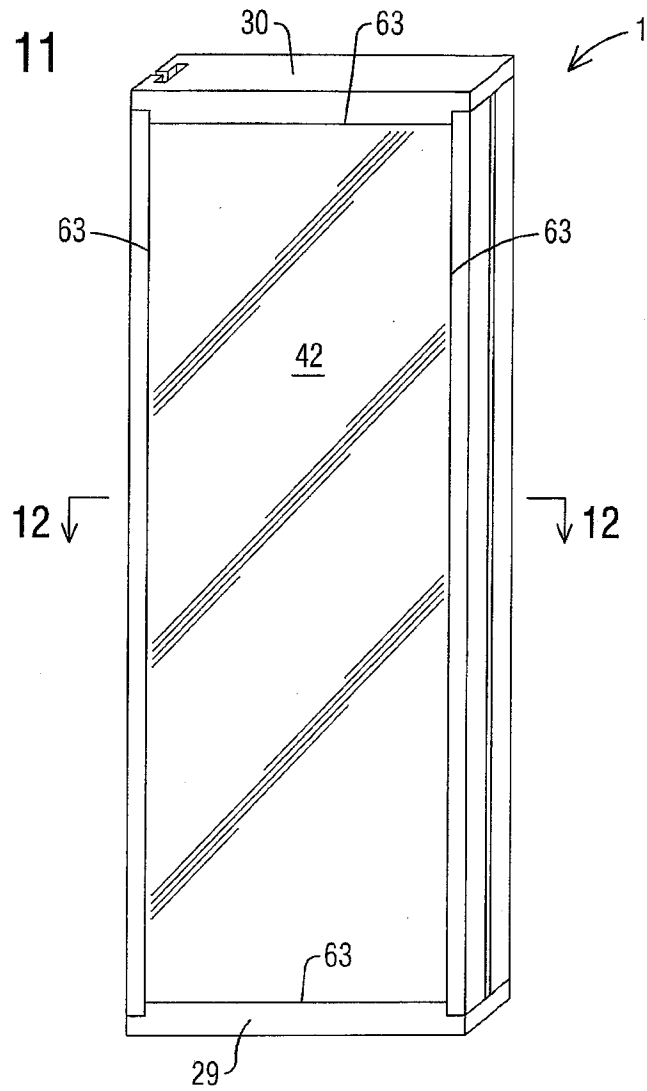
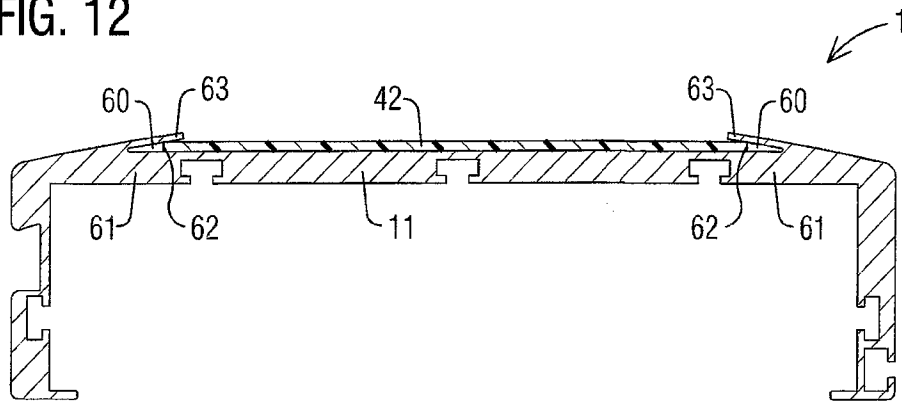

FIG. 12



INTERNATIONAL SEARCH REPORT

International application No.

PCT/US 17/33765

A. CLASSIFICATION OF SUBJECT MATTER

IPC(8) - A47B 46/00, A47B 47/03, A47B 96/06, A47B 96/16, E05D 3/04, E05D 7/00, E06B 7/00 (2017.01)
 CPC - A47B46/00, A47B47/03, A47B49/00, A47B61/00, A47B67/00, A47B83/00, A47B95/00,
 A47B96/06, A47B96/16, A47G25/02, A47B2220/0072, A47B67/005, E05C19/16, E05D3/04,
 E05D3/10, E05D7/00, E06B7/00, E06B7/34, E05D3/00, E05Y2900/132, E05Y2900/20,
 E05Y2900/208, Y10T16/5472, A47B81/00, A47B97/00, A47B2230/0025, A47B2220/0072,
 A47B67/005, E05D7/04, H02B1/44, H05K7/16

According to International Patent Classification (IPC) or to both national classification and IPC

B. FIELDS SEARCHED

Minimum documentation searched (classification system followed by classification symbols)

See Search History Document

Documentation searched other than minimum documentation to the extent that such documents are included in the fields searched

See Search History Document

Electronic data base consulted during the international search (name of data base and, where practicable, search terms used)

See Search History Document

C. DOCUMENTS CONSIDERED TO BE RELEVANT

Category*	Citation of document, with indication, where appropriate, of the relevant passages	Relevant to claim No.
A	US 8,777,339 B2 (Tassin et al.) 15 July 2014 (15.07.2014), entire document, especially Fig. 43, 44; col 21, ln 25-28; col 21, ln 28-34; col 21, ln 60-64;	1-19
A	US 2016/0073525 A1 (Maloney et al.) 10 March 2016 (10.03.2016), entire document, especially Fig. 9A, 9B, 9C; para[0069]; para[0095];	1-19
A	US 6,755,493 B1 (Krietzman et al.) 29 June 2004 (29.06.2004), entire document, especially Fig. 1, 3A, 7A; col 3, ln 54-59; col 4, ln 22-25; col 4, ln 38-44;	1-19
A	US 2005/0047097 A1 (Johnson et al.) 03 March 2005 (03.03.2005), entire document	1-19
A	US 8,944,532 B2 (Tontarelli) 03 February 2015 (03.02.2015), entire document	1-19
A	US 2014/0327350 A1 (Tassin et al.) 06 November 2014 (06.11.2014), entire document	1-19
A	US 2005/0204694 A1 (Tallman et al.) 22 September 2005 (22.09.2005), entire document	1-19
A	US 2010/0253196 A1 (Nye) 07 October 2010 (07.10.2010), entire document	1-19
X, P	US 9,609,947 B1 (Tassin et al.) 04 April 2017 (04.04.2017), entire document	1-19

 Further documents are listed in the continuation of Box C. See patent family annex.

* Special categories of cited documents:

"A" document defining the general state of the art which is not considered to be of particular relevance

"E" earlier application or patent but published on or after the international filing date

"L" document which may throw doubts on priority claim(s) or which is cited to establish the publication date of another citation or other special reason (as specified)

"O" document referring to an oral disclosure, use, exhibition or other means

"P" document published prior to the international filing date but later than the priority date claimed

"T" later document published after the international filing date or priority date and not in conflict with the application but cited to understand the principle or theory underlying the invention

"X" document of particular relevance; the claimed invention cannot be considered novel or cannot be considered to involve an inventive step when the document is taken alone

"Y" document of particular relevance; the claimed invention cannot be considered to involve an inventive step when the document is combined with one or more other such documents, such combination being obvious to a person skilled in the art

"&" document member of the same patent family

Date of the actual completion of the international search

24 July 2017

Date of mailing of the international search report

15 AUG 2017

Name and mailing address of the ISA/US

Mail Stop PCT, Attn: ISA/US, Commissioner for Patents
 P.O. Box 1450, Alexandria, Virginia 22313-1450
 Facsimile No. 571-273-8300

Authorized officer:

Lee W. Young

PCT Helpdesk: 571-272-4300
 PCT OSP: 571-272-7774