

(No Model.)

J. W. HARPER.
STACK ROOF.

No. 286,431.

Patented Oct. 9, 1883.

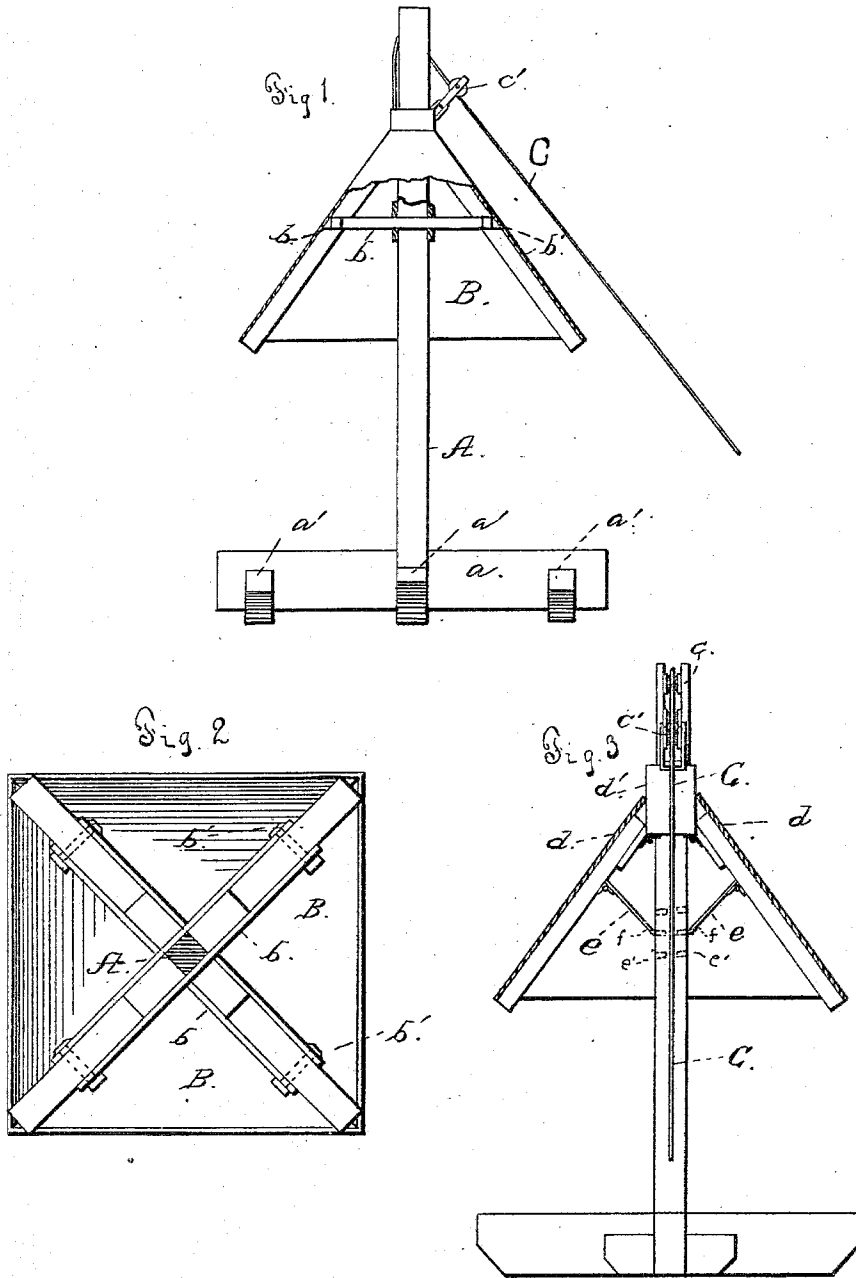

Attest
H. A. Clark
E. M. Fowler.

Inventor
John W. Harper
By R. S. W. Lacey
Attorney

UNITED STATES PATENT OFFICE.

JOHN W. HARPER, OF ASSUMPTION, ILLINOIS.

STACK-ROOF.

SPECIFICATION forming part of Letters Patent No. 286,431, dated October 9, 1883.

Application filed March 27, 1883. (No model.)

To all whom it may concern:

Be it known that I, JOHN W. HARPER, a citizen of the United States, residing at Assumption, in the county of Christian and State of Illinois, have invented certain new and useful Improvements in Stack-Roofs; and I do declare the following to be a full, clear, and exact description of the invention, such as will enable others skilled in the art to which it appertains to make and use the same, reference being had to the accompanying drawings, and to the letters and figures of reference marked thereon, which form a part of this specification.

This invention pertains to improvements in stack-roofs, and is capable of adjustment to enable the raising and lowering of the cap or cover to accommodate it to the height of the stack, and to permit of its more convenient and ready removal from place to place.

The invention consists of the combination and arrangement of parts, substantially as hereinafter fully set forth and claimed.

In the accompanying drawings, Figure 1 is a side elevation, partly in section, of my invention. Fig. 2 is an inverted view of the same, with the supporting upright taken in horizontal section: Fig. 3 is a side elevation, partly in section, of a modification of my invention.

In carrying out my invention I secure in any suitable way an upright or support, A, to an edgewise-disposed cross-piece, *a*, which is mortised and secured to runners *a'*, the latter being let into the mortises of the cross-bar *a*. This furnishes a firm support for the upright and means to permit the ready and convenient removal of the device from place to place wherever it may be needed.

B is the roof or cover proper, made, preferably, as shown, or of an approximately-conical shape, with its upper convergent end adapted to permit the passage through it of the upright or support A, and so as to allow the cover or roof to slide or move up and down thereon, the appliances to effect which will be presently described.

To the frame of the cover or roof are connected, about midway of the same, two pairs of parallel horizontal bars, *b b*, by means of

screw-bolts *b' b'*, passed through said bars and the individual pieces of the frame, a pair or two bars being secured to two pieces of said frame and arranged to pass in contact with the upright A, while the other pair of bars is secured to two other pieces of the said cover-frame and arranged to pass above or below the former pair of bars at right angles therewith and against the opposite sides of the upright A. This disposition of parts serves to brace the cover and to guide its movement upon the upright A.

C is the cover-operating rope or medium, fastened to the upper end of the cover or roof, thence passed over a pulley, *c*, hung in the upper end of the support A, thence under a pulley, *c'*, articulated to the opposite side of the same end of the roof, after which it is passed to a point where it will be convenient of manipulation, and made fast thereat in any known way. By means of the operating-rope and pulleys, the cover or roof can be readily adjusted to accommodate the height of the stack, and lowered upon the removal of the latter, to render it easier of transportation and storage when not in use.

In Fig. 3 the roof or cover is shown as composed of sections hinged, as at *d*, to a collar or sleeve, *d'*, adapted to slide on the upright A, and to which the operating-rope and the pulley *c'* are connected. The parallel bars *b* are replaced by hinged or articulated arms *e*, connected to the upright A by the insertion into apertures *e'* therein of their free ends *f*, said ends being so adapted with relation to the arms that they will enter the upright horizontally, whereby the cover is enabled to be held at any desired point of adjustment or elevation on the upright, while the cover or roof may be collapsed when it is not in use and it may be desired to economize room in storing or shipping it.

Having thus fully described my invention, I claim and desire to secure by Letters Patent—

1. The combination, with an upright or support, of the roof or cover having parallel bars embracing the upright or support, and adjusting mechanism, substantially as and for the purpose set forth.

2. The stack-roof, substantially as described

and shown, composed of the cover B, having
 an upper central opening, the parallel guide
 and brace bars embracing the central stand-
 ard, and the articulate pulley *c'*, secured to
 5 the said stack-roof, in combination with the
 standard having the guide-pulley *c*, journaled
 in its upper end, and the rope C, secured to
 the cover B on the opposite side of the upper
 opening therein from the articulate pulley *c'*,
 10 and passed up over pulley *c*, and thence down

under pulley *c'*, and extended to a point within
 reach of the operator, all arranged and oper-
 ating substantially as and for the purposes
 specified.

In testimony whereof I affix my signature in 15
 presence of two witnesses.

JOHN W. HARPER.

Witnesses:

SILAS A. SHAFER,
 RICHARD KEIRN.