

(19)



(11)

EP 3 096 015 A1

(12)

EUROPEAN PATENT APPLICATION

(43) Date of publication:
23.11.2016 Bulletin 2016/47

(51) Int Cl.:
F04C 2/14 (2006.01) F04C 15/06 (2006.01)

(21) Application number: **16169754.5**

(22) Date of filing: **16.05.2016**

(84) Designated Contracting States:
AL AT BE BG CH CY CZ DE DK EE ES FI FR GB GR HR HU IE IS IT LI LT LU LV MC MK MT NL NO PL PT RO RS SE SI SK SM TR
 Designated Extension States:
BA ME
 Designated Validation States:
MA MD

(71) Applicant: **Casappa S.p.A.**
43044 Collecchio (Parma) (IT)

(72) Inventor: **GUIDETTI, Marco**
43123 PARMA (IT)

(74) Representative: **Monelli, Alberto**
c/o BUGNION S.P.A
Largo Michele Novaro, 1/A
43121 PARMA ITALY (IT)

(30) Priority: **20.05.2015 IT UB20150848**

(54) **GEAR PUMP**

(57) A gear pump comprising:
 -a housing compartment (20) of said gears which transfer energy to a fluid crossing the pump (1);
 -a first conduit (21) which develops from the housing com-

partment (20), in a first operating mode said first conduit (21) being a delivery conduit;
 -a first stiffening rib (31) that crosses said first conduit (21) and divides the flow of fluid into at least two parts.

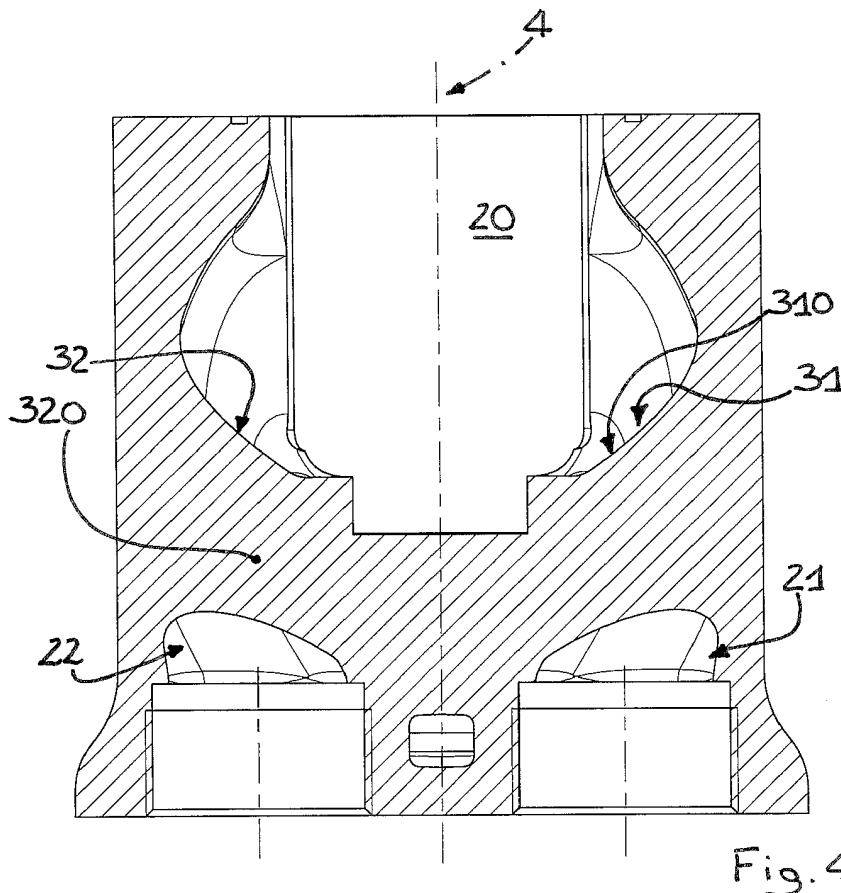

Fig. 4

EP 3 096 015 A1

Description

[0001] The present invention relates to a gear pump and a method for constructing it.

[0002] Gear pump means a pump in which the change in volume induced by the meshing of two bodies is exploited to transfer energy to a fluid passing through the pump.

[0003] There are known gear pumps comprising:

- a compartment housing the bodies which transfer energy to the fluid passing through the pump;
- an aspirating conduit which causes the fluid to be treated to enter the housing compartment;
- a delivery conduit which causes the fluid under pressure to exit the housing compartment.

[0004] One drawback of gear pumps is tied to the need to reinforce the delivery conduit, since greater pressures occur in that zone. In this way both stress and deformations are reduced to the advantage of correct functioning, but the overall dimensions of the pump are increased because of the larger thicknesses required.

[0005] In this context, the technical task at the basis of the present invention is to provide a pump which enables the overall dimensions to be reduced without penalising the correct functioning and reliability thereof.

[0006] The stated technical task and specified objects are substantially achieved by a gear pump comprising the technical features disclosed in one or more of the appended claims.

[0007] Additional features and advantages of the present invention will become more apparent from the approximate, and thus non-limiting description, of a preferred, but not exclusive embodiment of a gear pump, as illustrated in the appended drawings, in which:

- figure 1 shows a front view of a pump according to the present invention;
- figure 2 shows a view of the pump according to the section plane F-F of figure 1;
- figure 3 shows a view of the pump according to the section plane A-A of figure 1;
- figure 4 shows a view of the pump according to the section plane B-B of figure 1.

[0008] In the appended figures, the reference number 1 indicates a gear pump.

[0009] Said pump 1 comprises a compartment 20 housing said gears which transfer energy to a fluid crossing the pump 1. Advantageously, the gears comprise two cogwheels that reciprocally mesh and are positioned in the housing compartment 20. One of the gears could possibly have external teeth and the other internal teeth. More in general, the two gears could be rolling bodies that interact with each other, but do not have an involute profile (for example, a lobe pump).

[0010] The pump 1 also comprises a first conduit 21

which develops from the housing compartment 20. In a first operating mode said first conduit 21 is a delivery conduit. The first conduit 21 is thus used for discharging the fluid under pressure from the compartment 20.

[0011] The pump 1 comprises a first stiffening rib 31 that crosses the first conduit 21. The first stiffening rib 31 divides the flow of fluid into at least two parts. The two parts reconverge downstream of said first rib 31.

[0012] The first rib 31 thus serves to stiffen the delivery conduit, minimising the tensions of the material and consequently the deformations without oversizing in thickness the walls of the first conduit 21. It is thus possible to minimise the outer dimensions of the pump 1.

[0013] The first stiffening rib 31 comprises a fin 310 having an aerodynamic profile. This enables pressure drops to be minimised. An even more important advantage may be had in the case of a reversible pump, as better explained below.

[0014] The pump 1 advantageously comprises a second conduit 22 which terminates in said housing compartment 20. In the first operating mode the second conduit 22 is an aspirating conduit.

[0015] The pump 1 also comprises a second stiffening rib 32 crossing said second conduit 22.

[0016] Advantageously, the pump 1 is reversible. It can thus also function in a second operating mode in which the first conduit 21 becomes an aspirating conduit and the second conduit 22 becomes a delivery conduit. Given the reversibility of the pump 1, the presence of the rib 32 also in the second conduit 22 is thus important. In fact, the second conduit 22 can also become a delivery conduit and therefore be subject to considerable stresses due to the fluid under pressure.

[0017] Conveniently, the second stiffening rib 32 comprises a fin 320 having an aerodynamic profile.

[0018] In the first operating mode, this feature serves to minimise the pressure drops on the aspirating side in order to reduce the risk of cavitation (in the first operating mode the second rib 32 operates under aspiration and the aerodynamic profile helps for that purpose).

[0019] Advantageously, the first conduit 21 and the second conduit 22 comprise two ports 23, 24 which lie side by side on a same wall of the pump 1, turned outward. Internally of the pump the first and the second conduit 21, 22 extend side by side.

[0020] In an alternative embodiment, the two ports 23, 24 of the first and the second conduit 21, 22 could be located on two distinct walls of the pump 1; in particular, they could be lateral.

[0021] Conveniently, the first conduit 21 and the first rib 31 are in a single monolithic body.

[0022] In the preferred embodiment, in addition to the first conduit 21 and the first rib 31, the second conduit 22, the second rib 32 and at least a part of the housing compartment 20 are in a single monolithic body. The single monolithic body is advantageously made of cast iron. The single monolithic body also defines an external casing that delimits at least in part the pump 1 from the out-

side.

[0023] As exemplified in figure 4, the first conduit 21, the second conduit 22, the first and second rib 31, 32 and at least a part of the housing compartment 20 are symmetrical with respect to a median plane 4 interposed between the first and the second conduit 21, 22.

[0024] The first rib 31 comprises:

- a first and a second surface 311, 312 that are mutually opposite one another;
- a leading edge 313 and an exit edge 314 of the first rib 31 which are rounded and which reciprocally connect the first and the second surface e 311,312.

[0025] With respect to a path that goes from the housing compartment 20 towards an outside of the pump 1 along the first conduit 21, the first and the second surface 311, 312 comprise a portion 315 in which they are reciprocally divergent and a portion 316 in which they are reciprocally convergent.

[0026] One of the two parts of the flow divided by said first rib 31 skims over the first surface 311 and the other over the second surface 312.

[0027] The first conduit 21 comprises a first delimiting wall 25 that faces the first surface 311 and defines a concavity turned toward the first surface 311. Analogously, the first conduit 21 comprises a second delimiting wall 26 of that faces the second surface 312 and defines a concavity turned toward the second surface 312.

[0028] The first rib 31 connects to remaining parts of the monolithic body at a first and a second end 317, 318 thereof, which are reciprocally opposite. The first end 317 is closer to an outer surface of the pump than the second end 318.

[0029] At least a transversal section that is intermediate with respect to the first and the second end 317, 318 has a smaller surface than a surface of the transversal section measured at the first and second end 317, 318. In particular, the intermediate section has a chord and/or average thickness that is/are smaller than those of the transversal section measured at the first and the second end 317, 318. The above-mentioned transversal sections are executed along planes oriented according to the direction of the fluid and transversal to the direction which joins the first and the second end 317, 318.

[0030] In a particular example embodiment, the first rib 31 has a larger transversal section at the first end 317 than at the second end 318. Conveniently, what was previously described with reference to the first rib 31 and/or the first conduit 21 can be repeated for the second rib 32 and/or the second conduit 22.

[0031] The invention thus conceived enables multiple advantages to be obtained. First of all, it permits a reduction in the overall dimensions of the pump 1. In fact, the first rib 31 (positioned in the first conduit 21) enables the delivery side of the pump 1 to be stiffened without reinforcing the thickness of the conduits. Moreover, the aerodynamic shape of the fin makes it possible to avoid sig-

nificant pressure drops on the aspirating side (and the consequent risk of cavitation) in the event that the pump functions in a reversible mode and the first conduit 21 thus acts as an aspirating conduit. The invention thus conceived is susceptible of numerous modifications and variants, all falling within the scope of the inventive concept characterising it. Moreover, all of the details may be replaced with technically equivalent elements. In practice, all of the materials used, as well as the dimensions, may be of any type, according to need.

Claims

1. A gear pump comprising:

- a housing compartment (20) of said gears which transfer energy to a fluid crossing the pump (1) ;

- a first conduit (21) which develops from the housing compartment (20), in a first operating mode said first conduit (21) being a delivery conduit; **characterised in that** it comprises a first stiffening rib (31) that crosses said first conduit (21) and is destined to divide into at least two parts the flow of fluid transiting at said first rib (31).

2. The pump according to claim 1, **characterised in that** said first stiffening rib (31) comprises a fin (310) having an aerodynamic profile.

3. The pump according to claim 1 or 2, **characterised in that** it comprises:

- a second conduit (22) which terminates in said housing compartment (20), in the first operating mode said second conduit (22) being an aspirating conduit;

- a second stiffening rib (32) crossing said second conduit (22);

the pump (1) being reversible and being able to function also in a second operating mode in which said first conduit (21) becomes an aspirating conduit and said second conduit (22) becomes a delivery conduit.

4. The pump according to claim 3, **characterised in that** said second stiffening rib (32) comprises a fin (320) having an aerodynamic profile.

5. The pump according to any one of the preceding claims, **characterised in that** said first conduit (21) and said first rib (31) are in a single monolithic body.

6. The pump according to claim 3 or 4, **characterised in that** said first conduit (21), said second conduit

(22), said first and second rib (31, 32) and at least a part of the housing compartment (20) are in a single monolithic body.

7. The pump according to claim 3 or 4 or 6, **characterised in that** said first conduit (21), said second conduit (22), said first and second rib (31, 32) and at least a part of the housing compartment (20) are symmetrical with respect to a median plane (4) interposed between the first and the second conduit (21, 22).

8. The pump according to any one of the preceding claims, **characterised in that** said first rib (31) comprises:

- a first and a second surface (311, 312) that are mutually opposite one another;
- a leading edge (313) and an exit edge (314) of the first rib (31) which are rounded and which reciprocally connect the first and the second surface (311,312).

9. The pump according to claim 8, **characterised in that** with respect to a path that goes from the housing compartment (20) towards an outside of the pump (1) along the first conduit (21), the first rib (31) comprises:

- a portion (315) in which the first and the second surface (311, 312) are reciprocally divergent; and
- a portion (316) in which the first and the second surface (311, 312) are reciprocally convergent.

10. The pump according to claim 5 or 6, **characterised in that** said first rib (31) connects to remaining parts of the monolithic body at a first and a second end (317, 318) thereof, reciprocally opposite; at least a transversal section that is intermediate with respect to the first and the second end (317, 318) having a smaller surface than a surface of the transversal section measured between the first and the second end.

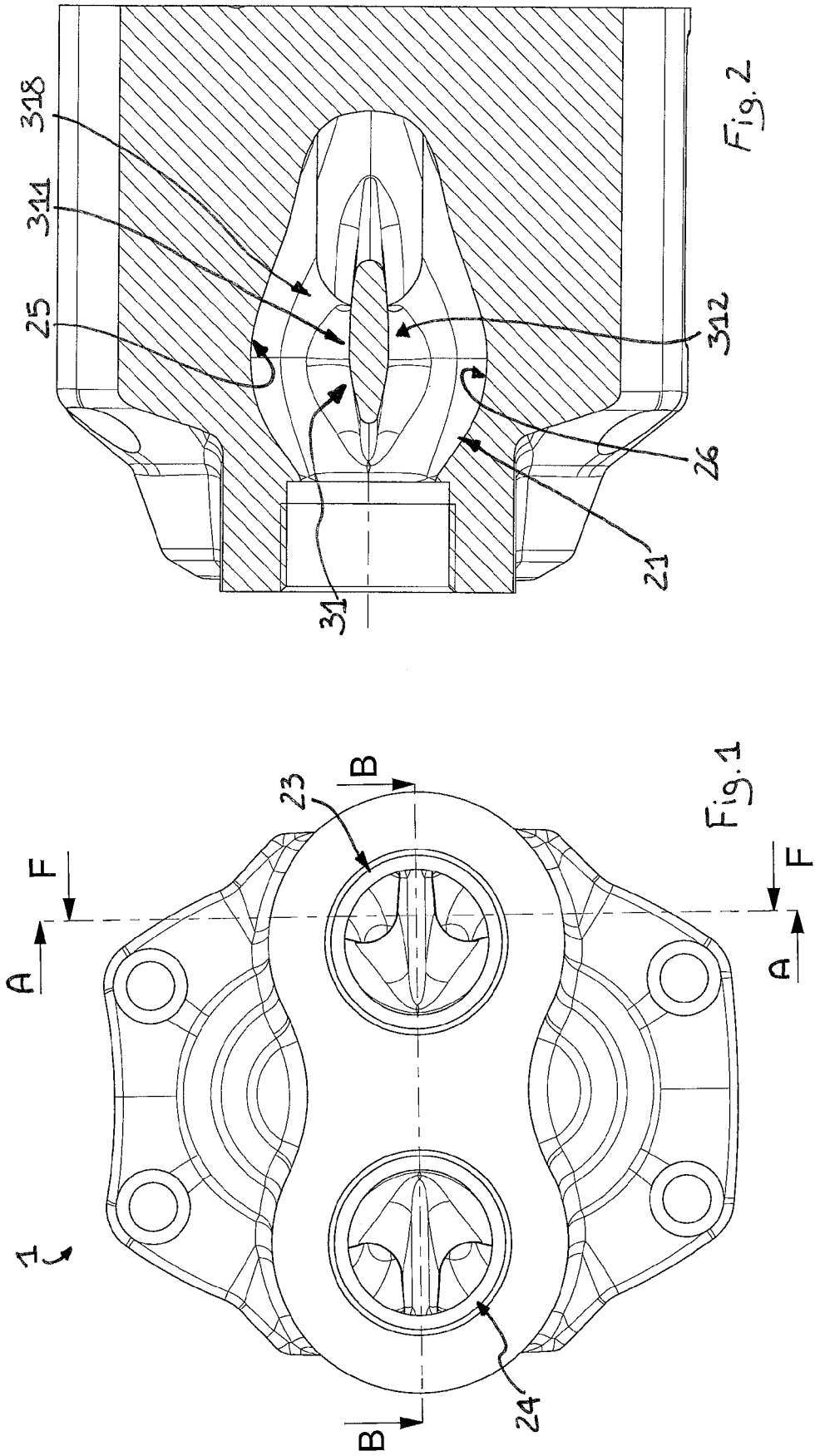

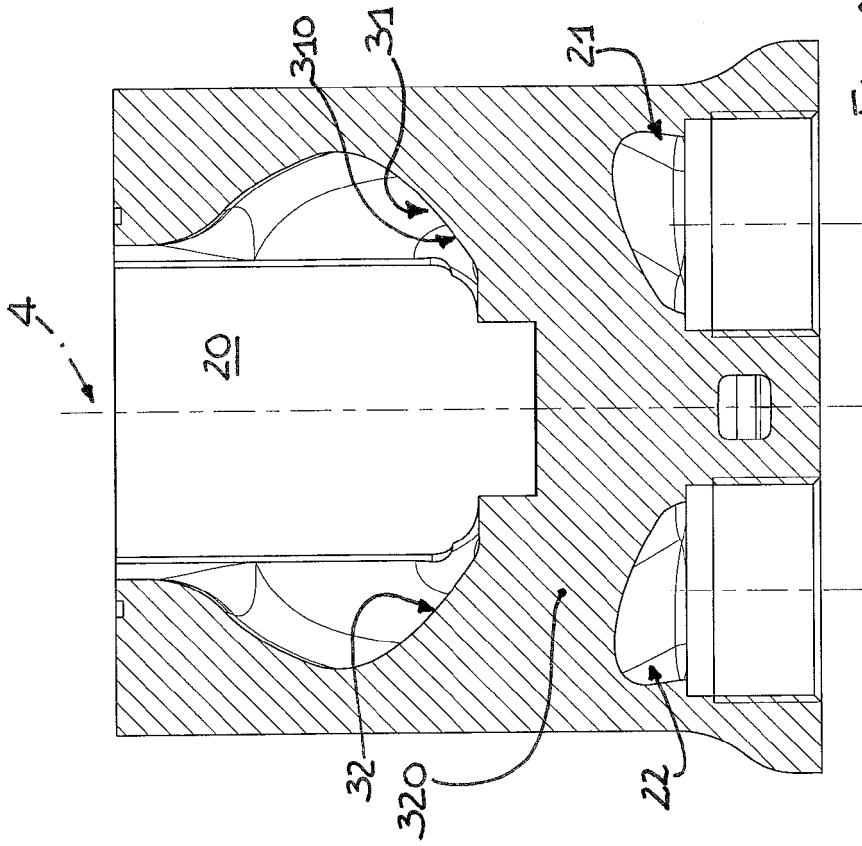

Fig. 4

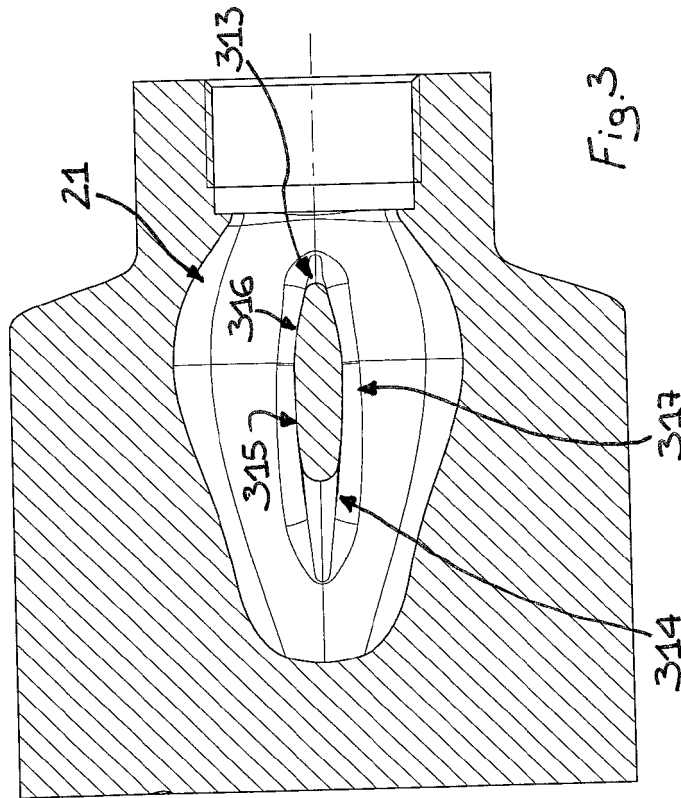

Fig. 3



EUROPEAN SEARCH REPORT

Application Number
EP 16 16 9754

5

10

15

20

25

30

35

40

45

50

55

DOCUMENTS CONSIDERED TO BE RELEVANT			
Category	Citation of document with indication, where appropriate, of relevant passages	Relevant to claim	CLASSIFICATION OF THE APPLICATION (IPC)
Y	WO 2009/126223 A2 (NESTEC SA [CH]; CULLY KEVIN J [US]; WIECZOREK SVEN [DE]) 15 October 2009 (2009-10-15) * paragraph [0040] * * figure 2 *	1,3,5,6	INV. F04C2/14 F04C15/06
Y	----- US 2005/106054 A1 (DANIELS MARK A [US] ET AL) 19 May 2005 (2005-05-19) * paragraphs [0011], [0013] * * figures 2,4 *	1,3,5,6	
A	----- GB 2 507 029 A (QUANTEX PATENTS LTD [GB]) 23 April 2014 (2014-04-23) * page 6, line 19 - page 7, line 5 * * page 7, line 16 - line 21 * * figures 1-10 *	1	
A	----- WO 2008/079131 A1 (CARRIER CORP [US]; FRASER BRUCE A [US]) 3 July 2008 (2008-07-03) * page 3, line 4 - line 18 * * figures 4,5 *	1	
			TECHNICAL FIELDS SEARCHED (IPC)
			F04C
The present search report has been drawn up for all claims			
Place of search Munich		Date of completion of the search 8 July 2016	Examiner Lange, Christian
CATEGORY OF CITED DOCUMENTS X : particularly relevant if taken alone Y : particularly relevant if combined with another document of the same category A : technological background O : non-written disclosure P : intermediate document		T : theory or principle underlying the invention E : earlier patent document, but published on, or after the filing date D : document cited in the application L : document cited for other reasons & : member of the same patent family, corresponding document	

EPO FORM 1503 03.02 (F04C01)

ANNEX TO THE EUROPEAN SEARCH REPORT
ON EUROPEAN PATENT APPLICATION NO.

EP 16 16 9754

5

This annex lists the patent family members relating to the patent documents cited in the above-mentioned European search report. The members are as contained in the European Patent Office EDP file on
The European Patent Office is in no way liable for these particulars which are merely given for the purpose of information.

08-07-2016

10

15

20

25

30

35

40

45

50

55

Patent document cited in search report	Publication date	Patent family member(s)	Publication date
WO 2009126223 A2	15-10-2009	AU 2009234479 A1	15-10-2009
		BR PI0911262 A2	28-07-2015
		CA 2721316 A1	15-10-2009
		CN 102014652 A	13-04-2011
		EP 2265820 A2	29-12-2010
		JP 5554321 B2	23-07-2014
		JP 2011518276 A	23-06-2011
		RU 2010145322 A	20-05-2012
		US 2011103992 A1	05-05-2011
		WO 2009126223 A2	15-10-2009
US 2005106054 A1	19-05-2005	CN 1882775 A	20-12-2006
		EP 1700037 A1	13-09-2006
		ES 2548566 T3	19-10-2015
		HK 1101710 A1	23-03-2012
		JP 2007528960 A	18-10-2007
		KR 20060069888 A	22-06-2006
		US 2005106054 A1	19-05-2005
		WO 2005047693 A1	26-05-2005
GB 2507029 A	23-04-2014	NONE	
WO 2008079131 A1	03-07-2008	CN 101778999 A	14-07-2010
		EP 2097615 A1	09-09-2009
		HK 1146418 A1	24-02-2012
		US 2010135839 A1	03-06-2010
		WO 2008079131 A1	03-07-2008