

July 14, 1964

D. N. ARNDT ETAL

3,140,794

FUEL TANK CAP

Filed June 22, 1962

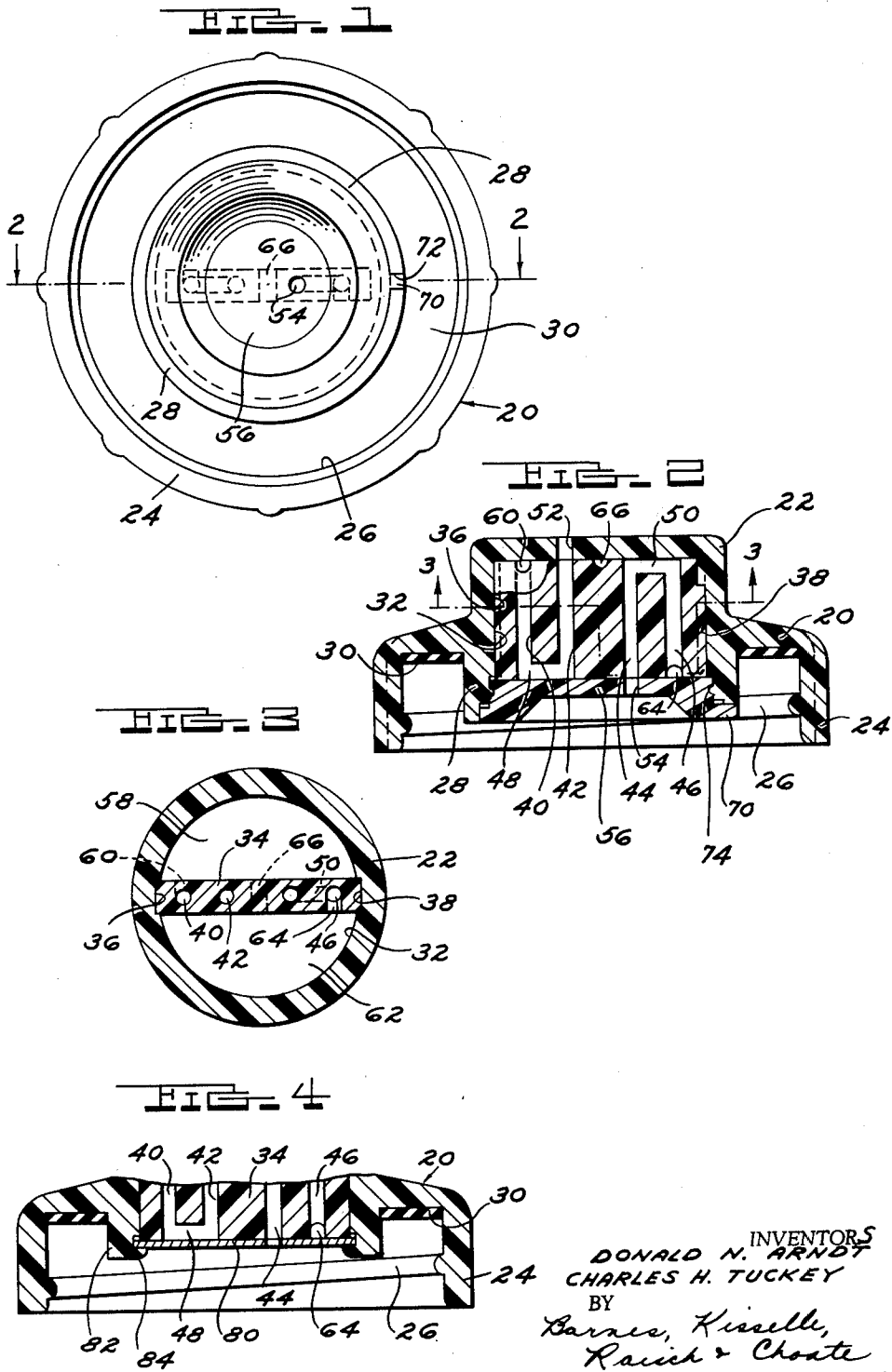

INVENTORS
DONALD N. ARNDT
CHARLES H. TUCKEY
BY
*Barner, Kissell,
Rauich & Choate*
ATTORNEYS

1

3,140,794

FUEL TANK CAP

Donald N. Arndt and Charles H. Tuckey, Cass City, Mich., assignors to Walbro Corporation, Cass City, Mich., a corporation of Michigan

Filed June 22, 1962, Ser. No. 204,326

12 Claims. (Cl. 220-44)

This invention relates to a fuel tank cap and is primarily for use with small engines, such as those used on lawn mowers, go-carts, chain saws and the like.

The purpose is to improve the gas cap to prevent spewing and spilling due to splashing of the gasoline in the tank and also sometimes due to expansion of the volume of the gas in a tank which has been filled cold and then allowed to sit in the sun.

It is important, of course, that the gasoline in a tank of this kind be subject to atmospheric pressure on its surface so that an air tight gas cap cannot be used. The problem then is to provide a suitable opening to atmosphere which will not at the same time allow gasoline to fountain out or to spill out due to vibration, sloshing, and so forth.

It is an object of the present invention to provide a gas cap which insures adequate opening to atmosphere and which will also prevent the escape of the gas in a way which will be detrimental and dangerous.

It is a further object to provide a gas cap of the type described which is reasonably inexpensive in its initial cost and which has its parts well sealed to avoid tampering or interference with the expected action.

Other objects and features of the invention relating to details of construction and operation will be apparent in the following description and claims.

Drawings accompany the disclosure and the various views thereof may be briefly described as:

FIGURE 1, a bottom view of the cap.

FIGURE 2, a sectional view on line 2-2 of FIGURE 1.

FIGURE 3, a sectional view on line 3-3 of FIGURE 2.

FIGURE 4, a view of a modified construction showing an alteration in the sealing disc.

Referring to the drawings:

Referring to FIGURES 1 and 2, the drawings show a body portion 20 having a crown portion 22. The body portion has an outer skirt 24 with an internal thread 26 and an inner skirt 28 forming an annular recess at the top of which is mounted a sealing ring 30. The crown portion 22, together with the body portion 20 and the skirt 28, form a cylindrical internal chamber 32. Within this chamber is diametrically located a vent block 34, this block being fixed by location in opposed recesses 36 and 38 to serve as a dividing wall or septum in the recess 32. The vent block has four parallel passages 40, 42, 44 and 46 which extend from the top to the bottom of the vent block as it is viewed in FIGURE 2.

Passages 40 and 42 are connected at the bottom of the block by a cross passage 48, and passages 44 and 46 are connected at the top of the block by a cross passage 50. Thus, two U-shaped, labyrinth passages result, one U upright, the other invertable. Passage 42 terminates in a port 52 through the top of the crown portion 22 and passage 44 terminates at the bottom in a port 54 in a closing and retaining disc 56. The top of passage 40 is connected to a recess 58 (FIGURE 3) on one side of the vent block 34 by a short port 60 at the top of the recess. Passage 46 is connected to a recess 62 on the other side of the vent block by a short port 64 at the bottom of the recess. Chambers 58 and 62 are also connected through a small groove 66 at the top of the vent block (see FIGURES 2 and 3).

In FIGURE 2 the sealing disc 56 has a short radial tab

2

70 which extends into a notch 72 in the rim of skirt 28. On a cylindrical wall of the disc 56 is a groove 74 which cooperates with an annular bead on the inside of skirt 28 to lock the disc 56 in place. The disc thus holds the vent block 34 in position in the grooves 36, 38 in the dome 22.

In FIGURE 4, a modified construction shows a simple metal disc 80 which holds the vent block 34 in position, this disc being located in a skirt 82, the structure of the cap being otherwise the same as in the other drawing. The disc 80 is held in place by annular portions 84 of the skirt which are formed inwardly under heat to lock the disc in place.

It will thus be seen that with the structure disclosed a passage for atmospheric pressure to the interior of the tank follows port 52, passages 42, 48 and 40 to the port 60 leading to chamber 58. Chamber 58 is connected through the cross passage 66 to chamber 62 which is connected to the interior of the tank through port 64 and passages 46, 50 and 44 leading to the internal port 54 in disc 56. It will thus be seen that it is impossible for gasoline which might be splashed into the port 64 to be spewed out of the port 52 since it must move through the passages described. In addition, any gasoline that might accumulate in chamber 62 by reason of expansion or splashing will be carried back into the gasoline tank by influx of air as the gasoline level goes down in the tank from use, while relieving the suction that would otherwise be created in the tank.

The material from which the parts above described can be made is preferably a molded plastic material which adapts itself to the formation of the various parts. The disc 80 can be a relatively thin metal plate, such as zinc or any metal which is noncorrosive in the presence of fuel. It is important that the surfaces of contact between the vent block 34 and the top of the dome 22 and the top of the retaining disc have a sealing relationship in order that the chambers 58 and 62 are not connected except at the cross passage 66. The discs 56 or 80 should also have a sealing relationship at their periphery with the respective skirts 28 and 82. It will thus be seen that the gas cap with a relatively simple construction provides adequate atmospheric relief while preventing the splashing or spewing of fuel from the tank.

We claim:

1. A gas cap comprising:
 - (a) a body having a threaded portion to have a sealing relation with a complementary threaded portion of a gas tank, said body having an internal chamber divided by a septum, said chamber having an opening in the top outside wall for atmosphere and an opening in the bottom inside wall.
 - (b) means forming a U-shaped passage to connect each of said openings to recesses on opposite sides of said septum, and
 - (c) means forming a passage through said septum at the top of said chamber.
2. A gas cap comprising:
 - (a) a body having a threaded portion to have a sealing relation with a complementary threaded portion of a gas tank, said body having an internal chamber divided by a septum to divide the chamber into a first and second recess,
 - (b) a first opening in the top wall of said chamber and a second opening in the bottom wall of said chamber,
 - (c) means forming a U-shaped passage connecting said first opening adjacent the top of said chamber to one of said recesses,
 - (d) means forming a U-shaped passage connecting said second opening adjacent the bottom wall of said chamber to said other recess, and
 - (e) means forming a passage to connect said recesses

3

- independently of said U-shaped passages adjacent the top of said chamber.
3. A device as defined in claim 2 in which said U-shaped passages and said passage connecting said recesses are formed in said septum.
4. A gas cap comprising:
- (a) a body having a threaded portion to have a sealing relation with a complementary threaded portion of a gas tank, said body having an internal chamber divided by a septum to divide said chamber into separate recesses,
 - (b) a first opening at the top of said chamber,
 - (c) a second opening at the bottom of said chamber,
 - (d) a labyrinthal passage connecting said first opening adjacent the top of said chamber to one of said recesses,
 - (e) a second labyrinthal passage connecting said second opening to the other of said recesses adjacent the bottom of said chamber, and
 - (f) a cross port independent of said passages connecting said recesses adjacent the top of said chamber.
5. A gas cap having:
- (a) a threaded portion to have a sealing relation with a complementary portion of a gas tank comprising:
 - (b) a body having a cylindrical chamber,
 - (c) a septum dividing said chamber into two substantially equal recesses, said septum being placed diametrically in said chamber,
 - (d) a bottom sealing discs to close said chamber and to hold said septum in its position, said septum having two spaced U-shaped passages, one being an upright U and the other an inverted U, one end of each U-shaped passage being connected at the end of a leg with opposite recesses and the other leg of each U being connected to atmosphere at the top and bottom respectively of said chamber, and a cross port in said septum connecting said recesses.
6. A gas cap comprising:
- (a) a body having a threaded portion for cooperation with a threaded opening in a gas tank with means, for sealing the threaded portion wherein the interior of the tank is exposed to the interior of the gas cap in an air tight connection, said body having a portion forming a closed chamber with top and bottom walls each having a port therethrough,
 - (b) means to divide said closed chamber into two recesses connected through a passage adjacent the top wall,
 - (c) means forming a first labyrinthal passage to connect the port in the top wall with one of said recesses adjacent the top of said one recess,
 - (d) means forming a second labyrinthal passage to connect the port in the bottom wall with the other of said recesses adjacent the bottom of said other recess whereby venting air can pass through said ports and passages in either direction.

4

7. A gas cap as defined in claim 6 in which said passages are formed in said means to divide said closed chamber.
8. A gas cap as defined in claim 6 in which said first labyrinthal passage is in the form of an upright U, and said second labyrinthal passage is in the form of an inverted U.
9. A gas cap as defined in claim 6 in which the said body is formed as an inverted cup having a closing wall at the bottom thereof to enclose said chamber.
10. A vent cap for closing a fill opening of a container for liquids comprising:
- (a) a body having;
 - (1) an annular portion threaded for cooperation with a threaded gravity fill opening in the top of the container wherein the headspace of the container is exposed to the interior of the cap in a liquid tight connection,
 - (2) a portion defining an axially extending air chamber in the body, and
 - (3) a top wall portion closing the upper end of the chamber and having an air vent opening therethrough;
 - (b) a bottom wall closing the lower end of the chamber and having an air vent opening therethrough;
 - (c) and partition means disposed within said chamber intermediate said top and bottom walls defining an upright generally U-shaped passage and an inverted generally U-shaped passage providing sealed air passages leading respectively from said top and bottom wall vents to the interior of said chamber, said upright U-shaped passage having an outlet opening to the chamber adjacent said top wall and said inverted U-shaped passage having an opening to the chamber adjacent said bottom wall, said outlets of said passages being spaced horizontally from one another and communicating with one another via said chamber.
11. The cap set forth in claim 10 wherein said bottom wall comprises a disc-like part assembled in sealed relation against the lower end of said air chamber portion of the body.
12. The cap set forth in claim 11 wherein said threaded portion of the body comprises a cylindrical skirt having an internal thread formed therein and a flange joined in sealed relation to and extending radially inwardly from said skirt, and said air chamber portion comprises an upright wall joined in sealed relation to the inner periphery of said flange and projecting axially beyond the exterior side of said flange.

References Cited in the file of this patent

FOREIGN PATENTS

289,414 Italy ----- Oct. 16, 1931