

(12) INTERNATIONAL APPLICATION PUBLISHED UNDER THE PATENT COOPERATION TREATY (PCT)

(19) World Intellectual Property Organization
International Bureau



(43) International Publication Date
23 October 2003 (23.10.2003)

PCT

(10) International Publication Number
WO 03/086151 A1

(51) International Patent Classification⁷: **A47C 19/02**

Micheal, S. [US/US]; 1304 Amanda Circle, Decatur, GA 30033 (US).

(21) International Application Number: PCT/US03/11597

(74) Agents: **KELLY, Edward, J.** et al.; Ropes & Gray, One International Place, Boston, MA 02110-2624 (US).

(22) International Filing Date: 14 April 2003 (14.04.2003)

(25) Filing Language: English

(81) Designated States (*national*): AE, AG, AL, AM, AT, AU, AZ, BA, BB, BG, BR, BY, BZ, CA, CH, CN, CO, CR, CU, CZ, DE, DK, DM, DZ, EC, EE, ES, FI, GB, GD, GE, GH, GM, HR, HU, ID, IL, IN, IS, JP, KE, KG, KP, KR, KZ, LC, LK, LR, LS, LT, LU, LV, MA, MD, MG, MK, MN, MW, MX, MZ, NO, NZ, OM, PH, PL, PT, RO, RU, SD, SE, SG, SK, SL, TJ, TM, TN, TR, TT, TZ, UA, UG, US, UZ, VC, VN, YU, ZA, ZM, ZW.

(26) Publication Language: English

(30) Priority Data:
60/371,969 12 April 2002 (12.04.2002) US

(71) Applicant (*for all designated States except US*): **DREAMWELL, LTD.** [US/US]; 2325-B Renaissance Drive, Las Vegas, NV 89119 (US).

(72) Inventors; and

(84) Designated States (*regional*): ARIPO patent (GH, GM, KE, LS, MW, MZ, SD, SL, SZ, TZ, UG, ZM, ZW), Eurasian patent (AM, AZ, BY, KG, KZ, MD, RU, TJ, TM), European patent (AT, BE, BG, CH, CY, CZ, DE, DK, EE, ES, FI, FR, GB, GR, HU, IE, IT, LU, MC, NL, PT, RO, SE, SI, SK, TR), OAPI patent (BF, BJ, CF, CG, CI, CM, GA, GN, GQ, GW, ML, MR, NE, SN, TD, TG).

(75) Inventors/Applicants (*for US only*): **HELLYER, Robert** [US/US]; 490 Thornwyck Trail, Roswell, GA 30076 (US). **EITEL, Charles** [US/US]; 3260 West Paces Park Court, Atlanta, GA 30327 (US). **DAMEWOOD, Kevin** [US/US]; 8620 Havenwood Trail, Rosewall, GA 30076 (US). **KUCHEL, Bernhard, W.** [US/US]; 2470 Bermuda Road, Stone Mountain, GA 30087 (US). **DEFRANKS,**

Published:
— with international search report

[Continued on next page]

(54) Title: CASSETTE BEDDING SYSTEM

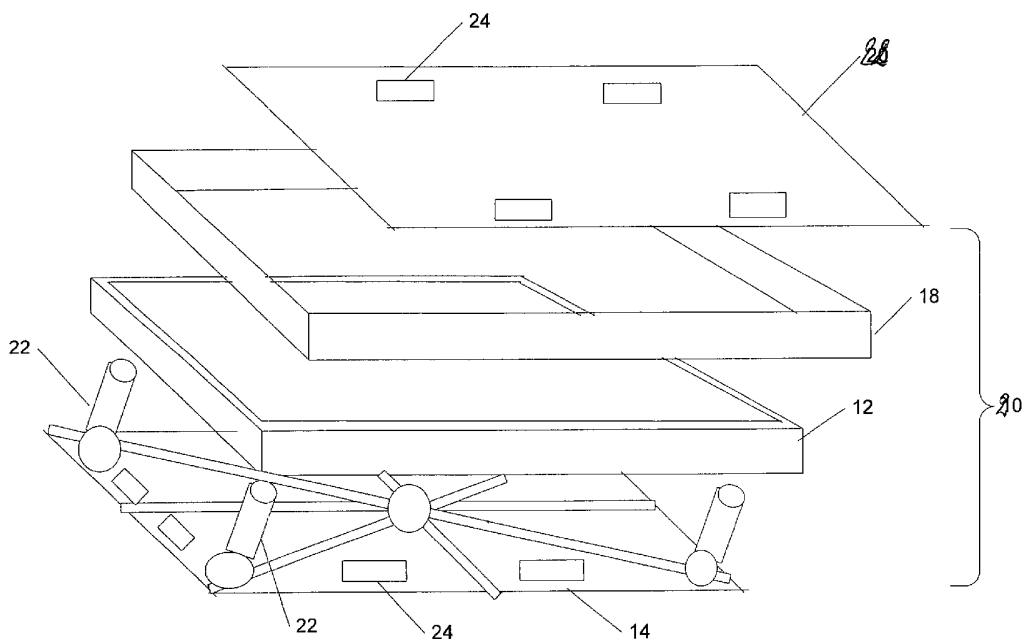

(57) Abstract: A bedding system that provides ease of handling and transport and reduces storage space, and includes a foundation (11) in the form of a shell comprising a top panel and a side panel (18), a mattress (12) having a transport size to fit inside the shell so that the foundation (11) and mattress (12) can be transported as a single unit having the outside dimensions of the foundation. When in set up as a bed, the mattress is placed on the top panel of the foundation. A bracing system (72) is provided that attaches to the sidewalls (18) of the foundation (11) to provide a foundation sufficiently strong to support a mattress and one or more users.



WO 03/086151 A1



For two-letter codes and other abbreviations, refer to the "Guidance Notes on Codes and Abbreviations" appearing at the beginning of each regular issue of the PCT Gazette.

CASSETTE BEDDING SYSTEM

CLAIM TO EARLIER FILED RELATED PATENT APPLICATION

5 This application claims priority to earlier filed patent application 60/371,969, filed April 12, 2002, the contents of which are hereby incorporated by reference.

FIELD OF THE INVENTION

The systems and methods described herein relate to a bedding system, and more particularly to a
10 cassette bedding system for easier storage, handling and transport.

BACKGROUND OF THE INVENTION

Conventional beds typically include a steel or wood frame, optionally with casters, on
15 which a box spring is positioned. A mattress is, in turn, placed on the box spring. Beds of this type come in various sizes and can be quite bulky to package and transport. The height of the box spring is typically approximately equal to the height of the mattress. A Mattress and box spring, hereinafter referred to as a bedding system, are still mostly purchased at department stores and furniture stores. However, an increasing number of purchases are being made
20 through alternative distribution chains, such as membership warehouse outlets and discounters.

Typically, purchases made at outlets and discounters are “cash and carry”, whereby the customer is expected to remove the item from the store at the time of purchase and provide his/her own transportation to the place where the bedding system is to be set up. While limited
25 store help may be available, the customer is essentially responsible for handling the bedding system at all times. Many customers may not be capable of or comfortable with handling the

bedding system and thus choose to purchase products through retailers that provide shipping and handling, even at extra cost. Accordingly, cash and carry outlets tend to lose potential sales due to the unwieldy nature of bedding systems.

5 Warehouse outlets tend to keep a substantial inventory on hand. In addition, bedding systems are typically stacked loosely and due to their size, take up valuable floor space, in particular since the items are preferably openly displayed such that customers can readily help themselves. Accordingly, the size of the bedding system can limit the outlet's ability to use floor space efficiently. To address these problems, engineers have developed packaging systems
10 that use the foundation as a package that can be used to transport the mattress. One such system is shown in US Patent 5,237,714. As described therein a fiberboard foundation is provided that can also be used as a shipping crate. Similarly, US patent 5,271,498 describes a mattress packaging system that allows a plurality of mattresses to be stacked onto a palette for more convenient transport.

15 Although such prior art systems can ease the difficulty of transporting and storing a plurality of bedding systems, none of these systems provides the end consumer with a bedding system that can be brought home and assembled into a conventional bed.

Accordingly, there is a need in the art for a bedding system that takes up less storage space and hence is more suited for sale through warehouse outlets and discounters.

20

SUMMARY OF THE INVENTION

The bedding systems and, the foundations and mattresses described herein, are configured for easy transport and handling and space-saving storage. The bedding system includes a protective shell, that may be water proof and sufficiently large to hold a mattress.

25

More particularly, the systems and methods described herein include a bedding system that has a foundation in the form of a shell comprising a top panel and a side panel and having a mattress in a transport size that fits in the shell so that the foundation and mattress are transported as a single unit that has the outside dimension of the foundation, and the mattress
5 may be placed on the top panel of the foundation when set up as a bed.

Optionally, the bedding system may have a transport size wherein the mattress is smaller than the useful of the mattress when the bed is setup. The side of the mattress may be reduced by compression, either by application of a vacuum or by mechanical compression. In one
10 practice the mattress is compressed by placing the mattress inside an enclosure made of an air barrier and applying a vacuum pressure to the inside of the enclosure.

With the systems and methods described herein, the mattress used may be a foam mattress, a pocketed coil mattress, an open coil mattress, or any other kind of suitable mattress.
15

In another aspect, the systems and methods described herein will be understood to include methods for packaging of bedding system that comprise steps of providing a foundation in the form of a shell having a top panel and a side panel and placing a mattress having exterior dimensions to fit inside the shell wherein the foundation and mattress are transported as a single
20 unit having the outside dimensions of the foundation and wherein the mattress may be placed on the top panel of the foundation when in use.

In a further aspect, it will be understood that the systems and methods described herein include methods for transporting a bedding system which include providing a foundation in the
25 form of a shell comprising at least a top panel and side panel, placing a mattress having exterior dimensions to fit inside the shell wherein the foundation and mattress is transported as a single

unit having the outside dimensions of the foundation and securing casters to the foundation to allow transport of the bedding system.

BRIEF DESCRIPTION OF THE FIGURES

5

The foregoing and other objects and advantages of the invention will be appreciated more fully from the following further description thereof, with reference to the accompanying drawings wherein:

10 FIG. 1 depicts a conventional bedding system with a mattress and a foundation resting on a frame;

FIG. 2 shows in a perspective exploded view one exemplary bedding system according to one embodiment of the invention in a transport configuration;

15

FIG. 3 depicts a foundation with reinforcement braces and casters for a bedding system according to the invention;

FIG. 4 depicts the bedding system of FIG. 3 with a mattress and with the reinforcement
20 braces in a transport position;

FIG. 5 depicts another embodiment of a foundation for the bedding system according to the invention;

25 FIG. 6 depicts the bedding system of FIG. 4 with the mattress packaged for transport/storage;

FIG. 7 depicts an exemplary foam mattress for use with the bedding system; and

FIG. 8 depicts a palletted bedding system, using one bedding system in a horizontal

5 orientation as a pallet.

DETAILED DESCRIPTION OF ILLUSTRATED EMBODIMENTS

To provide an overall understanding of the invention, certain illustrative embodiments
10 will now be described. These embodiments include, but are not limited to, bedding systems that
include a mattress and a foundation and that may be configured for more efficient shipping,
handling and storage and then easily reconfigured into a conventional bed with a mattress and a
foundation. This mattress may be one-sided, or two-sided, foam, pocketed coil, open coil, an air
mattress or a water mattress. Thus, it will be understood by one of ordinary skill in the art that
15 the systems and methods described herein can be adapted and modified for other suitable
applications and that such other additions and modifications will not depart from the scope
hereof.

Turning now to FIG. 1, a conventional bedding system 10, as placed for example on the
20 floor of a bedroom, typically includes a foundation 11 and a mattress 12 which rests on the
foundation 11. As shown in FIG. 1, the foundation 11 can additionally be placed on a frame 15
which can include a set of casters to facilitate moving the bedding system, for example, for
cleaning the bedroom floor. The foundation 11 can be implemented as a box spring or can be
any surface or structure to provide a rigid support for the mattress 12. As mentioned before, the
25 mattress 12 and the foundation 11 depicted in FIG. 1 are typically handled and stored as separate
units.

FIG. 2 depicts in a perspective exploded view a first exemplary embodiment of a bedding system 20 according to the invention, shown here in a transport configuration. The bedding system 20 includes a mattress 12, and a foundation comprised of a foundation bottom 14, a foundation sidewall 18, a foundation top 22 and a plurality of optional support posts 22. The foundation bottom 14, the foundation sidewall 18 and the foundation top 22, when assembled, form a shell-like structure adapted to receive and contain the mattress 12 for transport. The foundation bottom 14 and foundation sidewall 18 may be joined together permanently as a single piece, or may be separate pieces to be joined later.

10

FIG. 2 shows the foundation top 22 as a separate removable piece. In other embodiments (not shown) the foundation top 22 may be hingedly secured to the foundation sidewall 18 or slidably secured in a groove provided in the foundation sidewall 18. The foundation top 22 may also be omitted entirely. In a further alternative embodiment the foundation may be formed as a box that has a removable and replaceable side wall thereby allowing the mattress to be slid in and out of the foundation. The support posts 22 can be inserted in matching recesses disposed at suitable locations in the foundation bottom 14 and the foundation top 22 to maintain in an assembled state a uniform spacing between the foundation bottom 14 and the top 22 and to provide additional support for the surface of the foundation that will face the mattress 12 after assembly. It will be understood that the designation as foundation bottom 14 and foundation top 22 does not necessarily indicate the orientation of the foundation when set up as a bed.

15

20

25

FIG. 3 shows a perspective bottom view of another embodiment of a foundation 11. In this embodiment, the support posts 22 have been replaced by web-like spacers or support braces 72 to aid in supporting the foundation top 22. The braces 72 can be designed to lock into place

once inserted in, for example, the foundation sidewall 18 and/or may be removable and re-insertable. While the illustrated embodiment shows two support braces 72 which snap into the side walls of foundation 60, it is understood that the number of support posts 22 and support braces 76, their location, size and desired attachment locations with respect to the foundation 11 may be varied as desired. For example, in one alternate embodiment, the braces 72 extend diagonally from one corner of the foundation 22 to another, thereby forming an "X-brace" support. In either case it will be understood that the systems described herein may include an interior brace structure that can connect to and engage with the sides of the frame to provide sufficient reinforcement of the upper foundation surface 22 and the foundation side walls 18 to allow the foundation to support the weight of a conventional steel spring mattress and the expected number of bed occupants. To this end, the foundation includes, in one preferred embodiment, braces 72 that can engage into slots 73 that are molded into the sidewall 18. As shown in figure 3, the braces 72 can be slidingly engaged into slots 73 that are positioned in opposite side walls of the foundation 11. The fixed length of the braces 72 hold the side walls of the foundation a fixed length apart and prevent, or greatly reduce, the ability and tendency of the foundation side walls to spread or twist in response to the application of a load. Additionally, Figure 3 also shows that the braces 72 are fitted against the underside of the foundation top 22. Accordingly, the braces 72 support the foundation top 22 and prevent or reduce, inward deflection of the foundation top 22 in response to an applied load. In one embodiment, the braces 72 are molded plastic I-beams of approximately the same width as the sidewall 18. In alternate embodiments, the bracing may be formed as part of the mold. Thus, the sidewalls may be somewhat deep than the mattress 12. This extra deep leaves room for braces to be molded into the foundation. In one example the depth of the foundation is 2 to 3 inches greater than the height of the mattress 12. This extra 2-3 inches allows for the braces 72 to be formed as integral parts of the foundation. The difference in depth between the foundation and the mattress may be

achieved by making the sidewalls larger, reducing the thickness of the mattress, compacting the mattress for storage, or by any combination of the techniques.

Referring now to FIG. 4, the support braces 72, like the posts 22, may be stored for
5 transport inside the foundation 11, where they use very little space, and inserted only when the foundation is assembled at the customer's site. Alternatively, the braces 72 and/or posts 22 can be placed along the outside of the foundation 11 (not shown).

Since the depicted foundation 11 is essentially a hollow shell, it may conveniently be
10 used as storage space once the bedding system 20 is set up. For this purpose, side doors (not shown) can be placed at suitable locations in the foundation sidewall 18. The side doors can be sliding doors, hinged doors or any suitable door configuration known in the art. Additionally, the foundation 11 can have cutouts 24 (see FIG. 2) disposed in the foundation top 22 and foundation bottom 14 to facilitate handling or for tying-down the bedding system during
15 transport. Cutouts could also be provided in the foundation sidewall 18. In any case, the foundation 11 in one embodiment is a plastic molded frame. The walls and top of the frame are sufficiently thick to support a conventional steel spring mattress and in one embodiment the foundation 22 can support between 750 and 1500 lbs. As the foundation may be covered with a slip cover, the side cutouts 24 will be covered and will not detract from the appearance of the bed
20 once it is set up. Consequently, the cutouts 24, and other similar features, such as plastic D-rings can be added to the foundation 11 to facilitate transport. In one alternate embodiment, the foundation includes bulbous skids made preferably of a low coefficient of friction material and formed on the sidewall or bottom wall of the foundation. These skids allow the bed to be slid across the surface of a store floor, thereby allowing the consumer to more easily move the
25 product to their car.

In most cases the product will be covered with a plastic wrap packaging. The plastic can be heat shrink wrapping, or conventional plastic wrapping. In one optional embodiment, the foundation 11 may include countersunk nuts which can receive bolt on features, such as handles, straps, casters or D-rings. The bolt on features can be attached through the plastic wrapping by a bolt or machine screw that can penetrate through the wrapping. The bolt on feature can be temporarily screwed into the counter sunk bolt for helping the consumer deliver the product.

Referring back to FIG. 3, optional casters 74 can be attached to the bottom of the foundation 11, for example, to the foundation sidewall 18 or to the foundation bottom 14. The casters 74 can be designed for transport purposes only or can be left in place after setup of the bedding system 10 to allow the bedding system to be moved. Additional casters 76 may be attached to the support braces 72 to provide additional support of the mattress. The casters 74, 76 may be removable and re-insertable. These casters are optional and the foundation 11 may be seated directly on the floor. Alternatively, legs may be provided that can be bolted or otherwise attached, to the foundation 11 to lift the foundation 11 off the floor. Legs and casters may be positioned around the periphery of the foundation 11 as shown in Fig. 3, and may also be located along the length of the braces 72. For example, in the embodiment where the braces 72 form an X-brace, a leg or caster may be centrally positioned to provide support for the middle of the foundation 11. Optionally, a fabric skirt can be provided that fits over the exterior surface of the foundation 11 and provides an improved aesthetic appearance.

In another exemplary embodiment of the bedding system 20, depicted in FIG. 5, casters 78 may be placed along a sidewall 18 of the foundation 11. With this arrangement of casters 78, the foundation 11 can be moved and stored in an upright position. With the mattress 12 placed inside the foundation 11, as shown in FIGS. 2 and 4, and also in FIG. 6, the entire bedding system 10 can hence be easily stored upright, taking up no more space than the foundation alone,

translating into a savings of at least 50% in storage space. The casters 74, 76, like the support post and braces 72, can be packaged inside the foundation 60 for transport and storage. In a further optional embodiment as discussed above, the casters 74 may be replaced with furniture legs to lift the frame off the floor. This allows for easy vacuuming under the bed. In this
5 embodiment a furniture leg may be any suitable length, for example between 3 and 9 inches long. A leg may be fitted into the caster groove at each corner of the frame 11. Additionally and optionally, a fifth leg may be provided that can be centrally located and provide further support for the center of the foundation 11.

10 In addition to casters and legs, the foundation 11 may also be provided with head and foot boards. The foundation 11 can include hardware for attaching a head or foot board, or can be adapted to allow the head board or foot board to be snapped or forced into place. Further, in
15 other optional embodiments, the foundation 11 may be capable of being separated into two or more pieces. To this end, the foundation 11 may comprise two sections of equal size. The two sections may be joined at the center by any suitable technique, such as bolting the two pieces together or snapping them together. In one embodiment, each section is half the width and the full length of the foundation 11. When separated into two pieces, the foundation 11, which may be a California king, king, Olympic queen, queen, full or twin size bed, may be more easily moved through the consumer's home.

20 Although Figs. 3-6 depict the foundation 11 and braces 72 as being formed of perforated sheets of plastic, it will be understood that in other embodiments, the foundation 11 and braces 72 may comprise solid sheets of plastic, or a combination of solid and perforated sheets. In one embodiment the foundation comprises a unitary body having a top surface and sidewalls as depicted in Fig. 3. In this embodiment, the mattress 12 may be vacuum compressed to reduce its
25 size to a size adapted for fitting within the internal cavity of the foundation 11. This size and

configuration is more suited to transport, and the unitary plastic body of the foundation 11 acts as a protective shell for the mattress 12.

The mattress 12 may be a conventional mattress, such as an open coil mattress, a Marshall coil mattress, a foam mattress, or an air or water bed mattress, while the foundation can be made, for example, of plastic, wood, composite materials, fiberglass, metal, and/or other suitable materials known in the art. The bedding system 10 can be of any suitable size, for example, a queen size with a total weight of about between 40 and 70 lbs. The bedding system 10 may also include a slip cover (not shown) fitted over the foundation to provide a more aesthetically pleasing appearance. For transport, the slip cover may be placed over the foundation, whereby fabric or plastic handles on the slip cover can facilitate gripping the bedding system. As mentioned above, the foundation can also have cutouts 24 that improve handling of the bedding system when in its transport configuration.

FIG. 7 depicts an exemplary mattress 12, for example a foam mattress, adapted to be placed inside the foundation 11. Foam mattresses are known in the art. The mattress 12 depicted in FIG. 7 can include a number of different support sections 22, 24, 26, 28, 30 which can be surrounded laterally by a peripheral section 32. Sections 22, 24, 26, 28 and 30 can be of different firmness and be arranged such that different body sections of a user are supported by corresponding sections with a specific firmness. For example, section 22 may have a suitable firmness to support the upper back of a user. Section 26 may have a different firmness that is more suited for supporting the user's lumbar region. Other sections of the mattress 12 can have a firmness suitable for supporting other body sections. The peripheral section 32 can provide additional edge support for the mattress 12. The peripheral section can have a firmness that is greater than the firmness of the interior foam sections 22, 24, 26, 28, 30.

The linear dimensions of the mattress 12, can be significantly reduced by compressing the mattress. In certain practices, the height, width and length of the mattress may be reduced. In one practice, the size of the mattress 12 can be reduced by sealing the mattress 12 in a plastic package under vacuum. The plastic package can be made of a plastic sheet of sufficient strength to withstand the pressure differential between the vacuum inside the package and atmospheric pressure, and also resist puncture and tearing. Any material that acts as a suitable air barrier may be used. In certain embodiments, the package comprises a poly laminate material, or other nylon-based material. The vacuum can also keep contaminants and moisture away from the mattress 12 and provides a sanitary seal for the mattress 12. The vacuum-sealed mattress 12 will hence easily fit inside the interior space of the foundation and will expand to its intended size when removed from the package. It will be understood that the ability to vacuum-seal the mattress and the size reduction under an applied vacuum depends on the type of mattress. Vacuum shall refer to any suitable pressure below ambient pressure. Alternatively or in addition, the mattress can also be compressed mechanically. Mechanical compression systems are known in the art, including those described in U.S. patent 6,096,378. In another alternate embodiment, the foundation is made slightly larger to accommodate a regular sized mattress.

FIG. 8 depicts a palletized shipping block 40 with a plurality of bedding systems 10a, 10b, with each of the bedding system systems 10a, 10b being in the transport configuration. One bedding system 10a may be placed in a horizontal disposition to act as a pallet for the other bedding systems 10b which are placed on the pallet 10a. This arrangement obviated the need for a separate shipping pallet for the bedding systems 10a, 10b and reduces the shipping cost.

Those skilled in the art will know or be able to ascertain using no more than routine experimentation, many equivalents to the embodiments and practices described herein. For example, the foundation may include a handle grip, or latches for securing on the bedding system

with another for better shipping. Accordingly, it will be understood that the invention is not to be limited to the embodiments disclosed herein, but is to be interpreted as broadly as allowed under the law.

5 We claim:

CLAIMS

1. A bedding system comprising:

a plastic foundation having a top panel and four sidewalls defining an interior
5 compartment,

a mattress having useful size larger than the interior compartment and a transport size
dimensionally adapted to fit inside the plastic foundation so that the foundation and mattress are
transported as a single unit having the outside dimensions of the foundation, and the mattress is
placed on the top panel of the foundation when set up as a bed.

10

2. The bedding system of claim 1, further comprising a first and a second brace having
attachment mechanisms disposed at either end of the brace for mechanically attaching to a
sidewall of the foundation.

15

3. The bedding system of claim 1, wherein size of the mattress is reduced from the useful
size to the transport size by compression.

20

4. The bedding system of claim 1, wherein the mattress is compressed by placing the
mattress inside an enclosure made of a barrier material that is impervious to air and applying a
vacuum pressure to the inside of the enclosure.

5. The bedding system of claim 1, wherein the foundation further comprises a bottom panel,
with said bottom panel, top panel and side panel defining an enclosed foundation space.

25

6. The bedding system of claim 1, wherein the side panel is detachable from the top panel.

7. The bedding system of claim 1, wherein the side panel is detachable from the bottom panel.
8. The bedding system of claim 1, and further comprising casters attached to the foundation.
- 5 9. The bedding system of claim 8, wherein the casters are attached at a location of the side panel that faces away from the top panel.
10. The bedding system of claim 8, wherein the casters are attached on a side of the side
10 panel to facilitate transport of the bedding system in an upright orientation.
11. The bedding system of claim 8, wherein the casters are removable.
12. The bedding system of claim 1, wherein the foundation comprises a material selected
15 from the group consisting of wood, plastic, composite material and metal.
13. The bedding system of claim 1, wherein the top panel is perforated.
14. The bedding system of claim 1, and further comprising openings disposed in the side
20 panel or top panel for handling the bedding system.
15. The bedding system of claim 5, and further comprising closeable openings disposed in the side panel and providing access to the enclosed foundation space.
- 25 16. The bedding system of claim 1, and further comprising a support brace secured to an interior surface of the side panel for supporting the top panel.

17. The bedding system of claim 5, and further comprising a support post disposed between the top panel and the bottom panel for maintaining a spacing between the top panel and the bottom panel.

5

18. The bedding system of claim 16, and further comprising casters attached to the support brace at a location opposite the top panel.

19. The bedding system of claim 1, wherein the mattress is made of a foam material.

10

20. The bedding system of claim 19, wherein the foam mattress has sections of different firmness.

21. The bedding system of claim 1, wherein the mattress has an open coil or Marshall coil construction.

15

22. The bedding system of claim 1, and further comprising at least one of a support post and a support brace, wherein the at least one support post and support brace are stored inside the shell for transport of the bedding system.

20

23. Method for packaging a bedding system, comprising
providing a foundation in the form of a shell comprising at least a top panel and a side panel, and

placing a mattress having exterior dimensions to fit inside the shell,

25 wherein the foundation and mattress is transported as a single unit having the outside dimensions of the foundation, and

wherein the mattress is placed on the top panel of the foundation when in use.

24. Method for transporting a bedding system, comprising

providing a foundation in the form of a shell comprising at least a top panel and a side

5 panel,

placing a mattress having exterior dimensions to fit inside the shell,

wherein the foundation and mattress is transported as a single unit having the outside dimensions of the foundation, and

securing casters to the foundation to allow transport of the bedding system.

10

25. The method of claim 24, wherein the casters are oriented so as to face away from the top panel.

26. The method of claim 24, wherein the casters are oriented perpendicular to a side of the

15 side panel.

27. The method of claim 24, further including placing a first bedding system in a substantially horizontal orientation, said first bedding system functioning as a pallet, and placing additional bedding systems in a substantially vertical orientation on top of the first bedding

20 system, thereby forming a block of bedding systems adapted for palletted transport.

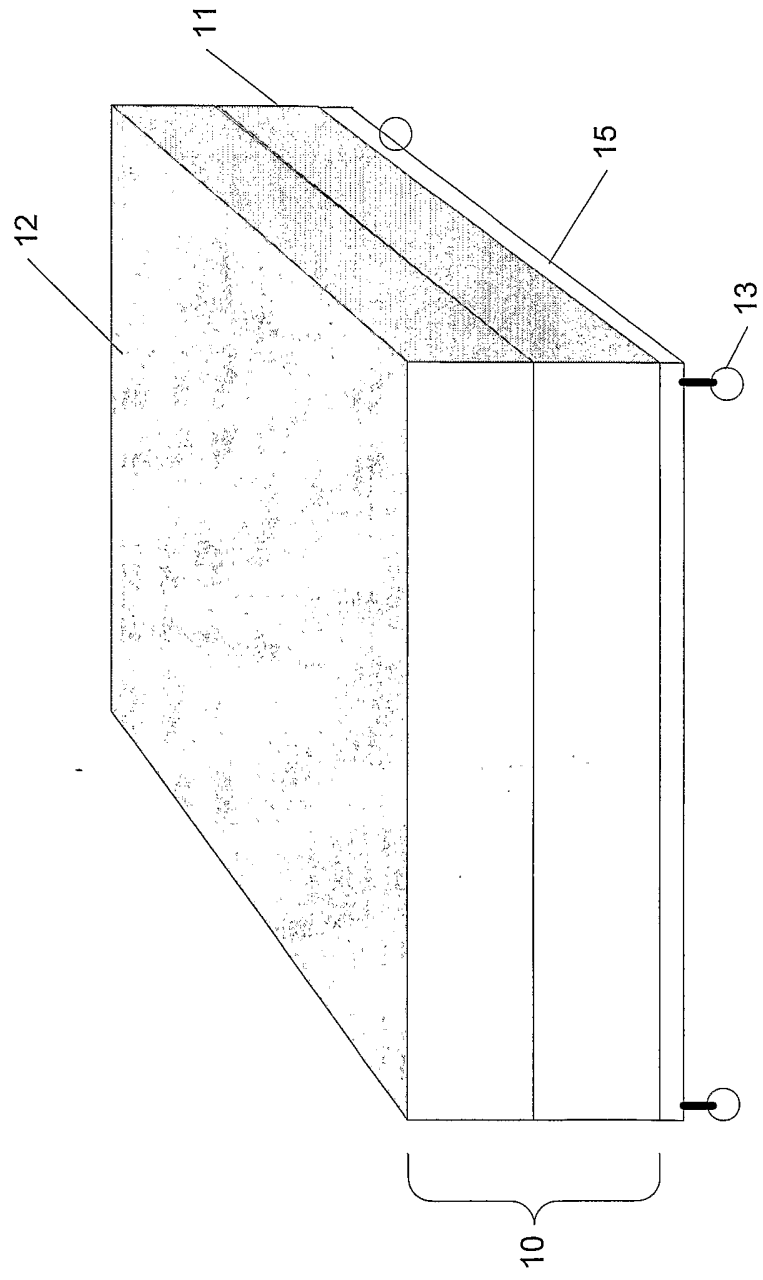

FIG. 1

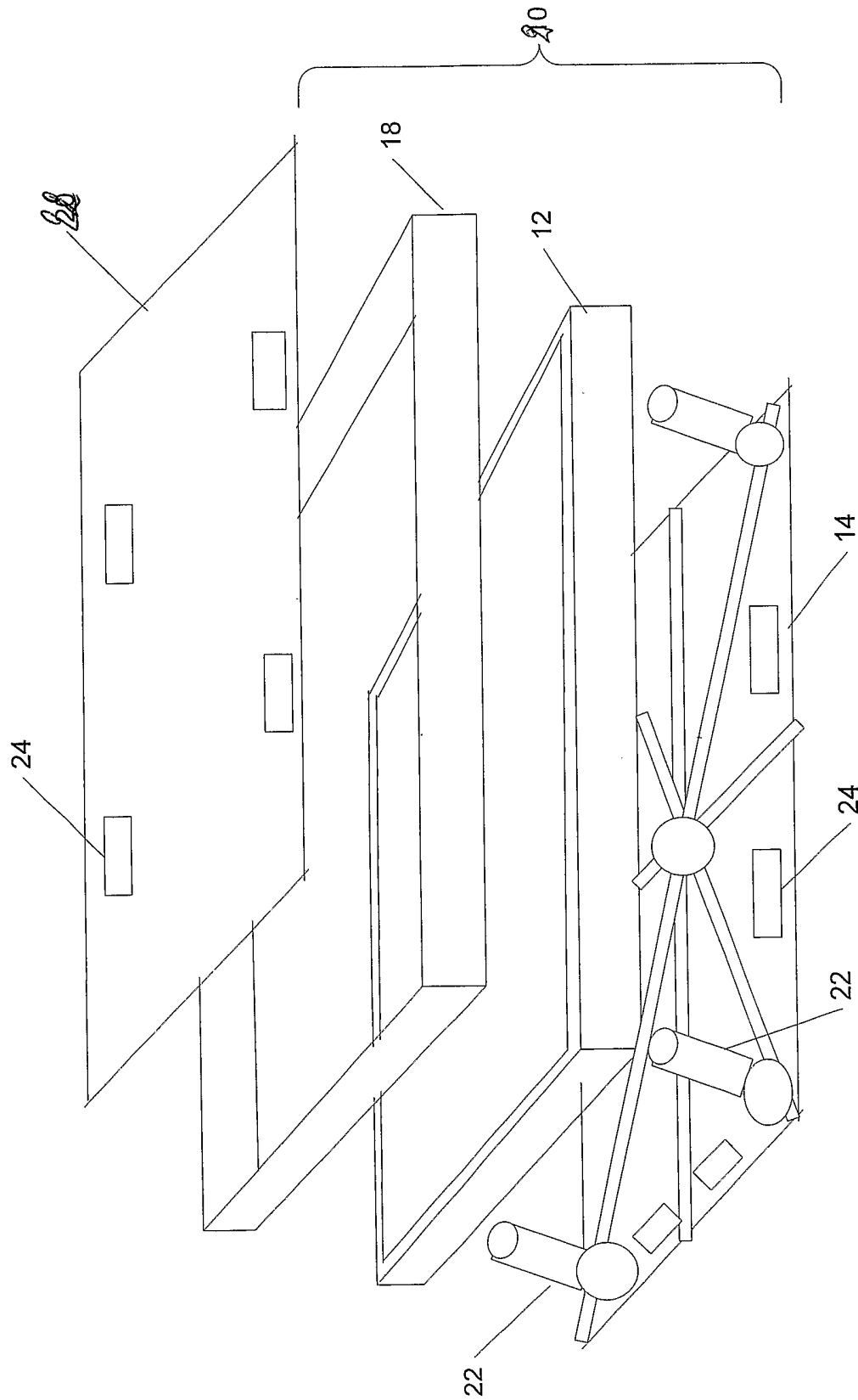

FIG. 2

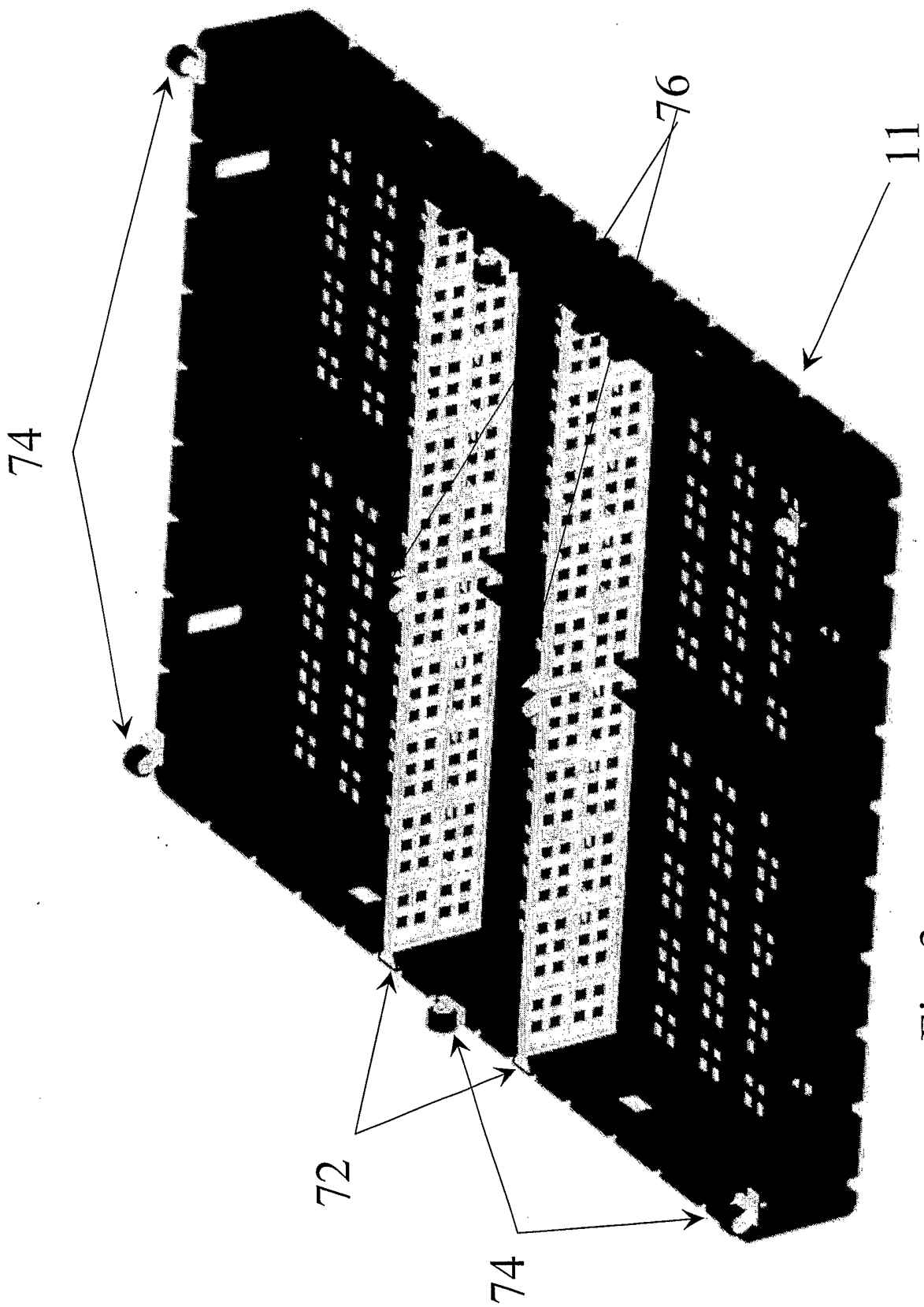

Fig. 3

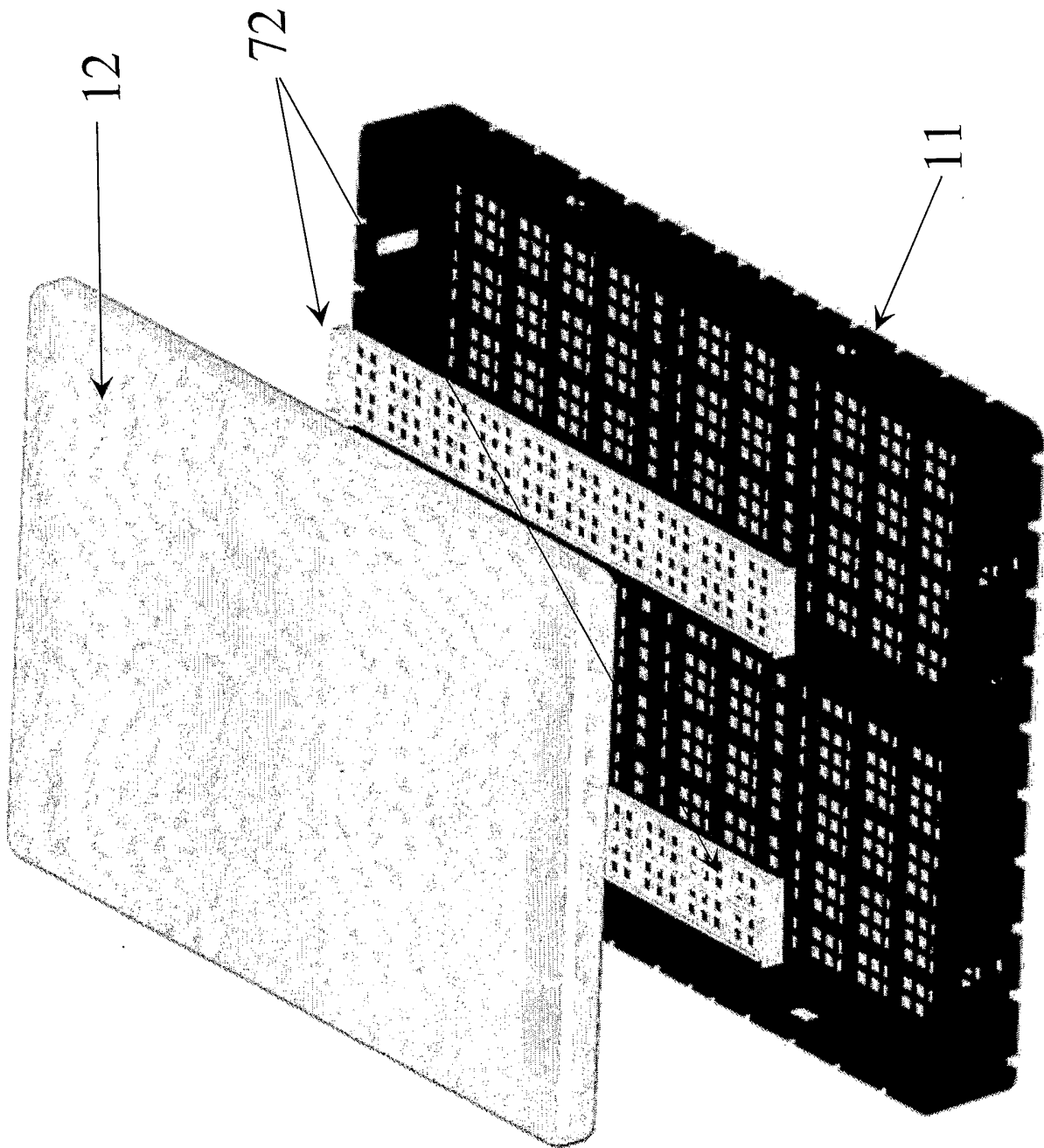

Fig. 4

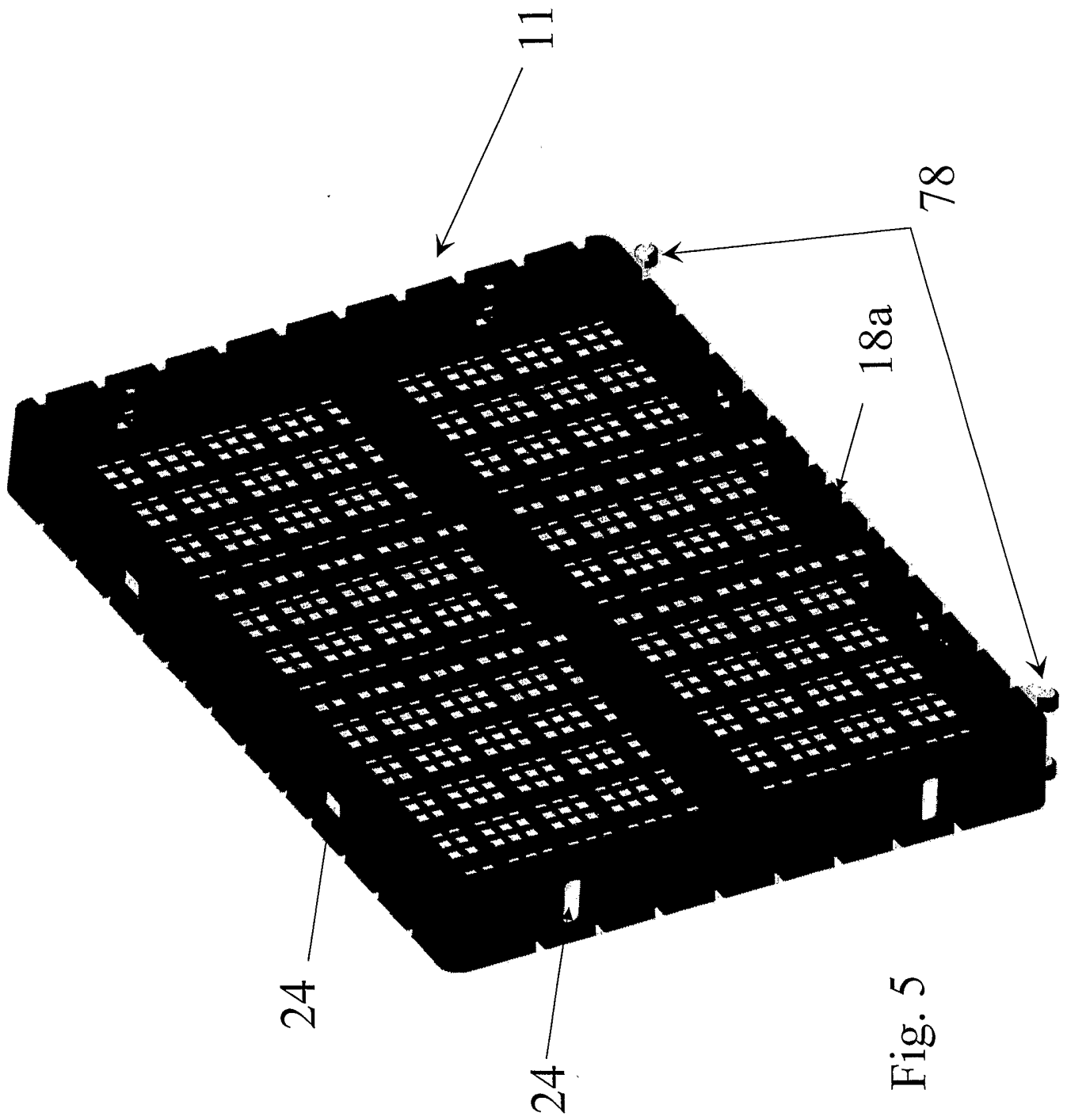

Fig. 5

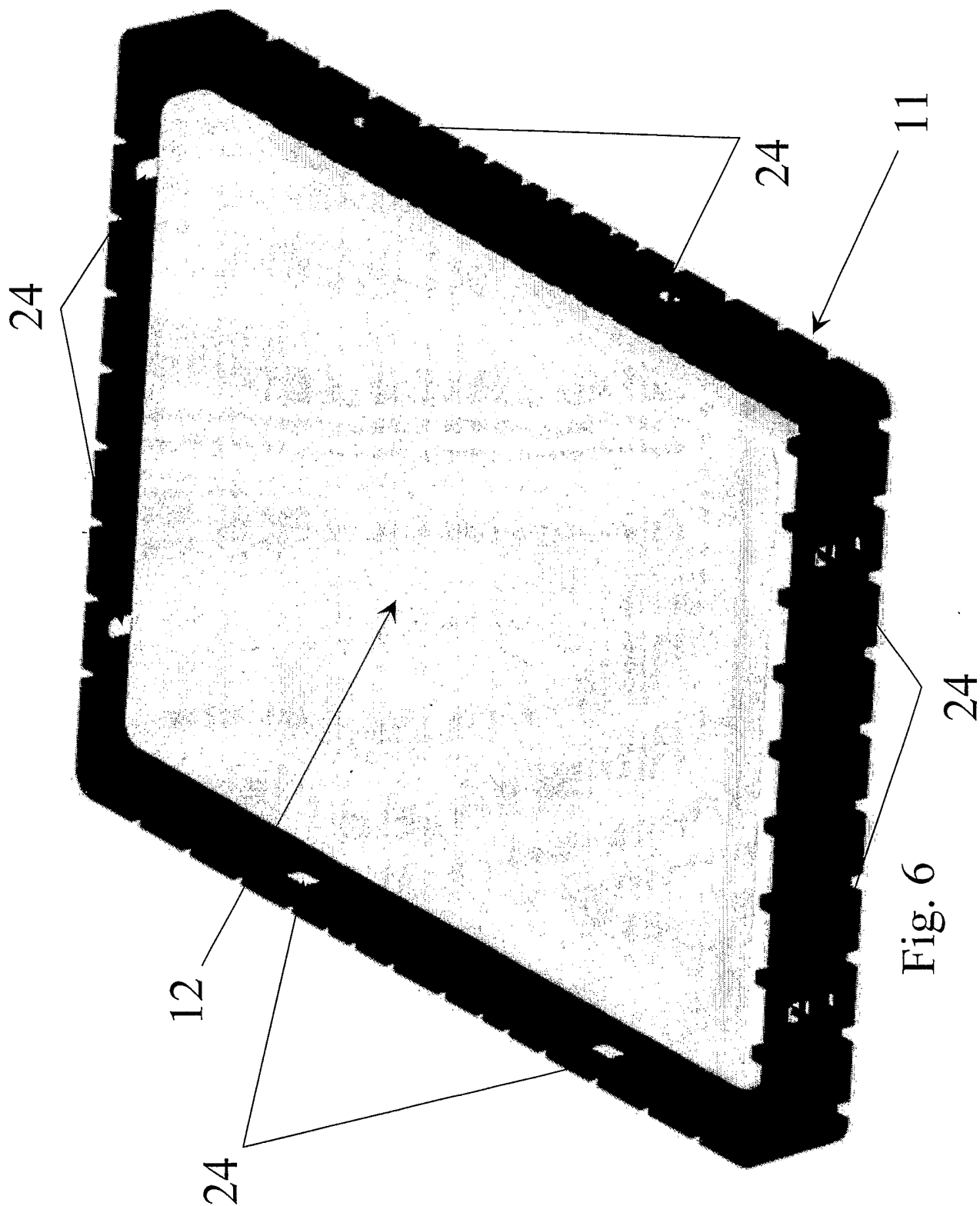

Fig. 6

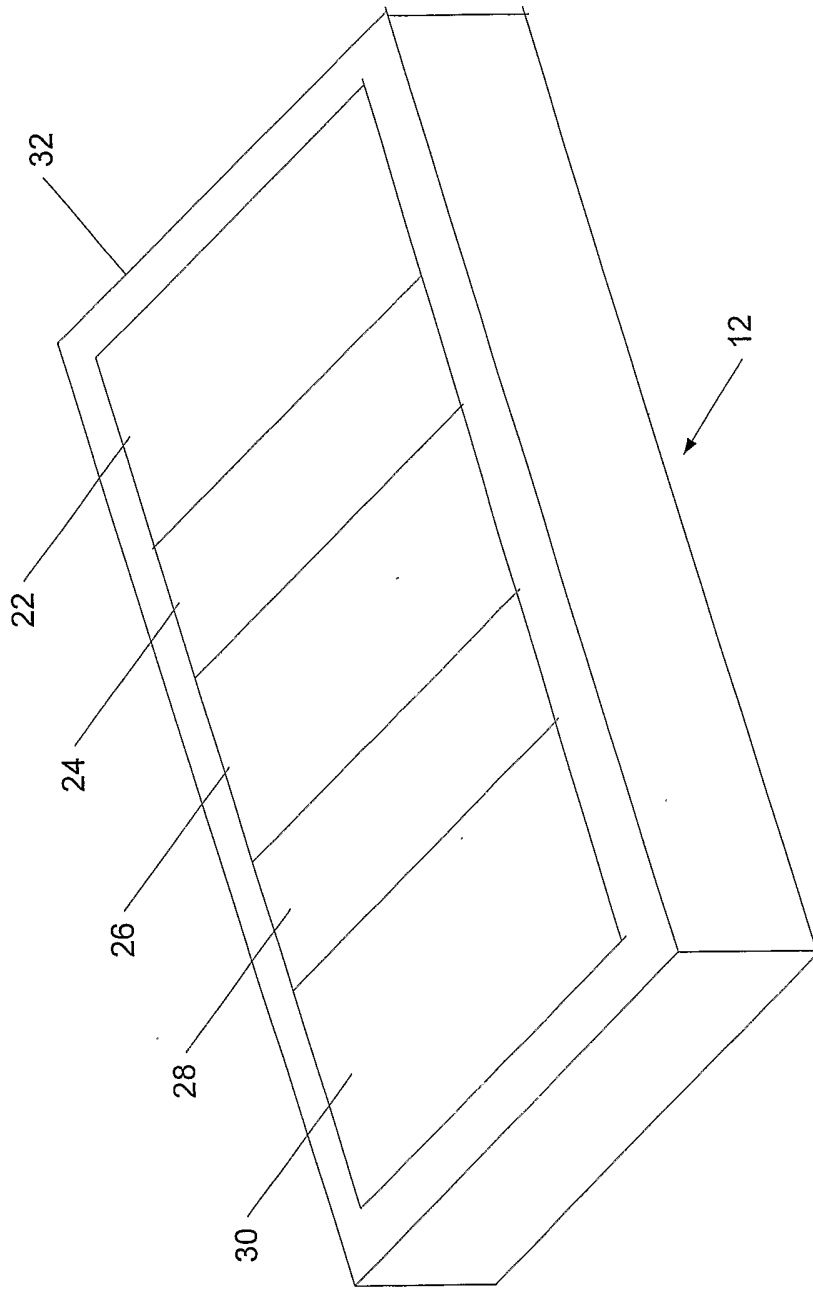

FIG. 7

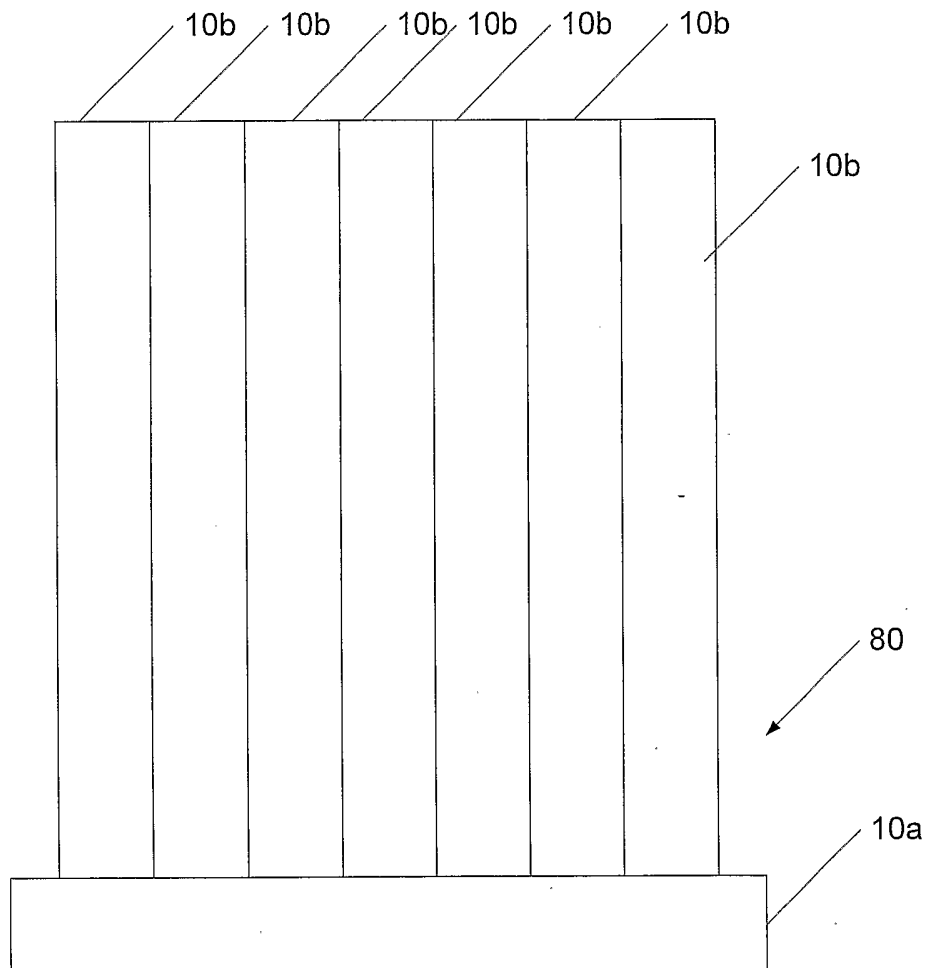

FIG. 8

INTERNATIONAL SEARCH REPORT

International Classification No
PCT/US 03/11597

A. CLASSIFICATION OF SUBJECT MATTER
IPC 7 A47C19/02

According to International Patent Classification (IPC) or to both national classification and IPC

B. FIELDS SEARCHED

Minimum documentation searched (classification system followed by classification symbols)
IPC 7 A47C B65D B65B

Documentation searched other than minimum documentation to the extent that such documents are included in the fields searched

Electronic data base consulted during the international search (name of data base and, where practical, search terms used)

WPI Data, EPO-Internal

C. DOCUMENTS CONSIDERED TO BE RELEVANT

Category °	Citation of document, with indication, where appropriate, of the relevant passages	Relevant to claim No.
Y	US 3 513 490 A (WAGNER WILLIAM T) 26 May 1970 (1970-05-26) column 1, line 15 -column 2, line 41; figures	1-4, 8-16, 18-20, 24-27
X	---	23
Y	FR 2 763 489 A (APTE SA) 27 November 1998 (1998-11-27) abstract	1
Y	US 5 564 140 A (SHOENHAIR JOHN J ET AL) 15 October 1996 (1996-10-15) abstract; figure 1 --- -/--	2,16

Further documents are listed in the continuation of box C.

Patent family members are listed in annex.

° Special categories of cited documents :

- *A* document defining the general state of the art which is not considered to be of particular relevance
- *E* earlier document but published on or after the international filing date
- *L* document which may throw doubts on priority claim(s) or which is cited to establish the publication date of another citation or other special reason (as specified)
- *O* document referring to an oral disclosure, use, exhibition or other means
- *P* document published prior to the international filing date but later than the priority date claimed

- *T* later document published after the international filing date or priority date and not in conflict with the application but cited to understand the principle or theory underlying the invention
- *X* document of particular relevance; the claimed invention cannot be considered novel or cannot be considered to involve an inventive step when the document is taken alone
- *Y* document of particular relevance; the claimed invention cannot be considered to involve an inventive step when the document is combined with one or more other such documents, such combination being obvious to a person skilled in the art.
- *&* document member of the same patent family

Date of the actual completion of the international search

8 July 2003

Date of mailing of the international search report

18/07/2003

Name and mailing address of the ISA

European Patent Office, P.B. 5818 Patentlaan 2
NL - 2280 HV Rijswijk
Tel. (+31-70) 340-2040, Tx. 31 651 epo nl,
Fax: (+31-70) 340-3016

Authorized officer

MacCormick, D

INTERNATIONAL SEARCH REPORT

Internati	lication No
PCT/US	03/11597

C.(Continuation) DOCUMENTS CONSIDERED TO BE RELEVANT

Category °	Citation of document, with indication, where appropriate, of the relevant passages	Relevant to claim No.
Y	US 5 920 930 A (HARROW LAWRENCE) 13 July 1999 (1999-07-13) abstract; figure 1 ---	2
Y	US 5 271 498 A (GILLESPIE ROBERT F) 21 December 1993 (1993-12-21) column 3, line 20 -column 3, line 30; figure 4 ---	27
Y	US 4 870 711 A (FELIX ARTHUR O) 3 October 1989 (1989-10-03) abstract; figure 1 ---	8-13,18, 24-26
Y	US 3 745 596 A (COPELAND M) 17 July 1973 (1973-07-17) abstract; figures ---	8-11,18, 24-26
Y	US 4 646 371 A (NOWELL RICHARD A) 3 March 1987 (1987-03-03) abstract; figures ---	8-11,18, 24-26
Y	US 4 617 689 A (GLOGER KELLY C ET AL) 21 October 1986 (1986-10-21) abstract; figures ---	14,15
Y	US 5 802 646 A (STOLPMANN JAMES R ET AL) 8 September 1998 (1998-09-08) abstract ---	19,20
Y	US 4 928 337 A (CHAUNCEY JEFFREY B) 29 May 1990 (1990-05-29) abstract -----	3,4

INTERNATIONAL SEARCH REPORT

Information on patent family members

Internationa	Application No
PCT/US	03/11597

Patent document cited in search report		Publication date	Patent family member(s)	Publication date
US 3513490	A	26-05-1970	NONE	
FR 2763489	A	27-11-1998	FR 2763489 A1	27-11-1998
US 5564140	A	15-10-1996	NONE	
US 5920930	A	13-07-1999	NONE	
US 5271498	A	21-12-1993	NONE	
US 4870711	A	03-10-1989	NONE	
US 3745596	A	17-07-1973	NONE	
US 4646371	A	03-03-1987	NONE	
US 4617689	A	21-10-1986	AT 50128 T CA 1241801 A1 CA 1251304 A2 DE 3575854 D1 EP 0180099 A2 JP 61159907 A	15-02-1990 13-09-1988 21-03-1989 15-03-1990 07-05-1986 19-07-1986
US 5802646	A	08-09-1998	AU 3210497 A BR 9709114 A CA 2255616 A1 EP 0955848 A1 JP 2000511086 T WO 9743927 A1 US RE38135 E1	09-12-1997 03-08-1999 27-11-1997 17-11-1999 29-08-2000 27-11-1997 10-06-2003
US 4928337	A	29-05-1990	NONE	