

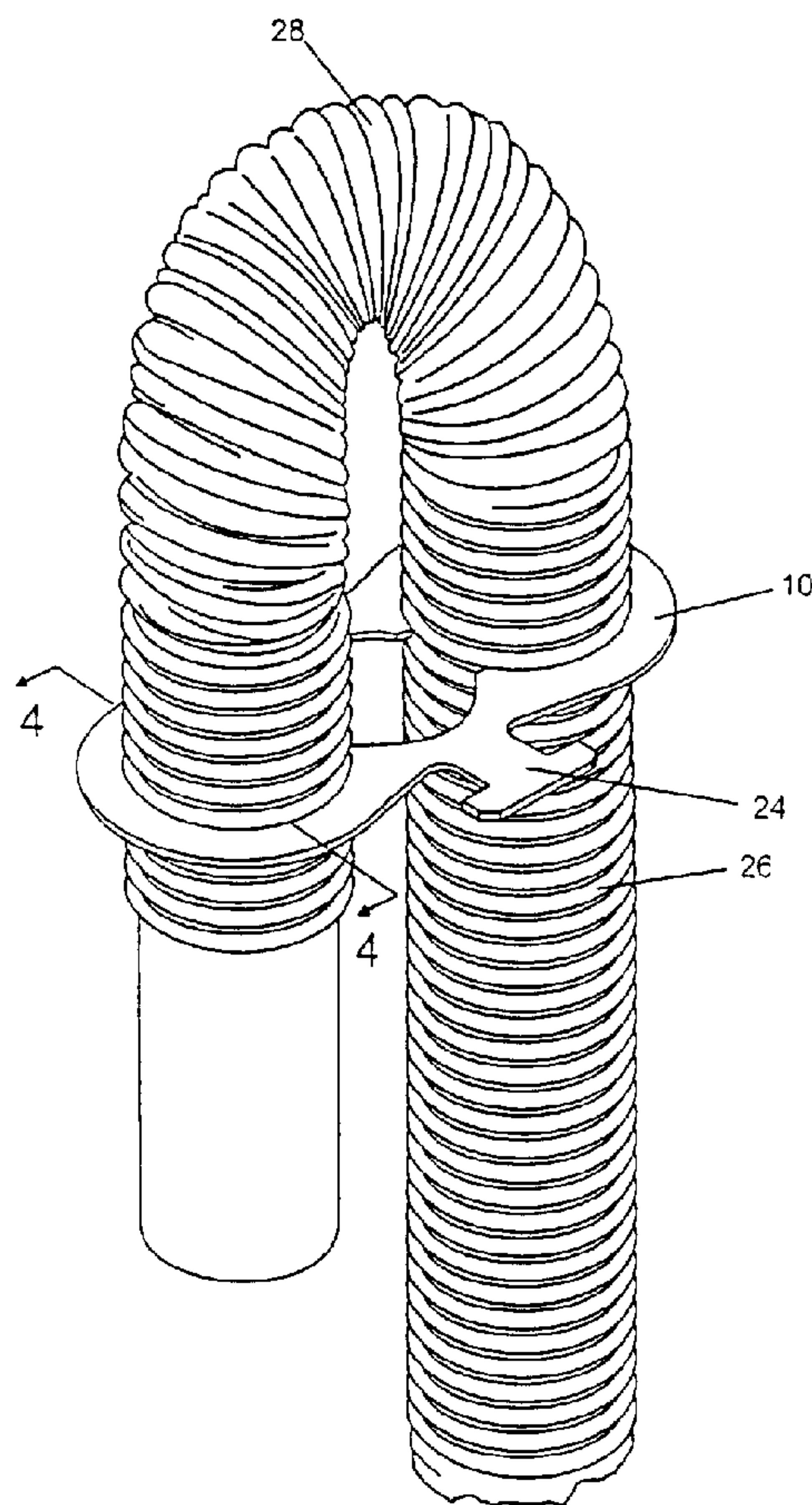

(72) HERR, JOEL L., US
(72) JOHNSON, TROY A., US
(72) JACKOVIN, GARY B., US
(71) MAYTAG CORPORATION, US
(51) Int.Cl.⁷ F16L 3/02, D06F 39/08
(30) 1999/07/30 (09/364,561) US
(54) **DISPOSITIF DE RETENUE DE TUYAU SOUPLE**
(54) **HOSE RETAINER**



(57) A hose retainer is provided to maintain a hose in a gooseneck shape. The retainer includes opposite rings which retentively engage portions of the hose adjacent the gooseneck. The retainer is molded or stamped from plastic so as to have a flat one-piece construction. A tab is provided on the retainer and is adapted to be received in a slot on the back of a washing machine to hold the hose close to the machine during shipping and storage.

HOSE RETAINERABSTRACT OF THE DISCLOSURE

5 A hose retainer is provided to maintain a hose in
a gooseneck shape. The retainer includes opposite
rings which retentively engage portions of the hose
adjacent the gooseneck. The retainer is molded or
stamped from plastic so as to have a flat one-piece
construction. A tab is provided on the retainer and is
adapted to be received in a slot on the back of a
washing machine to hold the hose close to the machine
10 during shipping and storage.

HOSE RETAINERBACKGROUND OF THE INVENTIONField of the Invention

5 All washing machines include a drain hose, which
drains water from the tub. In residential machines,
the drain hose typically discharges into a standpipe
behind the washing machine. The end of the hose is
formed into a U-shape or gooseneck, with the inside
crest of the gooseneck resting in the end of the
10 standpipe. The goose neck shape can be preformed into
the hose or maintained by a retainer.

Prior art hose retainers have been made from wire
or plastic. The prior art retainers are bent or formed
into curves to form the hose into the gooseneck shape.
15 Multiple piece retainers are disclosed in U.S. Patents
2,786,483, 4,151,864 and 4,318,519. A one-piece wire
hose retainer is disclosed in U.S. Patent 4,163,457.

The shapes and construction of the prior art
retainers increases the manufacturing costs, as well as
20 the assembly time in forming the hose into the goose
neck shape. For example, in each of the above-cited
prior art patents, the hose must be threaded through
the rings at each end of the retainer.

Accordingly, a primary objective of the present
25 invention is the provision of an improved retainer for
the hose of a washing machine.

Another objective of the present invention is a
provision of a hose retainer that is stamped or molded
from plastic.

30 A further objective of the present invention is a
provision of a hose retainer that has a one-piece
construction;

Another objective of the present invention is a
provision of a hose retainer which can be quickly and

easily installed on the hose to form the hose into a gooseneck shape.

Another objective of the present invention is the provision of a hose retainer that is economical to manufacture and durable in use.

These and other objectives become apparent from the following description of the invention.

SUMMARY OF THE INVENTION

The hose retainer of the present invention is a flat plastic member having a pair of rings or openings for retentively engaging two portions of a hose so as to form the hose into a gooseneck between the two retained portions. The rings are spaced apart by a web extending therebetween. In one embodiment, the web includes an opening such that the hose retainer can slide over the curved gooseneck, thereby eliminating the step of separately threading the end of the hose through each retainer. In another embodiment, the rings are in the form of clips with open sides for receiving the respective hose portions. A tab is provided on the retainer and is adapted to be received within a slot on the back wall of the washing machine so as to support the hose adjacent the back wall for shipping and storage. The hose retainer of the present invention is particularly adapted for use with the drainage of a washing machine, but can also be used on other hoses so as to form a gooseneck adjacent the end of the hose.

BRIEF DESCRIPTION OF THE DRAWINGS

Figure 1 is a perspective view of a first embodiment of the hose retainer of the present invention positioned on a hose to form a gooseneck in the hose.

Figure 2 is a perspective view of the retainer.

Figure 3 is a plan view of the retainer.

Figure 4 is a sectional view taken along lines 4-4 of Figure 1.

5 Figure 5 is a view of the back wall of a washing machine with the retainer clip of the present invention secured thereto.

Figure 6 is a plan view of a second embodiment of the hose retainer of the present invention.

10 Figure 7 is a sectional view taken along lines 7-7 of Figure 6 with the hose positioned in the retainer.

Figure 8 is a plan view of a third embodiment of the present invention.

15 Figure 9 is a sectional view showing the third embodiment in position on a hose.

DETAILED DESCRIPTION OF THE INVENTION

A hose retainer according to the present invention is generally designated by the reference numeral 10 in Figures 1-5. The retainer 10 is a thin flat plastic member, which may be molded or stamped so as to have a one-piece construction. The retainer 10 includes first and second openings 12, 14 formed therein so as to define first and second rings 16, 18 respectively. A web 20 extends between the rings 16, 18. The web includes a hole 22 intersecting the first and second openings 12, 14, such that the first and second rings 16, 18 are C-shaped with the open sides of the C's facing towards one another. A tab 24 extends from the web 20.

30 In use, a hose 26, such as a washing machine drain hose, is formed into a gooseneck or U-shape 28. The retainer 10 fits over the curved gooseneck 28 of the hose 26 such that the rings 16, 18 substantially encircle respective portions of the hose, thereby

retaining the hose 26 in the gooseneck 28.

Alternatively, the end of the hose 26 can be extended through the openings 12, 14 so as to position the retainer 10 on the hose. The retainer 10 is
5 sufficiently thin so as to be received through adjacent corrugations on the hose, as shown in Figure 4.

The back wall 30 of the washing machine 32 includes a slot 34. The tab 24 is adapted to fit within the slot 34, thereby holding the hose adjacent
10 to the back wall 30 of the washing machine 32, as shown in Figure 5, during shipping and storage. Preferably, the slot 34 is T-shaped, so the tab 24 can fit into the head of the T and then slide downwardly for retention in the leg of the T.

15 A second embodiment of the hose retainer is designated by the reference numeral 40 in Figures 6 and 7. The retainer 40 has a one-piece construction and is made from stamped or molded plastic. The retainer 40 includes opposite C-shaped rings or clips 42, 44. The
20 open ends 46, 48 of the rings 42, 44 face away from one another. A web 50 extends between the rings 42, 44. A tab 52 extends from the web 50 for receipt in the slot 34 on the back wall 30 of the washing machine 32, as described above with respect to the first embodiment
25 hose retainer 10. The inner perimeter of the rings 42, 44 includes a reduced-diameter ridge 54. Ridge 54 is sized so as to be received within a groove between corrugations in a corrugated hose 56. The rings 42, 44 are snap fit around the resilient hose portions as the
30 hose is formed into the gooseneck. The end of the hose 66 does not have to be separately threaded through each of the rings 42, 44.

A third embodiment of a hose retainer according to the present invention is generally designated in
35 Figures 8 and 9 by the reference numeral 60. The

retainer 60 is a flat one-piece construction made from stamped or molded plastic. The retainer 60 includes rings 62, 68 adapted to engage portions of the hose 66 so as to maintain the hose 66 in a gooseneck configuration. To assemble, the end of the hose 66 is first threaded through the ring 62. The retainer 60 further includes a tab end 70 having side portions 64 which is then folded over within the gooseneck of the hose 66 and then the hose 66 is threaded through ring 68. The tab end 70 prevents the hose 66 from being accidentally removed from the retainer 60. Thus, the tab end 70 inhibits removal of the retainer 60 from the hose 66. A tab 72 is provided on the retainer 60 for receipt in the slot 34 on the back wall 30 of the washing machine 32, as described above with respect to the hose retainer 10. If desired, one of the side portions 64 may be interrupted which will allow the retainer 60 to be attached to the hose 66 in a manner similar to that of the first embodiment 10. The tab end 70 can then be inserted within the gooseneck of the hose 66.

It is understood that the retainers of the present invention can be used on corrugated hose, as shown in the drawings, or on non-corrugated hose.

The preferred embodiment of the present invention has been set forth in the drawings, specification, and although specific terms are employed, these are used in a generic or descriptive sense only and are not used for purposes of limitation. Changes in the form and proportion of parts as well as in the substitution of equivalents are contemplated as circumstances may suggest or render expedient without departing from the spirit and scope of the invention as further defined in the following claims.

The embodiments of the invention in which an exclusive property or privilege is claimed are defined as follows:

1. A hose retainer, comprising:
a substantially flat member having a first opening for receiving a portion of a hose and a second opening for receiving a second portion of the hose such
5 that the member holds the hose in a U-shape between the first and second openings.
2. The hose retainer of claim 1 further comprising a web extending between the first and second openings.
3. The hose retainer of claim 1 further comprising a tab on the flat member for attaching the member for attaching the member to a support structure.
4. The hose retainer of claim 1 wherein the flat member is elongated and the openings are formed at opposite ends.
5. The hose retainer of claim 1 wherein the openings include a ridge for engaging a groove between corrugations in the hose.
6. The hose retainer of claim 1 wherein the member is a molded plastic piece.
7. The hose retainer of claim 1 wherein the member is a stamped plastic piece.
8. A hose retainer, comprising:
a first ring adapted to receive a first portion of a hose;

5 a second ring adapted to receive a second portion of a
hose;
a web connecting the first and second rings; and
the rings and web having a one-piece plastic
construction.

9. The hose retainer of claim 8 further comprising a
tab for attaching the retainer to a support structure.

10. The hose retainer of claim 8 further comprising a
tab for attaching the retainer to a support structure.

11. The hose retainer of claim 8 wherein the rings are
C-shaped.

12. The hose retainer of claim 8 wherein the rings
each have an open side, the open sides facing toward
one another.

13. The hose retainer of claim 8 wherein the rings
each have an open side, the open sides facing away from
one another.

14. In combination with a washing machine with a
discharge hose operatively connected thereto, a hose
retainer, comprising:
5 a flat plastic member having a pair of rings adapted to
retain two portions of the hose to form a
gooseneck therebetween.

15. The combination of claim 14 wherein the hose
retainer further includes a web extending between the
rings so as to space the rings apart.

16. The combination of claim 15 wherein the rings and the web have a one-piece construction.

17. The combination of claim 14 wherein the washing machine includes a wall with a slot, and the hose retainer includes a tab adapted to be received in the slot to support the hose adjacent the wall.

18. The combination of claim 14 wherein the hose is corrugated, and wherein the rings are thin so as to fit in grooves between corrugations.

19. The combination of claim 14 wherein the web includes an opening such that the retainer is adapted to slide downwardly over the gooseneck without threading the hose separately through the rings.

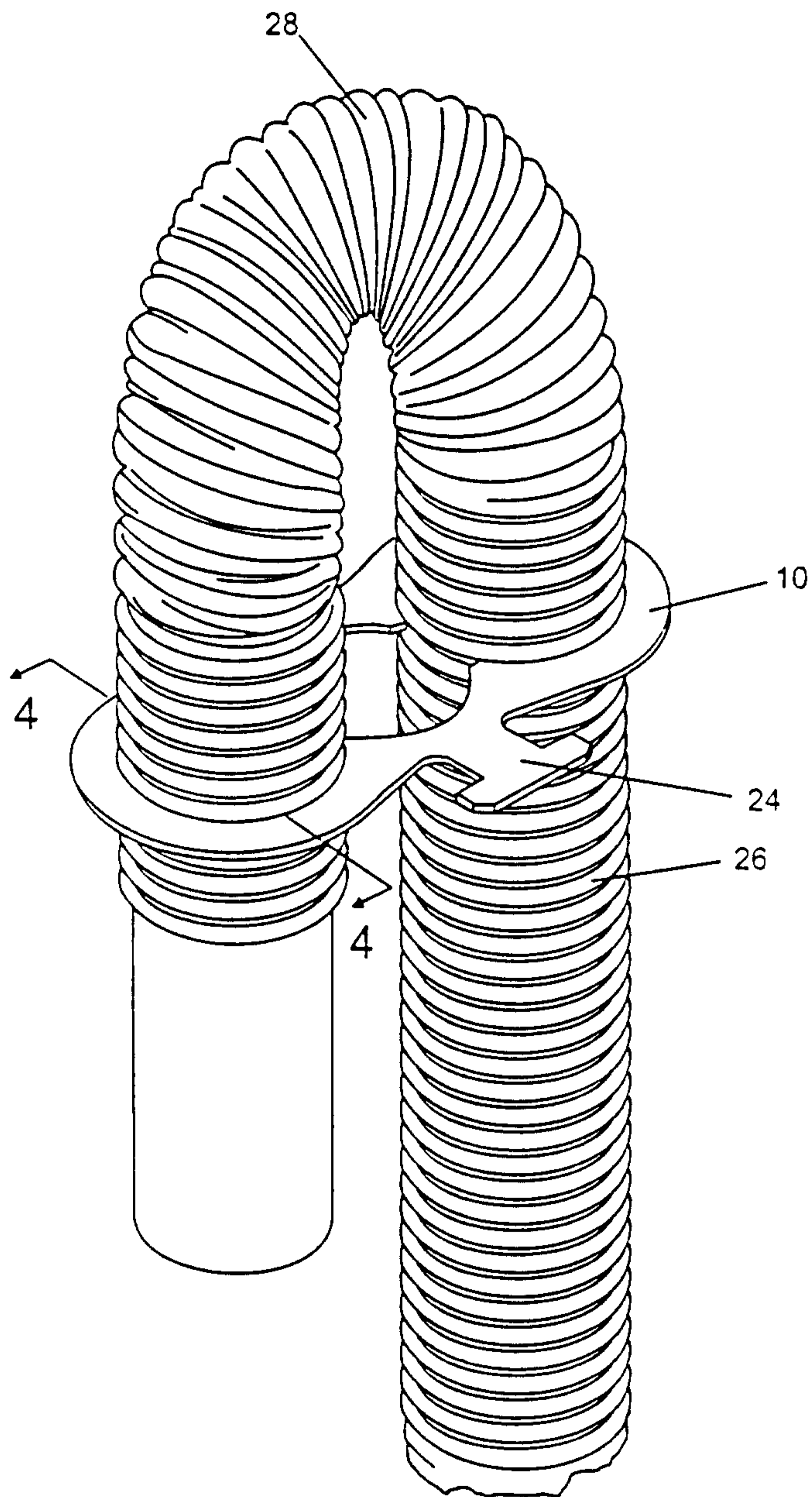
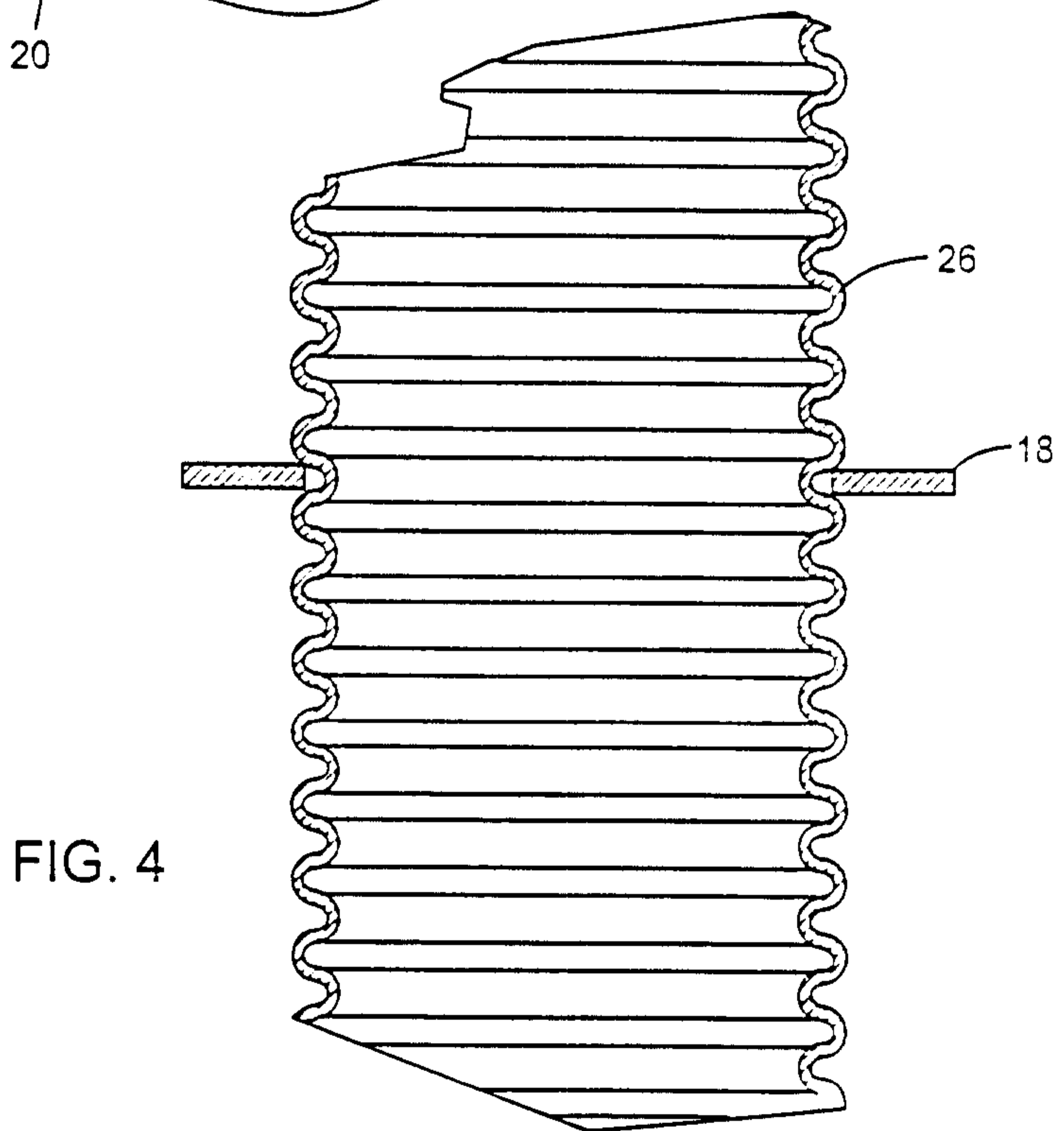
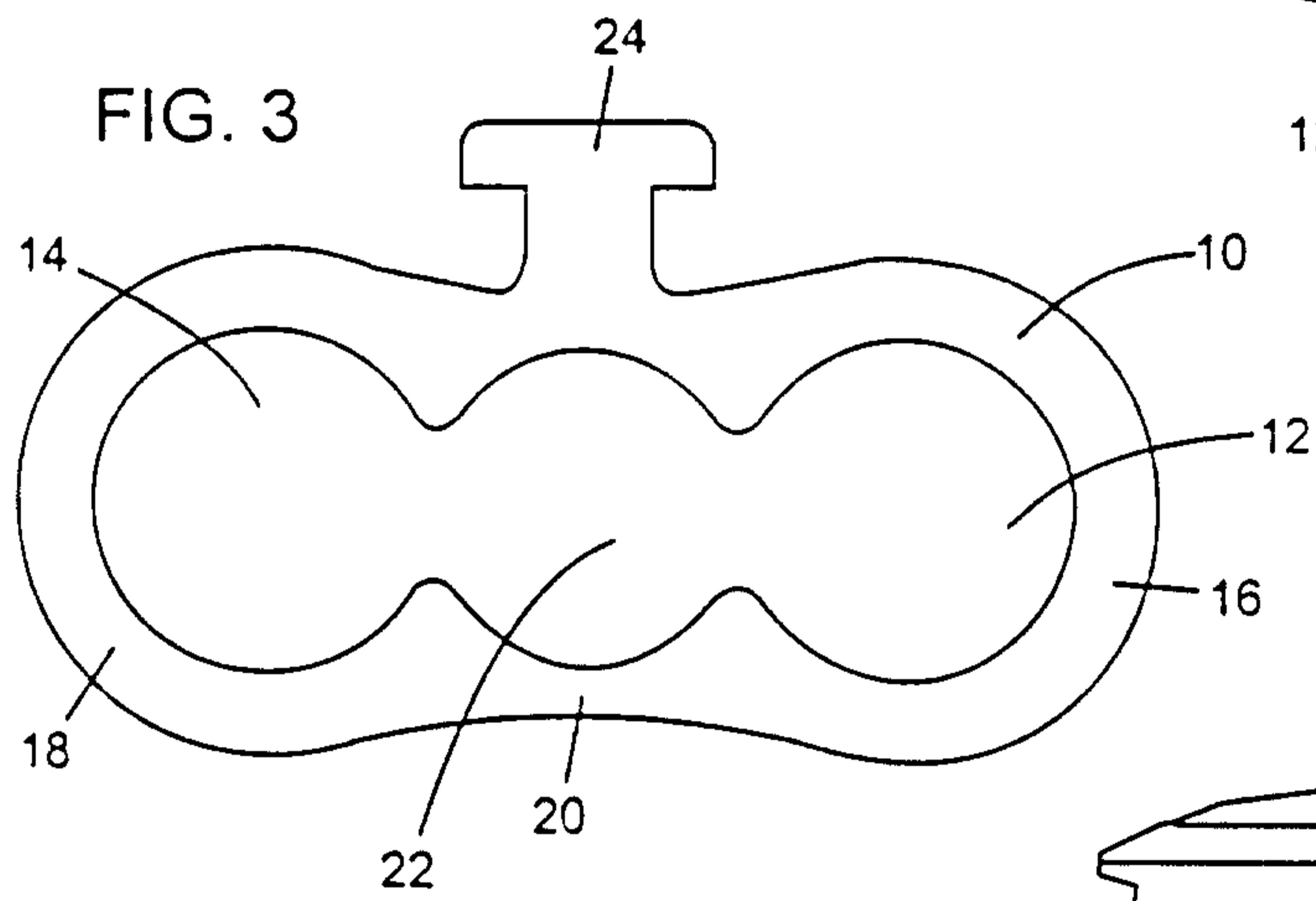
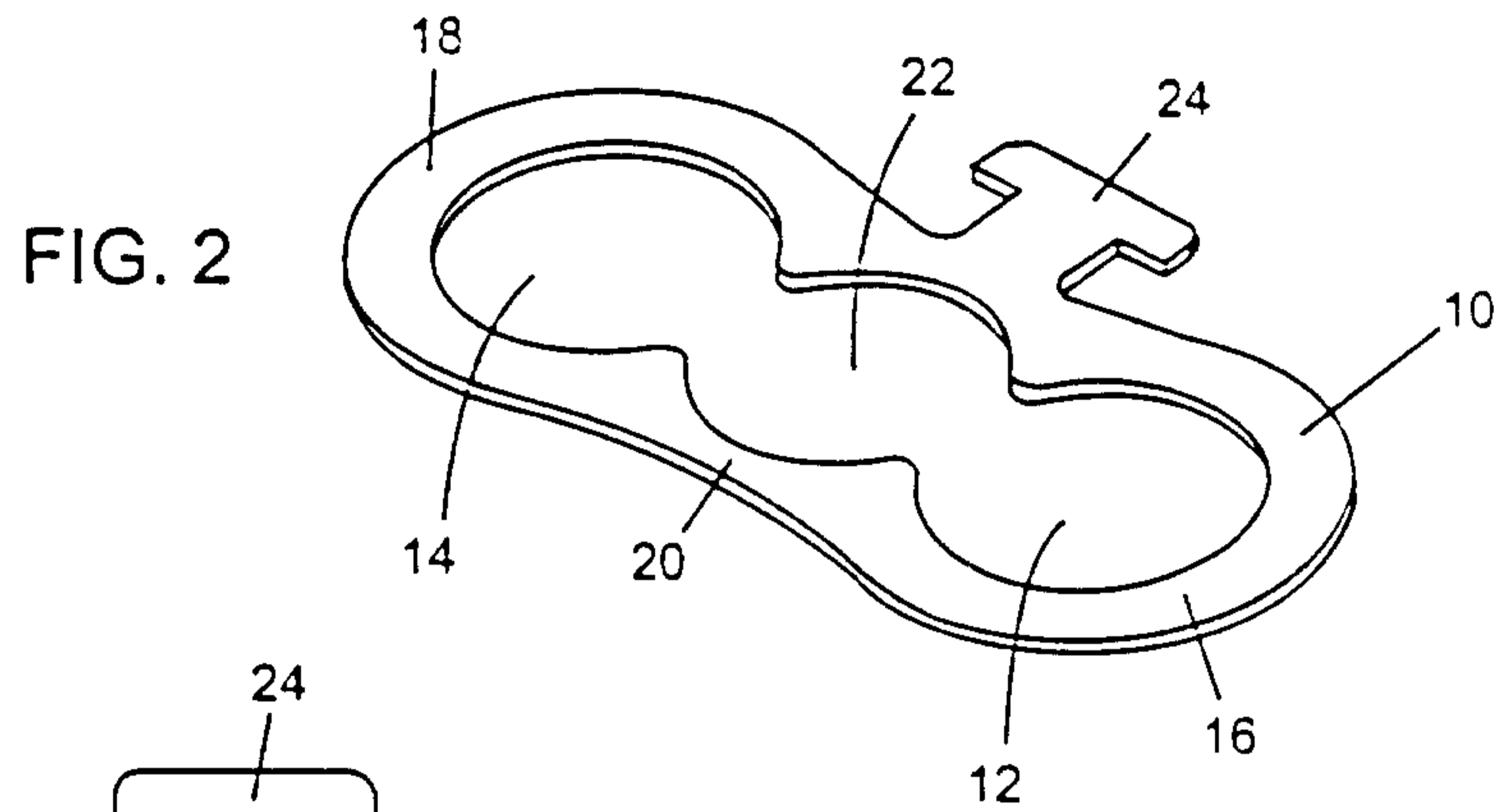
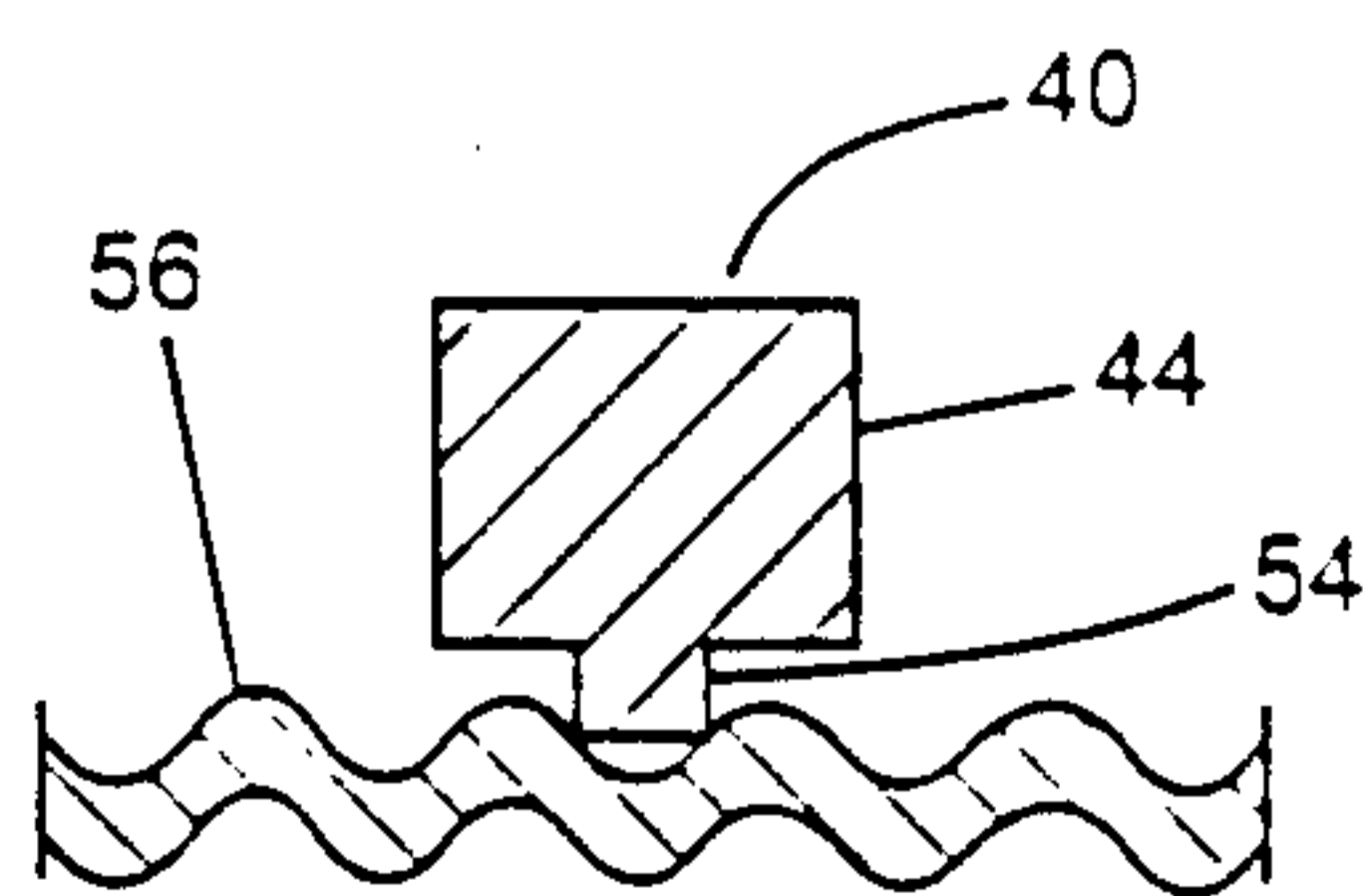
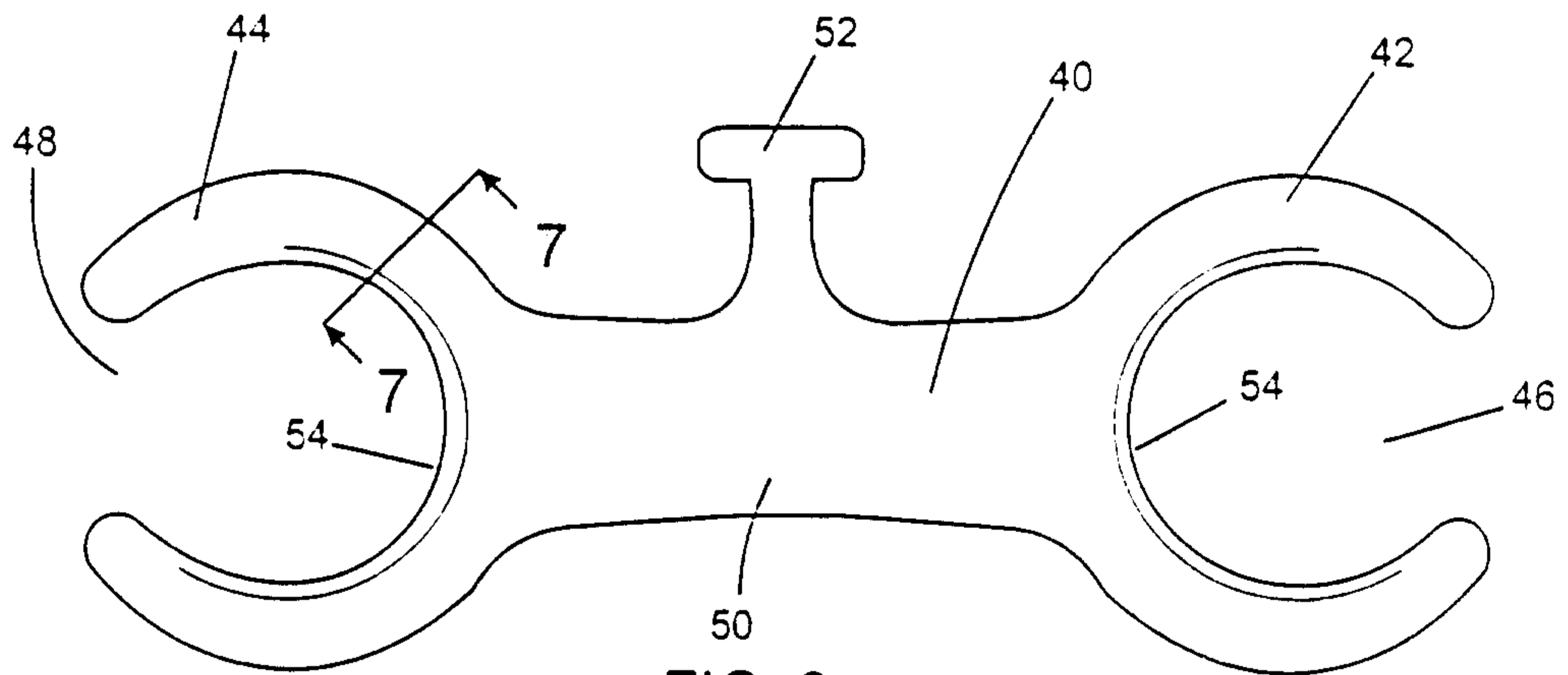
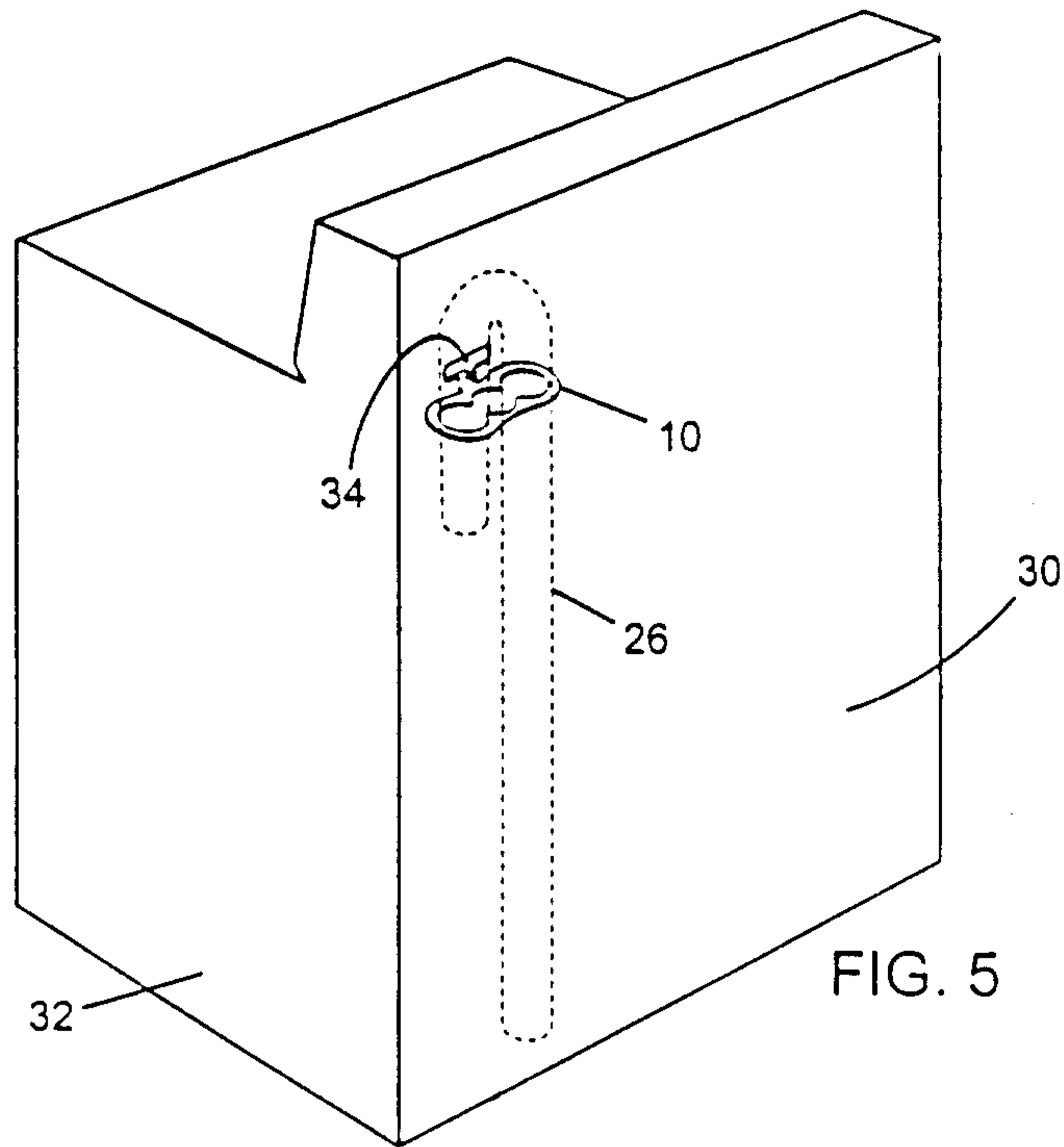

FIG. 1





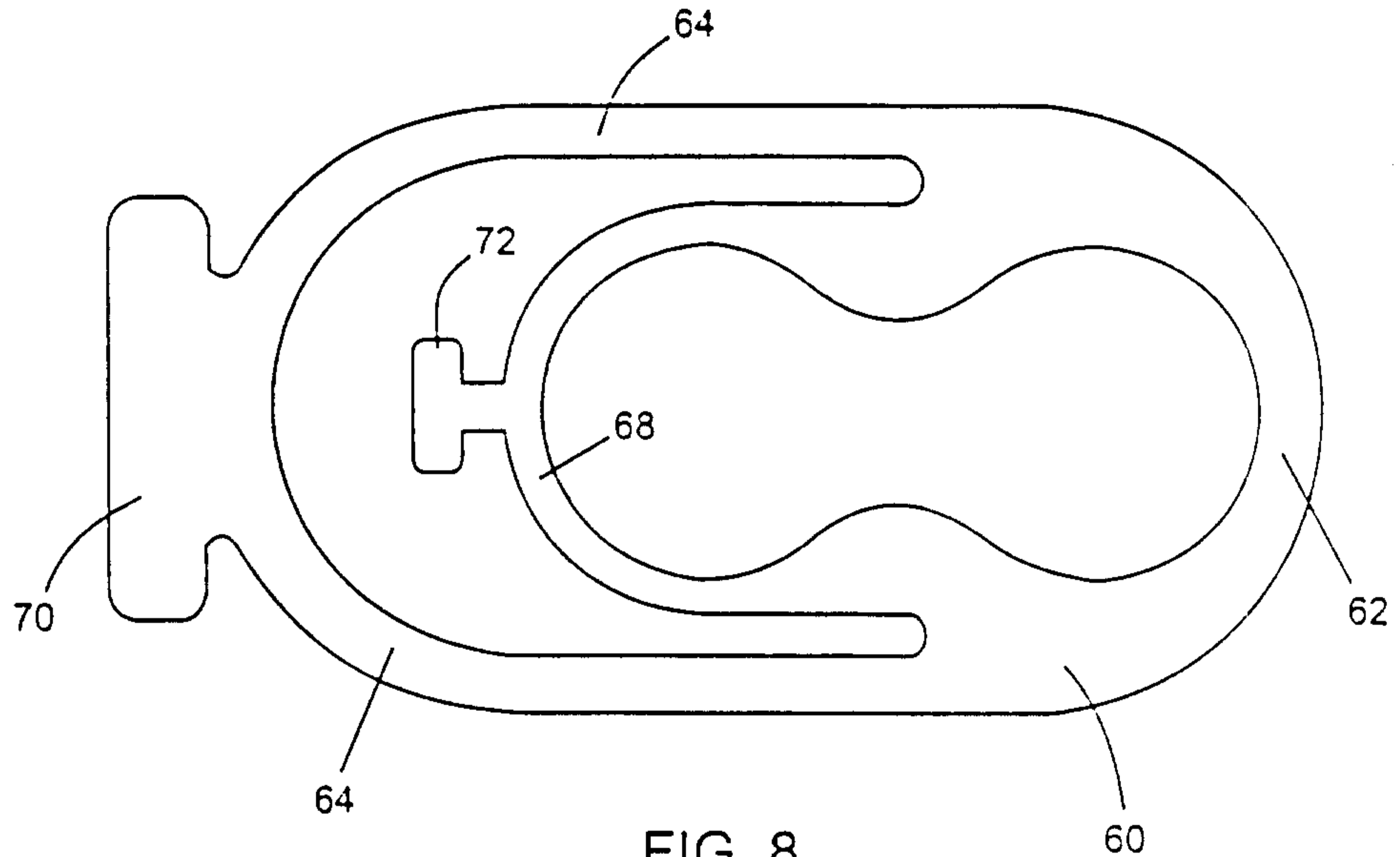

FIG. 9

