



(72) MARUTA, YASUSHI, JP
(72) YOSHIDA, SHOUSEI, JP
(71) NEC CORPORATION, JP

(51) Int.Cl.⁶ H01Q 21/29

(30) 1998/09/03 (250064/1998) JP

(54) **APPAREIL DE RECEPTION A ANTENNE RESEAU**

(54) **ARRAY ANTENNA RECEPTION APPARATUS**

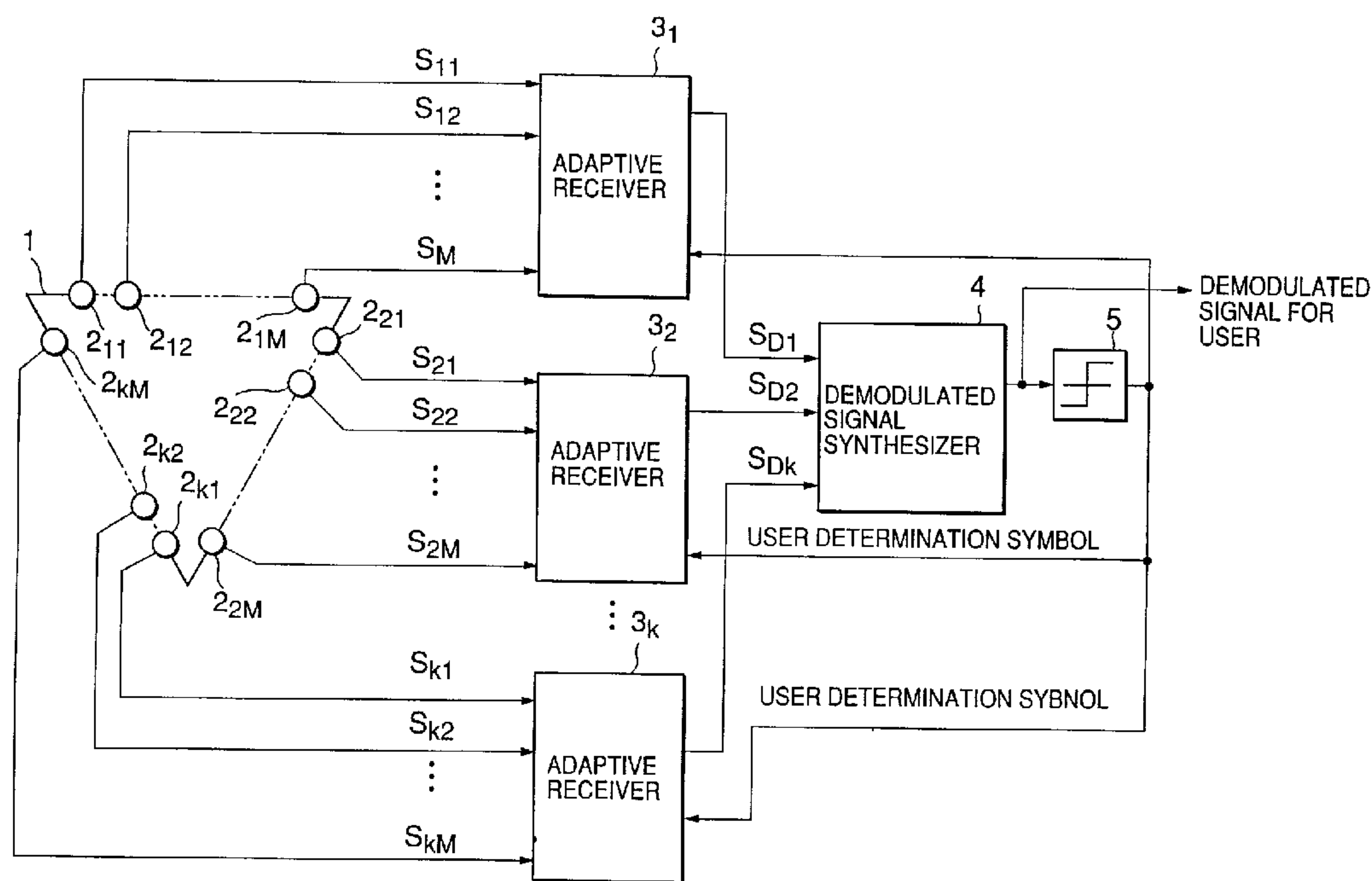

(57) An array antenna reception apparatus includes an array antenna, K adaptive receivers, and demodulated signal synthesizer. The array antenna has M (M is an integer of 1 or more) antenna elements linearly laid out on each side (sector) of a polygon having K (K is an integer of 3 or more) sides. Each adaptive receiver receives reception signals from the M antenna elements for a corresponding sector, independently forms a directional pattern having a gain in a desired signal direction for the sector, receives a desired signal, and suppresses an interference signal. The demodulated signal synthesizer receives K demodulated signals as outputs from the K adaptive receivers, weights and synthesizes the signals, and outputs a demodulated signal for a user.



ABSTRACT OF THE DISCLOSURE

An array antenna reception apparatus includes an array antenna, K adaptive receivers, and demodulated
5 signal synthesizer. The array antenna has M (M is an integer of 1 or more) antenna elements linearly laid out on each side (sector) of a polygon having K (K is an integer of 3 or more) sides. Each adaptive receiver receives reception signals from the M antenna elements for
10 a corresponding sector, independently forms a directional pattern having a gain in a desired signal direction for the sector, receives a desired signal, and suppresses an interference signal. The demodulated signal synthesizer receives K demodulated signals as outputs from the K
15 adaptive receivers, weights and synthesizes the signals, and outputs a demodulated signal for a user.

ARRAY ANTENNA RECEPTION APPARATUS

BACKGROUND OF THE INVENTION

FIELD OF THE INVENTION

5 The present invention relates to an array antenna
reception apparatus installed in a base station for
removing another user interference under antenna
directivity control and, more particularly, to an array
antenna having antenna elements linearly laid out on each
10 side of a polygon.

DESCRIPTION OF THE PRIOR ART

In a cellular mobile communication system and the
like, the following method is examined. A directional
pattern which maximizes the reception gain in a desired
15 signal arrival direction is formed using an adaptive
antenna made up of a plurality of antenna elements, and
interference from another user and interference by a
delayed wave are removed in reception. As a radio
transmission method expected for a large subscriber
20 capacity, the CDMA method receives a great deal of
attention.

Fig. 1 is a block diagram showing an example of a
conventional array antenna reception apparatus using the
CDMA method.

25 The conventional array antenna reception apparatus is

- 2 -

constituted by an antenna 20 having a plurality of antenna elements 21_1 to 21_M laid out circularly, one adaptive receiver 22, and a determination circuit 5.

The antenna 20 is made up of the M antenna elements
5 21_1 to 21_M laid out circularly. Each of the antenna elements 21_1 to 21_M is not particularly limited in horizontal plane directivity and may take omnidirectivity or dipole directivity. The M antenna elements 21_1 to 21_M are close to each other so as to establish correlations
10 between antenna reception signals, and receive signals obtained by code-multiplexing a desired signal and a plurality of interference signals. In the following processing, since signals are digitally processed in the baseband, M antenna reception signals S_1 to S_M are
15 frequency-converted from the radio band to the baseband and A/D-converted.

The determination circuit 5 receives a demodulated signal for a user as an output from the adaptive receiver 22 and performs hard determination for the demodulated
20 signal, thereby outputting a user determination symbol. Here, it should be noted that only one of the determination circuit 5 is shown in Fig. 1, but other circuits are omitted.

Fig. 2 is a block diagram showing the adaptive
25 receiver 22 in the conventional array antenna reception

apparatus.

The adaptive receiver 22 is constituted by despread circuits 6_1 to 6_M , weighting synthesizer 7, demodulator 10, complex multiplier 13, subtracter 14, delay circuit 15, and antenna weight control circuit 16. The adaptive receiver 22 receives the antenna reception signals S_1 to S_M received by the M antenna elements 21_1 to 21_M laid out circularly, and the user determination symbol as an output from the determination circuit 5, and outputs a demodulated signal for a user.

The despread circuits 6_1 to 6_M calculate correlations between the antenna reception signals S_1 to S_M and a user spread code C . Assuming that the spread code C is a complex code made up of two quadrature codes C_I and C_Q , the despread circuits 6_1 to 6_M can be realized by one complex multiplier and averaging circuits over the symbol section. The despread circuits 6_1 to 6_M can also be realized by a transversal filter arrangement with a tap weight C .

The weighting synthesizer 7 comprises complex multipliers 8_1 to 8_M and adder 9. The weighting synthesizer 7 multiplies outputs from the despread circuits 6_1 to 6_M by antenna weights W_{r1} to W_{rM} , and adds them to generate a signal received with a directional pattern unique to a desired signal.

The demodulator 10 comprises a transmission path

estimation circuit 11 and complex multiplier 12. The product of an output from the weighting synthesizer 7 and the complex conjugate of a transmission path estimation output is the demodulated signal for a user as an output
5 from the adaptive receiver 22.

The complex multiplier 13 multiplies the user determination symbol by the transmission path estimation output. In multiplying the user determination symbol by the transmission path estimation output, only a component
10 about the phase of the estimation value can be multiplied, and an amplitude obtained by another means can be multiplied. This another means is one for obtaining the amplitude by measuring reception power or the like.

The subtracter 14 calculates the difference between
15 an output from the complex multiplier 13 and an output from the weighting synthesizer 7, and detects an antenna weight control error e .

The delay circuit 15 delays outputs from the despread circuits 6_1 to 6_M in accordance with the processing times
20 of the weighting synthesizer 7, demodulator 10, subtracter 14, and the like.

The antenna weight control circuit 16 calculates the antenna weights W_{r1} to W_{rM} from the antenna weight control error e and outputs from the delay circuit 15. The
25 antenna weight control circuit 16 adaptively controls the

antenna weights W_{r1} to W_{rM} based on the MMSE standard so as to minimize the mean square value of the antenna weight control error e . When the LMS algorithm is employed as an update algorithm with a small arithmetic amount, the
5 antenna weights W_{r1} to W_{rM} are given by

$$W_r(i+1) = W_r(i) + \mu r(i-D_{dem}) e^*(i) \quad \dots (1)$$

where $W_r(i)$ (column vector having M elements) is the antenna weight of the i th symbol, $r(i)$ (column vector having M elements) is the antenna reception signal, μ is
10 the step size, D_{dem} is a delay time given by the delay circuit 15, and $*$ is the complex conjugate. From equation (1), the antenna weights W_{r1} to W_{rM} are updated every symbol. The adaptive control convergence step may use a known symbol instead of the determination symbol.

15 The M antenna reception signals S_1 to S_M contain desired (user) signal components, interference signal components, and thermal noise. Each of the desired signal component and interference signal component contains a multipath component. In general, these signal components
20 arrive from different directions. In forming a reception directional pattern, the conventional array antenna reception apparatus shown in Fig. 1 uses an antenna having antenna elements laid out circularly. Thus, a directional pattern with almost uniform reception gains in all the
25 signal arrival directions can be formed.

However, first, the conventional array antenna reception apparatus shown in Fig. 1 cannot attain a high reception gain proportional to the number of antenna elements.

5 This is because the directional pattern with almost uniform reception gains in all the signal arrival directions is formed by circularly laying out antenna elements, and the reception gain cannot be optimized.

Second, as the number of antenna elements increases, 10 the conventional array antenna reception apparatus shown in Figs. 1 and 2 decreases in adaptive convergence and stability in forming a directional pattern in the desired user direction.

This is because in the antenna having antenna 15 elements laid out circularly, all the antenna elements must be simultaneously adaptively controlled.

SUMMARY OF THE INVENTION

The present invention has been made in consideration of the above situation in the prior art, and has as its 20 object to provide an array antenna reception apparatus which can attain a high reception gain proportional to the number of antenna elements and is excellent in adaptive control convergence and stability in forming a directional pattern in the user direction.

25 To achieve the above object, an array antenna

reception apparatus according to the main aspect of the present invention is constituted as follows. Antenna elements are linearly laid out on each side (sector) of a polygon, a directional pattern for suppressing interference with another user or multipath is independently formed for each sector, and weighting synthesis is done between sectors. More specifically, the array antenna reception apparatus comprises an array antenna having M (M is an integer of not less than 1) antenna elements linearly laid out on each side (sector) of a polygon having K (K is an integer of not less than 3) sides, K adaptive receivers each for receiving reception signals from the M antenna elements for a corresponding sector, independently forming a directional pattern having a gain in a desired signal direction for the sector, receiving a desired signal, and suppressing an interference signal, and a demodulated signal synthesizer for receiving K demodulated signals as outputs from the K adaptive receivers, weighting and synthesizing the signals, and outputting a demodulated signal for a user.

In the present invention, since the antenna elements are linearly laid out every sector, a directional pattern with a high reception gain substantially proportional to the number of antenna elements can be formed in a direction perpendicular to each straight line (each sector

side). Since the directional pattern is independently formed for each sector, the number of antenna elements simultaneously adaptively controlled can be decreased. Even if the number of antenna elements increases, the
5 adaptive convergence and stability are kept high in forming a directional pattern in a desired user direction.

The above and many other objects, features and advantages of the present invention will become manifest to those skilled in the art upon making reference to the
10 following detailed description and accompanying drawings in which preferred embodiments incorporating the principle of the present invention are shown by way of illustrative examples.

BRIEF DESCRIPTION OF THE DRAWINGS

15 Fig. 1 is a block diagram showing the arrangement of a conventional array antenna reception apparatus;

Fig. 2 is a block diagram showing the arrangement of an adaptive receiver in the prior shown in Fig. 1;

20 Fig. 3 is a block diagram showing the arrangement of an array antenna reception apparatus according to an embodiment of the present invention;

Fig. 4 is a block diagram showing the arrangement of an adaptive receiver in the embodiment shown in Fig. 3;

25 Fig. 5 is a block diagram showing the arrangement of an array antenna reception apparatus according to another

embodiment of the present invention; and

Fig. 6 is a block diagram showing the arrangement of an adaptive receiver in the embodiment shown in Fig. 5.

DETAILED DESCRIPTION OF PREFERRED EMBODIMENTS

5 Several preferred embodiments of the present invention will be described in detail below with reference to the accompanying drawings.

In this case, a multiplexed input signal is a code division multiple signal. The first embodiment will
10 exemplify an array antenna reception apparatus (CDMA adaptive reception apparatus) for the number K (K is an integer of 3 or more) of sides (sectors) of a polygon in an antenna and the number M (M is an integer of 1 or more) of antenna elements in each sector.

15 Referring to Fig. 3, the array antenna reception apparatus according to the first embodiment of the present invention is constituted by an antenna 1 for receiving radio signals to output antenna reception signals (S_{11} to S_{KM}), adaptive receivers 3_1 to 3_K for receiving the antenna
20 reception signals of corresponding sectors to output demodulated sector signals (S_{D1} to S_{DK}) of the corresponding sectors, a demodulated signal synthesizer 4, and a determination circuit 5.

The antenna 1 is made up of antenna elements 2_{11} to
25 2_{KM} linearly laid out on respective sides (sectors) of a

- 10 -

K-side polygon in units of M elements. The k th sector will be mainly described.

The antenna elements 2_{k1} to 2_{kM} in the k th sector are close to each other so as to establish correlations
5 between the antenna reception signals S_{k1} to S_{kM} in the k th sector, and receive signals obtained by code-multiplexing desired signals and a plurality of interference signals. Each of the antenna elements 2_{k1} to 2_{kM} is not particularly limited in horizontal plane directivity, and desirably
10 takes monopole directivity with a beam width of 180° or less. When the antenna elements 2_{k1} to 2_{kM} take monopole directivity with a beam width of 180° or less, they must be arranged to form directivity outside the polygon of the antenna 1. When the antenna elements 2_{k1} to 2_{kM} do not
15 take monopole directivity with a beam width of 180° or less (i.e., omnidirectivity or dipole directivity), a radio shielding member must be disposed inside the K-side polygon of the antenna 1 so as not to receive signals by the antenna elements 2_{k1} to 2_{kM} with directivity inside the
20 k th side (k th sector) of the K-side polygon of the antenna 1. In the following processing, since signals are digitally processed in the baseband, M antenna reception signals $k1$ to kM received by the antenna elements 2_{k1} to 2_{kM} of the k th sector of the antenna 1 are
25 frequency-converted from the radio band to the baseband

and A/D-converted.

The demodulated signal synthesizer 4 receives K demodulated 1st- to kth-sector signals S_{D1} to S_{DK} as outputs from the adaptive receivers 3_1 to 3_K , weights and synthesizes them, and outputs a demodulated signal for a user. The weighting synthesis method in the demodulated signal synthesizer 4 is not particularly limited, and includes a method of selecting only a demodulated signal having the maximum desired signal power, a method of selecting only a demodulated signal having the maximum ratio (SIR) of desired signal power to interference power, and a maximum ratio synthesizing method of maximizing the ratio of desired signal power to interference power.

The determination circuit 5 receives a demodulated signal for a user as an output from the demodulated signal synthesizer 4 and performs hard determination for the demodulated signal, thereby outputting a user determination symbol. Here, it should be noted that only one of the determination circuit 5 is shown in Fig. 3, but other circuits are omitted.

Referring to Fig. 4, the adaptive receiver 3_K of the kth sector is constituted by despread circuits 6_{K1} to 6_{KM} , weighting synthesizer 7, demodulator 10, complex multiplier 13, subtracter 14, delay circuit 15, and antenna weight control circuit 16. The adaptive receiver

- 12 -

3_k of the kth sector receives the antenna reception signals k1 to kM received by the M antenna elements 2_{k1} to 2_{kM} linearly laid out in one sector, and the user determination symbol as an output from the determination circuit 5, and outputs a demodulated kth-sector signal.

The despread circuits 6_{k1} to 6_{kM} calculate correlations between the antenna signals k1 to kM and a user spread code C. Assuming that the spread code C is a complex code made up of two quadrature codes C_I and C_Q, the despread circuits 6_{k1} to 6_{kM} can be realized by one complex multiplier and averaging circuits over the symbol section. The despread circuits 6_{k1} to 6_{kM} can also be realized by a transversal filter arrangement with a tap weight C.

The weighting synthesizer 7 comprises complex multipliers 8_{k1} to 8_{kM} and adder 9. The weighting synthesizer 7 multiplies outputs from the despread circuits 6_{k1} to 6_{kM} by antenna weights W_{rk1} to W_{rkM}, and adds them to generate a signal received with a directional pattern unique to a desired user.

The demodulator 10 comprises a transmission path estimation circuit 11 and complex multiplier 12. The product of an output from the weighting synthesizer 7 and the complex conjugate of a transmission path estimation output is the demodulated kth-sector signal as an output from the adaptive receiver 3_k of the kth sector.

- 13 -

The complex multiplier 13 multiplies the user determination symbol by the transmission path estimation output. In multiplying the user determination symbol by the transmission path estimation output, only a component about the phase of the estimation value can be multiplied, and an amplitude obtained by another means can be multiplied. This another means is one for obtaining the amplitude by measuring, e.g., reception power.

The subtracter 14 calculates the difference between an output from the complex multiplier 13 and an output from the weighting synthesizer 7, and detects an antenna weight control error e_k .

The delay circuit 15 delays outputs from the despread circuits 6_{k1} to 6_{kM} in accordance with the processing times of the weighting synthesizer 7, demodulator 10, subtracter 14, and the like.

The antenna weight control circuit 16 calculates the antenna weights W_{rk1} to W_{rkM} from the antenna weight control error e_k and outputs from the delay circuit 15. The antenna weight control circuit 16 adaptively controls the antenna weights W_{rk1} to W_{rkM} based on the MMSE standard so as to minimize the mean square value of the antenna weight control error e_k . When the LMS algorithm is employed as an update algorithm with a small arithmetic amount, the antenna weights W_{rk1} to W_{rkM} are given by

- 14 -

$$W_{rk}(i+1) = W_{rk}(i) + \mu r(i-D_{dem}) e_k^*(i) \quad \dots (2)$$

where $W_{rk}(i)$ (column vector having M elements) is the antenna weight of the i th symbol, $r(i)$ (column vector having M elements) is the antenna reception signal, μ is the step size, D_{dem} is a delay time given by the delay circuit 15, and $*$ is the complex conjugate. From equation (2), the antenna weights W_{rk1} to W_{rkM} are updated every symbol. The step size μ as a change amount coefficient in updating the antenna weights W_{rk1} to W_{rkM} has the following feature. When the step size μ is large, the convergence speed to the antenna weights W_{rk1} to W_{rkM} for forming an optimum directional pattern is high, but the adaptive precision and stability are low; when the step size μ is small, the adaptive precision and stability are high, but the convergence speed is low. Thus, the step size is adaptively changed to obtain a satisfactory convergence speed, adaptive precision, and stability. This method is also incorporated in the present invention. The adaptive control convergence step may use a known symbol instead of the determination symbol.

The effects of the first embodiment according to the present invention will be explained. In the first embodiment of the present invention, since the antenna elements 2_{k1} to 2_{kM} are linearly laid out every sector, a directional pattern with a high reception gain

- 15 -

substantially proportional to the number of antenna elements can be formed in a direction perpendicular to the linear layout of the antenna elements 2_{k1} to 2_{kM} .

Since the directional pattern is independently formed
5 for each sector, the number of antenna elements simultaneously adaptively controlled decreases. Even if the number of antenna elements increases, the adaptive convergence and stability are kept high in forming a directional pattern in a desired user direction.

10 The second embodiment of the present invention will be described in detail with reference to Figs. 5 and 6. In this case, a multiplexed input signal is a code division multiple signal. The second embodiment will exemplify an array antenna reception apparatus (CDMA
15 adaptive reception apparatus) for the number K (K is an integer of 3 or more) of sides (sectors) of a polygon in an antenna and the number M (M is an integer of 1 or more) of antenna elements in each sector.

Referring to Fig. 5, the array antenna reception
20 apparatus according to the present invention is constituted by an antenna 1, adaptive receivers 17_1 to 17_K , and demodulated signal synthesizer 4.

The antenna 1 is made up of antenna elements 2_{11} to 2_{kM} linearly laid out on respective sides (sectors) of a
25 K -side polygon in units of M elements. The k th sector

- 16 -

will be mainly described.

The antenna elements 2_{k1} to 2_{kM} in the k th sector are close to each other so as to establish correlations between antenna reception signals in the k th sector, and receive signals obtained by code-multiplexing desired signals and a plurality of interference signals. Each of the antenna elements 2_{k1} to 2_{kM} is not particularly limited in horizontal plane directivity, and desirably takes monopole directivity with a beam width of 180 degrees or less. When the antenna elements 2_{k1} to 2_{kM} take monopole directivity with a beam width of 180 degrees or less, they must be arranged to form directivity outside the polygon of the antenna 1. When the antenna elements 2_{k1} to 2_{kM} do not take monopole directivity with a beam width of 180 degrees or less (i.e., omnidirectivity or dipole directivity), a radio shielding member must be disposed inside the K -side polygon of the antenna 1 so as not to receive signals by the antenna elements 2_{k1} to 2_{kM} with directivity inside the k th side (k th sector) of the K -side polygon of the antenna 1. In the following processing, since signals are digitally processed in the baseband, M antenna reception signals $k1$ to kM received by the antenna elements 2_{k1} to 2_{kM} of the k th sector of the antenna 1 are frequency-converted from the radio band to the baseband and A/D-converted.

- 17 -

The demodulated signal synthesizer 4 receives K demodulated 1st- to kth-sector signals as outputs from the adaptive receivers 17_1 to 17_K , weights and synthesizes them, and outputs a demodulated signal for a user. The weighting synthesis method in the demodulated signal synthesizer 4 is not particularly limited, and includes a method of selecting only a demodulated signal having the maximum desired signal power, a method of selecting only a demodulated signal having the maximum ratio (SIR) of desired signal power to interference power, and a maximum ratio synthesizing method of maximizing the ratio of desired signal power to interference power.

Referring to Fig. 6, the adaptive receiver 17_K of the kth sector is constituted by despread circuits 6_{k1} to 6_{kM} , weighting synthesizer 7, demodulator 10, arrival direction estimation circuit 18, and antenna weight generation circuit 19. The adaptive receiver 17_K of the kth sector receives the antenna reception signals $k1$ to kM received by the M antenna elements 2_{k1} to 2_{kM} linearly laid out in one sector, and outputs a demodulated kth-sector signal.

The despread circuits 6_{k1} to 6_{kM} calculate correlations between the antenna signals $k1$ to kM and a user spread code C. Assuming that the spread code C is a complex code made up of two quadrature codes C_I and C_Q , the despread circuits 6_{k1} to 6_{kM} can be realized by one complex

multiplier and averaging circuits over the symbol section. The despread circuits 6_{k1} to 6_{kM} can also be realized by a transversal filter arrangement with a tap weight C .

The weighting synthesizer 7 comprises complex
5 multipliers 8_{k1} to 8_{kM} and adder 9. The weighting synthesizer 7 multiplies outputs from the despread circuits 6_{k1} to 6_{kM} by antenna weights W_{rk1} to W_{rkM} , and adds them to generate a signal received with a directional pattern unique to a desired user.

10 The demodulator 10 comprises a transmission path estimation circuit 11 and complex multiplier 12. The product of an output from the weighting synthesizer 7 and the complex conjugate of a transmission path estimation output is the demodulated k th-sector signal as an output
15 from the adaptive receiver 17_k of the k th sector.

The arrival direction estimation circuit 18 receives outputs from the despread circuits 6_{k1} to 6_{kM} , and estimates the arrival direction of a desired signal from a reception signal multiplexed by a plurality of user
20 signals. The arrival direction estimation method in the arrival direction estimation circuit 18 is not limited, and includes, e.g., the MUSIC method.

The antenna weight generation circuit 19 receives an estimated arrival direction signal as an output from the
25 arrival direction estimation circuit 18, and calculates

and outputs the antenna weights W_{rk1} and W_{rkM} for forming a directional pattern with the maximum reception gain in the estimated arrival direction.

The effects of the second embodiment according to the present invention will be explained. In the second embodiment of the present invention, an arrival direction is estimated in the adaptive receivers 17_1 to 17_k , and the antenna weights W_{rk1} and W_{rkM} are generated from the estimated arrival direction. In the first embodiment of the present invention, adaptive control is closed-loop control. To the contrary, in the second embodiment of the present invention, adaptive control is open loop control and thus can be stably done without any divergence.

The above embodiments of the present invention do not limit the code length of the spread code C , i.e., the spread ratio. The array antenna reception apparatus according to the present invention can be applied to even a signal multiplexed at a spread ratio of 1 by a method other than the code division multiple access method.

The above embodiments of the present invention do not limit the interval between antenna elements. For example, the interval is set to $1/2$ the wavelength of the carrier wave.

The above embodiments of the present invention do not limit the number K of sectors. For example, the polygon

is a triangle.

The above embodiments of the present invention do not limit the number M of antenna elements linearly laid out in one sector.

5 The above embodiments of the present invention do not limit the number of simultaneous reception users.

The above embodiments of the present invention do not limit the number of multipaths for simultaneous reception users.

WHAT IS CLAIMED IS:

1. An array antenna reception apparatus comprising:
an array antenna having M (M is an integer of not less
than 1) antenna elements linearly laid out on each side
5 (sector) of a polygon having K (K is an integer of not
less than 3) sides; K adaptive receivers each for
receiving reception signals from the M antenna elements
for a corresponding sector, independently forming a
directional pattern having a gain in a desired signal
10 direction for the sector, receiving a desired signal, and
suppressing an interference signal; and a demodulated
signal synthesizer for receiving K demodulated signals as
outputs from said K adaptive receivers, weighting and
synthesizing the signals, and outputting a demodulated
15 signal for a user.

2. An apparatus according to claim 1, wherein the
directional pattern of each sector of said array antenna
is formed outside each side of the polygon.

3. An apparatus according to claim 1, wherein said
20 demodulated signal synthesizer selects a demodulated
signal having maximum desired signal power in weighting
and synthesizing the K demodulated signals.

4. An apparatus according to claim 1, wherein said
demodulated signal synthesizer selects a demodulated
25 signal having a maximum ratio of desired signal power to

interference power in weighting and synthesizing the K demodulated signals.

5. An apparatus according to claim 1, wherein said demodulated signal synthesizer performs weighting
5 synthesis (maximum ratio synthesis) so as to maximize a ratio (SIR) of desired signal power to interference power in weighting and synthesizing the K demodulated signals.

6. An apparatus according to claim 1, wherein each of said K adaptive receivers comprises M despread means
10 for receiving code division multiple access (CDMA) signals received by said M antenna elements and a determination symbol obtained by hard determination for the demodulated signal for a user, and despreading each of the M antenna
15 reception signals using a desired user spread code, a weighting synthesizer for forming a directional pattern, a demodulator for estimating a transmission path, a multiplier for multiplying a user determination symbol by
20 a complex transmission path estimation value as an output from said demodulator to cancel a phase change caused by phase lock of a carrier wave, a subtracter for subtracting
an output from said weighting synthesizer from an output from said multiplier to detect an antenna weight control error, delay means for delaying outputs from said M spread
25 means in accordance with a processing time of said demodulator, and antenna weight control means for

controlling and outputting antenna weights on the basis of a least mean square error (MMSE) so as to minimize average power of the antenna weight control error using outputs from said delay means and the antenna weight control error.

5 7. An apparatus according to claim 1, wherein each of said K adaptive receivers comprises M despread means for receiving code division multiple access (CDMA) signals received by said M antenna elements and despreading each of the M antenna reception signals using a desired user
10 spread code, arrival direction estimation means for estimating an arrival direction from outputs from said M despread means, antenna weight generation means for generating antenna weights from outputs from said arrival
15 direction estimation means, a weighting synthesizer for forming a directional pattern from the antenna weights, and a demodulator for estimating a transmission path.

8. An apparatus according to claim 6, wherein said weighting synthesizer comprises M complex multipliers for receiving the M antenna reception signals and the antenna
20 weights, and multiplying the received signals by M complex antenna weights, and an adder for adding outputs from said M complex multipliers.

9. An apparatus according to claim 6, wherein said demodulator comprises transmission path estimation means
25 for receiving an output from said weighting synthesizer

- 24 -

and estimating an amplitude and phase of the carrier wave,
complex conjugate operation means for obtaining a complex
conjugate of a complex transmission path estimation value
as an output from said transmission path estimation means,
5 and a multiplier for multiplying an output from said
despread means by an output from said complex conjugate
operation means to phase-lock the carrier wave.

**Smart & Biggar
Ottawa, Canada
Patent Agents**

FIG.1 PRIOR ART

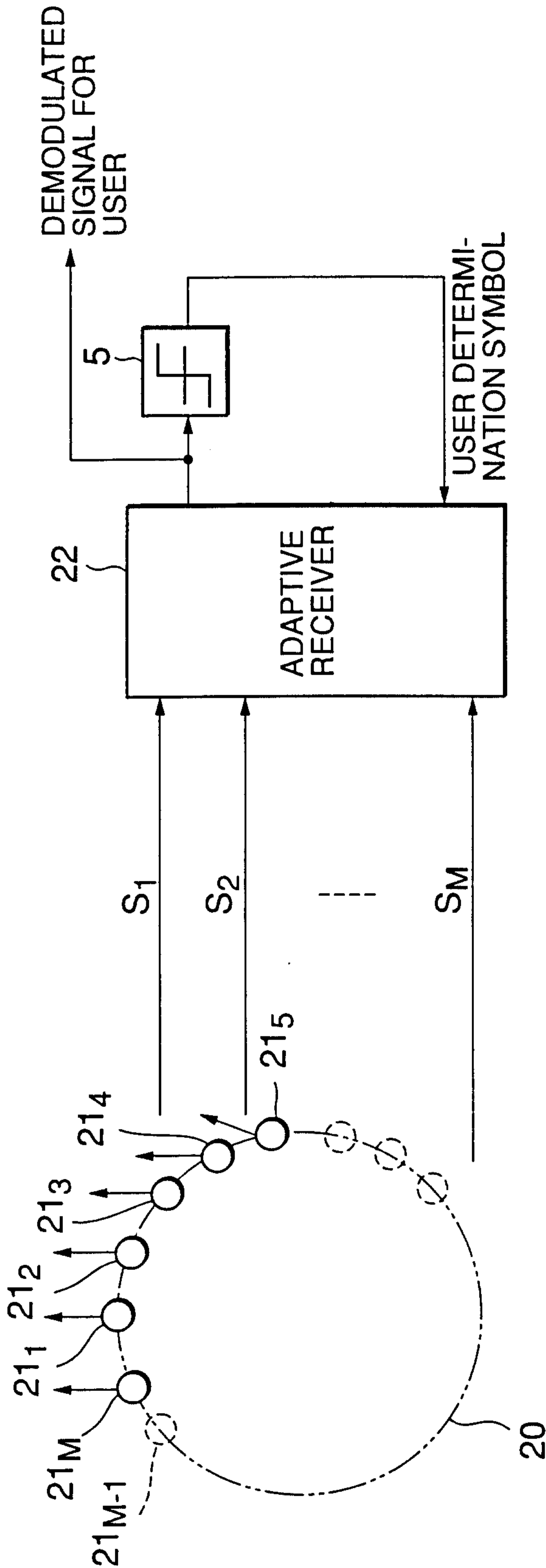

FIG.2 PRIOR ART

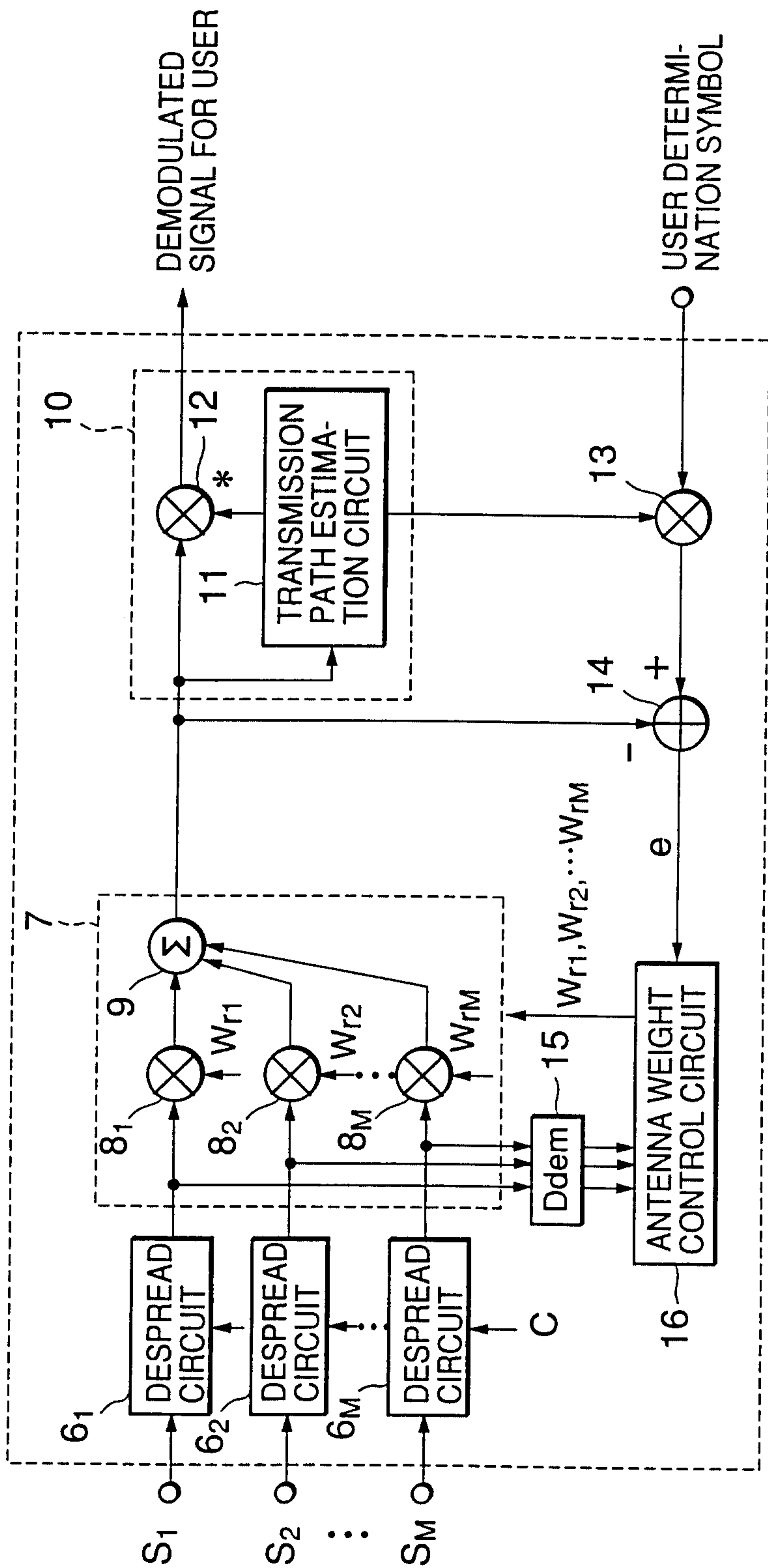

FIG.3

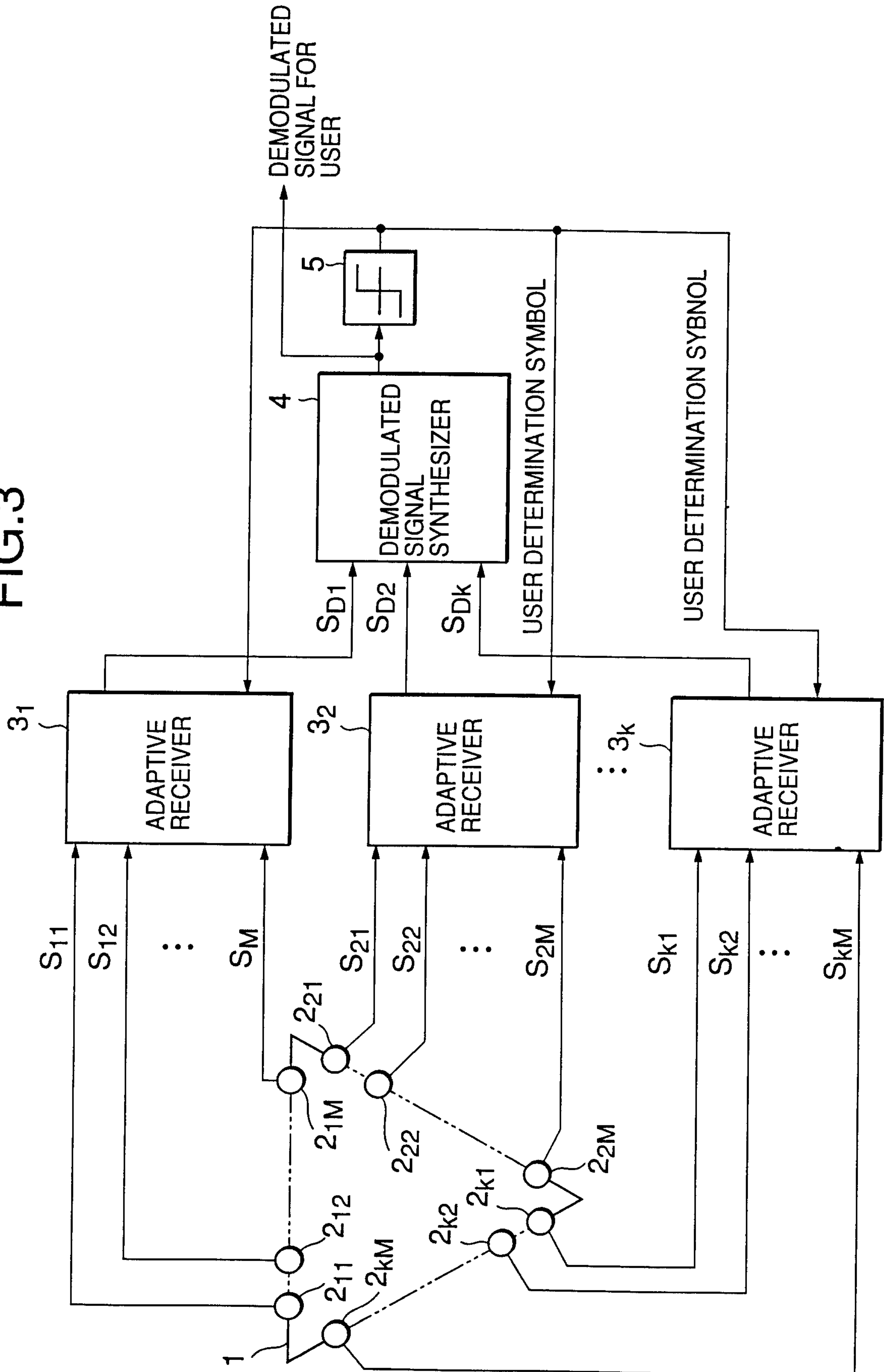

FIG.4

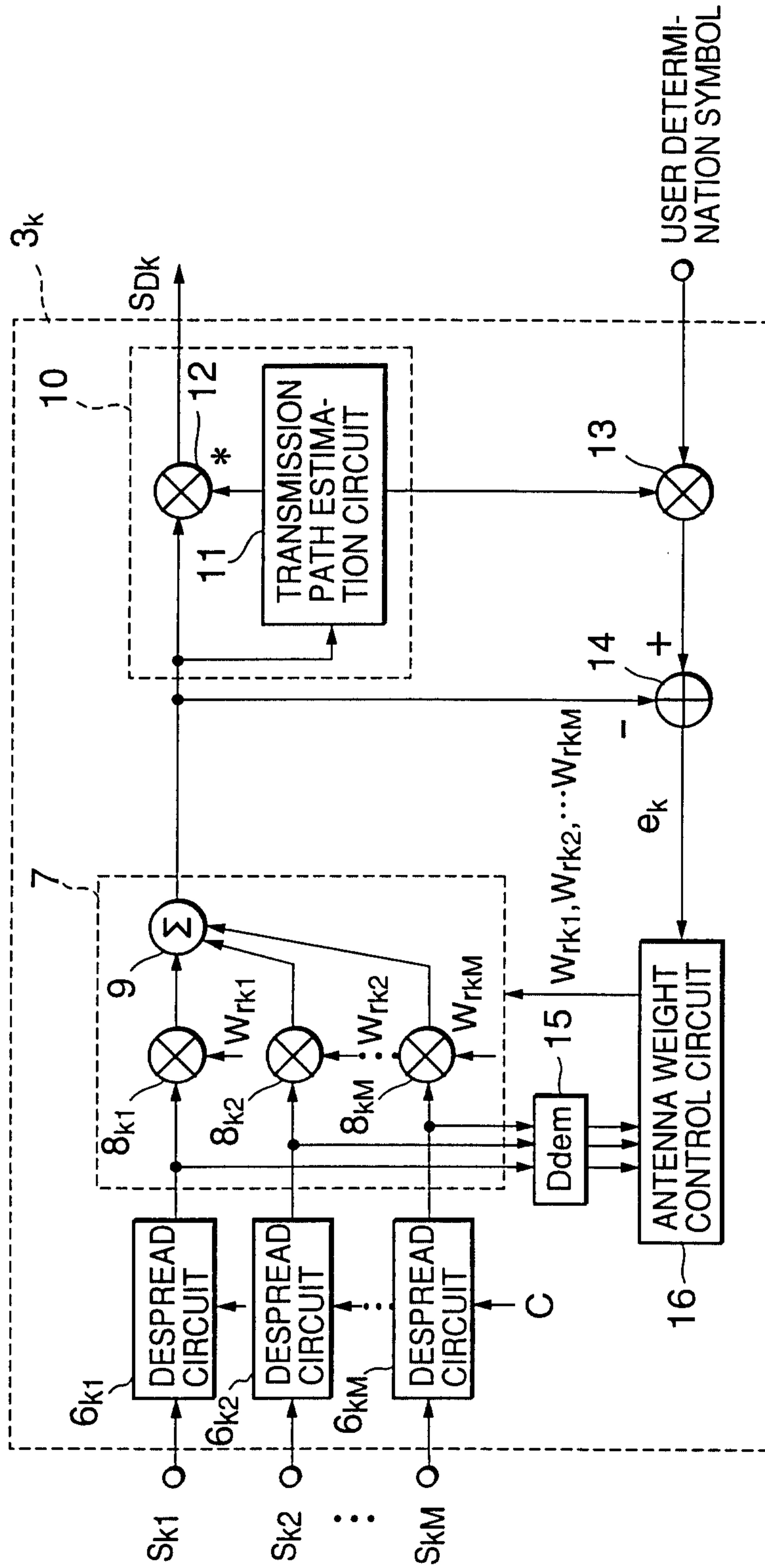

FIG.5

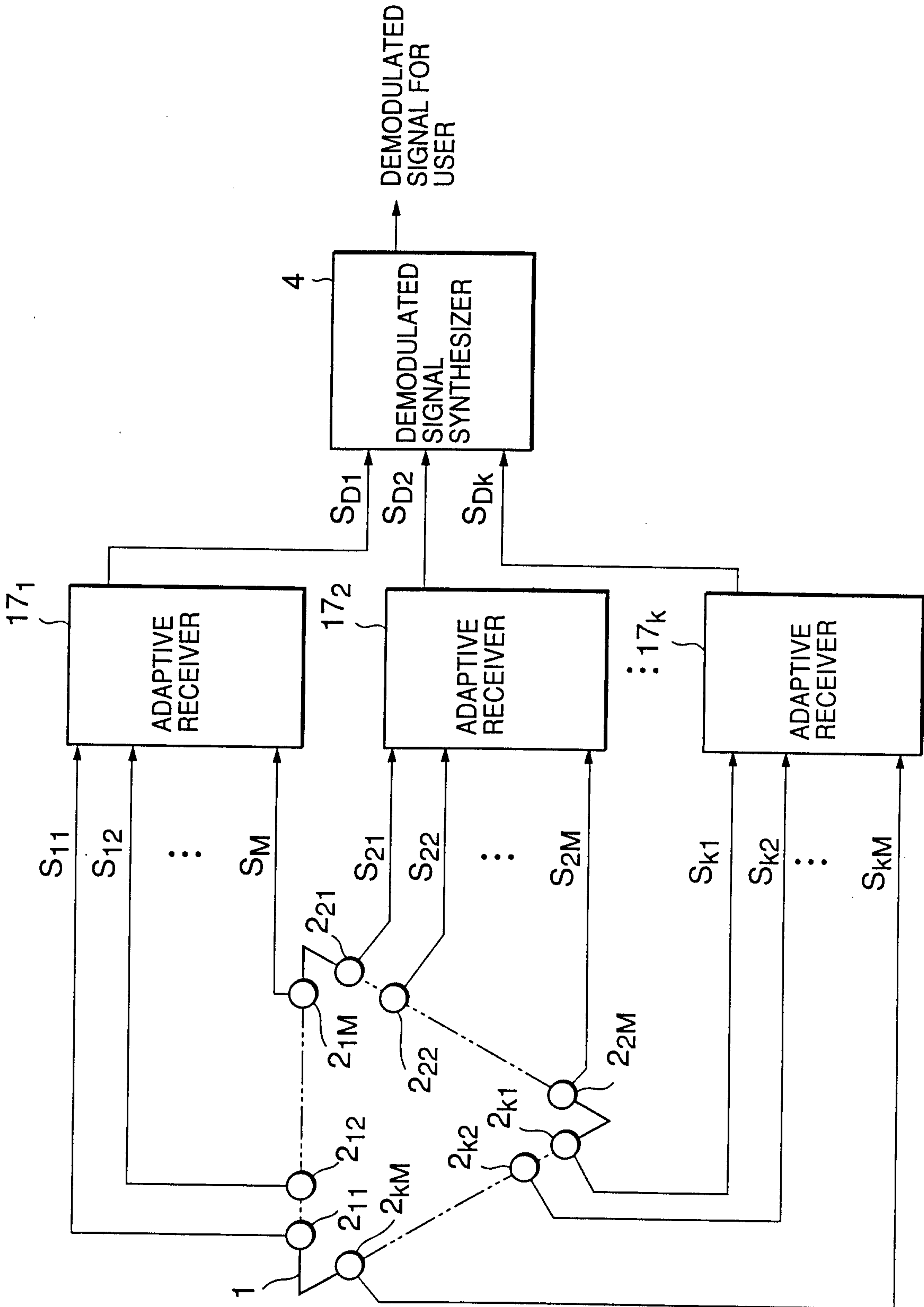

FIG.6

