

(12) INTERNATIONAL APPLICATION PUBLISHED UNDER THE PATENT COOPERATION TREATY (PCT)

(19) World Intellectual Property
Organization

International Bureau

(43) International Publication Date
15 November 2018 (15.11.2018)



(10) International Publication Number
WO 2018/209177 A1

(51) International Patent Classification:

A61F 2/30 (2006.01) A61L 27/40 (2006.01)
A61L 2/00 (2006.01)

Published:

- with international search report (Art. 21(3))
- before the expiration of the time limit for amending the claims and to be republished in the event of receipt of amendments (Rule 48.2(h))

(21) International Application Number:

PCT/US2018/032215

(22) International Filing Date:

11 May 2018 (11.05.2018)

(25) Filing Language:

English

(26) Publication Language:

English

(30) Priority Data:

62/505,257 12 May 2017 (12.05.2017) US

(71) Applicant: **CUTTING EDGE SPINE LLC** [US/US]; 101 Waxhaw Professional Park Drive, Suite A, Waxhaw, NC 28173 (US).

(72) Inventors; and

(71) Applicants: **KYLE, Kuntz** [US/US]; 3706 Wilshire Lane, Waxhaw, NC 28173 (US). **PATEL, Shyam** [US/US]; 2005 Belle Forest Court, Waxhaw, NC 28173 (US).

(74) Agent: **DOBREA, Diane, H.**; McNeese Wallace & Nurick LLC, 21 East State Street, Suite 1700, Columbus, OH 43215 (US).

(81) Designated States (unless otherwise indicated, for every kind of national protection available): AE, AG, AL, AM, AO, AT, AU, AZ, BA, BB, BG, BH, BN, BR, BW, BY, BZ, CA, CH, CL, CN, CO, CR, CU, CZ, DE, DJ, DK, DM, DO, DZ, EC, EE, EG, ES, FI, GB, GD, GE, GH, GM, GT, HN, HR, HU, ID, IL, IN, IR, IS, JO, JP, KE, KG, KH, KN, KP, KR, KW, KZ, LA, LC, LK, LR, LS, LU, LY, MA, MD, ME, MG, MK, MN, MW, MX, MY, MZ, NA, NG, NI, NO, NZ, OM, PA, PE, PG, PH, PL, PT, QA, RO, RS, RU, RW, SA, SC, SD, SE, SG, SK, SL, SM, ST, SV, SY, TH, TJ, TM, TN, TR, TT, TZ, UA, UG, US, UZ, VC, VN, ZA, ZM, ZW.

(84) Designated States (unless otherwise indicated, for every kind of regional protection available): ARIPO (BW, GH, GM, KE, LR, LS, MW, MZ, NA, RW, SD, SL, ST, SZ, TZ, UG, ZM, ZW), Eurasian (AM, AZ, BY, KG, KZ, RU, TJ, TM), European (AL, AT, BE, BG, CH, CY, CZ, DE, DK, EE, ES, FI, FR, GB, GR, HR, HU, IE, IS, IT, LT, LU, LV, MC, MK, MT, NL, NO, PL, PT, RO, RS, SE, SI, SK, SM, TR), OAPI (BF, BJ, CF, CG, CI, CM, GA, GN, GQ, GW, KM, ML, MR, NE, SN, TD, TG).

(54) Title: IMPLANTS FOR TISSUE FIXATION AND FUSION

(57) Abstract: A fixation implant includes a head, a shank and a distal tip, and one or more of the head, shank and distal tip may be cannulated. The shank includes a threaded ingrowth portion extending from the head to the tapered distal tip that includes external threads, and at least one open network body extending along the length of the ingrowth portion. The open network body selected from one or a combination of a helix, an arrangement of trusses, a scaffold of open and interconnected pores, a porous framework of random open and interconnected pores, and combinations of these.



WO 2018/209177 A1

IMPLANTS FOR TISSUE FIXATION AND FUSION**[001] RELATED APPLICATION:**

[002] This application claims the benefit under 35 U.S.C. §119(e) to U.S. Provisional Application Ser. No. 62/505,257 filed May 12, 2017, the entirety of which is incorporated herein by reference.

[003] FIELD:

[004] The present application describes various exemplary devices and surgical techniques for securing tissue, particularly bone tissue, and more particularly in some examples, bone tissue in the spine associated with the sacroiliac joint.

[005] DESCRIPTION OF THE RELATED ART

[006] In the context of orthopedics, a variety of conditions, including injuries, degeneration, and congenital abnormalities can present the need for interventional implants and surgical techniques to achieve one or more of bone repair, stabilization, and correction. Conventional procedures have been developed using mechanical implants, for example to straighten or otherwise stabilize joints, secure fragments of fractured bones, and secure and stabilize successive vertebrae, sacral iliac bones, and other adjacent bones in a fixed position. These implants include bone screws, anchors, rods, bands, plates, and combinations of these devices that are comprised of one or a combination of metal, polymers, biomaterials and other biologically acceptable materials.

[007] In one example, fixation and fusion is needed for addressing sacroiliac dysfunction or instability that occurs in the sacroiliac joint. In a typical subject, the sacroiliac joint spans between the sacrum bone and ilium bone, and has a natural degree of motion, or nutation, of one to two degrees. In the case of injury to the joint, the typically small range of motion can be exaggerated and lead to hypermobility, an often difficult condition to diagnose because it involves lower back and leg pain which are symptoms that are common with other spinal and orthopedic problems. Once diagnosed, there are surgical options for fixation and

fusion of the sacroiliac joint. But due to the natural movement of the joint, typical bone screw type implants can be vulnerable to rotation and ultimate failure.

[008] Accordingly, there is a need for implant devices that can straighten or otherwise stabilize joints, secure fragments of fractured bones, and secure and stabilize successive vertebrae, sacral iliac bones, and other adjacent bones in a fixed position. Such improved devices are needed for the maintenance of stability of securement of the bones, for example prevention of rotation of one or both of bone and implant that can destabilize fixation and cause movement or migration of the joined bone, of the implant, and combinations of these. Thus, applications would include correcting instability and hypermobility in fixated joints, and providing resistance to rotational and pull out failures in order to achieve the desirable degree of fusion across a joint, across joined portions of bone, and in the context of implants secured to bone. In some particular applications, there is a need for devices that enhance and provide more secure fixations of the sacroiliac joint, including greater bone purchase and retention, and features for enhanced tissue integration.

[009] BRIEF DESCRIPTION OF THE DRAWINGS

[010] Features and advantages of the general inventive concepts will become apparent from the following description made with reference to the accompanying drawings, including drawings represented herein in the attached set of figures, of which the following is a brief description:

[011] FIG 1 shows another embodiment of a fixation implant characterized in having an external thread over an open helical body, and shown in oblique, side and side cross sectional views;

[012] FIG 2 shows yet another embodiment of a fixation implant characterized in having an external thread over an open helical body having an solid inner cylindrical through channel, and shown in oblique, side and side cross sectional views;

[013] FIG 3 shows yet another embodiment of a fixation implant characterized in having an external thread over an open organized truss arrangement, and shown in oblique, side and side cross sectional views;

[014] FIG 4 shows another embodiment of a fixation implant characterized in having an external thread over an open organized truss arrangement with a solid inner cylindrical through channel, and shown in oblique, side and side cross sectional views;

[015] FIG 5 shows another embodiment of a fixation implant characterized in having an external thread over an open helical body that includes two helices having different pitches, and shown in oblique, side and side cross sectional views;

[016] FIG 6 shows another embodiment of a fixation implant characterized in having an external thread over an open disorganized truss arrangement with a solid inner cylindrical through channel, and shown in oblique, side and side cross sectional views;

[017] FIG 7 shows another embodiment of a fixation implant characterized in having an external thread over an open helical body, wherein the implant is not cannulated and is shown in oblique, side and side cross sectional views;

[018] FIG 8 shows another embodiment of a fixation implant characterized in having an external thread over an open and continuous disorganized truss arrangement wherein the implant is not cannulated and is shown in oblique, side and side cross sectional views; and,

[019] FIG 9 shows three alternate embodiments of a fixation implant, the uppermost image depicting a non-cannulated implant having exterior threading and an interior framework of random open and interconnected pores, shown in a side cross sectional view; the middle image depicting a variation of the fixation member of the upper image that is only partially formed with the interior framework, shown in a side cross sectional view; and, the third and bottom image depicting an alternate embodiment of a non-cannulated implant having exterior threading and a porous interior framework of random open and interconnected pores, shown in a side cross sectional view.

[020] This disclosure describes exemplary embodiments in accordance with the general inventive concepts and is not intended to limit the scope of the invention in any way. Indeed, the invention as described in the specification is broader than and unlimited by the exemplary embodiments set forth herein, and the terms used herein have their full ordinary meaning.

[021] DETAILED DESCRIPTION

[022] The general inventive concepts will now be described with occasional reference to the exemplary embodiments of the invention. The general inventive concepts may be embodied in different forms and should not be construed as limited to the embodiments set forth herein. Rather, these embodiments are provided so that this disclosure will be thorough and complete, and will fully convey the scope of the general inventive concepts to those skilled in the art.

[023] As used herein, the singular forms “a,” “an,” and “the” are intended to include the plural forms as well, unless the context clearly indicates otherwise. The term “proximal” as used in connection with any object refers to the portion of the object that is closest to the operator of the object (or some other stated reference point), and the term “distal” refers to the portion of the object that is farthest from the operator of the object (or some other stated reference point). The term “operator” means and refers to any professional or paraprofessional who delivers clinical care to a medical patient, particularly in connection with the delivery of care.

[024] Anatomical references as used herein are intended to have the standard meaning for such terms as understood in the medical community, and generally, any and all terms providing spatial references to anatomical features shall have meaning that is customary in the art. For example, the application may include reference to the following terms: “cephalad,” “cranial” and “superior” indicate a direction toward the head, and the terms “caudad” and “inferior” indicate a direction toward the feet. Likewise, the terms “dorsal” and “posterior” indicate a direction toward the back, and the terms “ventral” and “anterior” indicate a direction toward the front. And the term “lateral” indicates a direction toward a side of the patient. The term “medial” indicates a direction toward the mid line of the patient, and away from the side, the term “ipsilateral” indicates a direction toward a side that is proximal to the operator or the object being referenced, and the term “contralateral” indicates a direction toward a side that is distal to the operator or the object being referenced.

[025] “Patient” is used to describe an animal, preferably a human, to whom treatment is administered, including prophylactic treatment with the compositions of the present invention.

“Concave” is used herein to describe an indented surface without reference to the specific shape of the indented surface. As non-limiting examples, the concave face may be tubular with a round cross section, oval cross section, square cross section, or rectangular cross section.

[026] Unless otherwise indicated, all numbers expressing quantities, properties, and so forth as used in the specification, drawings and claims are to be understood as being modified in all instances by the term “about.” Accordingly, unless otherwise indicated, the numerical properties set forth in the specification and claims are approximations that may vary depending on the suitable properties desired in embodiments of the present invention. Notwithstanding that the numerical ranges and parameters setting forth the broad scope of the general inventive concepts are approximations, the numerical values set forth in the specific examples are reported as precisely as possible. Any numerical values, however, inherently contain certain errors necessarily resulting from error found in their respective measurements.

[027] References to visualization using radiography as may be described in the exemplary techniques herein are merely representative of the options for the operator to visualize the surgical field and the patient in one of many available modalities. It will be understood by one of ordinary skill in the art that alternate devices and alternate modalities of visualization may be employed depending on the availability in the operating room, the preferences of the operator and other factors relating to exposure limits. While confirmation of instrument placement in the course of the technique is appropriate, the frequency and timing relative to the sequence of steps in the technique may be varied and the description herein is not intended to be limiting. Accordingly, more or fewer images, from more or fewer perspectives, may be collected.

[028] One of ordinary skill will appreciate that references to positions in the body are merely representative for a particular surgical approach. Further, some references herein are made in the context of the representative images shown in the drawings. Fewer or additional instruments, including generic instruments, may be used according to the preference of the operator. Moreover, references herein to specific instruments are not intended to be limiting in terms of the options for use of other instruments where generic options are available, or according to the preference of the operator.

[029] The present application describes various embodiments of devices for joint and

other bone fixation. In some particular embodiments, devices for fixation of the sacroiliac joint are provided. It will be appreciated that the examples and drawings, as shown herein, may be described in reference to use in applications for sacroiliac joint fusion, though the devices as disclosed herein may be used in any of a variety of other orthopedic applications, and may be used alone, or as an adjunct to devices used for other fixation or correction, such as, for example, in spine fusion surgery, to help hold other implants in place.

[030] Fixation Implants

[031] In accordance with various embodiments, the invention provides a fixation implant that comprises fixation member having a proximal head and a shank with a distal tip. The fixation implant is advantageously used for accomplishing fixation of tissue, such as bone tissue, in some examples including adjacent bones at a joint such as the sacroiliac joint, or bone fracture fragments. The implant provides enhanced resistance to rotational motion, rotational migration and pull out as compared with other fixation member designs, this advantage owing to one or more of increased bone engagement surface, enhanced opportunity for osseointegration, and enhanced bone purchase as a result of the extensively enhanced surface area of the three-dimensional open structure of at least a portion of the implant. The fixation implant includes one or more of head and shank features modeled to resemble the open and interconnected porosity features of trabecular bone in a variety of different embodiments.

[032] In accordance with the various embodiments, the shank of the fixation member includes one or more openings or slots through the shank, in some embodiments arranged as a plurality around the periphery of the shank, to further enhance bony ingrowth. The openings are referred to herein as an open core and are formed of an open network body that provides a framework comparable to that of trabecular bone. As further described herein, an open core may be formed within any of the head and the shank portions and comprises at least one open network body. In some particular embodiments, the shank portion includes an open core comprising an open network body and one or both of the head and distal tip are solid and may include a through cannula. In some embodiments, an open network body may be selected from one or a combination of: at least one elongate helix; an organized arrangement of trusses; a

random arrangement of trusses; a framework or scaffold of random open and interconnected pores; and, a porous framework of random open and interconnected pores. Thus, in some embodiments, the entire fixation implant may have an open core formed of at least one type of open network structure or combinations thereof.

[033] In accordance with the various embodiments, the open network body of the fixation implant allows materials to move into or out of the open core of the shank, the materials including bone fillers and other materials that would encourage bony ingrowth. Of course, in some such embodiments, the fixation implants may be provided without any filler materials. In accordance with the various embodiments, all or any portion of the fixation implant may be formed of one or more of a metal and a polymer. In particular, the head, the shank, the open core and the distal tip may be partially or completely formed from one or a combination of materials selected from metal and a polymer. In some particular examples, all or a portion of the materials forming the trabecular body may be osseo-inductive, selected from materials such as titanium, or others. And in some embodiments, the entire fixation implant may have an open core formed of a metal, a polymer, or combinations of these with or without other additive materials such as hydroxyapatite, and the open core may be open or closed.

[034] An open network body has an open and interconnected matrix that allows communication between all bony material 360 degrees around the bone to optimize complete bony integration. This is advantageous over existing screw designs that have one or a series of fenestrations in an otherwise solid body of the shank, such fenestrations providing incomplete (i.e., less than 360 degree) engagement with bone. The three-dimensional structures of the open network body can provide greater support and stress distribution as compared to through holes and other fenestrations in the body of the shank of a conventional hollow screw that is designed to encourage bony ingrowth. Similar to the function of the trabeculae in bone, the open network structures of the open network body can allow for more even stress distribution than fenestrations would permit while also presenting open portions for bony ingrowth circumferentially at all points of circumferential contact with bone

[035] Referring now to FIG 1, an exemplary embodiment of a fixation member 100 is shown. The fixation member 100 is characterized in having a head 110, and a shank 130 with an

external thread 140 over an open core comprising a helical body 150 having the shape of a helix along the length of the shank 130, the fixation member 100 generally resembling the overall shape of a bone screw. According to the various embodiments, the open core as shown in FIG 1 in the form of a helical body 150 provides an example of an open network body according to the invention that is adapted to encourage bony growth through the implant when it is fixed in bone. As shown in FIG 1 and the other embodiments, the thread 140 is disposed on and integral with the helical body 150 forming the open network body of the open core, such that the helical body 150 is at least partially visible along the length of at least a portion of the shank 130 in the gaps between the thread 140, providing access into the helical body 150 to allow tissue infiltration and bony ingrowth therein.

[036] Referring again to FIG 1, in the exemplified embodiment, the fixation implant 100 includes a proximal head 110 that has a generally spherical in shape, and comprises a center through cannula 180 that passes from the head 110 through the distal tip 160, and a tool recess 120 for engaging a driving instrument. In alternate embodiments the head shape may be generally hemispherical, generally cylindrical, generally conical, and generally frustoconical. Each of the head 110 and distal tip 160 is cannulated and otherwise solid (i.e., it is not formed of an open network). In alternate embodiments, one or more of the distal tip 160 and the head 110 may be non-cannulated and solid, or may be cannulated and partially or entirely formed from one of a solid and an open network. Referring now to FIG 7 – FIG 9, as shown in alternate depicted embodiments, for example as shown in FIG 7, the head 710 and distal tip 760 are solid (not cannulated).

[037] The exemplified fixation implant 100 includes a shank 130 having a length defined between the proximal head 110 and a distal tip 160 and a shape that is generally cylindrical that does not taper from proximal to distal, with a distal tip 160 that is a tapered frustoconical shape. In alternate various embodiments, the shank shape is selected from generally cylindrical, generally conical and generally frustoconical. It will be appreciated that the shape and proportions of the implant are not intended to be limiting and that the relative dimensions of each of the head, shank and distal tip portions of the various embodiments may vary. In the various alternate embodiments, all or only a portion of the shank 130 may have one

or more an external thread 140 arranged around the open core along the length of the shank 130.

[038] In the various embodiments according to the disclosure, the open core is formed with an open network structure selected from one or a combination of: at least one elongate helix; an organized arrangement of trusses; a random arrangement of trusses; a framework or scaffold of random open and interconnected pores; and, a porous framework of random open and interconnected pores. Further, the open core may be open in its center (whether or not one or both of the head and the distal tip are cannulated), or it may be solid, or it may include an open network structure as described herein above, or it may comprise a solid inner wall, such as a cylindrical wall, or a fenestrated wall, or a combination of these. As briefly described herein, each of FIG 1, FIG 3, FIG 5, FIG 6 and FIG 7 depicts a fixation implant in which the open core has an open center (where FIG 7 is the one example in which the head and the distal tip are not cannulated), and, each of FIG 2 and FIG 4 depicts a fixation implant in which the open core includes at its center a solid cylindrical wall that is cannulated, and FIG 8 and FIG 9 each depict fixation implants in which the open core has a center that is continuously filled with the open network, and in which the head and the distal tip are not cannulated.

[039] It will be appreciated by one of ordinary skill in the art that while each of the depicted embodiments as shown in the drawings include various combinations of the features that include a head and a distal tip and a shank comprising one or open network bodies, there are numerous possible embodiments having combinations of features that are not shown in the drawings. Thus, in various alternate examples, the fixation implant may have any one or more of the following configurations along at least a portion of its length between the head and the distal tip, from proximal to distal: a through cannula surrounded by an open network body with exterior threading; a through cannula surrounded by a solid or fenestrated wall that is surrounded by an open network body with exterior threading; a solid that is surrounded by an open network body with exterior threading; and, a continuous open network body with exterior threading. Thus, FIG 1 is an example of a fixation implant that has a through cannula from the proximal head portion through the distal tip, each of the proximal head portion and tip being otherwise solid (not an open network) and the shank comprises a void (the through cannula) surrounded by an open network body.

[040] Referring now to FIG 2, yet another embodiment of a fixation implant 200 is shown being characterized in having a shank 230 comprising an external thread 240 over an open core, the open core comprising a helical body 250 having the shape of a helix along the length of the shank 230, the helical body 250 having within it a solid-walled inner cylindrical through channel 270. In the depicted embodiment, each of the head 210 and the distal tip 260 are cannulated 280, and the head 210 includes a tool recess 220 for engaging a driving instrument.

[041] Referring now to FIG 3, yet another embodiment of a fixation implant 300 is shown being characterized in having a shank 330 comprising an external thread 340 over an open core, the open core comprising an organized truss body 350. In the depicted embodiment, each of the head 310 and the distal tip 360 are cannulated 380, and the head 310 includes a tool recess 320 for engaging a driving instrument.

[042] Referring now to FIG 4, yet another embodiment of a fixation implant is shown having a shank 430 comprising an external thread 440 over an open core, the open core comprising an organized truss body 450 that has a solid-walled inner cylindrical through channel 470. In the depicted embodiment, each of the head 410 and the distal tip 460 are cannulated 480, and the head 410 includes a tool recess 420 for engaging a driving instrument.

[043] FIG 5 shows yet another embodiment of a fixation implant 500, the fixation implant 500 having a shank 530 characterized in having an external thread 540 over an open core comprising a dual helical body 550 that comprises two entwined helices, each helix having a different pitch. In the depicted embodiment, each of the head 510 and the distal tip 560 are cannulated 580, and the head 510 includes a tool recess 520 for engaging a driving instrument.

[044] Referring now to FIG 6, yet another embodiment of a fixation implant 600 is shown being characterized in having a shank 630 having an external thread 640 over an open core comprising a disorganized truss body 650 with a solid-walled inner cylindrical through channel 670. In the depicted embodiment, each of the head 610 and the distal tip 670 are cannulated 680, and the head 610 includes a tool recess 820 for engaging a driving instrument.

[045] Referring now to FIG 7, yet another embodiment of a fixation implant 700 is shown being characterized in having a shank 730 having an external thread 740 over an open

(containing a void) helical body 750, where in the depicted embodiment, each of the head 710 and the distal tip 760 are not cannulated, and the head 710 includes a tool recess 720 for engaging a driving instrument.

[046] Referring now to FIG 8, yet another embodiment of a fixation implant 800 is shown being characterized in having a shank 830 having an external thread 840 over an open and continuous disorganized truss body 850 wherein the shank 830, the head 810 and the distal tip 860 are not cannulated, and the head 810 includes a tool recess 120 for engaging a driving instrument.

[047] Referring now to FIG 9, three alternate embodiments of a fixation implant are shown. Referring to the top image of FIG 9, the depicted embodiment is a non-cannulated fixation implant 900 having exterior threading 940 and an open scaffold body 950 comprising a scaffold of random open and interconnected pores that is an engineered model based on the porous network of trabecular bone. Referring again to FIG 9, in the middle panel is a fixation implant 900' that is a variation of the fixation implant 900 shown above, wherein the shank 930 includes threading 940 along its length and only a portion of the length of the shank 930 is formed of the open scaffold body 950 and a portion of the shank 930 is solid. Referring to the bottom image of FIG 9, the depicted embodiment is a non-cannulated fixation implant 1000 having exterior threading 1040 and a porous body 1050 comprising a framework of random open and interconnected pores that closely mimics the porous network of trabecular bone.

[048] In accordance with various embodiments, the open and porous open core of the fixation implant may be formed by any of a variety of processes, including additive (3D) manufacturing, conventional machining, and assembly of subparts. And in some embodiments, the open and porous open core of one or both the head and the shank are formed separately, wherein any threads on the fixation implant are formed from a material selected from metal, and the open core is separately formed using composite material that includes one or more of biocompatible polymers such as PEK, PEEK and PAEK, and other biodegradable polymers, bone material, BMP, and the like.

[049] In some representative embodiments the fixation implant is or resembles a bone screw insofar as such fixation member includes a head and an elongated shank that includes a

threaded portion, and in some embodiments, a shank portion that is proximate to the head that is not threaded. It will be appreciated that such fixation members may comprise one or more different thread features that may vary in any one or more number of threads, frequency, pitch, helix angle, thread angle, and major and minor diameters. And the threading may be male (extending away from the fixation implant), female (notches, grooves or channels cut into the fixation implant for receiving male threads), and combinations of these. Further, any one or more of the thread features may be shaped as known in the art, including shapes selected from “V” shaped, square-, buttress-, reverse buttress threaded, and combinations of these, and the thread features may be left or right hand oriented, and the thread features may be self-cutting or self-tapping, or non-self-cutting or non-self-tapping, and combinations of these. Further, the threading may be present only on the shank, or may be present on the shank and one or more of at least a portion of the head and the distal tip. As described variously herein, a fixation member having external threading may alternately be referred to as a screw.

[050] In yet other representative embodiments, the fixation implant is or resembles a bone anchor or plug insofar as such fixation member includes a head and an elongated shank that is only partially threaded. It will be appreciated that in some such embodiments, such fixation members may comprise one or more surface features for enhancing engagement with tissue such as cortical or cancellous bone, such features including but not limited to, keels, fins, and distal bulbs or protuberances. In some embodiments, the fixation implant may have a surface treatment that is suitable for osseous-induction and may be one or more of porous and comprise an osseous-inductive agent, including a biological agent.

[051] In accordance with some embodiments the fixation member has an overall cylindrical, conical, or frusto conical shape that has either a fixed or an increasing diameter from distal to proximal. In some specific embodiments, the head has a frusto conical or a spherical or hemispherical shape. And in some embodiments, the shank has an overall or generally cylindrical shape, with a tapered or conical distal tip. In various embodiments, the fixation member may have a shank that is fully threaded, or it may have a short-unthreaded portion.

[052] As used herein, the term “head” in reference to the proximal head portion of the fixation implant means and includes a structure that is selected from spherical, shaped (e.g.,

generally spherical with one or more flats), hemi-spherical, frustoconical, discoid, and planar. Thus, in various embodiments with respect to the head, the fixation implant may resemble one of a conventional bone screw, a pedicle screw, a headless screw and other forms, wherein in each instance the head portion of the fixation implant is adapted with at least one feature for facilitating its insertion into bone. In accordance with some embodiments, a fixation member has a head that comprises a flat surface or top and may further comprise an enlarged outer diameter relative to the outer diameter of the shank, wherein the head may include an internal bore with one or more internal engagement features for receiving a driver. Such features may include one or more of a hex configuration for receiving a hex driver, or internal threading for receiving a threaded driver cap, or any of a variety of other possible engagement features. The head and shank of the fixation member, and any threaded driver cap may, in some embodiments, be cannulated for receiving a guide or k-wire there through.

[053] Further still, in some embodiments, the fixation member may be cannulated, in some embodiments only a portion of the fixation member may be cannulated, and in some embodiments the fixation member is not cannulated.

[054] In some such embodiments, the shape of the fixation member may be other than circular in cross section across the elongate axis, and thus the fixation member may have any one of a non-circular shape including ovoid and triangular. In some embodiments, all or only a portion of a fixation member may be circular in cross section and all or other portions of a fixation member may have a cross section that is other than circular, including ovoid and triangular. In some exemplary embodiments, a fixation member may have a frustoconical tip and a proximal adjacent portion that is triangular in cross section such that the tip can be pushed in to a bone hole. Further still, in some embodiments, the fixation member may have the same diameters shared for each of the head, shank and tip.

[055] While various inventive aspects, concepts and features of the general inventive concepts are described and illustrated herein in the context of various exemplary embodiments, these various aspects, concepts and features may be used in many alternative embodiments, either individually or in various combinations and sub-combinations thereof. Unless expressly excluded herein all such combinations and sub-combinations are intended to be within the scope

of the general inventive concepts. Still further, while various alternative embodiments as to the various aspects, concepts and features of the inventions (such as alternative materials, structures, configurations, methods, devices and components, alternatives as to form, fit and function, and so on) may be described herein, such descriptions are not intended to be a complete or exhaustive list of available alternative embodiments, whether presently known or later developed.

[056] Those skilled in the art may readily adopt one or more of the inventive aspects, concepts and features into additional embodiments and uses within the scope of the general inventive concepts, even if such embodiments are not expressly disclosed herein. Additionally, even though some features, concepts and aspects of the inventions may be described herein as being a preferred arrangement or method, such description is not intended to suggest that such feature is required or necessary unless expressly so stated. Still further, exemplary or representative values and ranges may be included to assist in understanding the present disclosure; however, such values and ranges are not to be construed in a limiting sense and are intended to be critical values or ranges only if so expressly stated.

[057] Moreover, while various aspects, features and concepts may be expressly identified herein as being inventive or forming part of an invention, such identification is not intended to be exclusive, but rather there may be inventive aspects, concepts and features that are fully described herein without being expressly identified as such or as part of a specific invention. Descriptions of exemplary methods or processes are not limited to inclusion of all steps as being required in all cases, nor is the order that the steps are presented to be construed as required or necessary unless expressly so stated.

What is claimed is:

1. A fixation implant comprising:
a shank having a length from a proximal end to a distal end; a head that is integral with the shank at its proximal end; a tip that is integral with the shank at its distal end; and at least one thread along at least a portion of a surface from and including the proximal head to the distal tip,
the fixation implant further comprising an open core comprising one or more open network bodies along at least a portion of at least the shank, wherein the at least one thread is integral with a surface of the open network body.
2. A fixation implant according to claim 1, wherein the one or more open network bodies is open in gaps between the at least one thread.
3. A fixation implant according to claim 1, wherein the open network body is selected from the group including: a helix; an organized arrangement of trusses; a random arrangement of trusses; a scaffold of open and interconnected pores; and, a porous framework of random open and interconnected pores; and combinations thereof.
4. A fixation implant according to claim 1, wherein the implant includes along at least a portion of the shank a void within the open network body.
5. A fixation implant according to claim 4, wherein the implant comprises within the open network body a through cannula along a length from and including the proximal head, the shank and the distal tip.
6. A fixation implant according to claim 5, further comprising a wall around the cannula within the open network body.
7. A fixation implant according to claim 6, wherein the wall is one of solid and fenestrated.
8. A fixation implant according to claim 4, further comprising a wall around the void within the open network body.
9. A fixation implant according to claim 9, wherein the wall is solid.
10. A fixation implant according to claim 9, wherein the wall is fenestrated.

11. A fixation implant according to claim 1, wherein one or more surfaces of fixation implant is provided with a surface treatment that is one of porous and osseointegrative.
12. A fixation implant according to claim 1, wherein the open network body is formed by a process selected from additive (3D) manufacturing, conventional machining, and assembly of subparts.
13. A fixation implant according to claim 1, one or both the head and the shank are formed separately, wherein threads on the fixation implant are formed from a material selected from metal, and the open network body is separately formed using composite material that includes one or more of biocompatible polymers selected from PEK, PEEK, PAEK, and biodegradable polymers, bone material, BMP, and combinations of these.
14. A fixation implant comprising a head, a shank and a distal tip, wherein the head has a cannulated core that is a solid and selected from a metal and a polymer, and wherein the shank comprises (i) adjacent to the head, a proximal shank portion that is non-threaded and has a solid cannulated core selected from metal and a polymer; (ii) a tapered distal tip portion that has a solid cannulated core selected from metal and a polymer and comprise external threads along at least a portion of its surface; and (iii) a threaded ingrowth portion extending from the non-threaded proximal shank portion to the tapered distal tip and comprising external threads, the open network body extending along the length of the ingrowth portion and selected from one or a combination of: at least one helix, an organized arrangement of trusses, a random arrangement of trusses, a scaffold of open and interconnected pores, a porous framework of random open and interconnected pores, and combinations of these.
15. A fixation implant according to claim 14, wherein the open body network comprises a scaffold of open and interconnected pores, and wherein the shank and a portion of the distal tip are threaded and the implant is formed of a material comprising metal.
16. A fixation implant comprising:
a shank having a length from a proximal end to a distal end; a head that is integral with the shank at its proximal end; a tip that is integral with the shank at its distal end; and at least one thread along at least a portion of a surface from and including the proximal head

to the distal tip,

the fixation implant further comprising an open core comprising one or more open network bodies along at least a portion of at least the shank, wherein the at least one thread is integral with a surface of the open network body, wherein the one or more open network bodies is open in gaps between the at least one thread, and wherein the open network body is selected from the group including: a helix; an organized arrangement of trusses; a random arrangement of trusses; a scaffold of open and interconnected pores; and, a porous framework of random open and interconnected pores; and combinations thereof.

17. A fixation implant according to claim 16, wherein the implant includes along at least a portion of the shank a void within the open network body.
18. A fixation implant according to claim 17, wherein the implant comprises within the open network body a through cannula along a length from and including the proximal head, the shank and the distal tip.
19. A fixation implant according to claim 18, further comprising a wall around the cannula within the open network body.
20. A fixation implant according to claim 19, wherein the open network body is formed by a process selected from additive (3D) manufacturing, conventional machining, and assembly of subparts, and wherein one or both the head and the shank are formed separately, wherein threads on the fixation implant are formed from a material selected from metal, and the open network body is separately formed using composite material that includes one or more of biocompatible polymers selected from PEK, PEEK, PAEK, and biodegradable polymers, bone material, BMP, and combinations of these.

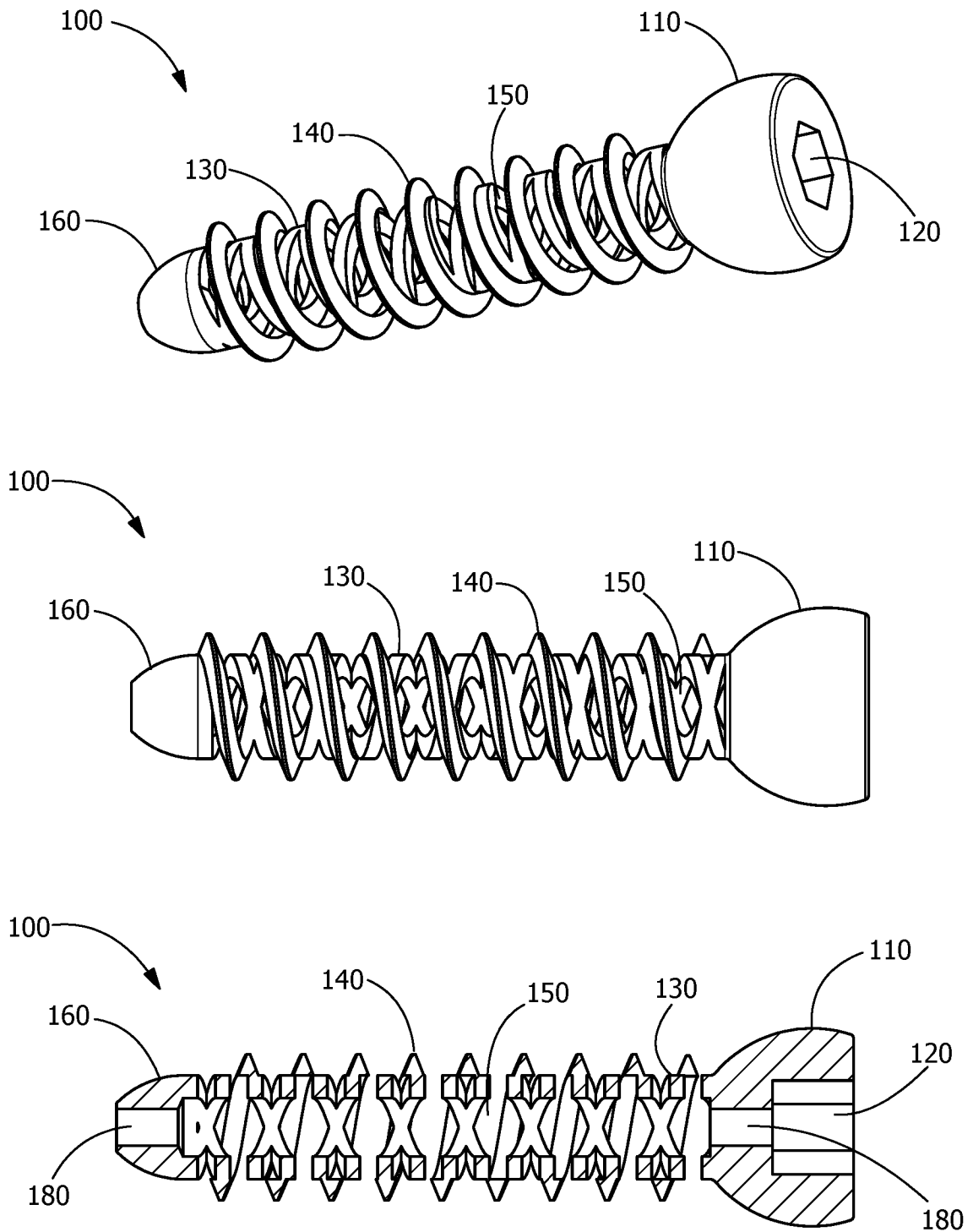

FIG. 1

2/9

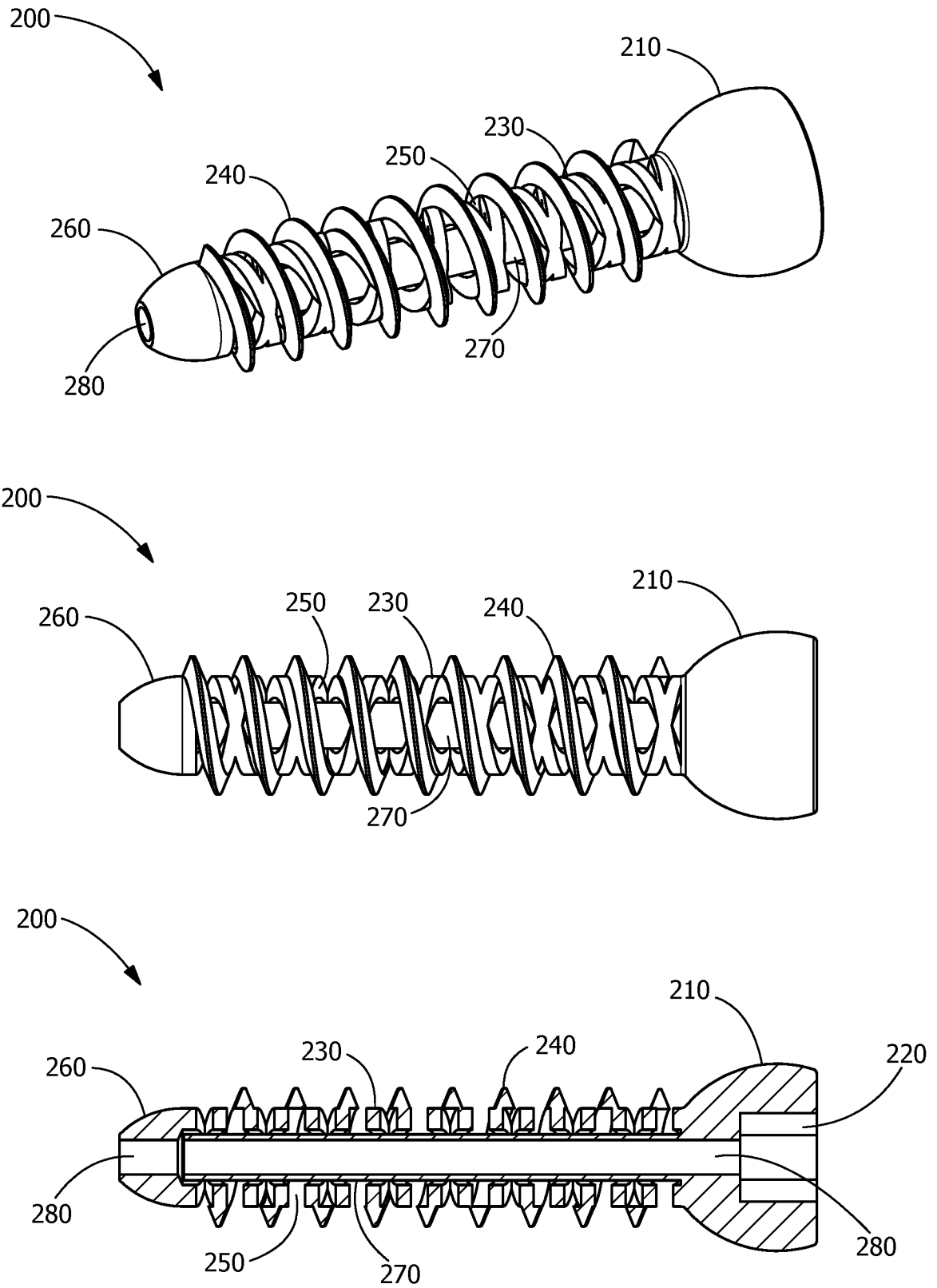

FIG. 2

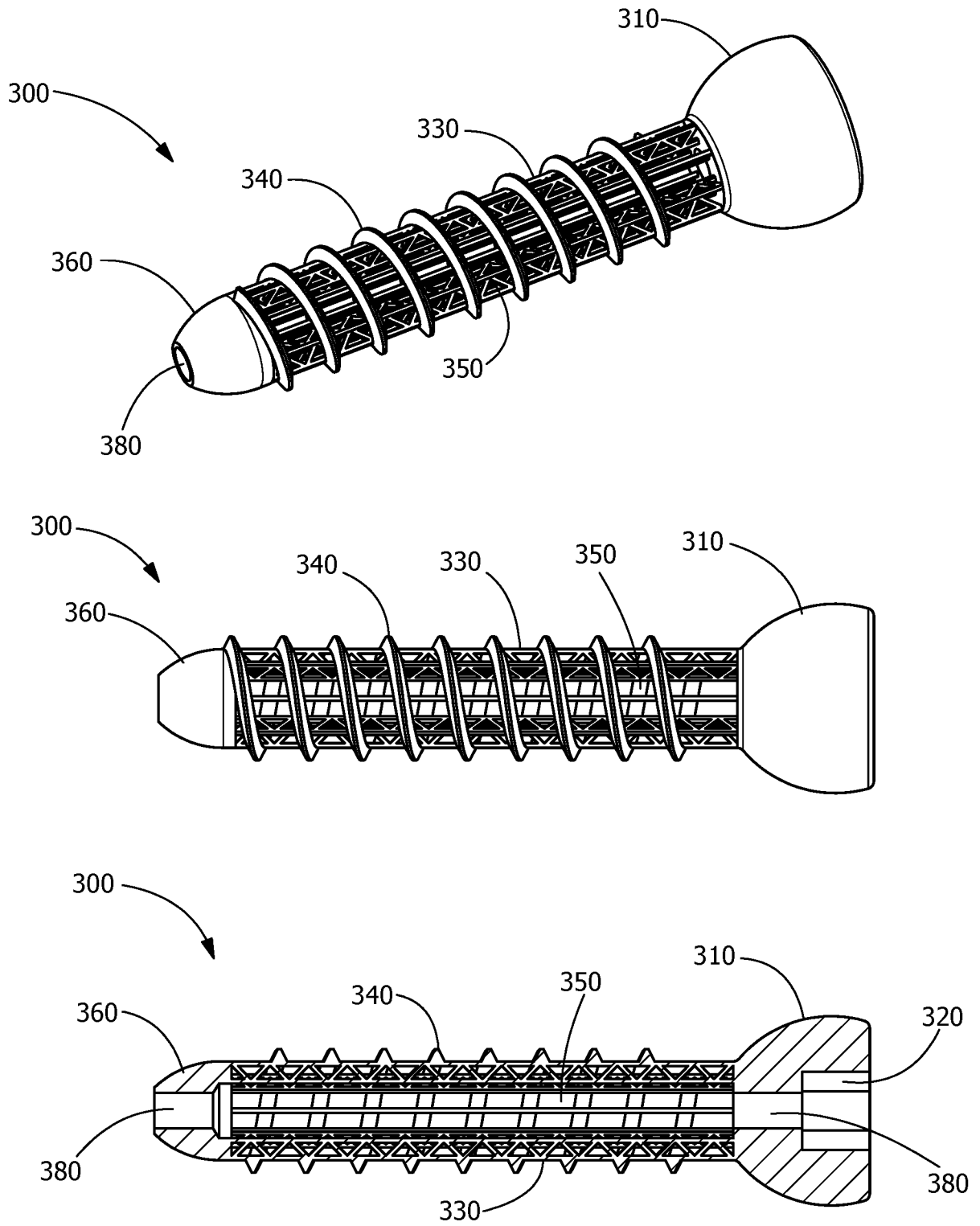

FIG. 3

4/9

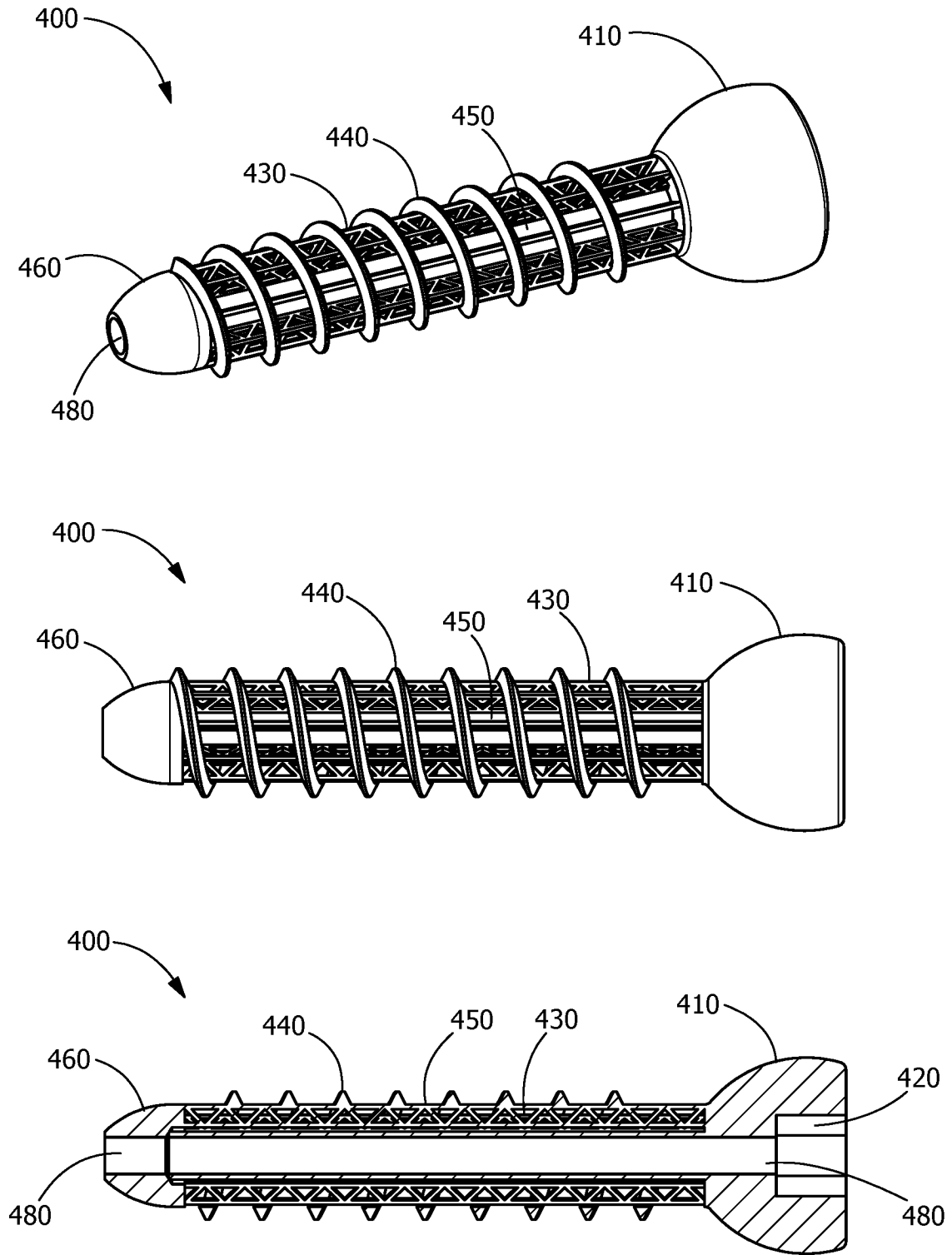

FIG. 4

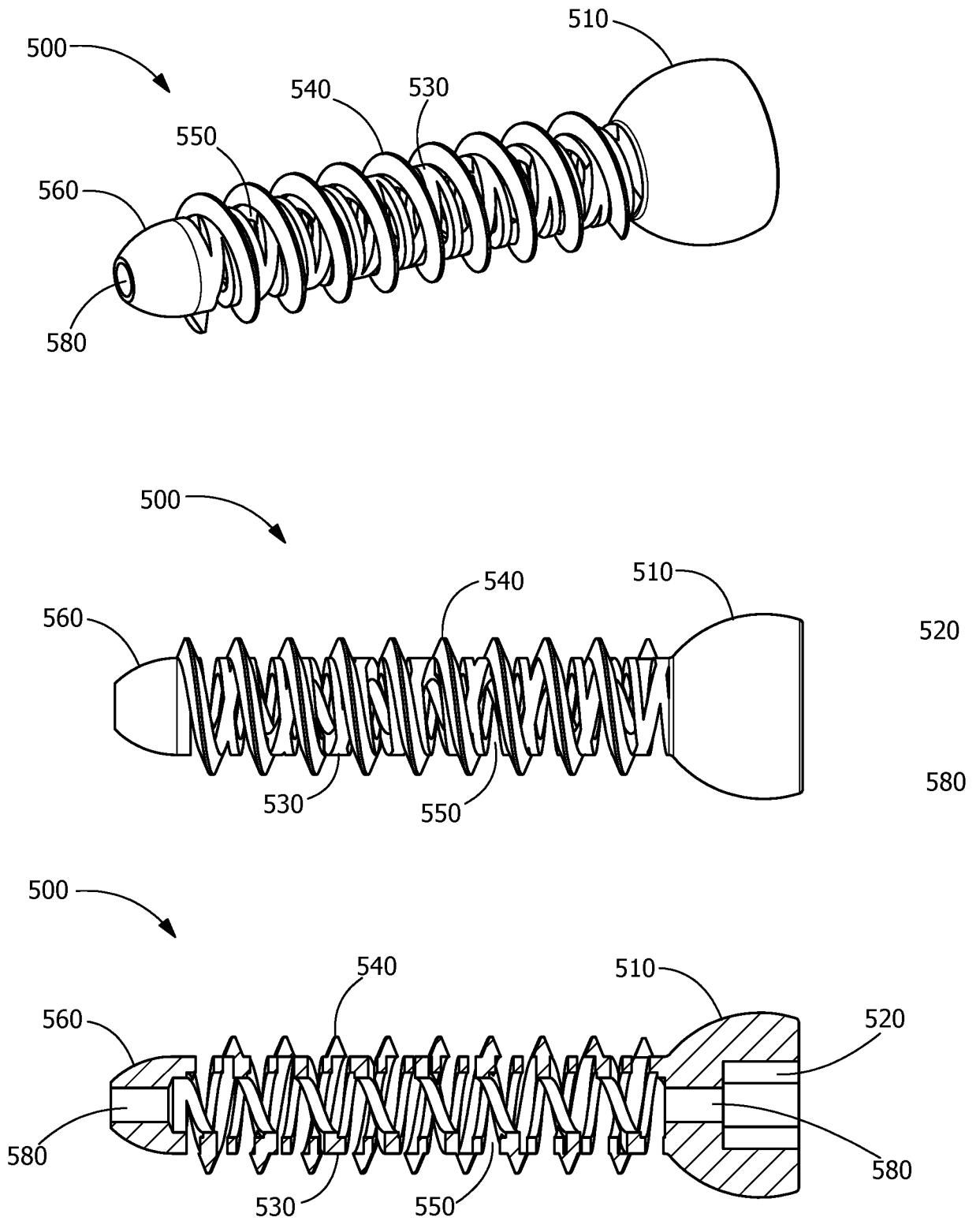

FIG. 5

6/9

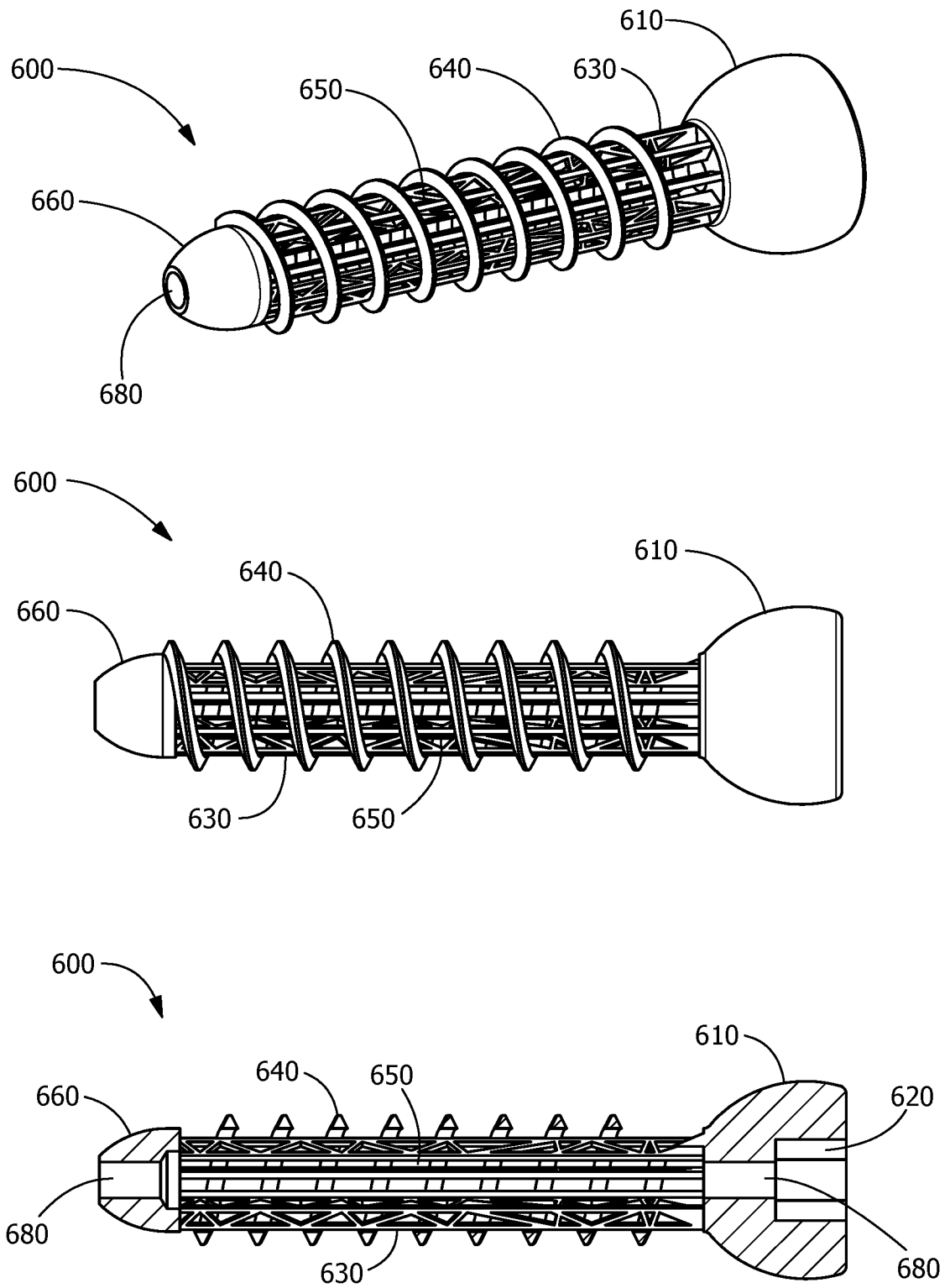

FIG. 6

7/9

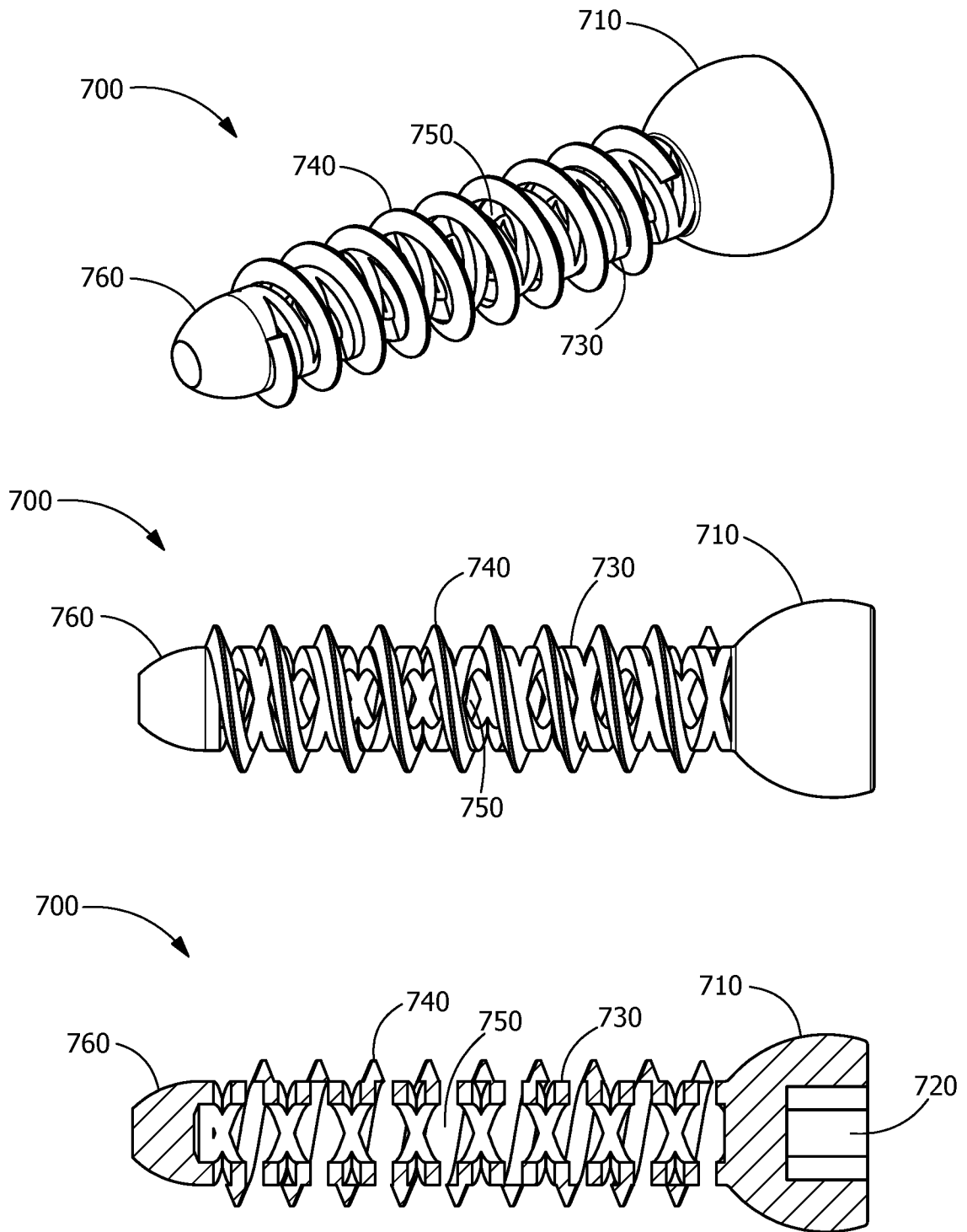

FIG. 7

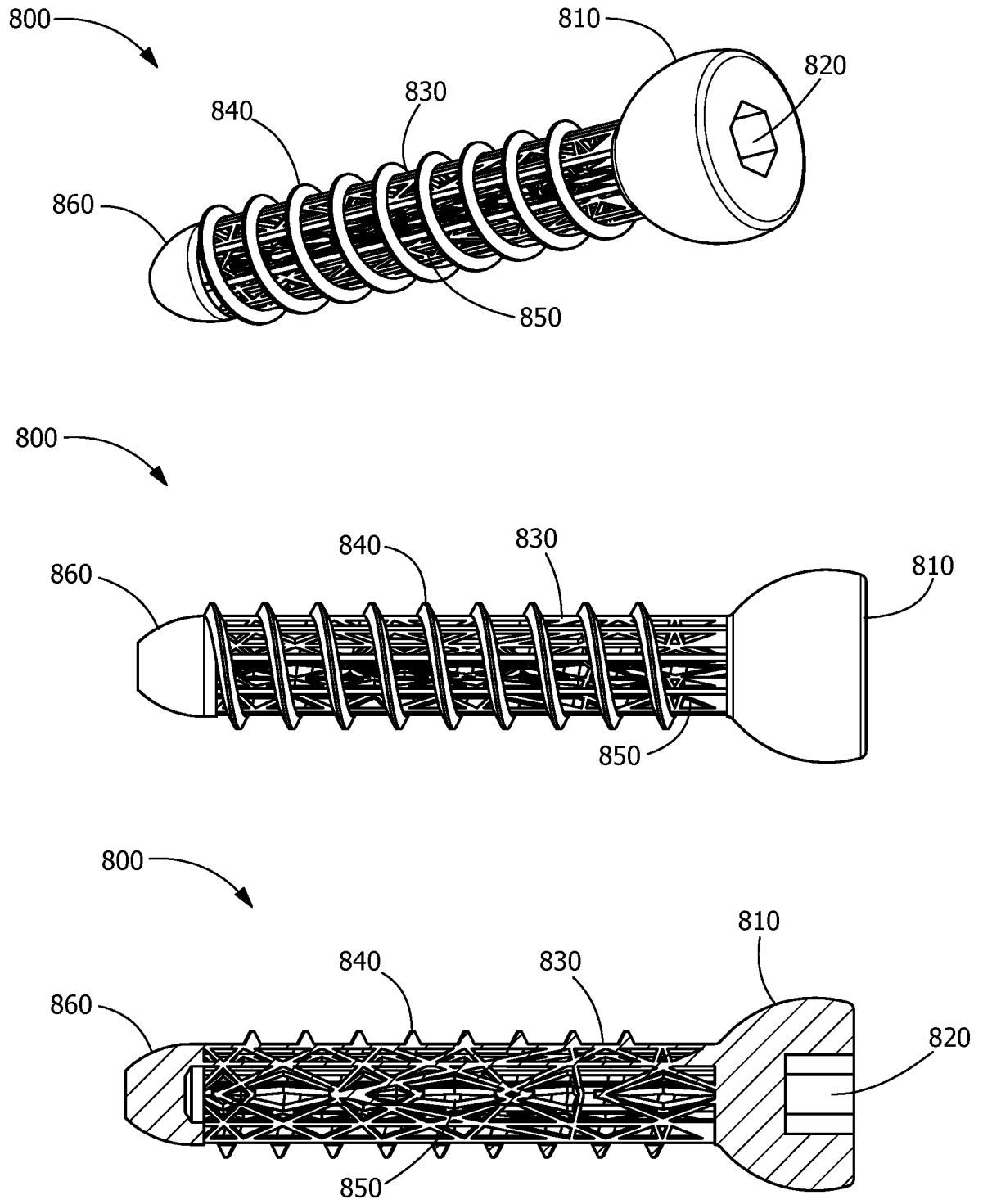

FIG. 8

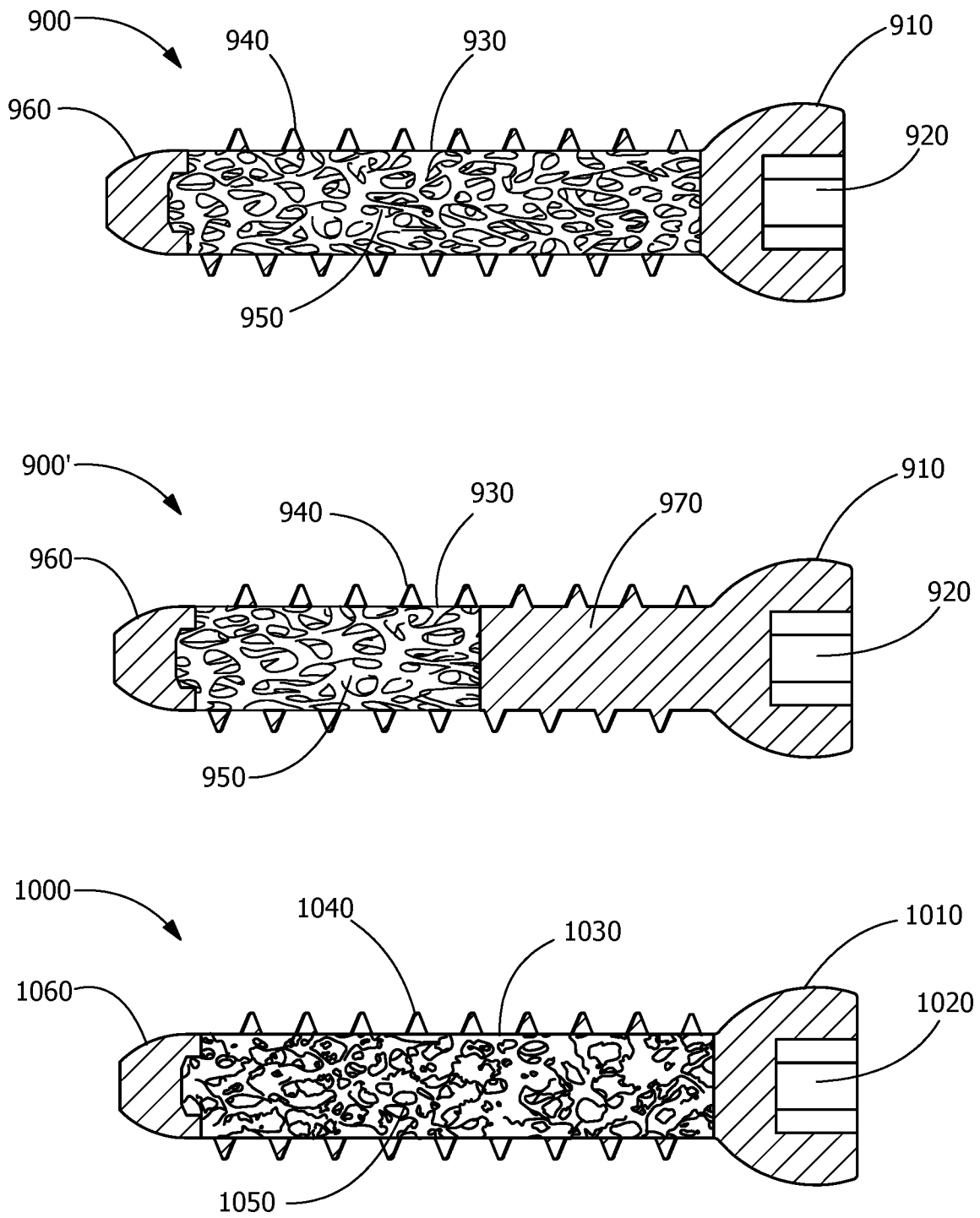

FIG. 9

INTERNATIONAL SEARCH REPORT

International application No.

PCT/US 2018/032215

| A. CLASSIFICATION OF SUBJECT MATTER | | |
|---|---|--|
| <i>A61F 2/30 (2006.01)</i> <i>A61L 2/58 (2006.01)</i> <i>A61L 27/40 (2006.01)</i> | | |
| According to International Patent Classification (IPC) or to both national classification and IPC | | |
| B. FIELDS SEARCHED | | |
| Minimum documentation searched (classification system followed by classification symbols) | | |
| A61F 2/00, 2/30, A61L 2/00, 2/58, 27/00, 27/40 | | |
| Documentation searched other than minimum documentation to the extent that such documents are included in the fields searched | | |
| Electronic data base consulted during the international search (name of data base and, where practicable, search terms used) | | |
| PatSearch (RUPTO internal), Esp@cenet, PAJ, USPTO, Information Retrieval System of FIPS | | |
| C. DOCUMENTS CONSIDERED TO BE RELEVANT | | |
| Category* | Citation of document, with indication, where appropriate, of the relevant passages | Relevant to claim No. |
| A | US 9179954 B2 (VIVEX BIOMEDICAL, INC.) 10.11.2015 | 1-20 |
| A | US 5282861 A (ULTRAMET) 01.02.1994 | 1-20 |
| A | RU 2172146 C1 (MOSKOVSKAYA MEDITSINSKAYA AKADEMIYA IM. I.M. SECHENOVA et al.) 20.08.2001 | 1-20 |
| A | RU 2150964 C1 (ROSSIYSKIY NAUCHNO-ISSLEDOVATELSKIY INSTITUT TRAVMATOLOGII I ORTOPEDII IM. R.R. VREDENA) 20.06.2000 | 1-20 |
| <input type="checkbox"/> Further documents are listed in the continuation of Box C. <input type="checkbox"/> See patent family annex. | | |
| * Special categories of cited documents: | | |
| “A” | document defining the general state of the art which is not considered to be of particular relevance | “T” later document published after the international filing date or priority date and not in conflict with the application but cited to understand the principle or theory underlying the invention |
| “E” | earlier document but published on or after the international filing date | “X” document of particular relevance; the claimed invention cannot be considered novel or cannot be considered to involve an inventive step when the document is taken alone |
| “L” | document which may throw doubts on priority claim(s) or which is cited to establish the publication date of another citation or other special reason (as specified) | “Y” document of particular relevance; the claimed invention cannot be considered to involve an inventive step when the document is combined with one or more other such documents, such combination being obvious to a person skilled in the art |
| “O” | document referring to an oral disclosure, use, exhibition or other means | “&” document member of the same patent family |
| “P” | document published prior to the international filing date but later than the priority date claimed | |
| Date of the actual completion of the international search | | Date of mailing of the international search report |
| 07 August 2018 (07.08.2018) | | 06 September 2018 (06.09.2018) |
| Name and mailing address of the ISA/RU: Federal Institute of Industrial Property, Berezhkovskaya nab., 30-1, Moscow, G-59, GSP-3, Russia, 125993 Facsimile No: (8-495) 531-63-18, (8-499) 243-33-37 | | Authorized officer M. Masalova Telephone No. (495)531-64-81 |