

Jan. 4, 1938.

O. S. RAINER

2,104,672

AUTOMATIC LIQUID FEED FOR STORAGE BATTERIES

Filed Feb. 8, 1937

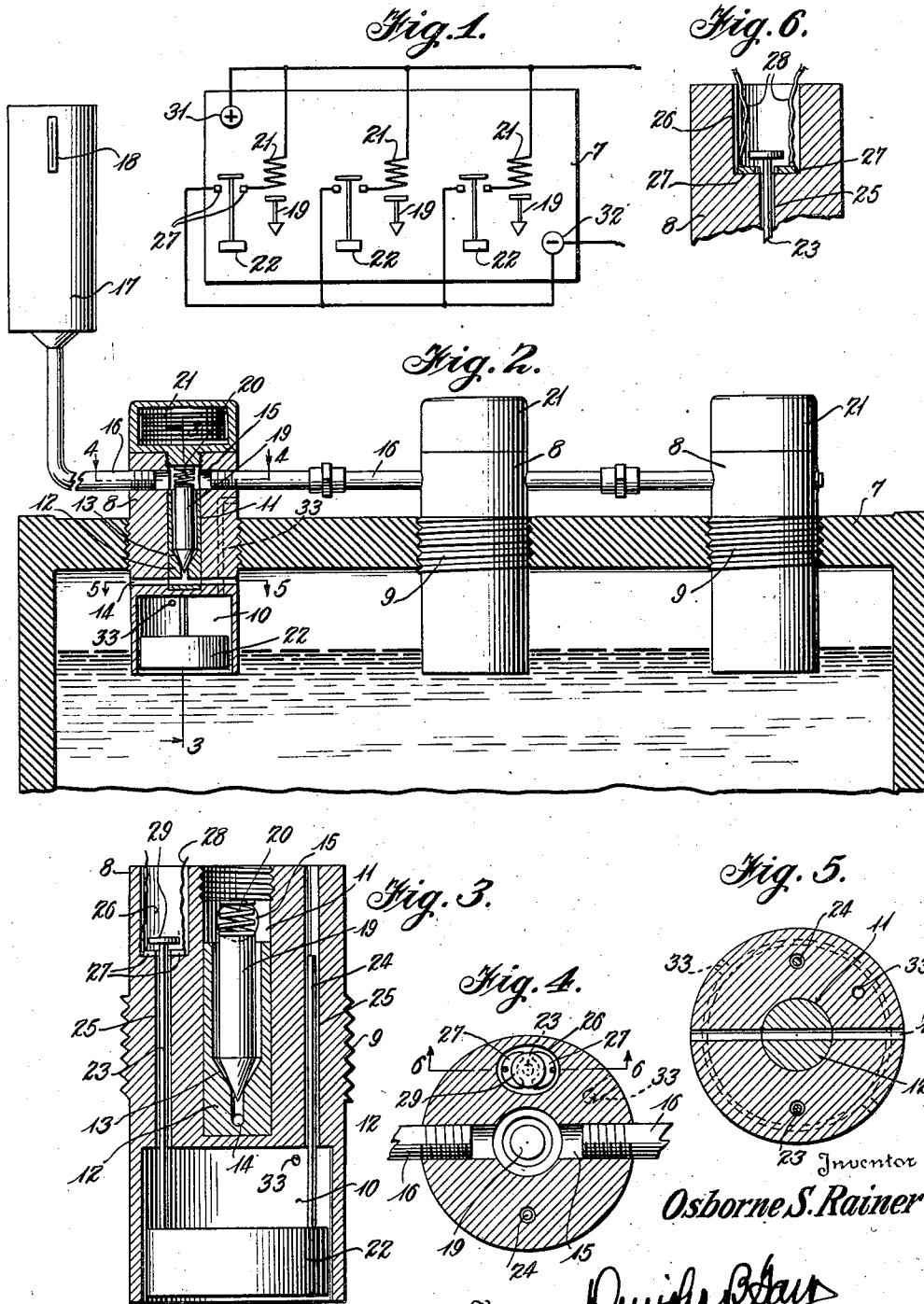

23 Inventor  
**Osborne S. Rainer**

*Osborne S. Rainer*  
Attorney

# UNITED STATES PATENT OFFICE

2,104,672

## AUTOMATIC LIQUID FEED FOR STORAGE BATTERIES

Osborne S. Rainer, Montgomery, Ala.

Application February 8, 1937, Serial No. 124,758

3 Claims. (Cl. 137—68)

This invention relates to automatic liquid feeding devices for use in connection with storage batteries, aiming primarily to provide means whereby the required liquid level in each cell of the battery is at all times maintained, and which eliminates the effort and time heretofore involved in the removal of automobile floor boards and filling caps for the purpose of replenishing the supply of liquid to the battery.

A further object of the invention is to provide an automatic filling device of such character and construction as to be readily applicable to batteries now in use and not requiring batteries or cells of specific type or character for its application.

A further object of the invention is to provide an automatic liquid supply device which is of extremely simple construction, which comprises few inexpensive and readily assembled parts, which may be readily installed upon automobiles, motor boats, airplanes or other apparatus employing the ordinary storage battery without the exercise of special skill and knowledge, which will prove thoroughly reliable and efficient in use, which has its parts so constructed and assembled as to minimize the opportunity for wear, breakage or derangement and which may be manufactured, installed and maintained at a minimum of expense.

With these objects in view, together with others which will appear as the description proceeds, the invention consists in the novel construction, combination and arrangement of parts, all as will be described more fully hereinafter, illustrated in the drawing and particularly pointed out in the claims.

In the drawing:

Figure 1 is a diagrammatic view illustrating a conventional form of storage battery and showing a wiring diagram which may be employed in carrying out the invention.

Figure 2 is an enlarged fragmentary sectional view taken longitudinally through the storage battery and illustrating as applied thereto an automatic filling device embodying the invention.

Figure 3 is an enlarged sectional view taken substantially upon the line 3—3 of Figure 2.

Figure 4 is a transverse sectional view taken upon line 4—4 of Figure 2.

Figure 5 is a similar view taken upon line 5—5 of Figure 2, and

Figure 6 is an enlarged fragmentary section taken upon line 6—6 of Figure 4.

The invention consists generally in the provision of a water feed device for each cell of the

battery, which devices are supplied from a common source or reservoir capable of being conveniently refilled from time to time and so positioned as to be easily observed to determine the quantity of liquid contained in the reservoir. Each of the automatic feed devices are so constructed as to be applicable to the water feed openings of the battery cells, and each has associated therewith float and valve mechanism which operate when the liquid level in the cell drops below a predetermined point to open the valve and allow a fresh supply of liquid to flow into the cell until the proper level has been reached, whereupon the supply is automatically shut off. Each of the cells is equipped with such an automatic feed in order that the liquid level in such cells may be at all times accurately governed. Such of the parts of the apparatus as require may be constructed of such material or may be so treated as to resist acid attack or corrosion thereby insuring proper operation of such parts at all times.

Referring now more particularly to the drawing, 7 indicates the casing or shell of a familiar type of storage battery, involving in this instance three cells as shown. The usual filling caps for these cells are removed and automatic feed devices of my invention are inserted in their places, as will be understood. As the several feed devices are identical in construction, but one will be described in the present specification.

The automatic filling device includes a plug 8 preferably of cylindrical shape of an exterior diameter corresponding substantially to the diameter of the cell opening, having exterior threads 9 as shown to engage corresponding threads in the cell opening. It will be understood that the plugs fit within these openings in liquid tight manner so as to obviate leakage. The plug is recessed at its inner or lower end as at 10 to provide a cup or cage, while the said plug is provided with a central or axial bore or port 11 provided with a valve liner 12 having a conical seat 13 near its lower end. This port is in communication with laterally directed channels or openings 14 so that liquid flowing down through the port may enter the battery cells from opposite sides of the plug.

The plug is equipped near its outer or upper end with a diametrically disposed opening 15 which intersects the port 11, and into which may be threaded the ends of a liquid duct 16 connected with a tank or reservoir 17 having a sight gage 18 to determine the quantity of liquid within

the tank. This tank may be located within the vehicle or beneath the hood or in any desired place for convenient observation and refilling. As shown particularly in Figure 2 of the drawing, the pipes 16 lead from one to the other of the several cell refilling devices in order that all may be supplied from a common source.

The central port 11 is provided with a plunger or valve stem 19 mounted for reciprocation within the said port and provided with a conical end as shown for engagement with the valve seat 13. A spring 20 cooperates with the stem to normally maintain the same in closed or seated position.

Mounted upon the upper end of the plug 8 and within a suitable casing is a solenoid or electro-magnet 21, adapted when excited or energized to operate upon the stem 19 to withdraw the same from the seat 13 and permit the passage of liquid through the port and to the interior of the battery cell. When the magnet is deenergized the spring 20 forces the stem back to closed position.

The cage 10 at the lower end of the plug houses a float 22, from opposite points of which project upwardly extending rods or arms 23-24 passing through opening 25 disposed longitudinally through the plug. These arms or rods serve as stabilizers for the float, and the rod 23 further carries means whereby a circuit through the electro-magnet 21 may be automatically closed when the float reaches a predetermined low position. The upper part of the opening 25 which houses the stem 23 is enlarged or recessed as at 26 to provide a chamber for the accommodation of the circuit closing mechanism. This mechanism includes a pair of contact members 27 insulated from each other and to which the terminals or wires 28 of an electric circuit are connected. The upper end of the rod or arm 23 is provided with a head 29 to bridge the contacts 27 whereby the circuit will be closed when the head drops down and into engagement with the said contacts.

The electric circuit by means of which the invention may be carried out is disclosed in Figure 1, where the positive side is connected with the post 31 and the negative with the post 32. Branch wires lead from the positive through the solenoid and to one of the contacts 27, while the negative is connected by suitable leads to the opposite contact 27.

From the foregoing it is apparent that when the liquid level in any one of the cells drops so low that the head 29 bridges contacts 27, the electro-magnet of that cell will at once be energized, will attract the core or stem 19 and lift the valve from its seat, whereupon liquid will gravitate from tank 17 through pipes 16 and into the cell through the ports 14. Any air which may be trapped in the cell will escape through the vent 33 which establishes communication between the interior of the cage 10 and the exterior of the

plug. When the liquid in the cell reaches the proper or desired level, the float will lift the head 29 from engagement with contacts 27, whereupon the circuit through the solenoid will be broken and the valve stem 19 will descend and close the port.

It is obvious from this description that I have provided means of extremely simple construction for carrying out the objects of the invention. Reference has been made to detailed structure for the accomplishment of the several results, but it will be understood that variations in the mechanical refinements and arrangement of parts may be resorted to if desired without departing from the spirit of the invention as defined by the claims.

Having thus described my invention, what I claim as new and useful is:

1. A plug for engagement in the filling opening of a battery cell, a cage in the lower end of said plug, said plug having an axial bore, a valve seat near the lower end of said bore, a stem slidable in said bore and engageable with said seat, an electro-magnet on the upper end of said plug adapted when energized to lift said valve from said seat, a float in said cage, said plug having spaced openings disposed longitudinally thereof, arms on said float slidable in said openings, spaced contact members in one of said openings, a contact head connected to one of said arms and adapted to bridge said contact members when the float is in lowermost position, said members adapted to be included in an electric circuit with said magnet, and means whereby said bore may be supplied with liquid.

2. A plug for engagement in the filling opening of a battery cell, said plug having a bore, a valve seat in said bore, a valve stem in said plug and engageable with said seat, and electro-magnet adapted when energized to lift said valve from said seat, a float, said plug having spaced openings disposed longitudinally of said plug, arms on said float slidable in said openings, spaced contact members in one of said openings, a contact head on one of said arms adapted to bridge said contact members when the float is in lowermost position, said members adapted to be included in an electric circuit with said magnet, and means whereby said bore may be supplied with liquid.

3. A plug for engagement in the filling opening of a battery cell, said plug having a bore, means to supply liquid to said bore, a valve in said bore to govern the flow of liquid therethrough, a float carried by said plug, said plug having spaced openings, arms carried by said float and slidable in said openings, and means operable when one of said arms has reached a predetermined position in its opening to operate said valve.

OSBORNE S. RAINER.