

AUSTRALIA

Patents Act 1990

**NOTICE OF ENTITLEMENT**  
(To be filed before acceptance)

We, MEADOX MEDICALS, INC., of 112 Bauer Drive, Oakland, New Jersey 07436, United States of America, being the applicant in respect of Application No. 84379/91 state the following:-

MEADOX MEDICALS, INC., the person nominated for the grant of the patent has entitlement from the actual inventor Peter J. SCHMITT, 2 Bubenko Drive, Garnerville, New York 10923, New York, United States of America, by assignment.

The person nominated for the grant of the patent has entitlement from the applicant of the application listed in the declaration under Article 8 of the PCT by assignment.

The basic application listed on the request form is the first application made in a Convention country in respect of the invention.

MEADOX MEDICALS, INC.

By our/my Patent Attorneys,  
WATERMARK PATENT & TRADEMARK ATTORNEYS

  
.....  
L.J. Dyson  
Registered Patent Attorney

.....  
27 February 1995



**(12) PATENT ABRIDGMENT (11) Document No. AU-B-84379/91**  
**(10) AUSTRALIAN PATENT OFFICE (10) Acceptance No. 659097**

- (54) Title  
**SELF-SUPPORTING WOVEN VASCULAR GRAFT**
- International Patent Classification(s)  
 (51)<sup>5</sup> **A61F 002/06**
- (21) Application No. : **84379/91** (22) Application Date : **27.08.91**
- (87) PCT Publication Number : **WO92/03107**
- (30) Priority Data
- |               |                 |                                    |
|---------------|-----------------|------------------------------------|
| (31) Number   | (32) Date       | (33) Country                       |
| <b>573932</b> | <b>28.08.90</b> | <b>US UNITED STATES OF AMERICA</b> |
- (43) Publication Date : **17.03.92**
- (44) Publication Date of Accepted Application : **11.05.95**
- (71) Applicant(s)  
**MEADOX MEDICALS, INC.**
- (72) Inventor(s)  
**PETER J. SCHMITT**
- (74) Attorney or Agent  
**WATERMARK PATENT & TRADEMARK ATTORNEYS , Locked Bag 5, HAWTHORN VIC 3122**
- (56) Prior Art Documents  
**US 4892539**  
**US 4610688**  
**GB 820014**
- (57) Claim

1. A self-supporting tubular woven synthetic vascular graft including a filling yarn characterized by:

the filling yarn including a stiffening component to provide radial burst strength, dimensional stability and radial rigidity sufficient to maintain the lumen of the tubular structure open woven together throughout the length of the weave, and wherein said stiffening component is present in each pick of the weave.

35. A process of preparing a self-supporting woven <sup>synthetic</sup> vascular graft, comprising:

weaving a tube of a plurality of warp ends including multifilament yarns with a filling yarn of a stiffening component sufficient to render the graft self-supporting without crimping;

scouring said woven tube; and

heat setting the fabric.

OPI DATE 17/03/92 APPLN. ID 84379 / 91

AOJP DATE 30/04/92 PCT NUMBER PCT/US91/05907



INTERNATIONAL APPLICATION PUBLISHED UNDER THE PATENT COOPERATION TREATY (PCT)

<b>(51) International Patent Classification<sup>5</sup> :</b> A61F 2/06	<b>A1</b>	<b>(11) International Publication Number:</b> WO 92/03107 <b>(43) International Publication Date:</b> 5 March 1992 (05.03.92)
<b>(21) International Application Number:</b> PCT/US91/05907 <b>(22) International Filing Date:</b> 27 August 1991 (27.08.91) <b>(30) Priority data:</b> 573,932 28 August 1990 (28.08.90) US <b>(71) Applicant:</b> MEADOX MEDICALS, INC. [US/US]; 112 Bauer Drive, Oakland, NJ 07436 (US). <b>(72) Inventor:</b> SCHMITT, Peter, J. ; 2 Bubenko Drive, Garnerville, NY 10923 (US). <b>(74) Agents:</b> WOLFSON, Michael, I. et al. ; Blum Kaplan, 1120 Avenue of the Americas, New York, NY 10036 (US).	<b>(81) Designated States:</b> AT (European patent), AU, BE (European patent), CA, CH (European patent), DE (European patent), DK (European patent), ES (European patent), FR (European patent), GB (European patent), GR (European patent), IT (European patent), JP, LU (European patent), NL (European patent), SE (European patent). <b>Published</b> <i>With international search report. Before the expiration of the time limit for amending the claims and to be republished in the event of the receipt of amendments.</i>  <b>659097</b>	

**(54) Title:** SELF-SUPPORTING WOVEN VASCULAR GRAFT

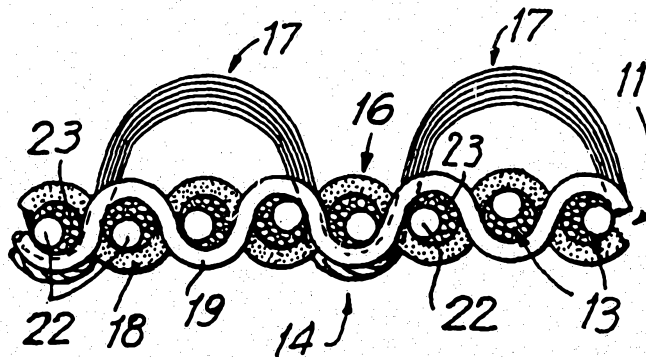

**(57) Abstract**

A woven synthetic fabric tubular vascular graft including a stiffening component in the filling yarn which is self supporting without crimping the walls of the graft. The graft is woven from warp ends of multifilament polyester yarns and elastomeric yarns and a filling yarn which includes multifilament and monofilament polyester yarns which have been twisted together. Longitudinal and radial compliance provides for improved kink resistance making the tubular grafts suitable for use in medium and small diameter peripheral applications. A preferred graft has a velour outer surface and a smooth inner surface.

**SELF-SUPPORTING WOVEN VASCULAR GRAFT****BACKGROUND OF THE INVENTION**

This invention relates to synthetic vascular grafts, and more particularly to synthetic woven vascular grafts including a stiffening component to provide a non-crimped self-supporting graft.

Vascular grafts of synthetic materials are widely used for the replacement of segments of human blood vessels. Synthetic vascular grafts have taken a wide variety of configurations and are formed of a wide variety of materials. Among the accepted and successful vascular graft implants are those formed from a biologically compatible material in tubular form which retain an open lumen to permit blood to flow normally through the graft after implantation. The biologically compatible materials include thermoplastic materials such as polyester, polytetrafluoroethylene (PTFE), silicone and polyurethanes. The most widely used are polyester fibers and PTFE. The polyester fibers, usually Dacron, may be knit or woven and may be of a monofilament, multifilament or staple yarn, or combination of each.

There are a wide variety of synthetic vascular grafts presently in use. An important factor in the selection of a particular graft is the porosity of the substrate of which the graft is formed, the resiliency of the tubular construction and the strength requirements for the implant. Porosity is significant, because it controls the tendency to hemorrhage during and after implantation and influences ingrowth of tissue into the wall of the graft.

Synthetic fabric vascular grafts may be of a woven, knitted with or without a velour construction. A synthetic vascular graft having a warp-knit construction is disclosed by William J. Liebig in U.S. Patent No. 3,945,052. Another graft having a warp knit double-velour construction is described by Liebig and German Rodriguez in U.S. Patent No. 4,047,252. William J. Liebig and Dennis Cummings describe a synthetic woven double-velour graft in U.S. Patent No. 4,517,687; the velour loops being formed of warp yarns which are texturized preshrunk multifilament yarns. These three issued United

States patents for synthetic vascular grafts are assigned to the assignee of this application.

U.S. Patent No. 4,892,539 issued to Durmus Koch describes a synthetic fabric woven graft with a single velour on the outer surface. The graft is described as woven from multifilament polyester yarns, specifically described as texturized, with the single outer velour formed of filling yarns with each velour loop extending outside a plurality of warp yarns.

After knitting or weaving multifilament yarns into tubular forms, the grafts are compacted by a method such as disclosed in U.S. Patents No. 3,853,462 to Ray E. Smith and No. 3,986,828 to Harmon Hoffman and Jacob Tolsma also assigned to the same assignee as this application. Compaction results in shrinking of the yarns and generally reduces the overall porosity of the fabric substrate. These tubular grafts after compacting generally have a diameter from about 6 mm to 40 mm.

Subsequent to compacting, synthetic tubular fabric grafts are crimped. Crimping involves forming ridges in the wall of the grafts to eliminate the danger of kinking or collapse of the tubing when flexed and results in uniform, regular, circular corrugations which maintains uniform strength over the entire surface of the graft tubing. This applies to both the woven and knit fabric vascular grafts. Examples are shown by L. R. Sauvage in U.S. Patent No. 3,878,565 who describes a tubular textile synthetic fiber prosthesis of a body having a multiplicity of outwardly extending fiber loops. In FIG. 2a, the graft body is crimped into irregular, circumferential corrugations. The degree of protection afforded by irregular corrugation varies over the lengths of the tube and can fall below the required level of protection at specific regions. The warp-knit and woven grafts described above in U.S. Patent No. 3,945,052, No. 4,047,252 and 4,517,687 are circularly crimped. The graft in U.S. Patent No. 4,892,539 is crimped in a spiral fashion. Crimped or corrugated walls can disrupt blood flow and create areas of thick tissue buildup, due to the profile.

S. Polansky in U.S. Patent No. 3,304,557 avoids crimping in vascular prosthesis by forming a tube with repeating reinforcing ring sections. These reinforcing ring sections incorporate reinforcing picks adjacent only the outer surface. He proposes that the annular rings can be in the form of a helix, alternating rings and helix-loops. These latter suggestions are similar to the tubular prosthesis of I. B. Medell in U.S. Patent No. 3,479,670 wherein an open mesh tube is wrapped with two polypropylene monofilament right-hand and left-hand helices and fused to penetrate partially the exterior of the tube. In U.S. Patent No. 3,272,204 to C. Artandi and L. D. Bechtol sew a Dacron fabric to Teflon rings or a helix to prevent an absorbable collagen reinforced graft tube from collapsing.

If U.K. Patent No. 820,014 shows a self-supporting woven tubular fabric graft woven from tube filling (or weft) yarns. One weft is a monofilament nylon or other man-made fiber covered with a yarn of nylon or other man-made fiber and a second weft yarn of fine nylon or other man-made fiber to separate the coils of the first weft yarn to enable the fabric to be bent without the formation of kinks. The specification further describes that the fabric is woven on a narrow fabric loom with two shuttles which carry the two different types of weft yarns. The fine weft yarn is described as allowing the monofilament to bend so that the monofilament coils can come together on the inside edge and to open on the outside edge. This is taught as critical to allow the tube to be bent in an arc without the inside board being obstructed by a kink which would ensue by normal tubular construction or weave.

Selection of a particular type of graft substrate by a vascular surgeon depends upon several factors. Among the factors included is the particular location of the implantation. This also dictates the size of the graft in order to maintain a sufficiently large or small lumen to accommodate normal blood flow in the region of implantation. The ultimate strength requirements and blood pressure in the location of implantation also affect the selection. Generally,



the woven grafts provide greater strength and reduced porosity, but are generally considered to be more difficult to handle and suture. Velours are often preferred because the velour surfaces facilitate growth of tissue into the loops extending from the surface of the velour fabric. The knitted grafts are generally softer and more easily sutured, but are generally more porous. Depending on the location of the implant and heparinization condition of the patient, synthetic fabric grafts generally must be preclotted with the patients blood before implantation. Preclotting may not be essential with a woven graft, but is generally recommended nonetheless.

Tubular grafts of smaller diameter, for example, 6 mm and below are often utilized in peripheral regions of the body and appendages. Today, the most successful in this respect are grafts of PTFE of the material disclosed by Robert W. Gore in

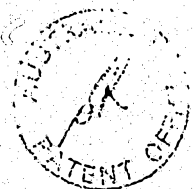

S. Polansky in U.S. Patent No. 3,304,557 avoids crimping in vascular prothesis by forming a tube with repeating reinforcing ring sections. These reinforcing ring sections incorporate reinforcing picks adjacent only the outer surface. He proposes that the annular rings can be in the form of a helix, alternating rings and helix-loops. These latter suggestions are similar to the tubular prothesis of I. B. Medell in U.S. Patent No. 3,479,670 wherein an open mes. tube is wrapped with two polypropylene monofilament right-hand and left-hand helices and fused to penetrate partially the exterior of the tube. In U.S. Patent No. 3,272,204 to C. Artandi and L. D. Bechtol sew a Dacron fabric to Teflon rings or a helix to prevent an absorbable collagen reinforced graft tube from collapsing.

Selection of a particular type of graft substrate by a vascular surgeon depends upon several factors. Among the factors included is the particular location of the implantation. This also dictates the size of the graft in order to maintain a sufficiently large or small lumen to accommodate normal blood flow in the region of implantation. The ultimate strength requirements and blood pressure in the location of implantation also affect the selection. Generally, the woven grafts provide greater strength and reduced porosity, but are generally considered to be more difficult to handle and suture. Velours are often preferred because the velour surfaces facilitate growth of tissue into the loops extending from the surface of the velour fabric. The knitted grafts are generally softer and more easily sutured, but are generally more porous. Depending on the location of the implant and heparinization condition of the patient, synthetic fabric grafts generally must be preclotted with the patients blood before implantation. Preclotting may not be essential with a woven graft, but is generally recommended nonetheless.

Tubular grafts of smaller diameter, for example, 6 mm and below are often utilized in peripheral regions of the body and appendages. Today, the most successful in this respect are grafts of PTFE of the material disclosed by Robert W. Gore in



U.S. Patents Nos. 4,187,390 and No. 3,953,566. These grafts are formed by extrusion of the PTFE material. While accepted for use in small diameter applications, PTFE grafts often require surgical replacement within relatively short periods of time compared to the larger diameter fabric vascular grafts described above.

Accordingly, it is desirable to provide a synthetic fabric vascular graft suitable for a wide variety of dimensions and diameters providing the benefits of woven grafts, but which do not require crimping and will be self supporting and maintain an open lumen.

#### SUMMARY OF THE INVENTION

Generally speaking, in accordance with the invention, self-supporting a woven synthetic vascular grafts having improved kink resistance including a stiffening component in the filling yarn is provided. The stiffening component of the filling yarn provides radial burst strength, dimensional stability and radial rigidity with resiliency to maintain the lumen of the tubular structure open and provide the necessary burst strength properties. The graft may also include low modulus elastomeric warp yarns. In one preferred embodiment, a plurality of elastomeric and multifilament warp yarns are woven in tubular form with a filling yarn of stiffer monofilament and multifilament yarn which have been twisted together. The elastomeric warp yarns provide longitudinal compliance (stretch) which aids in bending flexibility. The graft surfaces may be smooth or as a single or as a double velour.

In a single velour self-supporting vascular graft, the inner surface is provided with a fine, low profile woven surface to promote smooth, thin pseudointima formation. The loops on the exterior surface are formed of multifilament warp yarns which provide the necessary texture cover for tissue adhesion and ingrowth. The multifilament warp yarns and the multifilament component of the filling yarns control blood porosity. The filling yarn is a monofilament yarn twisted with

a multifilament yarn to provide required strength and reduce porosity.

The self-supporting woven grafts prepared in accordance with the invention are particularly well suited to 2-6 mm diameter peripheral vascular prosthesis, but are suitable for larger dimensions up to about 40 mm as well. Kink resistance is provided without the necessity to crimp the vascular graft.

Accordingly, it is an object of the invention to provide an improved woven synthetic vascular graft.

Another object of the invention is to provide a self-supporting woven synthetic vascular graft which resists kinking without the need to crimp the graft.

A further object of the invention is to provide a woven synthetic fabric vascular graft which is suitable for peripheral use in small diameters of 6 mm or less.

Still another object of the invention is to provide a small diameter woven synthetic fabric vascular graft which resists kinking and provides a desirable amount of longitudinal stretch without crimping.

Still a further object of the invention is to provide a self-supporting woven synthetic fabric vascular graft which includes an outer velour surface to promote tissue ingrowth.

Yet another object of the invention is to provide a self-supporting woven synthetic vascular graft having a fine, low profile woven surface to promote smooth, thin pseudointima formation.

Yet a further object of the invention is to provide a self-supporting woven synthetic fabric single-velour vascular graft having improved kink resistance without crimping.

Another object of the invention is to provide a method of preparing an improved self-supporting woven synthetic fabric vascular graft in accordance with the invention.

Still other objects and advantages of the invention will in part be obvious and will in part be apparent from the specification.

The invention accordingly comprises the several steps and the relation of one or more of such steps with respect to each of the others, the apparatus embodying features of construction, combination and arrangement of parts which are adapted to effect such steps, and the product which possesses the characteristics, properties, and relation of constituents (components), all as exemplified in the detailed disclosure hereinafter set forth, and the scope of the invention will be indicated in the claims.

#### BRIEF DESCRIPTION OF THE DRAWINGS

For a fuller understanding of the invention, reference is had to the following description taken in connection with the accompanying drawings, in which:

FIG. 1 is a weaving diagram of a woven synthetic fabric vascular graft prepared in accordance with a preferred embodiment of the invention;

FIG. 2 is a cross-sectional view in schematic in the warp direction of a finished graft section showing the interlacing ends of filling yarn of a graft fabric having the weave pattern of FIG. 1;

FIG. 3 is a perspective view of a tubular woven single-velour vascular graft prepared in accordance with the invention; and

FIG. 4 is a perspective view of a bifurcated woven single-velour vascular graft prepared in accordance with the invention.

#### DESCRIPTION OF THE PREFERRED EMBODIMENTS

The woven tubular synthetic vascular grafts prepared in accordance with the invention are applicable to a wide range of diameters, including the small 2 to 6 mm diameter range suitable for peripheral use as well as dimensions up to about 40 mm. Accordingly, the grafts woven having inside diameters which range from about 2 to about 40 mm and are self-supporting and resist kinking without being crimped.

The stiffening component in the filling yarns may be a textile material, such as a monofilament yarn. Selection

will vary depending on the desired characteristic of the tubular graft. However, the stiffening component must be sufficiently stiff to impart dimensional stability and radial rigidity to the tube without crimping. The stiffening component should have the following minimum physical properties:

Tenacity:	≥ 3 grams per denier 3.726.3 Kg/cm <sup>2</sup> or (53,000 psi)
Initial Modulus:	≥ 50 grams/denier 56,245.5 Kg/cm <sup>2</sup> or (800,000 psi)
EI:	≥ 1.09 x 10 <sup>-4</sup> Kg. cm <sup>2</sup> or (3.9 x 10 <sup>-6</sup> lb in. <sup>2</sup> )

Where EI is the bending stiffness, E is the initial modulus of elasticity and I is the moment of inertia. The diameter can vary depending on desired characteristics, but will typically be in the range of about 0.05 to 0.25 mm (2 to 10 mils).

In one preferred embodiment of the invention, the woven graft has a diameter less than about 6 mm. In another preferred embodiment the woven graft has an exterior surface with loops and a smooth interior surface. The grafts are self-supporting and resistant to kinking without crimping the fabric surface. The grafts possess longitudinal elasticity imparted by including a plurality of thermoplastic low modulus elastomeric yarns as a component of the warp yarns. Elastomeric Yarns have properties which exhibit high stretch, low modulus, and good elastic recovery. Typical properties for yarns suitable for use would be:

Elongation to Break:	>100%
Modulus of Elasticity:	<1 gram per denier
Elastic Recovery:	>80%
or	
Tensile Set:	<20%

The resin can either be thermoplastic or thermoset, but should possess good biocompatibility. The remaining yarns utilized are those which are compatible biologically. Such yarns include polyethylene terephthalate, polyurethane, polytetrafluoroethylene and silicone.



Preferably, the majority of the yarn utilized in the woven graft is polyethylene terephthalate, such as Dacron available from du Pont. The remaining component is the elastomeric yarn which may be present in amounts ranging from about 2 to 20 percent by weight. The graft substrate is formed by weaving a plurality of warp yarns including elastomeric yarn and multifilament yarn with filling yarns of stiffer monofilament yarn and multifilament yarn which have been twisted together prior to weaving. The stiffer monofilament component of the filling yarn provides mechanical strength, dimensional stability and radial rigidity with resiliency which maintains an open lumen for normal blood flow and provides the necessary burst strength. The elastomeric warp yarn component provides longitudinal compliance which aids in bending flexibility.

The monofilament polyester utilized as a stiffening component in the Examples which follow is a 5 mil polyethylene terephthalate yarn. The yarn has the following physical properties:

Diameter:	0.127 mm (.005 inch or 5 mils)
Tenacity:	6.2 grams per denier 7733.8 Kg/cm <sup>2</sup> or (110,000 psi)
Initial Modulus:	112 grams per denier 139,207.7 Kg/cm <sup>2</sup> (1,980,000 psi)

$$I \text{ (moment of inertia)} = \frac{\pi r^4}{64}$$

Calculated Bending Stiffness = E x I

$$EI = 1.07 \times 10^5 \text{ Kg cm}_2 \text{ (} 3.8 \times 10^6 \text{ lb.in.}^2 \text{)}$$

The multifilament warp yarns and multifilament component of the filling yarns provide the necessary texture and cover for tissue adhesion and ingrowth on the outer surface and assist in controlling porosity of the graft. The velour loops are of multifilament warp yarns on the outer surface only. The inner surface has a fine, low profile which promotes smooth, thin pseudointima formation.

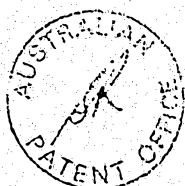

**SUBSTITUTE SHEET**

The particular selection of elastomeric and multifilament warp yarns together with the stiffer combined monofilament and multifilament filling yarns provide a graft having improved kink resistance over a wide range of diameters. Thus, smaller bending radii can be achieved without occluding. In the preferred single velour construction, the external velour surface promotes tissue ingrowth.

FIG. 1 illustrates the weaving pattern of a woven vascular graft substrate 11 prepared in accordance with a preferred embodiment of the invention. Substrate 11 is woven from a plurality of warp ends 12 and filling yarn 13. FIG. 2 is a schematic illustration of substrate 11 in cross-section with a smooth interior surface 14 and a velour exterior surface 16 having loops 17 of multifilament warp yarns 19 which stand away from the surface of the graft.

Referring to FIG. 1, warp yarns 12 include alternating ground warp ends of a first multifilament yarn 18 and, a low modulus elastomeric monofilament yarn 19. In the illustrated embodiment multifilament yarn 18 is a one ply seventy denier untexturized preshrunk (flat) polyethylene terephthalate (Dacron) yarn (1/70/54) with a 52 twist (one ply/70 denier 54 filaments). Elastomeric yarn 19 is a 140 denier polyurethane (Lycra Spandex) or an S-E-B-S (styrene-ethylene-butylene-styrene block copolymer). Two ends of multifilament ground warp yarn 18 alternate with one end of ground warp elastomeric yarn 19. The loop or pile component 17 of warp yarns 12 is a multifilament warp yarn 21 which alternates with each end of warp ground yarns 18 and 19. In substrate 11, multifilament yarn 21 is an texturized unshrunk 2/40/27 (two ply/40 denier, 27 filaments with a 1.5s twist) polyethylene terephthalate (Dacron) yarn.

Filling yarn 13 is a combined yarn of a monofilament yarn component 22 twisted together with a multifilament yarn component 23 to form filling yarn 13. In substrate 11, monofilament yarn 22 is a 0.127 mm (5 mil) polyethylene terephthalate monofilament yarn twisted with multifilament yarn component 23 which is a texturized preshrunk yarn 2/40/27 (1.5s).

SUBSTITUTE SHEET

This is the same yarn as texturized preshrunk warp direction yarn 21. The components are twisted 1.5 turns per 2.54 cm (inch) in the "s" direction.

Elastomeric component 19 of warp yarns 12 may be formed of any one of the biologically compatible materials having a low modulus of elasticity as noted above. The modulus of elasticity is typically less than 1 gram per denier with an elongation to break greater than 100 percent. For example, the elastic component may be a polyester, polyurethane, silicone or other compatible copolymers such as a styrene-ethylene-butylene-styrene block copolymer known as a C-Flex resin available from Concept Polymers. The elastomeric component is present in substrate 11 in an amount between about 2-20 percent by weight. Preferably, elastomeric component 19 is present in an amount about 5 to 10 percent by weight. The styrene-ethylene-butylene-styrene block copolymer monofilament yarn is 0.127 mm (5 mil) C-Flex. An alternative preferred yarn suitable for elastomeric component 19 is a Lycra polyurethane yarn of 140 denier.

FIG. 3 is a perspective view of a tubular graft 31 prepared in accordance with the invention. Graft 31 has a smooth inner surface 32 and external raised fabric velour surface 33 having a multiplicity of outwardly extending loops 34. Similarly, FIG. 4 illustrates a bifurcated graft 41 having a main body segment 42 and two legs 43 and 44. Legs 43 and 44 are joined to main body 42 at a crotch 46 which is generally reinforced by a row of stitches 47 to maintain as tight an initial porosity of the graft as possible. Graft 41 has a smooth interior surface 48 and an external surface 49 having loops 51.

As is evident from the weaving pattern of FIG. 1, loops 34 and 51 of grafts 31 and 41, respectively are formed from multifilament warp pile yarns. In substrate 11 the pile yarns are texturized unshrunk polyester yarns 21.

After weaving substrate 11 in the pattern as shown in FIG. 1, grafts 31 and 41 are scoured and washed in a hot water and detergent bath which results in about 10 to 30 percent longitudinal shrinkage. The washed tubes are cut to desired

SUBSTITUTE SHEET

lengths and heatset in a convection oven on straight aluminum mandrels at about 175°C for about 15 minutes to one hour. The grafts can also be heat set in a non-straight condition to create shaped grafts, such as an aortic arch, which will not have to be bent or shaped by the surgeon during implantation.

As discussed above, and as shown in FIGS. 3 and 4, tubular woven vascular grafts 31 and 41 prepared in accordance with the invention are not crimped in order to maintain an open lumen. This is due to inclusion of the relatively stiffer monofilament component 22 in filling yarns 13 and elastomeric component 19 in warp yarns 12.

The specifications of the yarn utilized and substrate 11 are set forth in the following Examples. These Examples are presented for purposes of illustration and are not intended in a limiting sense.

Example 1

Tubular grafts were woven with the following yarns on the pattern of FIG. 1.

TUBULAR WEAVE CONSTRUCTION:

Ground weave for lattice structure: plain  
Warp float weave for loop or pile surface:  
Crowfoot (floats on outside surfaces, See FIG. 2) alternates every other end (See FIG. 1)

YARN CONSTRUCTION:

Warp Ground: 1/70/54 (5z) Untexturized Preshrunk Dacron 56 Polyester & 5 mil C-Flex, alternating 2 ends of Dacron 56 Polyester and 1 end of C-Flex.  
Warp Float: 2/40/27 Texturized Unshrunk Dacron 56 Polyester (1.5s).  
Filling: 5 mil PET Monofilament wound together with 2/40/27 Preshrunk Texturized Dacron (1.5s).



DENSITY DESCRIPTION:

Sley: 320 ends per 2.54 cm (inch) (40 dents/2.54 cm (inch) x 8 ends/dent)  
 Picks: 60 picks per 2.54 cm (inch) per layer (120 total) inserted.

TUBE DESCRIPTION:

Greige Inside Diameters: 4.5, 5.5 & 6.5 mm  
 Finished Inside Diameters: 4, 5 & 6 mm

Example 2

In another preferred embodiment in accordance with the invention a 140 Denier Lycra Spandex monofilament yarn is utilized as the elastomeric component 19 in the same pattern as substrate 11. Tubular vascular grafts having an identical weaving pattern as shown in FIG. 1 are formed with the following specifications:

TUBULAR WEAVE CONSTRUCTION:

Ground weave for lattice structure: plain  
 Warp float weave for loop or pile surface: crowfoot (floats on outside surface, See FIG. 2) weave alternates on every other end (See FIG. 1)

YARN CONSTRUCTION:

Warp Ground: 1/70/54 (52) untexturized unshrunk Dacron 56 polyester and 140 Denier Lycra monofilament, alternating 2 ends of polyester and 1 end of Lycra.  
 Warp Float: 2/40/27 (1.5s) - Dacron 56 Texturized Preshrunk Polyester.  
 Filling: 5 mil PET Monofilament wound together with 2/40/27 preshrunk textured Dacron 56 polyester.

DENSITY DESCRIPTION

Sley: 320 epi (40 dents/2.54 cm (inch) x 8 ends/dent)  
 Picks: 60 picks per inch inserted per layer in tubular form.

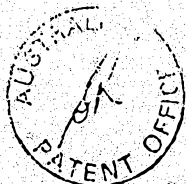

TUBE DESCRIPTION:

Greige Inside Diameter: 8 mm  
 Finished Inside Diameter: 4.8 mm

The velour for both grafts was formed by weaving every other end in a crowfoot pattern, which allows the warp yarn to float over three picks and under one pick. The remaining adjacent ends form a plain weave. Every third warp end in the lattice structure is Lycra or C-Flex, which in total means that one in six warp ends is elastomeric yarn. The elastomeric yarn causes the fabric to retract in length which raises the floats of the warp weaving in a crowfoot pattern to form loops.

After weaving, the self-supporting woven single velour graft material of Example 2 was scoured and dried and then rinsed to remove trace chemicals and dried again. Scouring shrank or relaxed the graft tubing about 20.5%. The relaxation which occurs contributes to the ultimate longitudinal stretch.

The tubing was pressed along the tubing edges to remove the crease line formed during weaving. The tubing was then cut to 36 cm lengths and heatset by sliding them onto straight aluminum mandrels at the cut length and placed into a convection oven at 121°C for 20 minutes.

The Dimensional changes before and after finishing were as follows:

<u>Property</u>	<u>Example 2</u>
Longitudinal Shrinkage from greige to scoured, %	20.5
Longitudinal Shrinkage from scoured to heatset, %	11.3
Total longitudinal shrinkage from greige to heatset, %	29.5
Fabric count after weaving, epcm x ppcm (epi x ppi)	75.6± 0 x 27.8±0 (192±0 X 70.5±2.2)



**SUBSTITUTE SHEET**

Fabric count after scouring, epcm x ppcm (epi x ppi)	75.6±0 x 34.6±0.4 (192±0 X 88.7±1)
Fabric count after heat setting, epcm x ppcm (epi x ppi)	75.6±0 x 39.4±0.4 (192±0 X 100±1)

The porosity of the grafts was measured using a Wesolowski permeability tester. Six specimens were tested at two locations. The paired values were added together and reported as a single value. The grafts were tested both relaxed and stretched using a 4 lb weight. The results were as follows:

Permeability (ml/min/cm<sup>2</sup>)

<u>Graft</u>	<u>Relaxed</u>	<u>Stretched</u>
WSV (Lycra)	1004±96	1284±124

The average burst strength of the graft was determined by measuring six graft samples on an Instron Tensile Tester and was 35.8±4.1 Kg/cm<sub>2</sub> (509±58psi).

A woven single velour graft woven with Lycra Spandex [WSV (Lycra)] was tested for the force required to pull a suture from the end of the graft. One 2-0 Dexon suture was inserted through the graft 3 mm from the edge. The graft was mounted in the bottom pneumatic grip of the Instron Tensile Tester and the suture in the top grip. The tensile tester was activated to cause the suture to be torn from the graft. The graft exhibited a suture pullout of 7.50±.3 kg for a cut edge and 7.66±.21 kg for cauterized specimens.

Observations of the failed specimens disclosed that the cut edge grafts had an elongated hole before the filling yarns ruptured. The cauterized grafts had a more circular hole before rupture. This suggests that cauterizing the graft end is preferable to minimize distortion of the suture hole as well as prevent unravelling of the yarns during handling.

Thickness

The graft wall thickness and pile height was determined using SEM analysis. The average overall wall thickness was 0.80 mm with a pile height of 0.48 mm.

### Longitudinal Compliance

The longitudinal compliance is a relative measurement of the ability of the graft to elongate at a given force and is expressed as the percent elongation per kilogram force. The longitudinal compliance was measured on an Instron Tensile Tester using pneumatic grips as follows.

The Instron was set to the following settings:

Full Scale Load:	2 kg
Crosshead Speed:	25.4 cm/mm (10 in/min)
Chart Speed:	25.4 cm/mm (10 in/min)
Gauge Length:	7.62 cm/mm (3 in)
Load Cycling Limits:	0.1 kg to 1.0 kg

The specimens were mounted in the grips with a preload tension of 0.04 kg. The specimens were cycled between 0.1 and 1.0 kg for a total of 50 cycles. On the 50th cycle, the strip chart recorder was activated to record the event. After the last cycle, the crosshead was returned to the 0.1 kg force and stopped. The extension indicated on the digital readout was recorded. This value was added to the original gauge length of 3 inches to arrive at the effective gauge length for calculating the percent elongation and compliance. The average longitudinal compliance was 23.4 %/kg.

### Kink Resistance

The relative kink resistance was measured in a dry, non-pressurized condition. This was a quick test to see if the graft could be bent longitudinally without kinking. If or when it did kink, to what extent, as determined by the inside radius of curvature.

Four graft specimens, 15 to 20 cm in length, were looped in a circular fashion such that the ends were facing in opposite directions. The ends were slowly and gently pulled so as to reduce the diameter of the loop. The ends were pulled until the first evidence of kinking occurred in the wall of the grafts. This procedure took place on the surface of a metric ruler so that the inside diameter could be continuously monitored to capture the point of kinking.

The WSV (Lycra) grafts kinked at a diameter of  $18 \pm 1.7$  mm. If we divide the diameter by two to obtain the inside radius of curvature and then divide this by the inside graft diameter of 4.8 mm, we obtain a  $1.9 \pm 0.2$  Rad./Graft Diameter value which can be used for comparing to other grafts.

These grafts prepared in accordance with the invention are considered kink resistant, since they are flexible longitudinally and can be looped or bent to a significant degree. Typically, rigid or non-longitudinally compliant grafts or tubular structures will kink immediately upon the application of sufficient stress to deform the structure about their longitudinal axis.

#### Radial Compression

Radial compression of the graft was measured to determine the crush resistance of the graft. Four specimens between 15 and 20 cm in length were individually mounted into an Instron Tensile Tester with a flat plate compression apparatus, which measured 10.16 cm (4 inches) in diameter. The specimens were mounted into the compression apparatus so that the ends of the grafts extended beyond the ends of the plates. The gap between the upper and lower plates was reduced so that they came into contact with the specimens and exerted a preloaded force of .02 kg. The distance between the plates was measured with a Vernier to the nearest 0.5 mm, which is the initial gap. The crosshead travel was started at a rate of 1.27 cm/min (0.5 inches/min) and stopped when the grafts were completely compressed.

The strip charts generated were analyzed by measuring the slope of the curves to determine the compression moduli. The compression modulus is calculated by the following formula:

$$\text{Compression Modulus, g/cm} = \frac{\text{Force, g} \times \text{Initial gap, mm}}{\text{Displacement, mm} \times 4 \text{ in} \times 2.54 \text{ cm/in}}$$

In order to compare the values of two types of grafts with different diameters the modulus values can be normalized by multiplying them by the inside diameters of the graft. The

resulting units are grams - millimeter diameter per centimeter length.

The self-supporting WSV (Lycra) grafts exhibited a radial compression of  $2850 \pm 182$  g-mm/cm. The radial compression is an important property in contributing to the ability of a graft to resist kinking when deformed. If the radial compression is high with respect to longitudinal compliance or stiffness, then kink resistance is achieved. If radial compression is low, the wall of the graft is more flexible and consequently kinks more readily.

Graft substrate 11 in FIG. 1 includes every third ground warp end of elastomeric component 19 resulting in one in six warp ends being elastomeric component 19. Elastomeric component 19 causes substrate 11 to retract in length which raises the floats of the warp yarns to form loops in a crowfoot pattern to form loops 17. Filling yarn 13 includes texturized preshrunk polyester, but may be either texturized or untexturized depending on the shrinkage characteristics desired. The only requirement is that these yarns be multifilament to assist in reducing porosity of the graft and facilitating tissue adhesion and ingrowth after implantation. The stiff monofilament component of filling yarn 13 provides radial burst strength, dimensional stability and radial rigidity with resiliency to maintain an open lumen for normal blood flow and provide the necessary burst strength of the graft.

The characteristics and properties of the graft woven in accordance with the invention can be varied as desired by selection and combination of the starting warp and filling yarns and the weaving pattern. In the illustrated examples, the warp ground yarns are multifilament untexturized unshrunk (or flat) polyester, but could be texturized or untexturized preshrunk or unshrunk, or elastomeric yarns. The preferred loop yarn is a multifilament texturized polyester yarn, but could also be untexturized, preshrunk or unshrunk. The sole limiting feature is that there be sufficient multifilament yarns considering the desired end results. The filling yarn is

a composite monofilament twisted with a multifilament component of texturized preshrunk yarn.

It will thus be seen that the objects set forth above among those made apparent from the preceding description, are efficiently attained and, since certain changes may be made in the above article without departing from the spirit and scope of the invention, it is intended that all matter contained in the above description and shown in the accompanying drawings shall be interpreted as illustrative and not in a limiting sense.

It is also to be understood that the following claims are intended to cover all of the generic and specific features of the invention herein described and all statements of the scope of the invention which, as a matter of language, might be said to fall therebetween.

THE CLAIMS DEFINING THE INVENTION ARE AS FOLLOWS:

1. A self-supporting tubular woven synthetic vascular graft including a filling yarn characterized by:

the filling yarn including a stiffening component to provide radial burst strength, dimensional stability and radial rigidity sufficient to maintain the lumen of the tubular structure open woven together throughout the length of the weave, and wherein said stiffening component is present in each pick of the weave.

2. The woven synthetic vascular graft of claim 1, wherein the stiffening component is a polyethylene terephthalate yarn.

3. The woven synthetic vascular graft of claim 1, wherein said stiffening component is twisted with multifilament yarn.

4. The woven synthetic vascular graft of claim 1, further including a plurality of warp ends including multifilament yarns.

5. The woven synthetic vascular graft of claim 1, further including a plurality of warp ends wherein at least a portion of said warp ends are elastomeric yarns.

6. A self supporting tubular woven synthetic vascular graft characterized by:  
a plurality of warp yarns woven together with at least one filling yarn to provide a fabric; and wherein said

filling yarn comprises a 2-ply yarn, one of said plies including a stiffening component to render said graft self-supporting without crimping.

7. The woven vascular graft of claim 6, wherein the warp yarns include multifilament yarn; and wherein the multifilament yarn is polyethylene terephthalate.





8. The woven vascular graft of claim 6, wherein the stiffening component is a monofilament component of polyethylene terephthalate yarn.
9. The woven vascular graft of claim 6, wherein the filling yarn includes monofilament yarn twisted together with multifilament yarn.
10. The woven vascular graft of claim 9, wherein the multifilament component of the filling yarn is polyethylene terephthalate yarn.
11. The woven vascular graft of claim 10, wherein the multifilament and monofilament components of the filling yarn are polyethylene terephthalate.
12. The woven vascular graft of claim 11, wherein the monofilament component of the filling yarn is polyethylene terephthalate wound together with preshrunk, texturized multifilament polyethylene terephthalate.
13. The woven vascular graft of claim 12, wherein the multifilament yarn of the warp is preshrunk.
14. The woven vascular graft of claim 13, wherein the preshrunk yarn is polyethylene terephthalate.
15. The woven vascular graft of claim 6, including a plurality of warp ends of an elastomeric yarn.
16. The woven vascular graft of claim 15, wherein the elastomeric yarn is a polyurethane.
17. The woven vascular graft of claim 15, wherein the elastomeric yarn is a styrene-ethylene-butylene-styrene block copolymer.
18. The woven vascular graft of claim 6, wherein the warp yarns include



preshrunk texturized and unshrunk untexturized polyethylene terephthalate yarn.

19. The woven vascular graft of claim 6, wherein the warp yarns include preshrunk texturized and unshrunk texturized polyethylene terephthalate yarn.

20. The woven vascular graft of claim 6, wherein the warp ends include a plurality of elastomeric yarns, and the elastomeric yarns alternates with the multifilament yarn.

21. The woven vascular graft of claim 20, wherein two ends of multifilament yarn alternate with one end of elastomeric yarn.

22. The woven vascular graft of claim 6, wherein the graft has at least one velour surface of a plurality of warp pile ends of multifilament yarn.

23. The woven vascular graft of claim 22, wherein the warp pile end alternates between each warp ground ends.

24. The woven vascular graft of claim 23, wherein the vascular graft is a tube with a single outside velour surface and a smooth interior surface, the velour surface formed from warp pile yarns of unshrunk texturized multifilament yarn.

25. The woven vascular graft of claim 24, wherein the warp pile yarn is unshrunk texturized polyethylene terephthalate.

26. The woven vascular graft of claim 1, wherein the filling yarn includes a monofilament having a diameter from about 0.05 to 0.25 mm (2 to 10 mils).

27. A self-supporting tubular single velour <sup>synthetic</sup> woven vascular graft, comprising:  
a plurality of warp ground ends including multifilament yarn;  
a plurality of warp pile ends of multifilament yarn; and

a filling yarn comprising a monofilament yarn wound together with multifilament yarn, and wherein said monofilament yarn has sufficient stiffness to render said graft self-supporting without crimping.

28. The woven vascular graft of claim 27, wherein the filling yarn is monofilament polyethylene terephthalate wound together with preshrunk texturized multifilament polyethylene terephthalate yarns.

29. The woven vascular graft of claim 28, wherein the warp ground ends are alternating preshrunk untexturized multifilament polyethylene terephthalate yarns and elastomeric yarns.

30. The woven vascular graft of claim 29, wherein the vascular graft is a tube with a single outside velour surface and a smooth interior surface, the velour surface formed from warp pile ends of unshrunk texturized multifilament polyethylene terephthalate yarn.

31. The woven vascular graft of claim 6, wherein the ends of the tube have been cauterized.

32. The woven vascular graft of claim 6, wherein the tubular graft is bifurcated having a main body portion and two branches.

33. The woven vascular graft of claim 6, wherein the graft has a circular cross-section and is straight longitudinally.

34. The woven vascular graft of claim 6, wherein the graft has a circular cross-section and is curved along its length.

35. A process of preparing a self-supporting woven <sup>synthetic</sup> vascular graft, comprising:

weaving a tube of a plurality of warp ends including multifilament yarns

with a filling yarn of a stiffening component sufficient to render the graft self-supporting without crimping;  
scouring said woven tube; and  
heat setting the fabric.

36. The process of claim 35, including weaving the tube with warp ends of elastomeric yarn.

37. The process of claim 35, wherein heat setting is carried out by placing the tube on a straight mandrel and heating to set the tube to a round cross-section and longitudinally straight shape.

38. The process of claim 35, where the heat setting is carried out by placing the tube on a curved mandrel, applying heat to set the tube into a the shape of the mandrel.

DATED this 31st day of January, 1995.

MEADOX MEDICALS, INC.

WATERMARK PATENT & TRADEMARK ATTORNEYS  
LEVEL 4, AMORY GARDENS  
2 CAVILL AVENUE  
ASHFIELD N.S.W. 2131  
AUSTRALIA

LJD:RJD:JL VAX doc 012 AU8437991

84 379 | 91

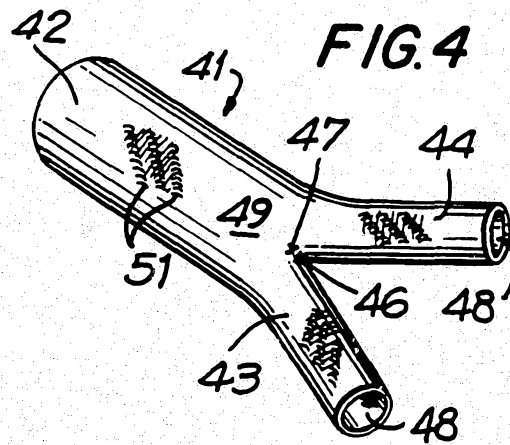
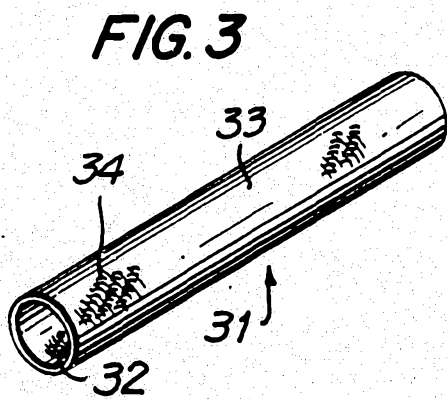
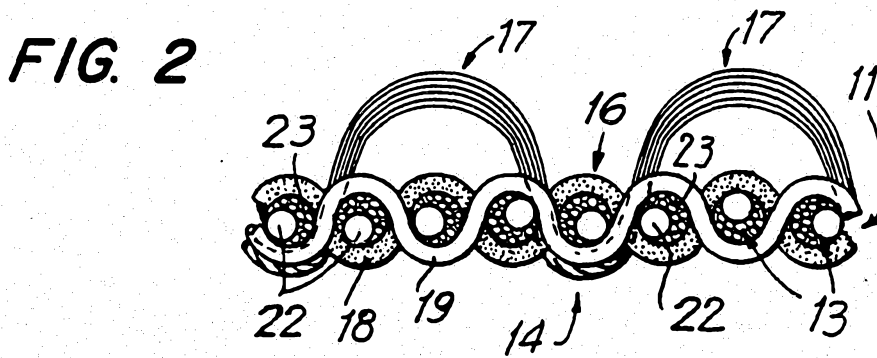
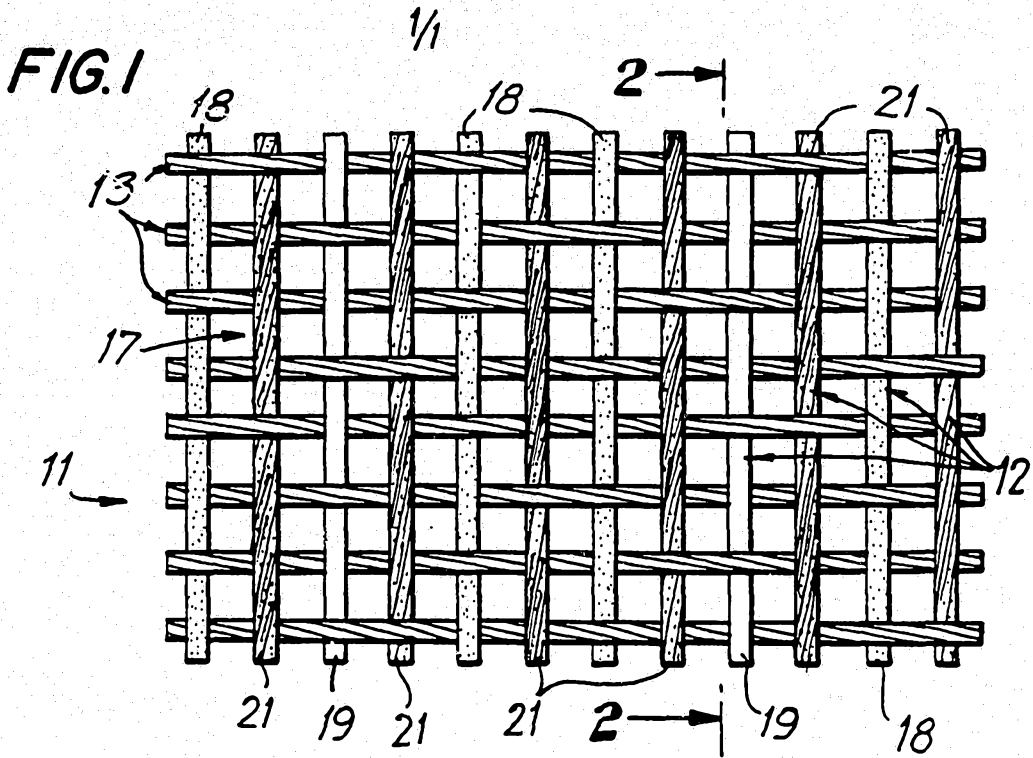

**INTERNATIONAL SEARCH REPORT**

International Application No

PCT/US 91/05907

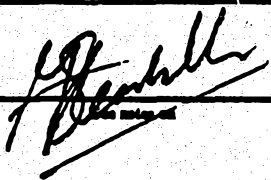
<b>I. CLASSIFICATION OF SUBJECT MATTER</b> (if several classification symbols apply, indicate all) <sup>6</sup>		
According to International Patent Classification (IPC) or to both National Classification and IPC Int.Cl. 5 A61F2/06		
<b>II. FIELDS SEARCHED</b>		
Minimum Documentation Searched <sup>7</sup>		
Classification System	Classification Symbols	
Int.Cl. 5	A61F	
Documentation Searched other than Minimum Documentation to the Extent that such Documents are Included in the Fields Searched <sup>8</sup>		
<b>III. DOCUMENTS CONSIDERED TO BE RELEVANT<sup>9</sup></b>		
Category <sup>9</sup>	Citation of Document, <sup>11</sup> with indication, where appropriate, of the relevant passages <sup>12</sup>	Relevant to Claim No. <sup>13</sup>
X	GB,A,820 014 (DAVENPORT) 16 September 1959  see the whole document ---	1-4,6,8, 34-37, 38,40,41
A	US,A,3 304 557 (POLANSKY) 21 February 1967 cited in the application ---	-
A	EP,A,0 122 744 (HOWMEDICA) 24 October 1984 ---	-
A	WO,A,8 303 752 (WALLSTEN) 10 November 1983 ---	-
A	US,A,4 517 687 (MEADOX MEDICALS) 21 May 1985 cited in the application ---	-
<p><sup>10</sup> Special categories of cited documents :</p> <p>"A" document defining the general state of the art which is not considered to be of particular relevance</p> <p>"E" earlier document but published on or after the international filing date</p> <p>"L" document which may throw doubts on priority claim(s) or which is cited to establish the publication date of another citation or other special reason (as specified)</p> <p>"O" document referring to an oral disclosure, use, exhibition or other means</p> <p>"P" document published prior to the international filing date but later than the priority date claimed</p> <p>"T" later document published after the international filing date or priority date and not in conflict with the application but cited to understand the principle or theory underlying the invention</p> <p>"X" document of particular relevance; the claimed invention cannot be considered novel or cannot be considered to involve an inventive step</p> <p>"Y" document of particular relevance; the claimed invention cannot be considered to involve an inventive step when the document is combined with one or more other such documents, such combination being obvious to a person skilled in the art.</p> <p>"A" document member of the same patent family</p>		
<b>IV. CERTIFICATION</b>		
Date of the Actual Completion of the International Search	Date of Mailing of this International Search Report	
02 JANUARY 1992	17. 01. 92	
International Searching Authority	Signature of Authorized Officer	
EUROPEAN PATENT OFFICE	STEENBAKKER J. 	

**ANNEX TO THE INTERNATIONAL SEARCH REPORT  
ON INTERNATIONAL PATENT APPLICATION NO. US 9105907  
SA 50854**

This annex lists the patent family members relating to the patent documents cited in the above-mentioned international search report. The members are as contained in the European Patent Office EDP file on  
The European Patent Office is in no way liable for these particulars which are merely given for the purpose of information. 02/01/92

Patent document cited in search report	Publication date	Patent family member(s)	Publication date
GB-A-820014		None	
US-A-3304557		None	
EP-A-0122744	24-10-84	US-A- 4610688	09-09-86
		AU-B- 554461	21-08-86
		AU-A- 2636584	11-10-84
		CA-A- 1220601	21-04-87
		JP-C- 1375239	22-04-87
		JP-A- 59194738	05-11-84
		JP-B- 61040420	09-09-86
		US-A- 4834755	30-05-89
WO-A-8303752	10-11-83	SE-B- 445884	28-07-86
		AU-A- 1518683	21-11-83
		CA-A- 1239755	02-08-88
		CH-A- 662051	15-09-87
		DE-T- 3342798	10-01-85
		FR-A- 2525896	04-11-83
		GB-A, B 2135585	05-09-84
		JP-T- 59500652	19-04-84
		NL-T- 8320142	01-08-84
		SE-A- 8202739	31-10-83
		US-A- 4954126	04-09-90
		US-A- 4655771	07-04-87
US-A-4517687	21-05-85	CA-A- 1215896	30-12-86
		DE-A- 3278417	09-06-88
		EP-A, B 0108171	16-05-84
		JP-A- 59049757	22-03-84