



- (51) International Patent Classification:
B01J 2/06 (2006.01) *C05C 9/00* (2006.01)
- (21) International Application Number:
PCT/IB2017/057385
- (22) International Filing Date:
24 November 2017 (24.11.2017)
- (25) Filing Language: Italian
- (26) Publication Language: English
- (30) Priority Data:
102016000119699 25 November 2016 (25.11.2016) IT
- (71) Applicant: EUROTECNICA MELAMINE, LUXEM-
BURG, ZWEIGNIEDERLASSUNG IN ITTIGEN
[CH/CH]; c/o Peter Muntwyler, Fürsprecher und Notar,
Talgut-Zentrum 19, CH-3063 Ittigen (CH).
- (72) Inventor: CAVUOTI, Giacomo; Via Drudi, 29, I-47923
Rimini (IT).
- (74) Agent: DE GREGORI, Antonella et al.; Via Borgogna, 8,
I-20122 Milano (IT).
- (81) Designated States (*unless otherwise indicated, for every
kind of national protection available*): AE, AG, AL, AM,
AO, AT, AU, AZ, BA, BB, BG, BH, BN, BR, BW, BY, BZ,
CA, CH, CL, CN, CO, CR, CU, CZ, DE, DJ, DK, DM, DO,
DZ, EC, EE, EG, ES, FI, GB, GD, GE, GH, GM, GT, HN,
HR, HU, ID, IL, IN, IR, IS, JO, JP, KE, KG, KH, KN, KP,
KR, KW, KZ, LA, LC, LK, LR, LS, LU, LY, MA, MD, ME,
MG, MK, MN, MW, MX, MY, MZ, NA, NG, NI, NO, NZ,
OM, PA, PE, PG, PH, PL, PT, QA, RO, RS, RU, RW, SA,
SC, SD, SE, SG, SK, SL, SM, ST, SV, SY, TH, TJ, TM, TN,
TR, TT, TZ, UA, UG, US, UZ, VC, VN, ZA, ZM, ZW.
- (84) Designated States (*unless otherwise indicated, for every
kind of regional protection available*): ARIPO (BW, GH,
GM, KE, LR, LS, MW, MZ, NA, RW, SD, SL, ST, SZ, TZ,
UG, ZM, ZW), Eurasian (AM, AZ, BY, KG, KZ, RU, TJ,
TM), European (AL, AT, BE, BG, CH, CY, CZ, DE, DK,
EE, ES, FI, FR, GB, GR, HR, HU, IE, IS, IT, LT, LU, LV,
MC, MK, MT, NL, NO, PL, PT, RO, RS, SE, SI, SK, SM,

(54) Title: PLANT AND PROCESS FOR THE PRODUCTION OF SOLID UREA IN GRANULES

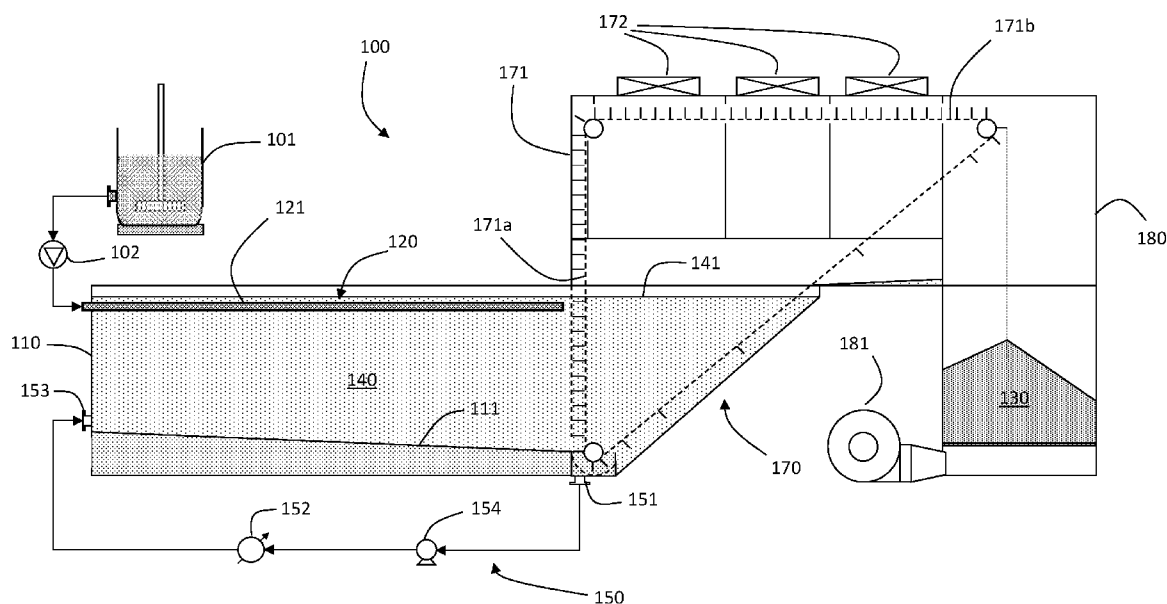

FIG. 2

(57) Abstract: The present invention concerns a plant and a process for the production of solid urea in granules. The plant (10,100,200,300,400,500) for the production of solid urea in granules comprises at least one first tank (11,110,210,310, 410,510) for the formation of granules of urea and a dripping unit (12,120,220,320,420) provided with at least one feeding hole (12a,222,422) for feeding molten urea in the form of drops into the first tank (11,110,210,310,410,510) and is characterized in that the first tank (11,110,210,310,410,510) is filled with at least one cooling liquid (14,140,240,340,440,540) immiscible with molten urea.



TR), OAPI (BF, BJ, CF, CG, CI, CM, GA, GN, GQ, GW,
KM, ML, MR, NE, SN, TD, TG).

Published:

— *with international search report (Art. 21(3))*

PLANT AND PROCESS FOR THE PRODUCTION OF SOLID UREA IN GRANULES

The present invention concerns a plant and a process for the production of solid
5 urea in granules.

In particular the present invention refers to a plant for the production of solid urea
in granules, capable of operating with a lower energy consumption and having
reduced dimensions.

The urea is obtained from a reaction of ammonia and carbon dioxide, from which
10 a salt is obtained which melts at 135°C and which, in solution, has a clear
colourless appearance.

Once produced, the molten urea undergoes a finishing phase in which it is
transformed into a format suitable for subsequent use as an end product, for
example fertilizer, animal feed or another type of end product.

15 This finishing phase generally entails treating the molten urea by means of
appropriate plants for the production of urea granules, generally in the form of
prills.

In the present description and in the following claims, by prill we mean a
substantially spherical ball of solidified urea.

20 A first known urea granule production plant consists of a cylindrical tower,
generally made of reinforced concrete, with typical dimensions up to a height of
50 metres and a diameter of 20 metres, which is called prilling tower.

At the top of the prilling towers a perforated frustoconical distribution basket is
provided which distributes a shower of liquid urea as it rotates.

25 As the urea droplets fall, they pass from the liquid state to the solid state by
cooling, thereby forming the urea prills.

The urea prills thus formed are collected at the bottom of the tower and
transported on a conveyor belt to the storage warehouses.

The Applicant has observed that said plant, in addition to having imposing dimensions, only allows prills with very small diameters to be obtained, generally equal to 1-2.5 mm. In particular for use as fertilizer in agriculture, prills with much larger diameter, for example equal to or greater than 8 mm, also known as
5 megaprills, are highly desirable in order to obtain a gradual release of nitrogen, uniformly distributed over time.

Alternatively to the prilling towers, the finishing phase can be performed by means of a plant for the production of solid urea in granules known as fluidized bed granulator which comprises a tank with air blown in from below at a
10 temperature of approx. 40-60 °C.

Again, liquid urea is sprayed from below which, once solidified into small particles, is kept suspended by the air blown in. Continuing to spray liquid urea from below, the particles swell while they are moved by the air, as the liquid urea adheres to their surface and, solidifying, causes them to increase in diameter.

15 The Applicant has found that said plant, like the prilling towers, has imposing dimensions. Furthermore, in order to obtain prills with large diameters, the solidified particles have to be kept in suspension for a long time. This results in an enormous consumption of energy.

They are also known processes and plants as those disclosed in CA666178 or
20 GB937447, wherein the molten urea is dripped in a bath of a liquid having a boiling temperature at the working pressure (about atmospheric pressure) some tenths of degrees lower than the starting temperature of the molten urea droplets. In said plants of cooling of the prill, the molten urea drops are generated through nozzles or feeding hole of small diameter (about 1 mm) and dropped above the
25 free surface of the cooling bath from a variable height depending on the case from 12 cm to about 2 cm (5-1 inches). By adopting a low-boiling liquid maintained at a temperature well below the starting temperature of the drops, the nozzles must be kept sufficiently distant from the liquid to prevent the early solidification of the melt, but close enough to prevent crushing of the drop in the collision with the

- free surface of the cooling bath. The formation of droplets in the gaseous intersection entails an upper limit to their size determined by the balance between surface tension at the nozzle mouth and drop weight less floating force. The drop, as it is generated in this gaseous layer, has a very small floating force due to the
- 5 low density of the gas, and therefore cannot grow beyond a certain size (4-5 mm as stated in the above cited documents). The cooling of the prills is therefore, in all cases, for the first part of the bath, obtained by evaporation of the bath liquid and formation of a vapor film around the drop that prevents it from contact with the liquid.
- 10 The cooling mechanism for evaporation is the predominant one, taking into account the great difference between the melting temperature of the urea drop (which tends to remain constant even if the cooling occurs by concentric layers of the prill) and the bath temperature (equal to or less than the boiling point of the cooling liquid).
- 15 Further, taking into account the low vaporization heat of the low-boiling hydrocarbons or chlorinated hydrocarbons provided in those documents (50-100 kcal/kg to be compared with 500 kcal/kg of water), large amounts of vapours are produced, which must be re-condensed externally, cooled and pumped back into the prilling tank. A similar system is also described in GB 1535842.
- 20 The Applicant has found that also such systems do not allow the obtaining of prills with large diameters and require the recycling of high amounts of solvents. This results in an enormous consumption of energy.
- Last but not least, with all the known plants described above, substantially spherical urea granules are obtained, since it is not possible to intervene in any
- 25 way on the shape of the end product.
- Depending on the applications, lenticular or toroidal shapes could be interesting, for example due to the different surface-volume ratio offered by these shapes.
- The Applicant has therefore highlighted the need to provide a plant for the production of solid urea in granules which has reduced dimensions and is able to

operate with lower energy consumption than the known plants.

The Applicant has also recognized the need to provide a plant for the production of solid urea in granules, which is able to produce, in addition to the granule shapes and sizes so far obtainable, urea granules with larger dimensions and
5 different shapes.

The problem underlying the present invention is therefore that of producing a plant for the production of solid urea in granules which has compact dimensions and is characterized by reduced energy consumption.

In the context of this problem, one object of the present invention is to conceive a
10 plant for the production of solid urea in granules which is able to obtain urea granules with both diameters larger and smaller than 8 mm.

A further object of the present invention is to conceive a plant for the production of solid urea in granules which further allows granules with controlled dimensions and both a spherical and non-spherical shape to be obtained.

15 According to a first aspect, the invention therefore concerns a plant for the production of solid urea in granules comprising at least one first tank for the formation of urea granules and a dripping unit provided with at least one hole for feeding molten urea in the form of drops into the first tank, characterized in that the first tank is filled with at least one cooling liquid immiscible with molten urea,
20 wherein at least one molten urea feeding hole of the dripping unit is immersed in at least one cooling liquid.

In the present description and in the subsequent claims, the expression "cooling liquid" means a liquid kept at a temperature below the melting temperature of the urea and in particular at a temperature that facilitates the solidification of the
25 molten urea.

In particular, the layer of the at least one cooling liquid in which the at least one molten urea feeding hole of the dripping unit is immersed, is maintained at a temperature comprised between 110 and 125°C, preferably of from 110 to 120°C, namely at a temperature slightly lower than that of solidification of urea which is

equal to 132°C.

This allows the geometric stabilization of the drop after the release from the formation nozzle or feeding hole and before the drop/prill solidification begins.

In fact, the Applicant has observed that by filling the solidification tank with a
5 liquid immiscible with molten urea kept at a temperature below that of the urea melting temperature, it is possible to obtain solidification of the drops of urea, greatly reducing the dimensions of the plant.

Furthermore, the energy necessary to maintain the cooling liquid at a sufficiently low temperature to obtain the solidification of the drops of urea, is a minimum
10 percentage with respect to the consumption of the known plants.

The Applicant has in fact ascertained that, depending on the immiscible liquid used, it is possible to obtain solidification also when the drop travels through the liquid for less than half a metre, i.e. one hundred times shorter than the distance of that required by the prilling towers.

15 Furthermore, the Applicant has found that carrying out the solidification in a cooling liquid offers several further advantages.

For example, by appropriately choosing the density of the cooling liquid it is possible to produce prills with diameters of up to 10 – 14 mm.

In addition, the large floating force due to the high density of liquid surrounding
20 the droplet allows to form even larger drops, up to 15 mm or more, which, by solidifying, can produce the so-called megaprills or megagranules (namely with a size of more than 8-9 mm), used as fertilizer in very important agronomic fields such as rice cultivation.

Performing solidification in a liquid with an appropriate density also allows urea
25 granule shapes to be obtained, different from the spherical shape, for example lenticular or toroidal.

In particular, as cooling liquid, any organic or inorganic compound can be used with a density below the density of the molten urea, in which the urea is insoluble, and the residue of which left on the solidified urea granules, is compatible in

terms of quantity and quality with use of the product.

According to a second aspect, the invention concerns a process for the production of solid urea in granules which is characterized by the fact that it comprises the phases consisting in dripping molten urea into a cooling liquid immiscible with
5 molten urea.

Advantageously, the process for the production of solid urea in granules according to the invention achieves the technical effects described above in relation to the plant for the production of solid urea in granules according to the invention.

The present invention, in at least one of the above-mentioned aspects, can have at
10 least one of the following preferred characteristics; the latter are in particular combinable with one another as required in order to meet the specific application needs.

As above said, at least one molten urea feeding hole of the dripping unit is immersed in at least one cooling liquid.

15 This advantageously prevents freezing of the molten urea drops, which could occur if they are fed into air at ambient temperature.

Immersing the feeding hole in the liquid ensures that the solidification process takes place gradually and uniformly, therefore extending right through up to the centre of the drop.

20 Preferably, at least one cooling liquid has a density below the density of the molten urea, i.e. lower than approximately 1300 kg/m^3 , and the dripping unit is positioned at the free surface of the cooling liquid.

Said configuration advantageously allows the solidification of the urea drops in downflow conditions.

25 In the present description and in the following claims, by the expression "downflow configuration" we mean a configuration in which the urea drops are fed from above and solidify as they fall downwards.

The molten urea feeding hole of the dripping unit is immersed into the cooling liquid and, in the downflow configuration, the liquid layer in which the feeding

hole is dipped is preferably kept at a temperature ranging of from 110 to 120°C.

In fact, the lower density of the cooling liquid with respect to the density of the molten urea determines a descent by gravity once delivered into the liquid.

More preferably, at least one cooling liquid with a density lower than the density

5 of the molten urea is chosen from the group consisting of:

- Edible and vegetable oils;
 - Mineral oils;
 - Light liquid paraffin;
 - Molten waxes;
- 10 – Silicone oils with a density lower than the density of the molten urea.

By way of example, the edible vegetable oils can be seed oils such as sunflower seed, soybean oil, palm oil, castor oil, olive oil, rapeseed oil and so on.

Analogously, mineral oils can be, for example, Vaseline oil.

With reference to molten waxes, they preferably have a melting temperature lower
15 than 80°C.

Said cooling liquids have a boiling temperature far above the maximum temperature of molten drops of urea (132-140°C) and therefore cooling is carried out without evaporation, with liquid-liquid direct contact between the molten urea drop and the bath cooling liquid, with a convective thermal exchange due to the
20 relative drop speed of urea droplet/prill compared to the quiescent oil bath. Cooling is carried out in-situ, with suitably arranged heat exchange surfaces immersed in the tank, without need of extracting an oil stream, cooling it in an external exchanger and pumping it back into the tank. Cooling is then carried out in liquid phase using non-toxic substances (some substances are also used in the
25 food industry) and without the production and condensation of vapors of potentially dangerous, toxic or flammable substances (such as toluene, cyclohexane, chlorobenzene, carbon tetrachloride, hexane).

Advantageously, if vegetable oils or waxes are used as cooling liquid, a coating of the formed granules is automatically obtained which prevents caking, i.e. fusion

between individual granules as a result of heat and humidity.

Preferably, at least one polymer resin is added to at least one cooling liquid.

Advantageously, said resin adheres to the surface of the granule generated, forming a coating, thus making it unnecessary to purposely coat the granules in order to slow down the rapid drainage from rainwater and regulate the release of urea over time, especially in association with the use of megagranules (granules with diameters equal to or greater than 8-9 mm).

Preferably, heavy powders and/or micropowders are added to at least one cooling liquid.

10 By way of example, silica, glass microspheres, metal powders, fossil flour and so on can be used as powders and/or micropowders.

Advantageously, it is thus possible to obtain a liquid with an increased density to increase the diameter of the prill that can be obtained.

Alternatively or additionally, means for generation of a current of at least one cooling liquid from the bottom to the top are provided.

In this way, the characteristic of floating of the drops is increased, prolonging the falling times and thus also obtaining solidification of prills with large dimensions of approximately 10-14 mm.

More preferably, on the bottom of at least one first tank an inclined wall is provided, which extends between a portion positioned at a higher level and a portion positioned at a lower level, a transport unit being arranged at the surface portion at a higher level for conveying urea granules flowing out of at least one first tank.

Alternatively or additionally, a unit for generation of a current of cooling liquid is preferably provided at the bottom of at least one first tank.

More preferably, the unit for generation of a current of cooling liquid is designed to generate a current directed towards the conveying unit.

Advantageously, the inclined wall positioned on the bottom and/or the current of cooling liquid convey the prills deposited on the bottom towards the transport

unit, facilitating the outflow from the tank.

Preferably, the transport unit is partially immersed in at least one first granule formation tank and is preferably made like a perforated conveyer belt with scrapers or perforated bucket elevator or screw elevator.

- 5 More preferably, at least one blower for the evaporation of the cooling liquid is associated with the transport unit.

Preferably, the cold current of cooling liquid which flows on the bottom is kept separate from the cooling fluid above by means of a plurality of flow separating partitions.

- 10 In this manner it is advantageously possible to separate the bottom part of the tank from the upper part, so that the current created on the bottom does not interfere with the drops still not completely solidified during the descent.

Preferably, in at least one first tank, a plurality of cooling plates is arranged.

- In this way it is possible to control the temperature of the liquid present in the upper part of the tank, maintaining it at the ideal temperature for a gradual
15 solidification of the drops.

- Preferably, at least one first tank is filled in addition with a second cooling liquid immiscible with molten urea and having a density higher than the density of the molten urea, a connection opening being provided at the bottom of at least one
20 first tank to a second tank, the second tank being filled with the second cooling liquid.

In this way, the prills generated in downflow remain suspended at the interface between the two liquids with different densities and are driven into the second chamber where they surface and can be easily collected.

- 25 Preferably, at least one cooling liquid has a density higher than the density of the molten urea and the dripping unit is positioned at the bottom of at least one first tank.

Said configuration advantageously allows the solidification of the urea drops in upflow conditions.

In the present description and in the following claims, the expression "configuration in upflow" indicates a configuration in which the urea drops are fed from below and solidify during their ascent towards the top.

In fact, the higher density of the cooling liquid with respect to the density of the molten urea determines an ascent of the latter towards the free surface of the liquid with a higher density, once delivered into said liquid.

More preferably, at least one cooling liquid with higher density than the density of the molten urea is chosen from the group consisting of:

- Molten sulphur;
- 10 - Oils with the addition of heavy powders;
- Perchloroethylene;
- Perfluoropolyethers, also known by the trade name Fomblin[®];
- Silicone oils with a density higher than the density of the molten urea.

Preferably, at the free surface of at least one cooling liquid, a transport unit is provided designed to move the urea granules that have risen to the surface from at least one first tank or, alternatively or additionally, means for the generation of a surface laminar flow of a cooling liquid.

Preferably, the dripping unit in an upflow configuration is provided with means for the generation of a central pressure impulse.

Advantageously, via the generation of a central pressure impulse during delivery of the drop, the urea delivered takes on a toroidal bubble shape and, solidifying, generates correspondingly shaped granules.

Preferably, at least one cooling liquid has a density higher than the density of the molten urea and the dripping unit is positioned at, preferably above, the free surface of the cooling liquid, means for generation of a surface laminar flow of the cooling liquid being provided.

Advantageously, said configuration allows granules to be obtained with lenticular shape since the urea drops delivered from the dripping unit tend to remain on the surface while they solidify, losing their classic spherical bubble shape.

Preferably, the dripping unit comprises at least one manifold or at least one dripping tube provided with a plurality of feeding holes for feeding molten urea in the form of drops into the first tank.

Preferably, centrally to at least one feeding hole for feeding molten urea in the
5 form of drops, a central needle is provided arranged for insertion of an additive in each urea drop during formation of the drop.

Advantageously, it is thus possible to create granules that contain an additive, for example an anti-urease substance, zinc, sulphur or other nutrients which are released once the urea granule has been consumed.

10 Further characteristics and advantages of the present invention will become clearer from the following detailed description of some preferred embodiments thereof, with reference to the accompanying drawings.

The different characteristics in the individual configurations can be combined with one another as required according to the preceding description, to attain the
15 advantages specifically resulting from a particular combination.

In said drawings,

- figure 1 is a schematic representation in lateral elevation of a first preferred embodiment of a plant for the production of solid urea in granules according to the present invention in the downflow configuration;
- 20 - figure 2 is a schematic representation in lateral elevation of a second preferred embodiment of a plant for the production of solid urea in granules according to the present invention in the downflow configuration;
- figure 3 is a schematic representation of a variation of the plant of figure 2;
- figure 4 is a schematic representation in lateral elevation of a third preferred
25 embodiment of a plant for the production of solid urea in granules according to the present invention in the downflow configuration;
- figure 5 is a schematic representation in lateral elevation of a fourth preferred embodiment of a plant for the production of solid urea in granules according to the present invention in the downflow configuration;

- 12 -

- figure 6 is a schematic representation in lateral elevation of a fifth preferred embodiment of a plant for the production of solid urea in granules according to the present invention in the upflow configuration;
- figure 7 is a schematic representation in lateral elevation of a sixth preferred embodiment of a plant for the production of solid urea in granules according to the present invention in the mixed configuration;
- figure 8 is a schematic representation in section of a megaprill obtainable with the plants of figures 1 to 7.

In the following description, for illustration of the figures, identical reference numbers are used to indicate construction elements with the same function. Furthermore, for clarity of illustration, some numerical references may not be repeated in all the figures.

With reference to figure 1, a first embodiment of a plant for the production of solid urea in granules is shown, indicated overall by the number 10.

The plant 10 according to the first embodiment comprises a first tank 11 filled with a cooling liquid 14, immiscible with urea, and a dripper 12 from which drops 13 of molten urea are fed into the liquid through at least one feeding hole 12a.

The feeding hole 12a of the dripper 12 is immersed in the cooling liquid 14 to avoid freezing of the drops of molten urea 13, if they are theoretically fed into air at ambient temperature.

The cooling liquid 14 is preferably chosen from the fluids suitable for the food chain, in order not to alter the properties of the potentially edible urea granules. Examples of suitable fluids are vegetable and edible oils, such as seed oil, soybean oil, olive oil, palm oil, and so on, mineral oils such as, for example, Vaseline oil and silicone oils.

Different prill diameters can be obtained depending on the density of the cooling liquid 14 into which the drops of molten urea 13 are fed and the diameter of the feeding hole 12a of the dripper 12.

For this purpose, heavy micropowders are preferably added to the cooling liquid

14 to increase the density thereof and thus obtain larger prill diameters.

In particular, in the embodiment illustrated in figure 1, a cooling liquid 14 is used having a density lower than the density of the molten urea so as to obtain the configuration in downflow.

- 5 In order to maintain the cooling liquid at a temperature suitable for solidification of the urea, for example at a temperature ranging between 40-80°C, a cooling system for cooling said cooling liquid 14 is provided.

In the embodiment of figure 1, the cooling system comprises a second tank 15 containing a cooling fluid 16, for example cold water, in which the first tank 11 is
10 immersed.

With reference to figure 2, a second embodiment of a plant for the production of solid urea in granules is shown, indicated overall by 100.

The plant 100 according to the second embodiment comprises a tank 110 filled with a cooling liquid 140, immiscible with urea, and a dripping unit 120
15 comprising at least a dripping manifold 121 immersed in the cooling liquid 140 at the free surface 141 of said liquid.

A reservoir 101 of molten urea is connected via a pump 102 to the dripping unit 120 to feed the latter with molten urea.

The manifold 121 of the dripping unit 120 is provided with a plurality of holes
20 (not illustrated) for feeding molten urea in the form of drops into the cooling liquid 140.

The cooling liquid 140 has a density lower than the density of the molten urea so as to obtain the downflow configuration.

The drops of molten urea delivered from the dripping unit 120 solidify as they fall
25 downwards.

On the bottom of the tank 110 filled with cooling liquid 140, an inclined wall 111 is provided on which, the prills 130, formed from solidification of the drops, are deposited, rolling by gravity and entrainment due to a current of cold fluid towards a transport unit 170, said current being purposely generated on the bottom

of the tank.

The transport unit 170 comprises a perforated conveyor belt with scrapers 171, partially immersed in the tank 110 and in the cooling liquid 140, which defines a conveying path for the prills 130, from the tank 110 to a collection tank 180.

- 5 In the embodiment illustrated in figure 2, the conveyor scraper 171 comprises a first vertical branch 171a which transports the prills 130 outside the tank 110, and a second horizontal branch 171b along which the residual liquid left around the prills 130 is drained from the holes provided on the belt. At said second horizontal branch 171b, a plurality of hot air blowers 172 are also arranged for a more rapid
- 10 evaporation and downward entrainment of the residual liquid and consequent drying of the prills 130.

At the end of the horizontal branch 171b, the prills 130 drop by gravity into the collection tank 180.

- Also the collection reservoir 180 comprises a blower 181 which completes the
- 15 drying of the prills 130 collected.

- Lastly, a cooling system 150 is provided, illustrated in figure 2 only schematically, which, in general terms, comprises a withdrawing duct 151 for drawing the cooling liquid 140 from the tank 110, a cooling unit 152 outside the tank 110, a circulation pump 154 and a duct 153 for re-introduction of the liquid 140 into the
- 20 tank 110.

The re-introduction duct 153 is arranged at the height of the inclined wall 111 in order to generate a cold current at the tank inlet which facilitates the movement of the prills towards the transport unit 170.

- Alternatively to the inclined wall 111 and the transport unit 170 provided in the
- 25 plant 100 of figure 2, a transport unit 170' of the type illustrated in figure 3 can be provided.

Said transport unit 170' comprises a plurality of scrapers 171' which, by scraping the bottom of the tank 110', convey the prills deposited there towards an inclined outlet wall 112' of the tank 110'.

With reference to figure 4, a third embodiment of a plant for the production of solid urea in granules is shown, indicated overall by 200.

The plant 200 according to the third embodiment comprises a tank 210 filled with a cooling liquid 240, immiscible with urea, and a dripping unit 220 comprising a
5 plurality of dripping ducts 221, in the figure only the head duct is shown, immersed in the cooling liquid 240 at the free surface 241 of said liquid.

The molten urea is fed in a controlled manner to the dripping unit 220 via a feeding unit 201 (not illustrated in detail).

Each duct 221 of the dripping unit 220 is provided with a plurality of feeding
10 holes 222 for feeding molten urea in the form of drops into the cooling liquid 240.

The cooling liquid 240 has a density lower than the density of the molten urea so as to obtain the downflow configuration.

The drops of molten urea delivered from the dripping unit 220 solidify as they fall downwards, forming prills 230.

15 On the bottom of the tank 210 filled with cooling liquid 240 an inclined wall 211 is provided on which, the prills 230 formed from solidification of the drops deposit, rolling by gravity and entrainment due to a current of cold fluid towards a transport unit 270, said current being purposely generated on the bottom of the tank.

20 The transport unit 270 comprises a bucket elevator 271, partially immersed in the tank 210 and in the cooling liquid 240 which defines a conveying path for the prills, from the tank 210 to a belt conveyor 280 which transports the prills towards a collection tank (not illustrated).

In the embodiment illustrated in figure 4, the bucket elevator 271 comprises a first
25 vertical branch 271a which transports the prills outside the tank 210, and a second horizontal branch 271b, at the end of which the prills drop by gravity onto the belt conveyor 280.

At the top of the first vertical branch 271a a first blower 273 is provided for a first drying of the prills as they are vertically transported.

Furthermore also along the second horizontal branch 271b a plurality of second blowers 272 are arranged which continue drying of the prills as they are transported horizontally.

The buckets 271 of the elevator are perforated in order to allow dripping during
5 the transport and are associated with a vibration unit (not illustrated) which accelerates the dripping phase.

Also below the belt conveyor 280 a blower 281 is provided which continues drying of the prills collected before reaching the tank.

Lastly, a cooling system 250 is provided illustrated in figure 4 only schematically,
10 which, in general terms, comprises a withdrawal duct 251 for drawing the cooling liquid 240 from the tank 210, a liquid cooling unit 252 outside the tank 210 and a re-introduction duct 253 for re-introducing the cooled liquid 240 into the tank 210.

The re-introduction duct 253 is arranged at the height of the inclined wall 211 in
15 order to generate a cold current at the tank inlet which facilitates the movement of the prills 230 towards the transport unit 270.

In order to maintain a separation between the cold current that flows on the bottom of the tank 210 and the cooling fluid 240 above, a plurality of flow separating partitions 212 are provided inside the tank 210.

20 In this way it is possible to maintain a temperature difference between the bottom part and the upper part of the tank 210.

The cooling unit 250 illustrated in figure 4 further comprises a plurality of cooling plates 256 arranged inside the tank 210, above the flow separating partitions 212, and immersed in the cooling liquid 240 which control the temperature of the
25 liquid 240 present in the upper part of the tank 210.

With reference to figure 5, a fourth embodiment of a plant for the production of solid urea in granules is shown, indicated overall by 300.

The plant 300 according to the fourth embodiment comprises a tank 310 filled with a cooling liquid 340, immiscible with urea, and a dripping unit 320

positioned below the free surface 341 of said liquid. The cooling liquid 340 has a density lower than the density of the molten urea so as to obtain the downflow configuration.

On the bottom of the tank 310 filled with cooling liquid 340 a first conical wall
5 311 is provided converging towards a lower level positioned centrally to the tank 310.

The prills 330 formed from the solidification of the drops roll by gravity towards said lower level, reaching a transport unit 370 positioned centrally to the tank 310. The transport unit 370 has the form of a vertical screw lift and is partially
10 immersed in the cooling liquid 340.

At the top of the transport unit 370 a second conical wall 375 is provided which, from the outlet 371 of the transport unit 370 positioned centrally, develops radially towards a lower level, facilitating rolling of the prills 330 towards the periphery of said surface 375.

15 At said periphery, an outlet 374 is provided for collection of the prills 330.

With reference to figure 6, a fifth embodiment of a plant for the production of solid urea in granules is shown, indicated overall by 400.

The plant 400 according to the fifth embodiment comprises a tank 410 filled with a cooling liquid 440, immiscible with urea, and a dripping unit 420 comprising a
20 plurality of dripping ducts 421, in the figure only the head duct is illustrated, immersed in the cooling liquid 440 at the bottom of the tank 410.

The molten urea is fed in a controlled manner to the dripping unit 420 through a feeding unit 401 (not illustrated in detail).

Each duct 421 of the dripping unit 420 is provided with a plurality of feeding
25 holes 422 for feeding molten urea in the form of drops into the cooling liquid 440. The cooling liquid 440 has a density higher than the density of the molten urea so as to obtain the upflow configuration.

The drops of molten urea delivered from the dripping unit 420 solidify as they ascend towards the free surface 441 of the cooling liquid 440, forming prills 430.

At the free surface 441 of the liquid, a transport unit 470 is provided in the form of a conveyor belt with scrapers 471, the scrapers scraping away from the free surface 441 of the liquid, the prills 430 that have surfaced and pushes them towards a lateral side opening 472 through which the prills 430 drop into a
5 collecting tank 480.

Alternatively to the conveyor belt with scrapers 471, the prills 430 can be conveyed towards the outlet via a cold laminar flow of cooling liquid 440 which flows over the surface.

In the embodiment illustrated in figure 6, a cooling system 450 is provided only
10 schematically shown which, in general terms, comprises a plurality of extraction elements 453 for extracting the vapours of the cooling liquid, a condenser 452 outside the tank 410 and a duct 451 for re-introducing into the tank 410 condensed cooling liquid vapours 440, therefore in liquid phase.

With reference to figure 7, a sixth embodiment of a plant for the production of
15 solid urea in granules is shown, indicated overall by 500.

The plant 500 according to the sixth embodiment comprises a first tank 510 filled partly with a first cooling liquid 540, immiscible with urea, having a density lower than the density of the molten urea, and partly filled with a second cooling liquid 545, immiscible with urea, having a density higher than the density of the molten
20 urea.

The two cooling liquids are arranged in layers, with the liquid having a lower density 540 positioned in the upper part.

The first tank 510 is connected in the lower part to a second tank 550 via a connection opening 515 positioned on the bottom of both the tanks. The second
25 tank 550 is filled only with the second cooling liquid 545.

A system 560 for generation of a current of the second cooling liquid 545 is also provided comprising a withdrawal duct 561 for drawing the second cooling liquid 545 from the second tank 550, a pump 562 and a duct 563 for re-introduction into the first tank 510. Both the ducts 563,561 are positioned at the same level, at the

bottom of the respective tank 510,550.

A dripping unit is also provided (not illustrated) immersed in the first cooling liquid 540 at the free surface 541 of said liquid 540.

The drops of molten urea delivered from the dripping unit solidify as they drop
5 downwards, forming prills 530 which remain suspended at the boundary interface between the two phases consisting of the two cooling liquids 540,545.

Furthermore, the current generated by the respective system 560 drags the prills 530 in suspension into the second tank 550 where, due to the density lower than the second cooling liquid 545, they come to the surface.

10 According to a further embodiment (not illustrated), a tank filled with a cooling liquid, immiscible with urea, and a dripping unit positioned at the free surface of the cooling liquid can be provided.

The cooling liquid used has a density higher than the density of the molten urea so as to obtain the upflow configuration and is made to flow on the surface as a
15 laminar flow of cold liquid.

In this way, the drops of urea delivered from the dripping unit tend to remain on the surface, taking on a lenticular shape, and solidify due to the cold laminar flow of liquid.

From the description, the characteristics of the plant for the production of solid
20 urea in granules and the relative process for the production of solid urea in granules subject of the present invention are clear, and likewise the relative advantages.

From the embodiments described above, further variations are possible, without departing from the teaching of the invention.

25 For example, a central needle can be provided arranged at each urea feeding hole of the dripping unit for the insertion, in each drop of urea, of an additive in the drop formation phase.

In this way a prill 20 of the type illustrated in figure 8 is created in which, within the sphere of solid urea 22, a centrally positioned additive 21 is present. The

surface of the sphere 22 is further coated in a protective film 23 created by the drying of the cooling fluid used in the production process.

Furthermore, the dripping unit used in the plant according to the embodiment of figure 6 can be provided with means for the generation of a central pressure
5 impulse, around which the urea delivered is distributed, generating a toroidal drop.

Lastly, it is clear that a plant for the production of solid urea in granules and a process for the production of solid urea in granules conceived as above are subject to numerous modifications and variations, all falling within the invention;
10 furthermore, all the details can be replaced by technically equivalent elements. In practice both the materials used and the dimensions can be modified according to technical requirements.

CLAIMS

1. A plant (10,100,200,300,400,500) for the production of solid urea in granules comprising at least one first tank (11,110,210,310,410,510) for the formation of urea granules and a dripping unit (12,120,220,320,420) provided
5 with at least one feeding hole (12a,222,422) for feeding molten urea in the form of drops into the first tank (11,110,210,310,410,510), characterized in that the first tank (11,110,210,310,410,510) is filled with at least one cooling liquid (14,140,240,340, 440,540) immiscible with molten urea, wherein at least one molten urea feeding hole (12a,222,422) of the dripping unit (12,120,220,320,420)
10 is immersed in at least one cooling liquid (14,140, 240,340,440,540).
2. The plant (10,100,200,300,500) for the production of solid urea in granules according to claim 1, wherein at least one cooling liquid (14,140,240, 340,540) has a density lower than the density of the molten urea and the dripping unit (12,120,220,320,420) is positioned at the free surface (141,241,341) of the
15 cooling liquid (14,140,240,340,440,540).
3. The plant (10,100,200,300,500) for the production of solid urea in granules according to claim 1 or 2, wherein the layer of the at least one cooling liquid in which the at least one molten urea feeding hole (12a,222,422) of the dripping unit (12,120,220,320,420) is immersed, is maintained at a temperature comprised
20 between 110 and 125°C, preferably of from 110 to 120°C.
4. The plant (100,200,300) for the production of solid urea in granules according to claim 2, wherein on the bottom of at least one first tank (110,210,310) an inclined wall (111,211,311) is provided which extends between a portion positioned at a higher level and a portion positioned at a lower level, a
25 transport unit (170,270,370) being arranged at the portion of surface positioned at a lower level for conveying urea granules flowing out of at least one first tank (111,211,311).
5. The plant (500) for the production of solid urea in granules according to any one of the claims 1 to 3, wherein at least one first tank (510) is additionally

filled with a second cooling liquid (545) immiscible with molten urea and having a density higher than the density of the molten urea, a connection opening (515) for connection to a second tank (550) being provided at the bottom of at least one first tank (510), the second tank (550) being filled with the second cooling liquid
5 (545).

6. The plant (100,200,500) for the production of solid urea in granules according to any one of the claims 2 to 5, wherein a generation unit (150,250,560) for generating a current of cooling liquid (140,240,545) is provided at the bottom of at least one first tank (110,210) and/or a generation unit for generating a current
10 of cooling liquid (140,240,340,540) from the bottom to the top of at least one first tank (110,210,310,510).

7. The plant (200) for the production of solid urea in granules according to claim 6, wherein the cold current of cooling liquid (240) that flows on the bottom is maintained separate from the cooling fluid above (240) by means of a plurality
15 of flow separating partitions (212).

8. The plant (200) for the production of solid urea in granules according to any one of the preceding claims, wherein in at least one first tank (210) a plurality of cooling plates (256) are arranged.

9. The plant (400) for the production of solid urea in granules according to
20 claim 1, wherein at least one cooling liquid (440) has a density higher than the density of the molten urea and the dripping unit (420) is positioned at the bottom of at least one first tank (410).

10. The plant (400) for the production of solid urea in granules according to
25 claim 9, wherein at the free surface (441) of at least one cooling liquid (440) a transport unit (470) is provided designed to move granules of urea that have risen to the surface from at least one first tank (441) or, alternatively or additionally, generation means for generating a surface laminar flow of cooling liquid (440).

11. A process for the production of solid urea in granules characterized in that it comprises the step consisting of dripping molten urea into a cooling liquid

- (14,140,240,340,440,540) immiscible with molten urea.
12. The process for the production of solid urea in granules according to claim 11, wherein the cooling liquid (14,140,240,340,540) has a density lower than the density of the molten urea and the dripping phase takes place from the top to the bottom.
13. The process for the production of solid urea in granules according to claim 12, wherein the cooling liquid (14,140,240,340,540) is chosen from the group consisting of:
- Edible and vegetable oils;
 - Mineral oils;
 - Light liquid paraffins;
 - Molten waxes;
 - Silicone oils with a density lower than the density of the molten urea,
 - heavy powders and/or heavy micropowders and/or at least one polymer resin being preferably added to the cooling liquid (14,140,240,340,540).
14. The process for the production of solid urea in granules according to any one of the claims 11 to 13, comprising the step of generating a current of at least one cooling liquid (14,140,240,340,540) from the bottom to the top.
15. The process for the production of solid urea in granules according to claim 11, wherein the cooling liquid (440) has a density higher than the density of the molten urea and the dripping step takes place the bottom to the top.
16. The process for the production of solid urea in granules according to claim 15, wherein the cooling liquid (440) is chosen from the group consisting of:
- Molten sulphur;
 - Perchloroethylene;
 - Perfluoropolyethers;
 - Silicone oils with a density higher than the density of the molten urea heavy powders and/or heavy micropowders and/or at least one polymer resin being preferably added to the cooling liquid (440).

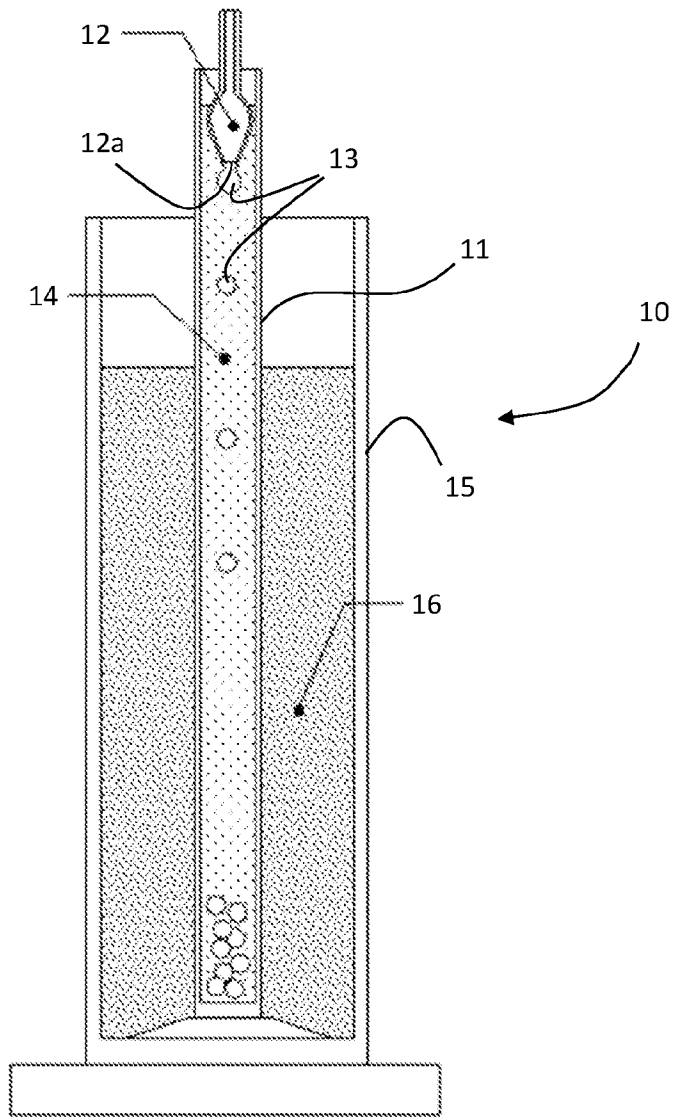

FIG. 1

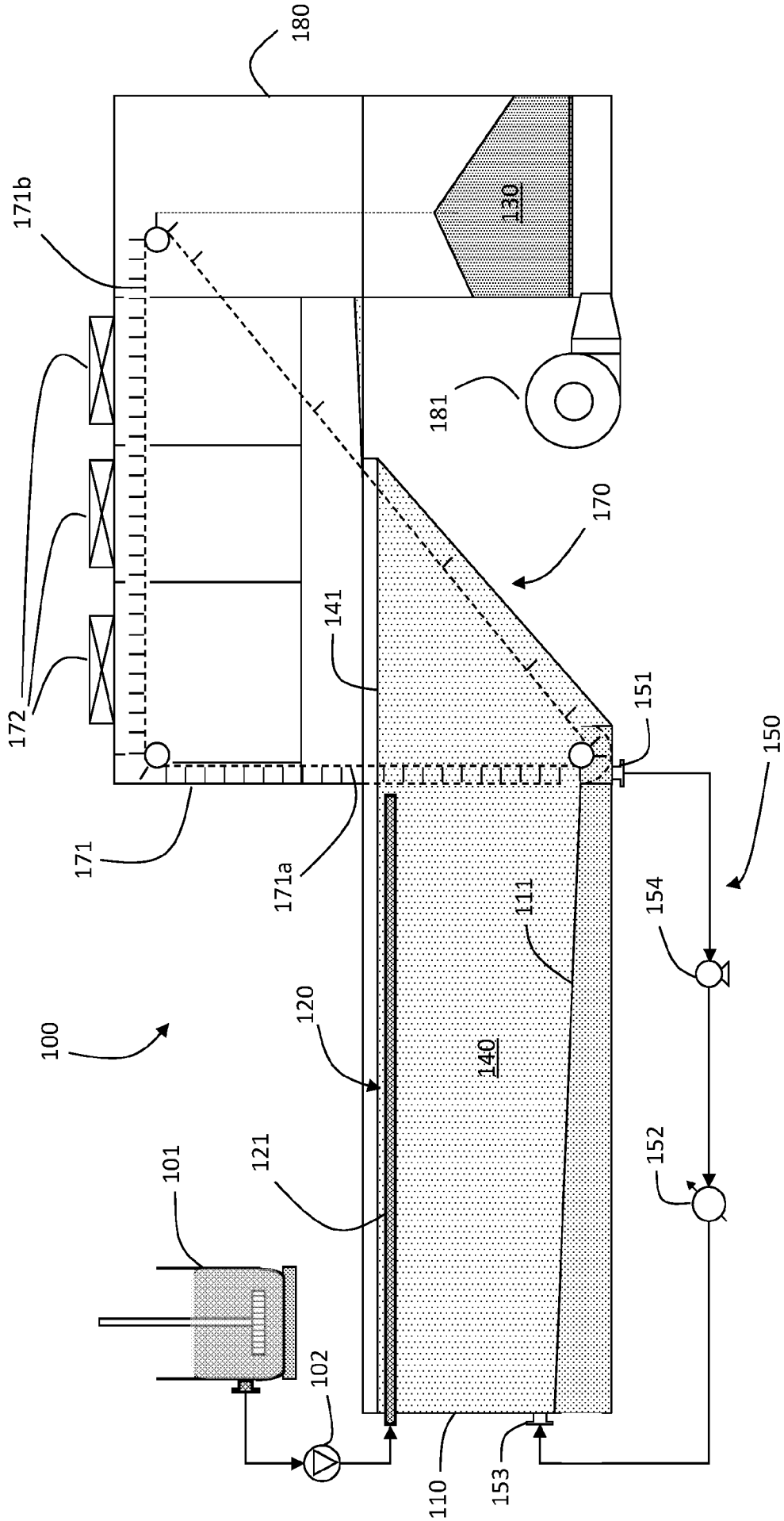

FIG. 2

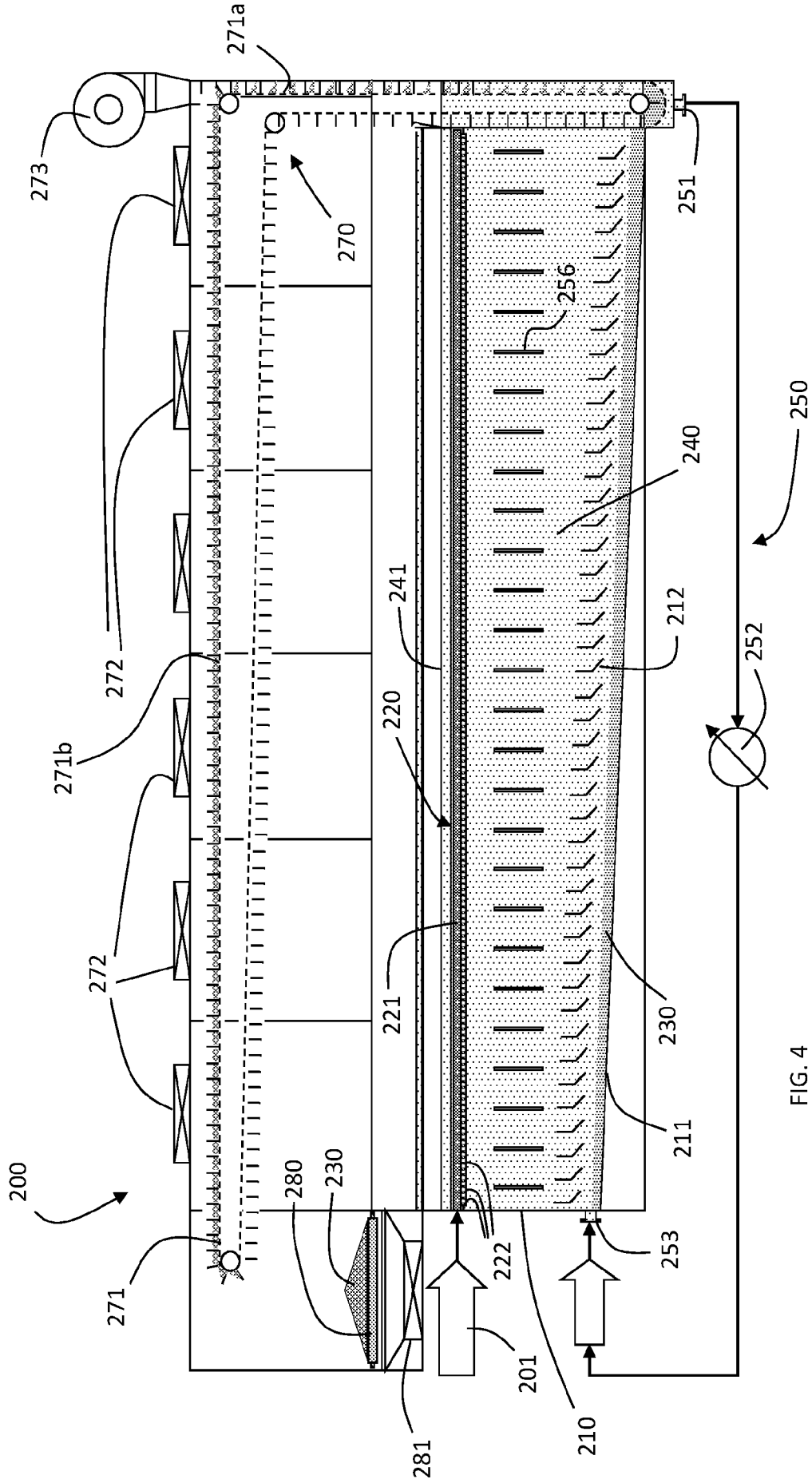

FIG. 4

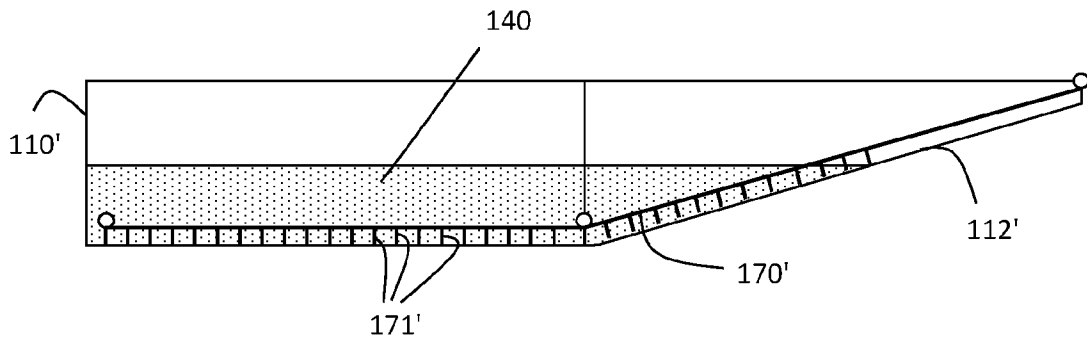

FIG. 3

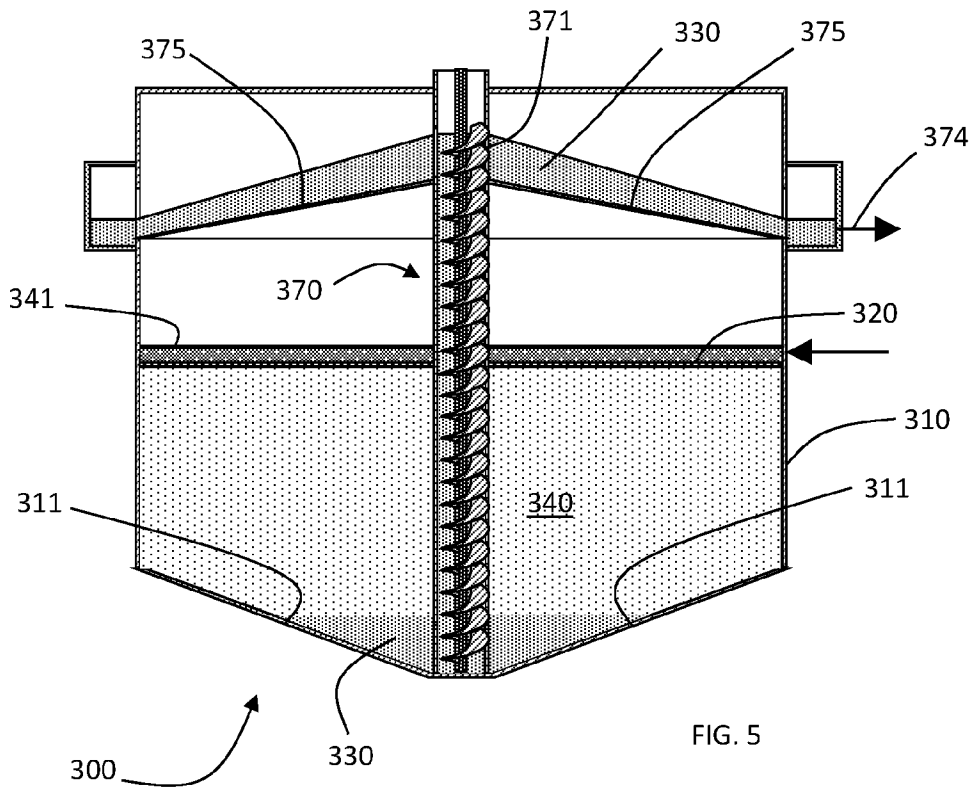

FIG. 5

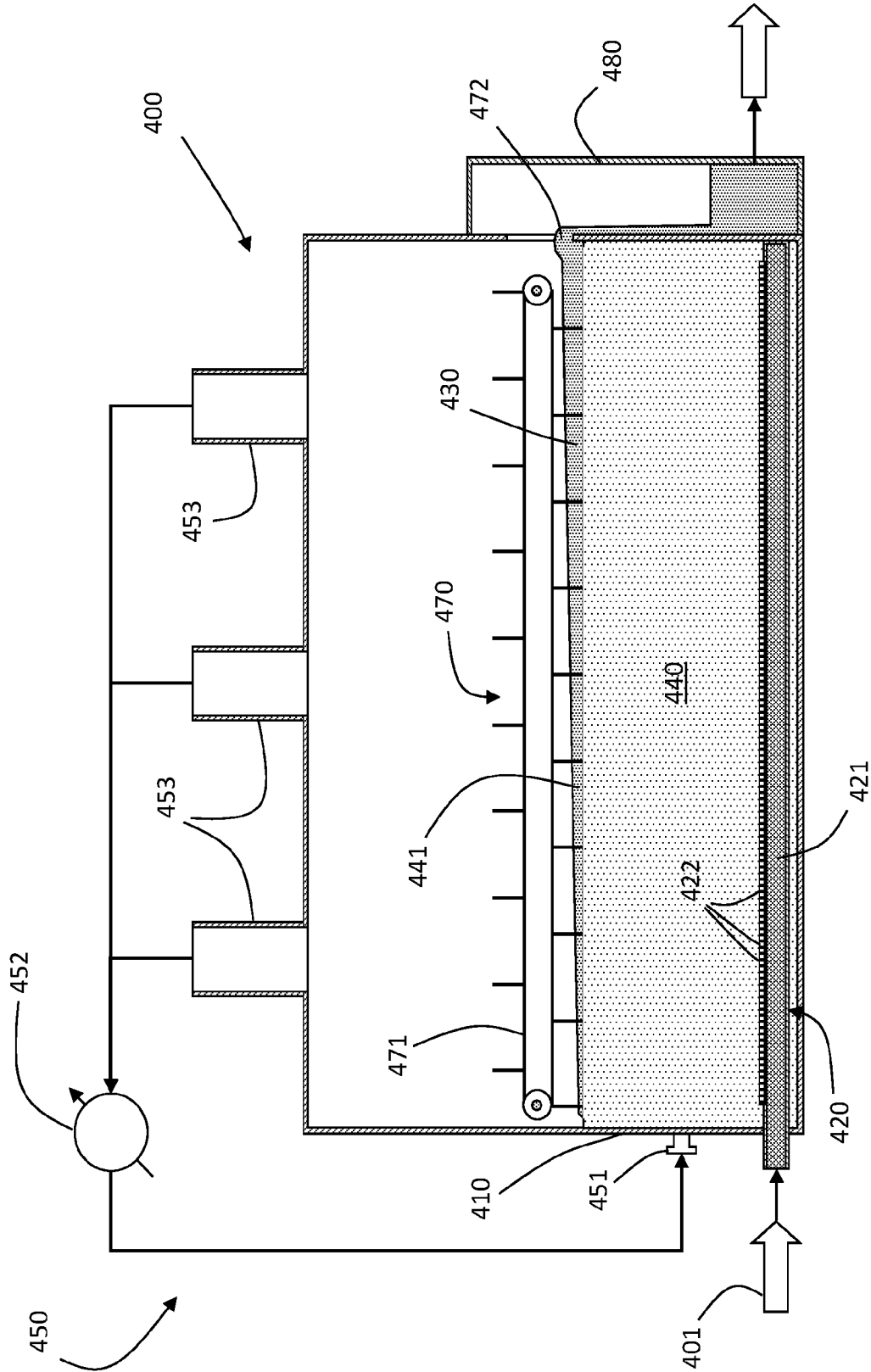

FIG. 6

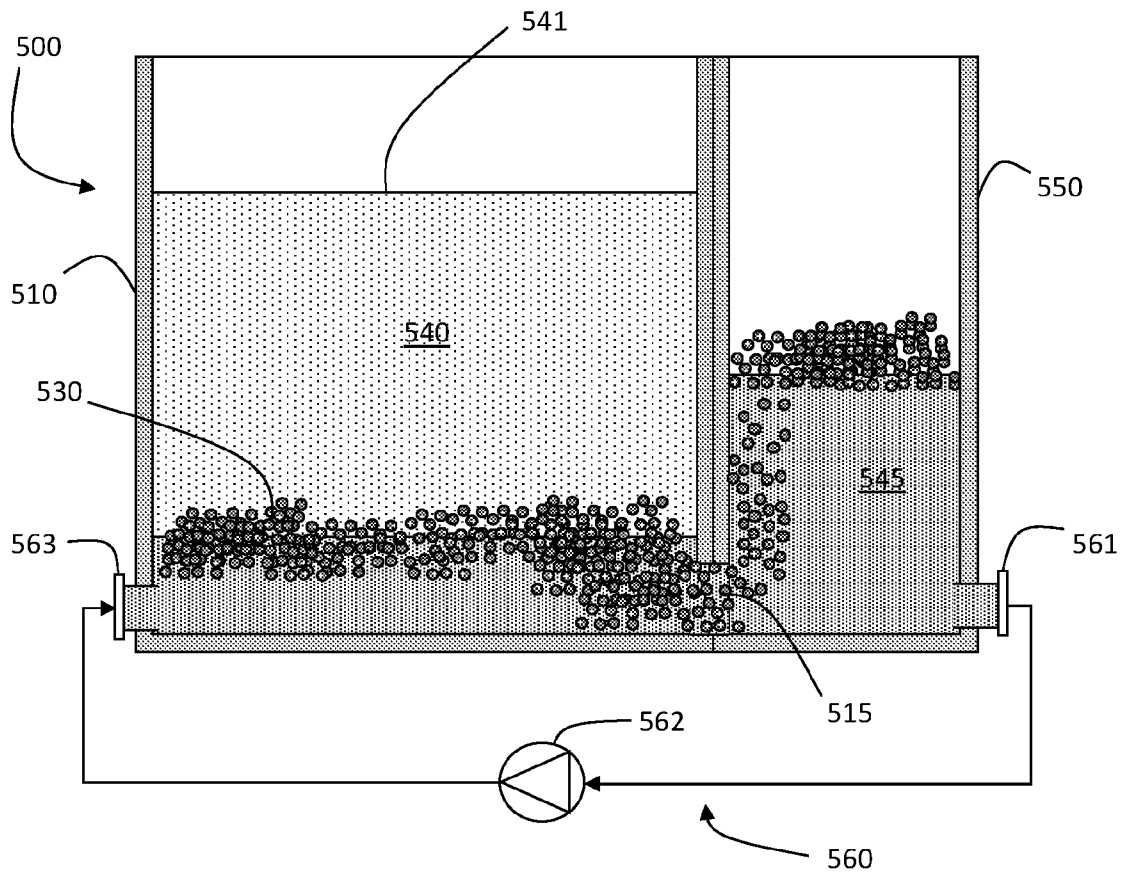

FIG. 7

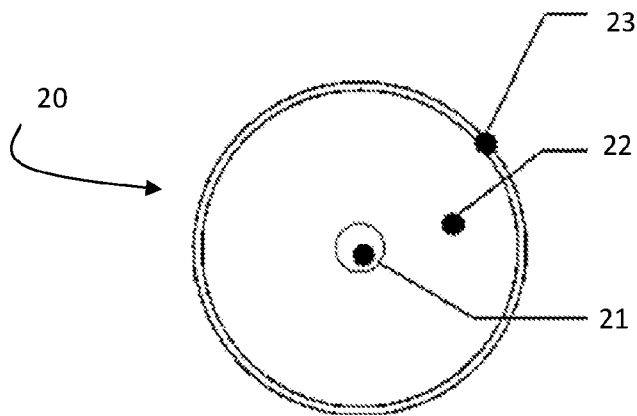

FIG. 8

INTERNATIONAL SEARCH REPORT

International application No
PCT/IB2017/057385

A. CLASSIFICATION OF SUBJECT MATTER
 INV. B01J2/06 C05C9/00
 ADD.
 According to International Patent Classification (IPC) or to both national classification and IPC

B. FIELDS SEARCHED
 Minimum documentation searched (classification system followed by classification symbols)
 B01J C05C
 Documentation searched other than minimum documentation to the extent that such documents are included in the fields searched

Electronic data base consulted during the international search (name of data base and, where practicable, search terms used)
 EPO-Internal, WPI Data

C. DOCUMENTS CONSIDERED TO BE RELEVANT

Category*	Citation of document, with indication, where appropriate, of the relevant passages	Relevant to claim No.
X A	CA 666 178 A (ICI AUSTRALIA LTD) 2 July 1963 (1963-07-02) claims 1-4,12; examples 1-22 -----	11-16 1-10
X A	GB 937 447 A (ICI AUSTRALIA LTD) 18 September 1963 (1963-09-18) claims 1,11; examples 1-22 -----	11-16 1-10
X A	GB 1 535 842 A (USS ENG & CONSULT) 13 December 1978 (1978-12-13) claim 1; figures 1,2 -----	11-16 1-10

Further documents are listed in the continuation of Box C. See patent family annex.

* Special categories of cited documents :

<p>"A" document defining the general state of the art which is not considered to be of particular relevance</p> <p>"E" earlier application or patent but published on or after the international filing date</p> <p>"L" document which may throw doubts on priority claim(s) or which is cited to establish the publication date of another citation or other special reason (as specified)</p> <p>"O" document referring to an oral disclosure, use, exhibition or other means</p> <p>"P" document published prior to the international filing date but later than the priority date claimed</p>	<p>"T" later document published after the international filing date or priority date and not in conflict with the application but cited to understand the principle or theory underlying the invention</p> <p>"X" document of particular relevance; the claimed invention cannot be considered novel or cannot be considered to involve an inventive step when the document is taken alone</p> <p>"Y" document of particular relevance; the claimed invention cannot be considered to involve an inventive step when the document is combined with one or more other such documents, such combination being obvious to a person skilled in the art</p> <p>"&" document member of the same patent family</p>
---	---

Date of the actual completion of the international search 19 January 2018	Date of mailing of the international search report 09/02/2018
Name and mailing address of the ISA/ European Patent Office, P.B. 5818 Patentlaan 2 NL - 2280 HV Rijswijk Tel. (+31-70) 340-2040, Fax: (+31-70) 340-3016	Authorized officer Gilliquet, J

INTERNATIONAL SEARCH REPORT

Information on patent family members

International application No

PCT/IB2017/057385

Patent document cited in search report	Publication date	Patent family member(s)	Publication date
CA 666178	A	02-07-1963	NONE

GB 937447	A	18-09-1963	NONE

GB 1535842	A	13-12-1978	NONE
