



(11) **EP 2 243 453 B1**

(12) **EUROPEAN PATENT SPECIFICATION**

(45) Date of publication and mention of the grant of the patent:  
**21.12.2011 Bulletin 2011/51**

(51) Int Cl.:  
**A61G 5/10 (2006.01)**

(21) Application number: **09158289.0**

(22) Date of filing: **20.04.2009**

(54) **Work chair**

Arbeitsstuhl

Chaise de travail

(84) Designated Contracting States:  
**AT BE BG CH CY CZ DE DK EE ES FI FR GB GR HR HU IE IS IT LI LT LU LV MC MK MT NL NO PL PT RO SE SI SK TR**

(43) Date of publication of application:  
**27.10.2010 Bulletin 2010/43**

(73) Proprietor: **Mercado Medic AB**  
**181 22 Lidingö (SE)**

(72) Inventors:  
• **Ohlsson, Leif**  
**181 22, Lidingö (SE)**

• **Teske, Andreas**  
**181 22, Lidingö (SE)**

(74) Representative: **Strandin, Heléne et al**  
**Bergenstrahle & Lindvall AB**  
**P.O. Box 17704**  
**118 93 Stockholm (SE)**

(56) References cited:  
**EP-A- 1 917 946**      **JP-A- 4 158 864**  
**US-A- 5 209 322**      **US-A1- 2003 189 310**  
**US-A1- 2006 157 953**      **US-A1- 2007 216 131**

**EP 2 243 453 B1**

Note: Within nine months of the publication of the mention of the grant of the European patent in the European Patent Bulletin, any person may give notice to the European Patent Office of opposition to that patent, in accordance with the Implementing Regulations. Notice of opposition shall not be deemed to have been filed until the opposition fee has been paid. (Art. 99(1) European Patent Convention).

**Description**TECHNICAL FIELD

**[0001]** The invention relates generally to work chairs for disabled persons.

BACKGROUND

**[0002]** Wheel chairs known in the art are adapted to enable a physically disabled person to travel considerable distances at relatively high speeds. For this purpose, wheelchairs are designed to place the person in an optimal position for operating the drive wheels with the arms. Furthermore, to get the required balance to travel at relatively high speeds, the center of gravity of the person should be placed close to the rotational axis of the drive wheels, which gives the wheelchair a design which places the person in a low seating, relative to office and dining tables. The wheel chairs of the art furthermore have a relatively large footprint for providing the desired stability of the wheelchair. In an office or dining setting this create problems, which usually requires special adaptations of a room in which a disabled person should work.

**[0003]** Office chairs of the art typically have a wheeled base with a relatively small footprint, preferably not extending to far outside of the radius of the seat. The construction enables the person sitting in the office chair to travel short distances in an office without being confined by the furniture of the room. An office chair of the art could furthermore comprise a telescopic gas cylinder allowing a person to adjust the height of the chair to suit the office table. Another aspect of the height adjustment is that it enables the person to alternate between different seating height, which alleviates the back, neck and legs of strains arising from uniform seating. The wheeled base of an office chair preferably comprises swiveling casters which are rotatable around a vertical axis, an addition to the wheels of the casters rolling in the direction of travel. The caster wheel base allows the office chair to be movable in all directions and thus create an optimal desired position of the chair in relation to the office furniture or desired operating position. Office chairs generally have a stiff base part to which the wheels are attached. The fixed base part construction limits the chairs ability to overcome obstacles such as thresholds and uneven ground surfaces.

**[0004]** In US patent application 2007/0216131, Potappel discloses a wheelchair provided with swiveling casters for use in an office environment. The wheelchair of Potappel has two forward support wheels, preferably casters, which are fixedly attached to a base member, to which the drive wheels of the wheel chair are attached as well. Furthermore the wheelchair comprises two rearward support wheels, preferably casters, which are pivotally mounted to the base part for enabling the person using the chair to travel over obstacles. The pivotally

mounted rearward support wheel allows the wheelchair to rock in a length axis of the wheelchair, the same distance as the rearward support wheel is pivotal. Hence, this construction does not provide the stable behavior desired in an office chair. Potappel further discloses that the drive wheels of the wheelchair can be provided with breaks, which requires the drive wheels to be of a material providing high friction against the ground surface for providing adequate breaking power, this limits the ability to adapt the material of the wheels to the material of the ground surface.

SUMMARY

**[0005]** A work chair as claimed in claim 1 is provided. The work chair comprises at least one rearward support wheel, at least one forward support wheel, at least two drive wheels and a height adjustable seat. The work chair further comprises a bogie base member. One of the at least two drive wheels are rotatably fixated to the bogie base member at a first fixation point, one of: a rearward support wheel and a forward support wheel are rotatably fixated to the bogie base member, at a second fixation point, and the bogie base member is adapted to have a pivot axis substantially between the first fixation point and the second fixation point. The pivot axis enables the wheels of the work chair to stay in contact with the ground surface, even when traveling over uneven surfaces.

**[0006]** According to one embodiment the work chair further comprises a brake member adapted to engage the ground surface for providing a stable position for the work chair. The brake member could comprise a material different from the materials of the at least one rearward support wheel, the at least one forward support wheel, and/or the at least two drive wheels for having a brake member with a higher friction against the ground surface than the friction created between the wheels and the ground surface. The brake member could be adapted to be operable, e.g. using a force selected from a list consisting of: mechanical force, hydraulic force and pneumatic force.

**[0007]** The work chair according to any of the embodiments above could comprise a height adjustable seat, which could be an electrically height adjustable seat enabling a disabled person to adjust the height of the seat to adapt the work chair to its surroundings.

**[0008]** For enabling the work chair according to any one of the embodiments to move in multiple directions, the at least one rearward support wheel, and the at least one forward support wheel could be a swiveling castor.

**[0009]** The work chair according to any of the embodiments could further comprise a lifting device adapted to lift the drive wheels to a point at which the drive wheels do not engage the ground surface. This enables the work chair to be moved in a sideways direction. The lifting device could be a manual lifting device, such as a manual mechanical lifting device, according to one embodiment the lifting device is an electrically powered lifting device,

which could be selected from a group consisting of: pneumatic lifting devices, hydraulic lifting devices and mechanical lifting devices.

**[0010]** For manually propelling the drive wheels, the diameter of the drive wheels could be larger than the diameter of the support wheels, according to one embodiment the diameter of the drive wheels is at least two times as large as the diameter of the support wheels, and according to another embodiment the diameter of the drive wheels is at least four times as large as the diameter of the support wheels.

#### BRIEF DESCRIPTION OF THE DRAWINGS

**[0011]** The invention is now described, by way of example, with reference to the accompanying drawings, in which:

Fig. 1 shows the work chair in a side view, according to a first embodiment.

Fig. 2 shows the work chair in a side view, according to the first embodiment, when traveling over an uneven surface.

Fig. 3 shows the work chair, according to the first embodiment, from above.

Fig. 4 shows the work chair in a side view, according to a second embodiment.

Fig. 5 shows the work chair, according to the second embodiment, from above.

#### DETAILED DESCRIPTION

**[0012]** A bogie is to be understood as a chassis or framework adapted to carry wheels and having a pivot axis.

**[0013]** A bogie base member is to be understood as a part of the bogie construction to which the wheels are directly or indirectly mounted.

**[0014]** A rearward support wheel is to be understood as a wheel having its axis of rotation behind the axis of rotation of the drive wheels, in the normal direction of operation of a chair having drive wheels.

**[0015]** A forward support wheel is to be understood as a wheel having its axis of rotation in front of the axis of rotation of the drive wheels, in the normal direction of operation of a chair having drive wheels.

**[0016]** A drive wheel is to be understood as a wheel which at least at times engages the ground surface with the purpose of propelling the device to which the drive wheel is attached.

**[0017]** In the following a detailed description of preferred embodiments of the present invention will be given. In the drawing figures, like reference numerals designate identical or corresponding elements throughout

the several figures. It will be appreciated that these figures are for illustration only and are not in any way restricting the scope of the invention. Thus, any references to direction, such as "up" or "down", are only referring to the directions shown in the figures. Also, any dimensions etc. shown in the figures are for illustration purposes.

**[0018]** Fig. 1 shows a work chair according to an embodiment in which the work chair comprises two rearward support wheels 3a,b, two forward support wheels 2a,b and two drive wheels 1a,b. The two drive wheels 1a,b are rotatably fixated to a bogie base member 6a,b at a first fixation point 7a,b and are adapted for manual propulsion through the user engaging the manual propulsion bars 8 fixated to the drive wheels 1a,b along the circumference thereof.

**[0019]** The two rearward support wheels 3a,b are rotatably fixated to the bogie base members 6a,b at a second fixation point 12a,b and are, according to the embodiment of fig.1, rearward support wheels 3a,b of the swiveling castor type. The bogie base member 6a is pivotally mounted at a pivot axis 16 located between the first fixation point 7a,b and the second fixation point 12a,b. The first fixation point 7a,b is thus located in front of the pivot axis 16 fixating the bogie base member 6a,b to the work chair and the second fixation point 12a,b is located in behind the pivot axis 16.

**[0020]** The forward support wheels 2a,b are rotatably fixated to forward support bars 5a,b which are parts of a forward support assembly 19 fixedly attached to a base part of the work chair. According to this embodiment, the forward support wheels 2a,b are of the swiveling castor type. The forward 2a,b and rearward 3a,b support wheels being of the swiveling castor type enables the support wheels to rotate around a castor axis 4 extending in a vertical up-down direction, down being in the direction of the ground surface and up being the opposite direction. The rotation around this castor axis 16 enables the work chair to rotate on the area of its footprint, thus rotating around a point placed in the middle of the two drive wheels 1a,b. The support wheels 2a,b, 3a,b being of the swiveling castor type also enables the user to freely move around the work chair, for example by tripping the work chair with the legs, e.g. when the users hand are occupied, or by moving the work chair by pushing or pulling objects of the room using the arms.

**[0021]** The forward 2a,b and rearward 3a,b support wheels are preferably positioned to provide sufficient support to create a stable work chair for the user without the chair getting a far too large over-all footprint limiting the user from moving around in an office or dining setting.

**[0022]** The work chair according to the embodiment shown in fig. 1 further comprises a height adjustable seat 9 comprising a back rest 10. The height adjustable seat 9 is height adjustable by means of a height adjustment cylinder 11 fixated to the base part of the work chair. The height adjustment cylinder 11 could be operable using mechanical force, hydraulic force and pneumatic force. According to the embodiment shown in fig. 1 the height

adjustment cylinder 11 is a gas filled cylinder, as is known from most office chairs of the art, which is controllably connected to a control assembly 20 through a connection line 15. The control assembly is positioned in connection to the seat 9 such that the control assembly 20 is easily accessible to the user. According to other embodiments (not shown) the height adjustment cylinder 11 is electrically powered, which enables less mobile users to operate the height adjustment function without having to deliver a large force, e.g. by operating an electrical switch. Adjusting the height of the work chair could be advantageous as the optimal position for traveling in the work chair using manual propulsion of the drive wheels are much lower than the optimal position in an office or dining setting. When traveling in the chair it could be advantageous to have a center of gravity close to the fixation points 7a,b of the drive wheels 1a,b, since this puts the user in a balanced position in the work chair. The height adjustment of the seat 9 further enables the user to easily adapt to tables of different height, which further reduces the need for adaptation of additional furniture. According to one embodiment the height adjustable seat is rotatable in accordance with most office chairs of the art.

**[0023]** The work chair of fig. 1 further comprises a brake member 13 adapted to engage the ground surface. The brake member 13 can be operable using mechanical force, hydraulic force or pneumatic force, in the embodiment shown in fig. 1 the brake member 13 comprises a pneumatic cylinder operably connected to the same control assembly 20 as the height adjustment cylinder 11. However it is equally conceivable that the pneumatic cylinder operating the brake is controlled from a separate control assembly (not shown). In fig. 1 the brake member 13 is shown in the state in which the brake member 13 engages the ground floor and thus breaks the work chair in relation to the ground surface. The drive wheels 1a,b and the support wheels 2a,b, 3a,b, could have a ground surface contacting layer which is adapted to the material of the ground surface, such as a harder surface contacting layer for softer ground surface materials and a softer surface contacting layer for harder ground surface materials. The adaptation in materials could lead to that the friction, between the ground surface and the wheels, is too low for using the wheels as breaks. The ground surface contacting part 14 of the brake member 13 could therefore comprise a material different from the material of the wheels for creating suitable friction between the contacting part 14 and the ground surface. However in other embodiments (shown in figs. 4 and 5) the brakes engages the wheels, particularly the drive wheels, whereby the drive wheels 1a,b acts as brake members contacting the ground surface.

**[0024]** To enable the manual propulsion of the drive wheels 1a,b in a comfortable way, the drive wheels 1a, b should be made with a larger diameter than the support wheels 2a,b 3a,b. According to one embodiment the diameter of the drive wheels 1a,b is at least two times as large as the diameter of the support wheels 2a,b; 3a,b

and according to another embodiment the diameter of the drive wheels 1a,b is at least four times as large as the diameter of the support wheels 2a,b; 3a,b.

**[0025]** Fig. 2 shows the work chair according to the embodiment of fig.1 when the work chair travels over a threshold 17 by manual propulsion of the drive wheels 1a,b rotatably fixated to the bogie base members 6a,b, which in turn is pivotally mounted to the work chair. When the threshold 17 raises the rearward support wheels 3a, b the bogie base members 6a,b pivots around the pivot axis 16 keeping the drive wheel 1a in contact with the ground surface at all times and thus enables the user to further propel the work chair for continued advancement.

**[0026]** The brake member 13 is here shown in the state in which the brake member 13 does not engage the ground surface and thus do not hinder the work chair from moving.

**[0027]** According to another embodiment (not shown) at least one forward support wheel 2a,b and the drive wheels 1a,b are rotatably fixated to a pivotally mounted bogie base member 6a,b, whereas at least one rearward support wheel 3a,b is fixedly attached to the work chair. This embodiment also fulfills the main purpose of maintaining the contact between the ground surface and wheels, even when traveling over uneven surfaces. It is also conceivable that both the front and rear support wheels are rotatably fixated to a pivotally mounted bogie base member.

**[0028]** Fig. 3 shows the work chair from above showing the rearward support wheels 3a,b being rotatably fixated to the castor axis 4 enabling the support wheels 2a,b; 3a,b to rotate around the castor axis 4 extending in a vertical up-down direction. The castor axis 4 in turn being fixated to the rear part of the bogie base member 6a,b in a second point 12a,b. The brake members 13 are also fixated to the rear part of the bogie base member 6a,b. The drive wheels 1a,b are rotatably fixated to a first point 7a,b of the forward part of the bogie base member 6a,b. The bogie base member 6a,b being pivotally mounted at a pivot axis 16 which extends through a bearing housing 21 which contains the bearings making the pivot axis 16 operable. According to the embodiment shown, the right 6a and left 6b bogie base members are mounted to the same pivot axis 16 interconnecting the movements of the two bogie base members 6a,b. However, according to other embodiments the right 6a and left 6b bogie base members could be connected to a right and left pivot axis and thus individually operable. It could be advantageous for the forward part of the bogie base member 6a,b comprising the drive wheels 1a,b to extend a shorter distance from the pivot axis 16 in a length axis L of the work chair than the rearward part of the bogie base members 6a,b comprising the rearward support wheels 3a,b, since the elevation of the support wheels 3a,b then does not elevate the base part of the work chair as much, and thus the user.

**[0029]** Fig. 3 further shows the forward support assembly 19 fixedly attached to a base part of the work chair.

The forward support assembly 19 comprises the two forward support wheels 2a,b rotatably fixated to the castor axis 4 enabling the support wheels to rotate around the castor axis 4 extending in a vertical up-down direction. The base part of the work chair further comprises the height adjustable cylinder 11 to which the seat 9 and backrest 10 is height adjustably fixated.

**[0030]** Fig. 4 shows the work chair according to another embodiment, in which the work chair further comprises a lifting device in form of an operable cylinder 18 for raising the drive wheels 1a,b above the ground surface through said operable cylinder 18 extending. The raising of the drive wheels 1a,b enables the user to, by means of the support wheels being swiveling casters, e.g. move the work chair sideways which allows the user to better adjust the work chair in an office or dining setting. The operable cylinder 18 can be operable manually mechanical, manually pneumatic/hydraulic or electrically powered mechanically/pneumatic or hydraulic. According to the embodiment shown, the operable cylinder 18 is connected to the control assembly 20, however it is equally conceivable that the operable cylinder 18 is connected to its own control assembly. According to one embodiment (not shown) the raisable drive wheels can be locked in a raised position by means of a locking member.

**[0031]** The brake member 23 as shown in fig. 4 is adapted to engage the drive wheels 1a,b by means of an engaging member 24 operably mounted to the brake member 23. According to the embodiment shown, the brake member 23 is connected to the control assembly 20, however it is equally conceivable that the brake member 23 is connected to its own control assembly.

**[0032]** Fig. 5 shows the work chair from above showing the rearward support wheels 3a,b being rotatably fixated to the castor axis 4 enabling the support wheels 3a,b to rotate around the castor axis 4 extending in a up-down direction. The castor axis 4 in turn being fixated to the rear part of the bogie base member 6a,b in a second point 12a,b. The brake members 23 are also fixated to the rear part of the boogie base member 6a,b. The drive wheels 1a,b is rotatably fixated to a first point 7a,b of the forward part of the bogie base member 6a,b. The bogie base member 6a,b being pivotally fixated at a pivot axis 16 which extends through a bearing housing 21 which contains the bearings making the pivot axis 16 operable. The brake member 23 as shown in fig. 5 is adapted to engage the drive wheels 1a,b by means of an engaging member 24 operably mounted to the brake member 23. According to the embodiment shown, the brake member 23 is connected to the control assembly 20, however it is equally conceivable that the brake member 23 is connected to its own control assembly.

**[0033]** Fig. 5 further shows the operable cylinder also described in fig. 4 for raising the drive wheels 1a,b above the ground surface. The operable cylinder 18 is here fixated to a support bar 25 fixated to the right 6a and left 6b bogie base members and to the height adjustable cylinder 11 and thus, when extended, raises the drive

wheels 1a,b above the ground surface.

**[0034]** According to a further extension of the embodiments shown above the manually propelled drive wheels 1a,b are assisted by an electrical motor, and according to one embodiment the work chair comprises two individual electrical motors in connection with each of the right 1a and left 1b drive wheels.

**[0035]** Please note that any embodiment or part of embodiment, feature, described herein may be combined in any way.

## Claims

1. A work chair comprising:
  - a. at least one first support wheel,
  - b. at least one second support wheel,
  - c. at least two drive wheels (1a,b), and
  - d. a height adjustable seat (9) fixated to a base part, wherein said first or second support wheel is adapted to be a rearward support wheel (3a, b), and the other of said first and second support wheel is adapted to be a forward support wheel (2a,b), wherein said work chair further comprises a bogie base member (6a,b), **characterized in that**
    - i. said at least two drive wheels (1a,b) are rotatably fixated to said bogie base member (6a,b), at a first fixation point,
    - ii. said at least one first support wheel (3a, b) is rotatably fixated to said bogie base member (6a,b), at a second fixation point,
    - iii. said at least one second support wheel is fixated to said base part, and
    - iv. said bogie base member (6a,b) is adapted to have a pivot axis (16), fixating the bogie base member to the base part, substantially between said first fixation point and said second fixation point.
2. The work chair according to claim 1, further comprising a break member (13) adapted to engage the ground surface.
3. The work chair according to claim 2, wherein said break (13) member comprises a material different from the materials of said at least one rearward support wheel (3a,b), said at least one forward support wheel (2a,b), and said at least two drive wheels (1a, b).
4. The work chair according to any one of claims 2 and 3, wherein said break member (13) is adapted to be operable.
5. The work chair according to claim 4, wherein said

operable break member (13) is adapted to be operable using a force selected from a list consisting of: mechanical force, hydraulic force and pneumatic force.

6. The work chair according to any one of the preceding claims, wherein said height adjustable seat (9) is electrically height adjustable.
7. The work chair according to any one of the preceding claims, wherein at least one of said at least one rearward support wheel (3a,b), and said at least one forward support wheel (2a,b), is a swiveling castor.
8. The work chair according to any one of the preceding claims, further comprising a lifting device (18) adapted to lift the drive wheels (1a,b) to a point at which the drive wheels (1a,b) do not engage the ground surface.
9. The work chair according to claim 8, wherein said lifting device (18) is an electrically powered lifting device.
10. The work chair according to claim 8, wherein said lifting device (18) is a lifting device selected from a group consisting of: pneumatic lifting devices, hydraulic lifting devices and mechanical lifting devices.
11. The work chair according to any one of the preceding claims, wherein the diameter of said drive wheels (1a,b) is larger than the diameter of said support wheels (2a,b; 3a,b).
12. The work chair according to claim 12, wherein the diameter of said drive wheels (1a,b) is at least 2 times as large as the diameter of said support wheels (2a, b; 3a,b).
13. The work chair according to claim 12, wherein the diameter of said drive wheels (1a,b) is at least 4 times as large as the diameter of said support wheels (2a, b; 3a,b).

#### Patentansprüche

1. Arbeitsstuhl, umfassend:
  - a. mindestens ein erstes Stützrad,
  - b. mindestens ein zweites Stützrad,
  - c. mindestens zwei Antriebsräder (1a,b) und
  - d. einen höhenverstellbaren Sitz (9), der an einem Gestell befestigt ist, wobei das erste oder zweite Stützrad darauf abgestimmt ist, ein hinteres Stützrad (3a,b) zu sein und das andere, erste oder zweite, Stützrad darauf abgestimmt ist, ein vorderes Stützrad (2a,b) zu sein, wobei

der Arbeitsstuhl ferner ein Fahrgestell-Trägerelement (6a,b) umfasst, **dadurch gekennzeichnet, dass**

- 5 i. die mindestens zwei Antriebsräder (1a,b) an einem ersten Befestigungspunkt drehbar an dem Fahrgestell-Trägerelement (6a, b) befestigt sind,
- ii. das mindestens eine erste Stützrad (3a, b) an einem zweiten Befestigungspunkt drehbar an dem Fahrgestell-Trägerelement (6a,b) befestigt ist,
- iii. das mindestens eine zweite Stützrad an dem Gestell befestigt ist, und
- iv. das Fahrgestell-Trägerelement (6a,b) darauf abgestimmt ist, eine Schwenkachse (16), mit der das Fahrgestell-Trägerelement an dem Gestell befestigt ist, im Wesentlichen zwischen dem ersten Befestigungspunkt und dem zweiten Befestigungspunkt aufzuweisen.
2. Arbeitsstuhl nach Anspruch 1, ferner umfassend ein Bremsenelement (13), das darauf abgestimmt ist, die Bodenfläche zu berühren.
3. Arbeitsstuhl nach Anspruch 2, wobei das Bremsenelement (13) ein Material umfasst, das sich vom Material des mindestens einen hinteren Stützrads (3a,b), des mindestens einen vorderen Stützrads (2a,b) und der mindestens zwei Antriebsräder (1a,b) unterscheidet.
4. Arbeitsstuhl nach einem der Ansprüche 2 und 3, wobei das Bremsenelement (13) darauf abgestimmt ist, einsetzbar zu sein.
5. Arbeitsstuhl nach Anspruch 4, wobei das einsetzbare Bremsenelement (13) darauf abgestimmt ist, unter Verwendung einer Kraft einsetzbar zu sein, die aus einer Liste bestehend aus mechanischer Kraft, hydraulischer Kraft und pneumatischer Kraft ausgewählt ist.
- 45 6. Arbeitsstuhl nach einem der vorhergehenden Ansprüche, wobei der höhenverstellbare Sitz (9) elektrisch höhenverstellbar ist.
7. Arbeitsstuhl nach einem der vorhergehenden Ansprüche, wobei das mindestens eine hintere Stützrads (3a,b) und/oder das mindestens eine vordere Stützrad (2a,b) eine Lenkrolle ist.
- 50 8. Arbeitsstuhl nach einem der vorhergehenden Ansprüche, ferner umfassend eine Hebevorrichtung (18), die darauf abgestimmt ist, die Antriebsräder (1a,b) bis zu einem Punkt anzuheben, an dem die Antriebsräder (1 a,b) die Bodenfläche nicht berühren.

ren.

9. Arbeitsstuhl nach Anspruch 8, wobei die Hebevorrichtung (18) eine elektrisch betriebene Hebevorrichtung ist.

10. Arbeitsstuhl nach Anspruch 8, wobei die Hebevorrichtung (18) eine Hebevorrichtung ist, die aus einer Gruppe bestehend aus pneumatischen Hebevorrichtungen, hydraulischen Hebevorrichtungen und mechanischen Hebevorrichtungen ausgewählt ist.

11. Arbeitsstuhl nach einem der vorhergehenden Ansprüche, wobei der Durchmesser der Antriebsräder (1 a,b) größer als der Durchmesser der Stützräder (2a,b; 3a,b) ist.

12. Arbeitsstuhl nach Anspruch 12, wobei der Durchmesser der Antriebsräder (1a,b) mindestens doppelt so groß wie der Durchmesser der Stützräder (2a,b; 3a,b) ist.

13. Arbeitsstuhl nach Anspruch 12, wobei der Durchmesser der Antriebsräder (1a,b) mindestens viermal so groß wie der Durchmesser der Stützräder (2a,b; 3a,b) ist.

## Revendications

1. Chaise de travail comprenant :

- a. au moins une première roue de support,
- b. au moins une seconde roue de support,
- c. au moins deux roues d'entraînement (1a, b), et

d. un siège réglable en hauteur (9) fixé sur une partie de base, ladite première ou seconde roue de support étant adaptée pour être une roue de support arrière (3a, b), et l'autre desdites première et seconde roues de support est adaptée pour être une roue de support avant (2a, b), ladite chaise de travail comprenant en outre un élément de base de bogie (6a, b), **caractérisée en ce que**

i. lesdites au moins deux roues d'entraînement (1a, b) sont fixées de manière rotative audit élément de base de bogie (6a, b) à un premier point de fixation,

ii. ladite au moins une première roue de support (3a, b) est fixée de manière rotative audit élément de base de bogie (6a, b) à un second point de fixation,

iii. ladite au moins une seconde roue de support est fixée à ladite partie de base, et

iv. ledit élément de base de bogie (6a, b) est adapté pour avoir un axe de pivotement

(16), fixant l'élément de base de bogie à la partie de base, sensiblement entre ledit premier point de fixation et ledit second point de fixation.

2. Chaise de travail selon la revendication 1, comprenant en outre un élément de frein (13) adapté pour être en prise avec la surface du sol.

3. Chaise de travail selon la revendication 2, dans laquelle ledit élément de frein (13) comprend un matériau différent des matériaux de ladite au moins une roue de support arrière (3a, b), de ladite au moins une roue de support avant (2a, b), et desdites au moins deux roues d'entraînement (1a, b).

4. Chaise de travail selon l'une quelconque des revendications 2 et 3, dans laquelle ledit élément de frein (13) est adapté pour être actionnable.

5. Chaise de travail selon la revendication 4, dans laquelle ledit élément de frein (13) actionnable est adapté pour être actionnable en utilisant une force sélectionnée dans une liste constituée de : force mécanique, force hydraulique et force pneumatique.

6. Chaise de travail selon l'une quelconque des revendications précédentes, dans laquelle ledit siège réglable en hauteur (9) est réglable en hauteur électriquement.

7. Chaise de travail selon l'une quelconque des revendications précédentes, dans laquelle au moins une de ladite au moins une roue de support arrière (3a, b) et de ladite au moins une roue de support avant (2a, b) est une roulette pivotante.

8. Chaise de travail selon l'une quelconque des revendications précédentes, comprenant en outre un dispositif de levage (18) adapté pour lever les roues d'entraînement (1 a, b) jusqu'à un point auquel les roues d'entraînement (1 a, b) ne sont pas en prise avec la surface du sol.

9. Chaise de travail selon la revendication 8, dans laquelle ledit dispositif de levage (18) est un dispositif de levage à alimentation électrique.

10. Chaise de travail selon la revendication 8, dans laquelle ledit dispositif de levage (18) est un dispositif de levage sélectionné dans un groupe constitué de :

dispositifs de levage pneumatiques, dispositifs de levage hydrauliques et dispositifs de levage mécaniques.

11. Chaise de travail selon l'une quelconque des revendications précédentes, dans laquelle le diamètre

desdites roues d'entraînement (1a, b) est supérieur au diamètre desdites roues de support (2a, b ; 3a, b).

- 12.** Chaise de travail selon la revendication 12, dans laquelle le diamètre desdites roues d'entraînement (1a, b) est au moins deux fois plus grand que le diamètre desdites roues de support (2a, b ; 3a, b). 5
- 13.** Chaise de travail selon la revendication 12, dans laquelle le diamètre desdites roues d'entraînement (1a, b) est au moins quatre fois plus grand que le diamètre desdites roues de support (2a, b ; 3a, b). 10

15

20

25

30

35

40

45

50

55

Fig.1

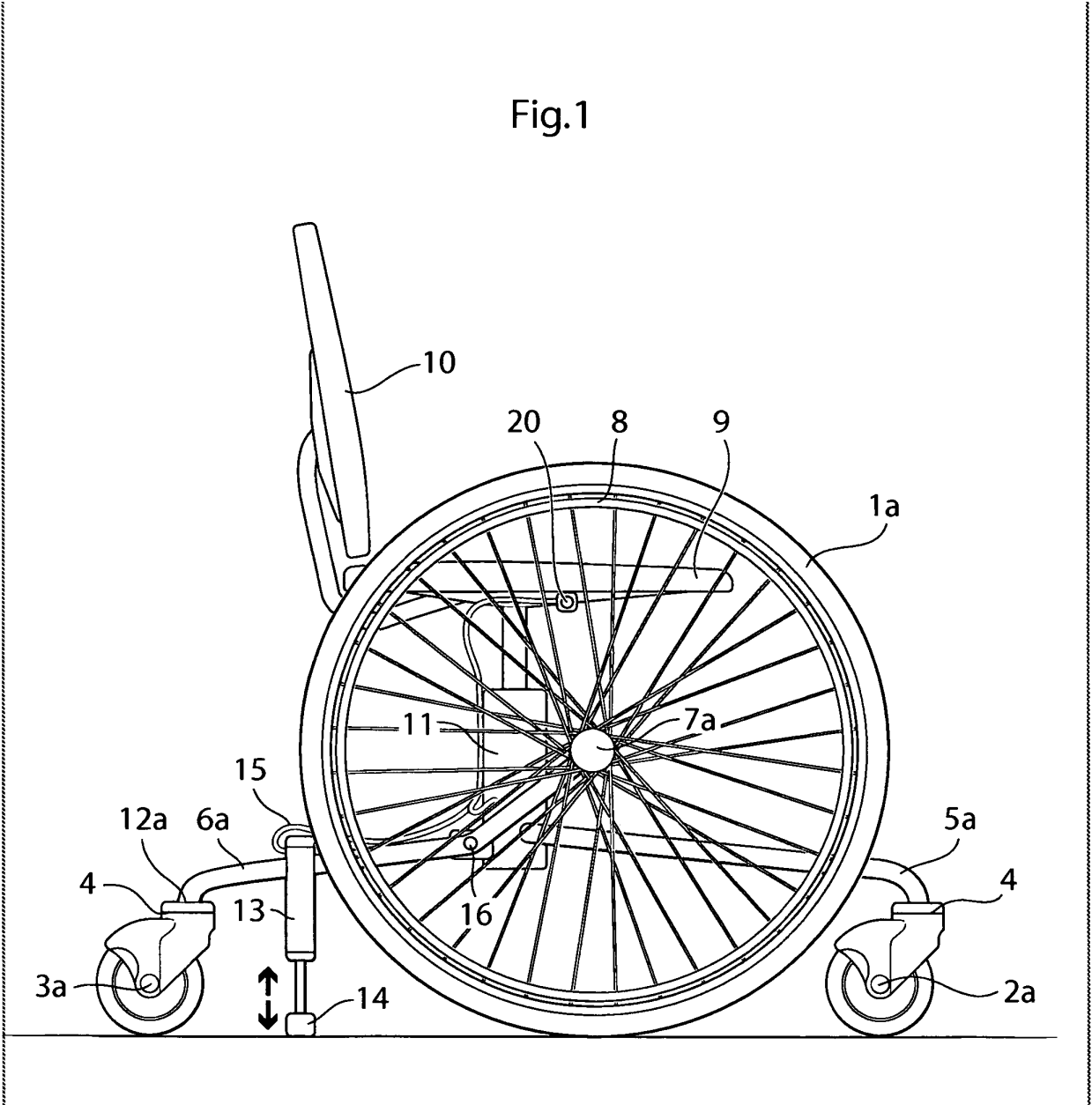

Fig.2

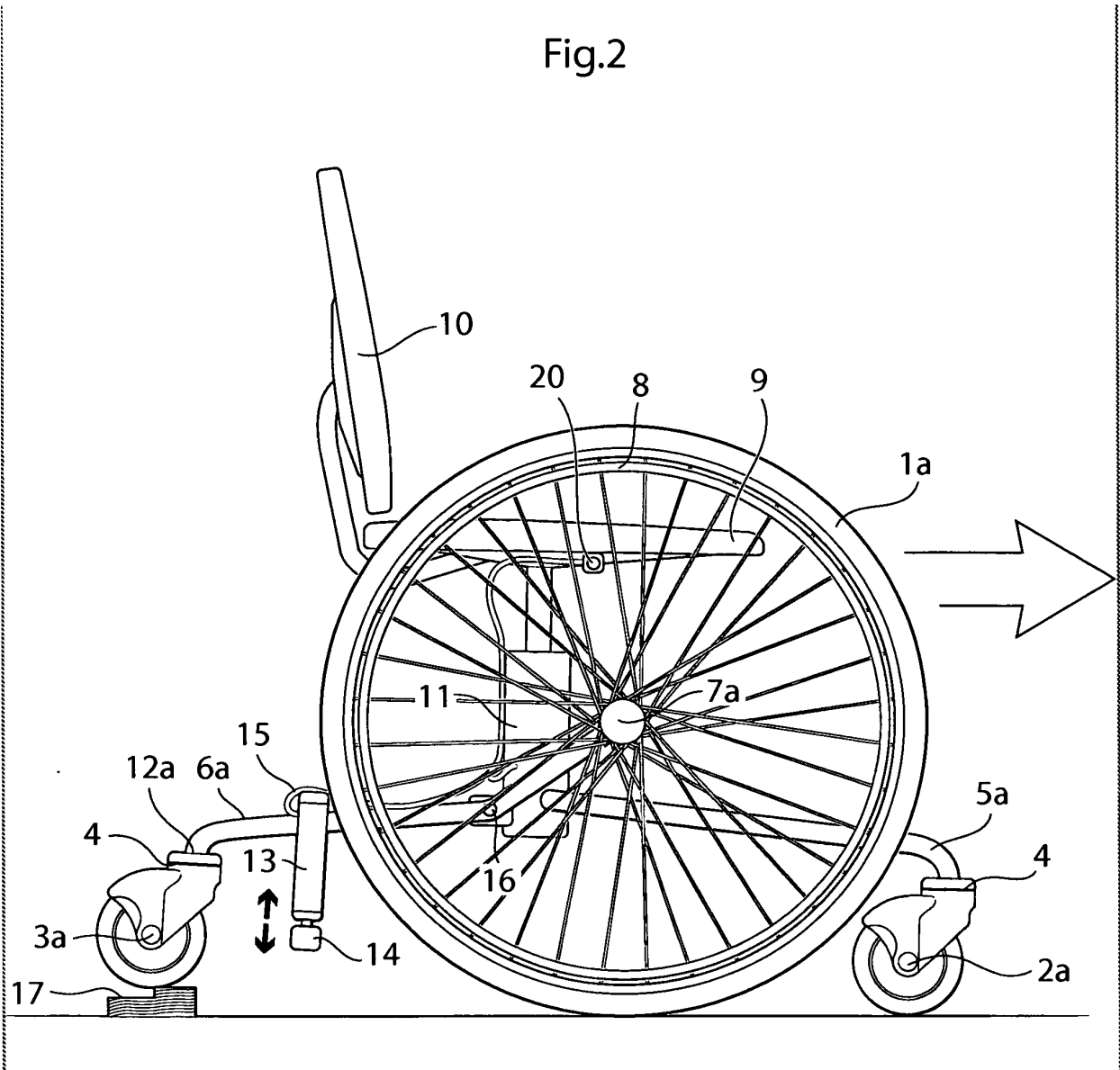
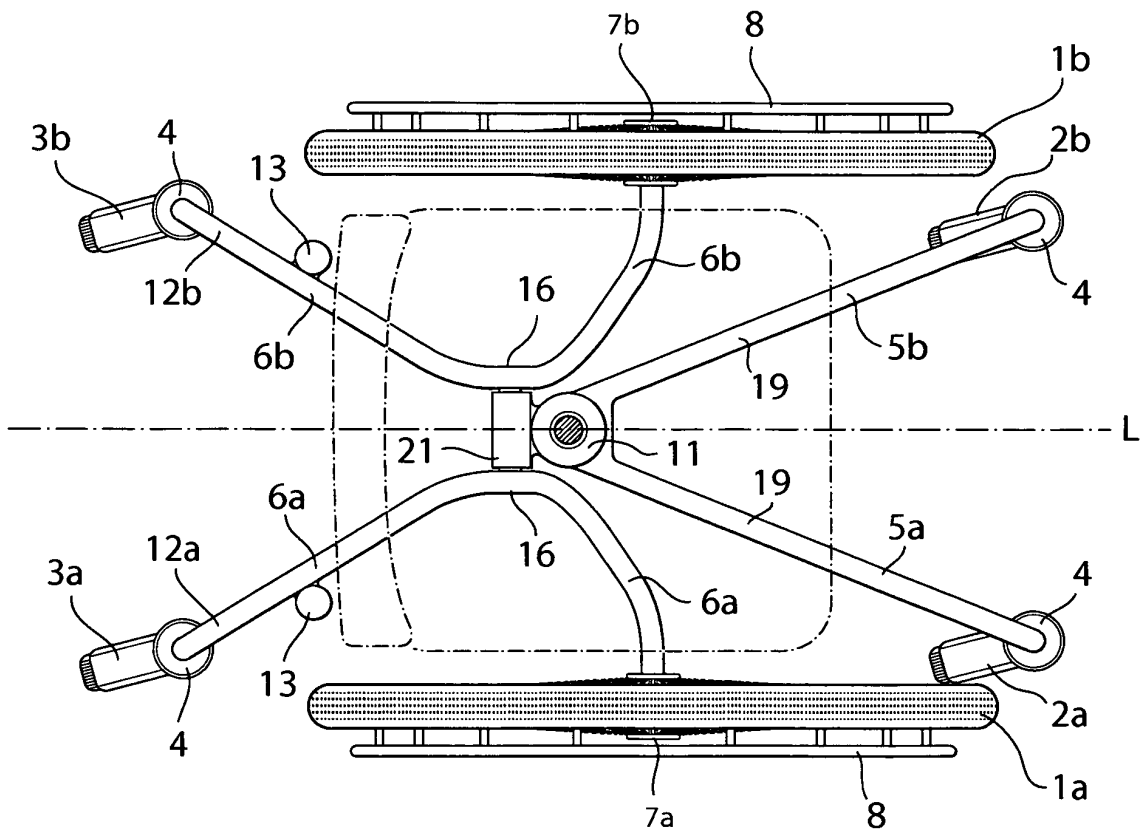

Fig.3







**REFERENCES CITED IN THE DESCRIPTION**

*This list of references cited by the applicant is for the reader's convenience only. It does not form part of the European patent document. Even though great care has been taken in compiling the references, errors or omissions cannot be excluded and the EPO disclaims all liability in this regard.*

**Patent documents cited in the description**

- US 20070216131 A [0004]