

(19) World Intellectual Property Organization  
International Bureau



(43) International Publication Date  
15 November 2001 (15.11.2001)

PCT

(10) International Publication Number  
**WO 01/86802 A2**

- (51) International Patent Classification<sup>7</sup>: **H02P 9/04** [CA/CA]; 1475 Bourbeau, Saint-Bruno, Quebec J3V 4L4 (CA).
- (21) International Application Number: PCT/CA01/00670
- (22) International Filing Date: 11 May 2001 (11.05.2001)
- (25) Filing Language: English
- (26) Publication Language: English
- (30) Priority Data:  
60/203,588 11 May 2000 (11.05.2000) US  
09/645,567 25 August 2000 (25.08.2000) US
- (71) Applicant (for all designated States except US): **BOMBARDIER INC.** [CA/CA]; 800 Rene-Levesque Boulevard West, 29th Floor, Montreal, Quebec H3B 1Y8 (CA).
- (74) Agents: **MCGRAW, James** et al.; Smart & Biggar, P.O. Box 2999, Station D, 900-55 Metcalfe Street, Ottawa, Ontario K1P 5Y6 (CA).
- (81) Designated States (national): CA, US.
- (84) Designated States (regional): European patent (AT, BE, CH, CY, DE, DK, ES, FI, FR, GB, GR, IE, IT, LU, MC, NL, PT, SE, TR).
- Published:**  
— without international search report and to be republished upon receipt of that report

For two-letter codes and other abbreviations, refer to the "Guidance Notes on Codes and Abbreviations" appearing at the beginning of each regular issue of the PCT Gazette.

- (72) Inventor; and  
(75) Inventor/Applicant (for US only): **SOUCY, Richard**

(54) Title: SYSTEM, METHOD AND APPARATUS FOR POWER REGULATION

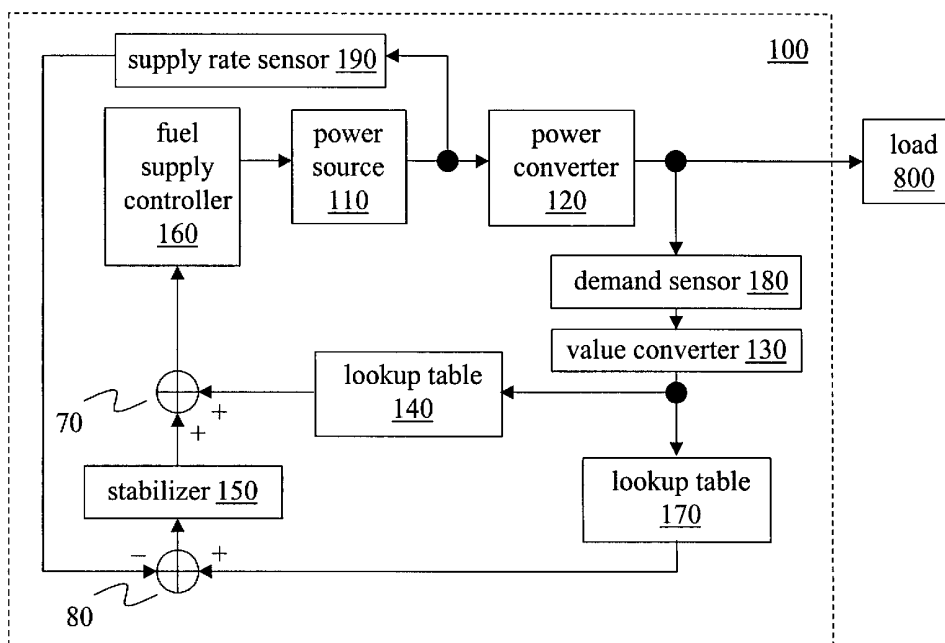

(57) Abstract: By controlling a power source in response to a load power demand, more efficient operation is obtained. Faster response is also realized by incorporating a compensation for inertia in the path between the power source and the load. In one exemplary embodiment, a further-driven system for electric power generation is controlled according to increased values of a load power demand and a turbine output shaft speed.

WO 01/86802 A2

## SYSTEM, METHOD, AND APPARATUS FOR POWER REGULATION

## BACKGROUND OF THE INVENTION

## 1. Field of the Invention

5 This invention relates to power regulation. More specifically, this invention relates to control of a power source based at least in part on a power demand by a load.

## 2. Description of Related Art

FIGURES 1 and 2 show two conventional systems for  
10 power generation. In FIGURE 1, an engine produces mechanical power that is inputted to a generator. For example, the engine may rotate a shaft that is coupled to the generator (possibly through a gearbox or transmission). The generator converts the mechanical power to electrical power that supplies a load. In  
15 response to an error between a predetermined engine speed output, and an actual engine output speed as measured by a speed sensor, a governor provides a command to a fuel supply controller, which controls the supply of fuel to the engine. Because the control of the engine is based upon the engine  
20 output speed, this type of control system may be called a speed reactive system.

A generator as shown in the system of FIGURE 1 may produce electricity in either an alternating current (a.c.) or direct current (d.c.) form, depending on the requirements of  
25 the load. If a.c. is required, then the frequency of the current supplied by the generator must typically be regulated to within a small margin in order to avoid damage to the load. In the United States and Canada, e.g., a.c. current is typically maintained at 60 Hz. Because the rotational speed of

the generator rotor determines the frequency of the electrical power produced, it is essential that the speed of the engine be regulated to a constant value.

Even if the load requires d.c. from the generator  
5 (possibly supplied via a rectifier or inverter), it may also be important to regulate the speed of the engine. In this case, the voltage of the d.c. output by the generator depends upon the speed of the engine. Although small variations in output voltage (i.e., ripples) may be filtered out, avoiding damage to  
10 the load will typically require that an average voltage output of the generator (and hence an average speed of the engine) be kept constant. That is, even though the pre-determined engine speed for a system according to FIGURE 1 may yield good results over a broad range of conditions with respect to some criterion  
15 (e.g., minimal fuel consumption), one single value will typically be sub-optimal with respect to changes in such variables as pressure, temperature, and load power demand. Because fuel costs may account for 80% of the operating costs of such a system, increasing efficiency by even a few percent  
20 may result in a considerable cost savings.

Another shortcoming of speed reactive systems is that they operate without any knowledge of the power actually demanded by the load. Because the system reacts only to the engine output speed, its response is slowed by the inertia of  
25 the moving components in the power generation path, as no command with respect to speed may be met until the components are accumulated or decelerated as necessary.

FIGURE 2 shows another system for engine speed regulation that is used, for example, in propeller-driven  
30 aircraft. In this system, it is also desirable to maintain engine output at a constant speed. An operator varies the

power supplied by the engine to the load by commanding the final supply controller to adjust the supply of fuel to the engine. In order to maintain a constant engine output speed another controller varies the characteristics of the load. In response to a speed increase (possibly due to a command to increase power),, for example, the controller may vary the pitch of the propeller, thereby increasing torque and maintaining a constant engine speed. For a given output speed, however, an engine will typically perform optimally (for example, with respect to fuel consumption) at only one particular power output value. Therefore, a control system as shown in FIGURE 2 may also perform sub-optimally during much of its operation.

#### SUMMARY

In a system, method, and apparatus for power regulation as disclosed herein, a load power demand value determines a power supply behavior that is optimal with respect to some criterion (e.g., fuel consumption). Such a system, method and apparatus also complies with load demand requirements more quickly and efficiently than existing approaches.

#### BRIEF DESCRIPTION OF THE DRAWINGS

FIGURE 1 shows a speed reactive system;

FIGURE 2 shows a conventional power generation system;

FIGURE 3 shows a block diagram for a system according to an embodiment of the invention;

FIGURE 4 shows a block diagram for a system according to an exemplary embodiment of the invention;

FIGURE 5 shows a system according to an exemplary embodiment of the invention;

FIGURE 6 shows a system according to an embodiment of the invention;

5           FIGURE 7 shows a block diagram for a system according to an embodiment of the invention;

FIGURE 8 shows a block diagram for a system according to an embodiment of the invention;

10           FIGURE 9 shows a block diagram for a system according to an embodiment of the invention;

FIGURE 10 shows a block diagram for a system according to an embodiment of the invention;

FIGURE 11 shows a block diagram for an apparatus according to an embodiment of the invention; and

15           FIGURE 12 shows a block diagram for an apparatus according to an embodiment of the invention.

#### DETAILED DESCRIPTION

As shown in FIGURE 3, system 100 according to an embodiment of the invention includes a power source 110 which  
20 supplies power through power converter 120 to drive a load 800. Demand sensor 180 senses the power consumed by the load. Value converter 130 receives the observed power consumption value and projects the power output that power source 110 must produce in order to meet the load demand. This power supply requirement  
25 value is outputted to lookup tables 140 and 170.

Lookup table 140 maps the power supply requirement value to a power demand value. A value based at least on part

on this power demand value is inputted to fuel supply controller 160, which controls the supply of fuel to power source 110 accordingly. Lookup table 170 maps the power supply requirement value to a rate target value. After an observed  
5 rate value as indicated by supply rate sensor 190 is subtracted from the rate target value, the resulting rate error value is inputted to stabilizer 150, which produces an inertia compensation value. The power demand value is modified by this inertia compensation value, and the modified power demand value  
10 is inputted to fuel supply controller 160.

Power source 110 receives fuel via fuel supply controller 160 and produces power. This power, which is inputted to power converter 120, may be produced as mechanical energy, as thermal energy or as some other form of energy.  
15 Power source 110 may be an engine 210, as shown in FIGURE 4, such as a diesel engine. In an exemplary implementation, as shown in FIGURE 5, power source 110 is a gas turbine 212 which consumes a fossil fuel (e.g., diesel fuel) received via fuel supply controller 160 and which produces mechanical power by  
20 turning a drive shaft. In a particular implementation, the operation of gas turbine 212 is characterized by a speed of a compressor and a speed of a turbine output shaft, which need not be linked except by thermodynamic pressure. Turbine 212 may have several compressors and/or output shafts, and turbine  
25 212 may also be of another type such as a vapor or steam turbine.

Power converter 120 converts the power received from power source 110 into a form as required by load 400. For example, this conversion may be from thermal to electrical  
30 power, or from electrical to mechanical power, or from thermal to mechanical power. In one implementation of the invention, power converter 120 comprises a generator that receives

mechanical power outputted by power source 110 (e.g., by turning a drive shaft) and converts it into electrical power. In an exemplary implementation, power converter 120 comprises two or more generators and a gearbox that receives the  
5 mechanical power and distributes it among the generators in predetermined proportion. Power converter 120 may also include rectifiers, inverters, and/or filters to produce an output in the form required by load 800. In the exemplary  
10 implementations of FIGURES 4 and 5, electrical load 810 may comprise one or more motors which propel a fuel-powered locomotive that incorporates a system as described herein.

Demand sensor 180 outputs an observed power consumption value that relates to the power demand of load 800. This demand value may be expressed, for example, as watts or  
15 Joules. In the exemplary implementations of FIGURES 4 and 5, demand sensor 180 outputs a signal that relates to a level of electrical power demanded by electrical load 810. For example, demand sensor 180 may include one or more voltage sensors and one or more current sensors, wherein a power demand value  
20 corresponding to a particular component of electrical load 810 is obtained by multiplying together corresponding voltage and current values. Values may be sensed or outputted by demand sensor 180 according to a given digital sampling rate, for example, 50 Hz.

25 In a case where load 800 consumes thermal power (i.e., for heating and/or for cooling), demand sensor 180 may produce a value relating to a difference between a temperature of a component of load 800 and an ambient or a desired temperature. As above, the sensing and/or the output of values  
30 by the demand sensor 180 may be either analog or digital.

Value converter 130 receives the observed power consumption value from demand sensor 180 and produces a power supply requirement value in response. The power supply requirement value represents a projection of the power that power source 110 must supply in order to meet the load demand. In one implementation, value converter 130 produces the power supply requirement value by applying an efficiency reciprocal function to the observed power consumption value, wherein the efficiency reciprocal function represents the inverse of the efficiency of conversion of power converter 120. In this way, an estimate of the level of power output by power source 110 that will produce the load power demand at the output of energy converter 120 may be obtained. In a case where the efficiency reciprocal function may be expressed as a constant factor (i.e., the relationship between power inputted to and power outputted by power converter 120 is linear), value converter 130 may be constructed as a constant multiplier. In another case (e.g., for a more complex relationship), value converter 130 may comprise one or more lookup tables whereby a particular demand level may be interpolated to a corresponding power supply requirement. In the exemplary implementations of FIGURES 4 and 5, value converter 130 may compensate for the efficiency of one or more generators, gear boxes, rectifiers, inverters, and/or other components that may appear in the power path between the output of power source 110 and the input of electrical load 810.

Lookup table 170 receives the power supply requirement value produced by value converter 130 and outputs a corresponding rate target value. The map between the input power value and the output rate value that characterizes lookup table 170 may be optimized according to a particular criterion such as fuel consumption, emissions production, operating temperature, etc. In an exemplary implementation, for example,

lookup table 170 applies a map that is optimized for minimum fuel consumption.

The relationship mapped by lookup table 170 may be a function of one or more other values as well. For example, a performance of a turbine 212 may also depend on a temperature of the air at the compressor intake, as the density of air may change dramatically with large changes in temperature. Similarly, large changes in altitude may also result in air changes in the ambient air pressure that will affect air density as well. Therefore, lookup table 170 may be implemented as a matrix of tables. Each such table may indicate a different mapping of power to rate, and the choice between the tables may be determined by sensed operating parameters such as air pressure and temperature, fuel characteristics, etc.

Supply rate sensor 190 outputs an observed rate value that relates to the rate of energy supply by power source 110. In the exemplary implementations of FIGURES 4 and 5, supply rate sensor 190 is implemented as a speed sensor 290 and outputs a value obtained by sampling (at a rate of 50 Hz) the rotational position or speed of a drive shaft driven by power source 110. In this case, the value outputted by speed sensor 290 relates to a speed of the drive shaft in revolutions per minute (rpm).

In adder 80, the observed rate value produced by supply rate sensor 190 is subtracted from the rate target value outputted by lookup table 170 to obtain a rate error value. Stabilizer 150 receives the rate error value and outputs an inertia compensation value according to one or more predetermined stabilization profiles. In an exemplary implementation, stabilizer 150 is a governor 250 that is

implemented as a proportional-integral controller. The operation of such a controller is characterized by a proportional gain  $K_p$  and an integral gain  $K_i$ . Proportional-integral controllers tend to decrease rise time and steady state error while increasing overshoot. Other forms of controllers (such as proportional, derivative, or proportional-integral-derivative) may also be used for stabilizer 150 if different performance characteristics are desired. Although incorporating a derivative gain allows a system to reach the steady state sooner, such controllers also tend to add noise to the system. In exemplary implementations of FIGURES 4 and 5, the extra response provided by incorporating a derivative gain has not been necessary in practice.

Lookup table 140 receives the power supply requirement value produced by value converter 130 and produces the power demand value. In the exemplary implementation of FIGURES 4 and 5, the power demand value relates to a speed of a compressor of a turbine 212, which speed is strongly correlated with turbine output power.

As with lookup table 170, the relationship between power and speed, for example, that is mapped by lookup table 140 may depend on other operating parameters such as pressure and temperature as well. Therefore, lookup table 140 may be similarly implemented as a matrix of (e.g., 64) tables, wherein sensed values of such other operating parameters are used to select the desired mapping.

Fuel supply controller 160 receives the modified power demand value outputted by adder 70 and adjusts the supply of fuel to power source 110, accordingly. In the exemplary implementations of FIGURES 4 and 5, fuel supply controller 160 monitors the speed of a compressor of turbine 212, and adjusts

the fuel supply such that the compressor speed complies with the modified power demand value. In another implementation, fuel supply controller 160 may control the fuel supply based upon other monitored values in order to maintain a desired  
5 correspondence between the modified power demand value and the operation of power source 110.

Because of the quick feedback path provided through lookup table 140, system 100 may adapt quickly to meet changes in the load demand level, thereby reducing both response time  
10 and fuel consumption. In the exemplary implementation of FIGURES 4 and 5, because the power demand value is modified by the inertia compensation value before it is inputted to fuel supply controller 160, the inertia encountered by the generated power in transfer from power source 110 to load 800 may be  
15 counteracted by increasing or decreasing the power demand value as appropriate. In these exemplary implementations, inertia is encountered in attempting to change the speed of the turbine output shaft, the components of the gear box, and the components of the generator, for example.

20

When adder 80 returns a positive value (i.e., the speed of the output shaft of turbine 212 is insufficient to support the power demand of electrical load 810), an augmented power demand value is inputted to fuel supply controller 160 in  
25 order to accelerate the inertial components more quickly to the desired speed. When the value outputted by adder 80 is negative (i.e., the turbine output speed is higher than the power demanded by electrical load 810 requires), then a reduced power demand value is inputted to fuel supply controller 160  
30 such that the load may pull part of the required power out of the inertial components and thereby decelerate them to the appropriate speed more quickly.

FIGURE 6 is a block diagram of a system according to an alternative embodiment of the invention. In this embodiment, override 320 inputs a minimum rate requirement B to maximum function block 310. Maximum function block 310 outputs the maximum between the override rate B and the rate target value outputted by lookup table 170. Such an embodiment may be used in a case where a minimum rate is desired or required, regardless of the power demand of load 800. In the exemplary implementations of FIGURES 4 and 5, for example, it may be necessary to operate a generator at a minimum speed, regardless of the power drawn by electrical load 810. It is possible that the additional mode of operation described in FIGURE 6 may only be initiated in the case of a malfunction of one or more components of load 800.

Because the relationship between power and rate which is mapped in lookup table 140 may be nonlinear, it may not be desirable to use fixed values for Kp and Ki in stabilizer 150. Kp and Ki values which are appropriate at low values of low power demand, for example, may not be appropriate at high levels of demand, due in part to this nonlinearity. In the alternative implementation shown in FIGURE 7, such a difficulty may be avoided by moving the conversion from power to rate performed in lookup table 140 to a point subsequent to the summation in adder 70. In this case, stabilizer 450 converts the rate error value into an inertia compensation value that relates to power rather than rate. As a consequence, fixed values of Kp and Ki may be used in stabilizer 450. Lookup table 440 may be adjusted as necessary to perform the new mapping or mappings. Alternatively, as shown in the embodiment of FIGURE 8, the rate values may be squared in squaring function blocks 460 and 470 before differentiation in adder 80. In this case, stabilizer 452 performs a similar conversion with possibly different fixed values of Kp and Ki. Because of the

squaring of the rate values, the value outputted by stabilizer 452 bears a closer resemblance to power; and, therefore, it is possible in the implementation to use the same mappings in lookup table 140.

5           As shown in FIGURES 9 and 10, the modification described in FIGURE 6 may be combined with the modifications shown in FIGURES 7 and 8.

FIGURE 11 shows an apparatus 105 according to an embodiment of the invention. This apparatus may be constructed  
10 and supplied separately from power source 110 and power converter 120 for use with possibly different power generation systems. Similarly, the apparatus shown in FIGURE 12 may be used to perform a function similar to that of the system shown in FIGURE 8.

15           The foregoing presentation of the described embodiments is provided to enable any person skilled in the art to make or use the present invention. Various modifications to these embodiments are possible, and the generic principles presented herein may be applied to other embodiments as well.  
20 For example, the invention may be implemented in part or in whole (as appropriate to the particular embodiment) as a hard-wired circuit or as a circuit configuration fabricated into an application-specific integrated circuit or field-programmable gate array. Likewise, the invention may be implemented in part  
25 or in whole as a firmware program loaded or fabricated into non-volatile storage (such as read-only memory or flash memory) as machine-readable code, such code being instructions executable by an array of logic elements such as a microprocessor or other digital signal processing unit.  
30 Further, the invention may be implemented in part or in whole as a software program loaded as machine-readable code from or

into a data storage medium such as a magnetic, optical,  
magneto-optical, or phase-change disk or disk drive; a  
semiconductor memory; or a printed bar code. Thus, the present  
invention is not intended to be limited to the embodiments  
5 shown above but rather is to be accorded the widest scope  
consistent with the principles and novel features disclosed in  
any fashion herein.

CLAIMS:

1. A method comprising:
  - obtaining a power supply requirement value;
  - producing an inertia compensation value; and
  - 5 modifying a power demand value with said inertia compensation value to produce a modified power demand value, wherein said power supply requirement value is expressible in units of watts, and
  - wherein said power demand value is based at least in
  - 10 part on said power supply requirement value, and
  - wherein said inertia compensation value is based at least in part on said power supply requirement value, and
  - wherein said modifying comprises adding a value based at least in part on said inertia compensation value to a value
  - 15 based at least in part on said power demand value.
2. The method according to claim 1, said method further comprising mapping said power supply requirement value to a rate target value, said inertia compensation value being based at least in part on said rate target value.
- 20 3. The method according to claim 2, wherein said mapping varies at least in part according to a temperature.
4. The method according to claim 2, wherein said mapping varies at least in part according to a density.
5. The method according to claim 2, said method further
- 25 comprising constraining said rate target value to be not less than a predetermined minimum rate target value.

6. The method according to claim 2, wherein producing an inertia compensation value comprises stabilizing a compensating value, wherein said compensating value is based at least in part on said rate target value and an observed rate value.

5 7. The method according to claim 6, wherein said stabilizing said compensating value comprises applying at least one among a proportional gain and an integral gain to a value based at least in part on said compensating value.

8. The method according to claim 6, wherein at least one  
10 among said rate target value and said observed rate value is expressible as a velocity.

9. The method according to claim 6, wherein at least one among said rate target value and said observed rate value is expressible as an angular velocity.

15 10. The method according to claim 9, wherein said observed rate value relates to a rotational speed of an output shaft of a turbine.

11. The method according to claim 1, wherein said modified power demand value is expressible as a velocity.

20 12. The method according to claim 1, wherein said modified power demand value is expressible as an angular velocity.

13. The method according to claim 12, wherein said modified power demand value relates to a rotational speed of a  
25 compressor of a turbine.

14. The method according to claim 1, wherein said power supply requirement value is based at least in part on an observed power consumption value,

wherein said observed power consumption value relates to power consumed by at least one load.

15. The method according to claim 14, wherein said power supply requirement value relates to power produced by at least  
5 one generator.

16. The method according to claim 14, wherein said observed power consumption value relates to electrical power.

17. The method according to claim 14, wherein obtaining a power supply requirement value comprises applying an efficiency  
10 reciprocal function to said observed power consumption value.

18. The method according to claim 17, wherein said applying an efficiency reciprocal function comprises mapping said observed power consumption value to said power supply requirement value according to said efficiency reciprocal  
15 function.

19. The method according to claim 18, wherein said mapping said power supply requirement value to said observed power consumption value according to said efficiency reciprocal function comprises multiplying said observed power consumption  
20 value by an efficiency reciprocal factor.

20. The method according to claim 1, wherein said power demand value is substantially the same value as said power supply requirement value, and

wherein said modified power demand value is based at  
25 least in part on a compensated power demand value,

wherein said compensated power demand value is a sum of a value based at least in part on said inertia compensation

value and a value based at least in part on said power demand value.

21. The method according to claim 20, said method further comprising mapping said compensated power demand value to said  
5 modified power demand value,

wherein said compensated power demand value is expressible in units of watts.

22. The method according to claim 6, wherein said compensating value is based at least in part on a square of  
10 said rate target value and a square of said observed rate value.

23. The method according to claim 6, wherein said compensating value is based at least in part on a difference of a square of said rate target value and a square of said  
15 observed rate value.

24. The method according to claim 2, said method further comprising combining said rate target value and an observed rate value to produce a compensating value, said inertia compensation value being based at least in part on said  
20 compensating value.

25. The method according to claim 24, wherein said compensating value comprises a difference of a value based at least in part on said observed rate value and a value based at least in part on said rate target value.

25 26. The method according to claim 24, wherein said producing an inertia compensation value comprises stabilizing said compensating value.

27. The method according to claim 24, wherein said stabilizing said compensating value comprises applying at least one among a proportional gain and an integral gain to a value based at least in part on said compensating value.

5 28. The method according to claim 27, wherein said at least one among a proportional gain and an integral gain varies in response to at least a magnitude of said compensating value.

29. The method according to claim 2, wherein at least one among said power demand value and said modified power demand  
10 value is expressible as a velocity.

30. The method according to claim 2, wherein at least one among said power demand value and said modified power demand value is expressible as an angular velocity.

31. The method according to claim 2, said method further  
15 comprising mapping said power supply requirement value to said power demand value,

wherein said mapping varies at least in part according to a temperature.

32. The method according to claim 2, said method further  
20 comprising mapping said power supply requirement value to said power demand value,

wherein said mapping varies at least in part according to a density.

33. An apparatus comprising:

25 an inertia compensation value producer configured and arranged to receive a power supply requirement value and to produce an inertia compensation value; and

a power demand value modifier configured and arranged to receive a power demand value and said inertia compensation value and to produce a modified power demand value,

wherein said power supply requirement value is  
5 expressible in units of watts, and

wherein said inertia compensation value is based at least in part on said power supply requirement value, and

wherein said power demand value modifier produces said modified power demand value at least in part by adding a  
10 value based at least in part on said inertia compensation value to a value based at least in part on said power demand value.

34. The apparatus according to claim 33, wherein said power demand value is based at least in part on said power supply requirement value.

15 35. The apparatus according to claim 33, wherein said inertia compensation value producer comprises a lookup table configured and arranged to map said power supply requirement value to a rate target value, and

wherein said inertia compensation value is based at least in  
20 part on said rate target value.

36. The apparatus according to claim 35, wherein said mapping varies at least in part according to a temperature.

37. The apparatus according to claim 35, wherein said  
25 mapping varies at least in part according to a density.

38. The apparatus according to claim 35, wherein said inertia compensation value producer further comprises a maximum

function block configured and arranged to constrain said rate target value to be not less than a predetermined minimum rate target value.

39. The apparatus according to claim 35, wherein said  
5 inertia compensation value producer further comprises a stabilizer configured and arranged to stabilize a compensating value,

wherein said compensating value is based at least in part on said rate target value and an observed rate value.

10 40. The apparatus according to claim 39, wherein said stabilizer comprises a proportional-integral controller.

41. The apparatus according to claim 39, wherein at least one among said rate target value and said observed rate value is expressible as a velocity.

15 42. The apparatus according to claim 39, wherein at least one among said rate target value and said observed rate value is expressible as an angular velocity.

43. The apparatus according to claim 42, wherein said  
20 observed rate value relates to a rotational speed of an output shaft of a turbine.

44. The apparatus according to claim 33, wherein said modified power demand value is expressible as a velocity.

45. The apparatus according to claim 33, wherein said  
25 modified power demand value is expressible as an angular velocity.

46. The apparatus according to claim 45, wherein said modified power demand value relates to a rotational speed of a compressor of a turbine.

47. The apparatus according to claim 33, wherein said apparatus further comprises a value converter configured and arranged to receive an observed power consumption value and to produce said power supply requirement value,

5 wherein said power supply requirement value is based at least in part on said observed power consumption value, and

wherein said observed power consumption value relates to power consumed by at least one load.

48. The apparatus according to claim 47, wherein said  
10 power supply requirement value relates to power produced by at least one generator.

49. The apparatus according to claim 47, wherein said observed power consumption value relates to electrical power.

50. The apparatus according to claim 47, wherein said  
15 value converter is further configured and arranged to apply an efficiency reciprocal function to said observed power consumption value.

51. The apparatus according to claim 50, wherein said  
20 value converter is further configured and arranged to map said observed power consumption value to said power supply requirement value according to said efficiency reciprocal function.

52. The apparatus according to claim 51, wherein said  
25 value converter is further configured and arranged to multiply said observed power consumption value by an efficiency reciprocal factor.

53. The apparatus according to claim 33, wherein said power demand value modifier comprises an adder configured and

arranged to receive a value based at least in part on said inertia compensation value and a value based at least in part on said power demand value and to produce a compensated power demand value, and

5            wherein said power demand value is substantially the same value as said power supply requirement value, and

          wherein said compensated power demand value is a sum of at least the value based at least in part on said inertia compensation value and the value based at least in part on said  
10 power demand value, and

          wherein said modified power demand value is based at least in part on said compensated power demand value.

54.        The apparatus according to claim 53, wherein said power demand value modifier further comprises a second lookup  
15 table configured and arranged to map said compensated power demand value to said modified power demand value, and

          wherein said compensated power demand value is expressible in units of watts.

55.        The apparatus according to claim 39, wherein said  
20 inertia compensation value producer further comprises a squaring function block configured and arranged to square at least one among said rate target value and said observed rate value, and

          wherein compensating value is based at least in part  
25 on a square of said rate target value and a square of said observed rate value.

56.        The apparatus according to claim 55, wherein said compensating value is based at least in part on a difference of

a square of said rate target value and a square of said observed rate value.

57. The apparatus according to claim 35, wherein said inertia compensation value producer further comprises a  
5 combiner configured and arranged to receive and combine at least a value based at least in part on said rate target value and a value based at least in part on an observed rate value and to produce a compensating value, and

10 wherein said inertia compensation value is based at least in part on said compensating value.

58. The apparatus according to claim 57, wherein said combiner comprises an adder, and

15 wherein said adder produces said compensating value as a difference of the value based at least in part on said observed rate value and the value based at least in part on said rate target value.

59. The apparatus according to claim 57, wherein said inertia compensation value producer further comprises a stabilizer configured and arranged to receive said compensating  
20 value and to produce said inertia compensation value.

60. The apparatus according to claim 57, wherein said stabilizer comprises a proportional-integral controller.

61. The apparatus according to claim 60, wherein an operation of said stabilizer is characterized by a proportional  
25 gain and an integral gain, and

wherein at least one among said proportional gain and said integral gain varies in response to at least a magnitude of said compensating value.

62. The apparatus according to claim 35, wherein at least one among said power demand value and said modified power demand value is expressible as a velocity.

63. The apparatus according to claim 35, wherein at least  
5 one among said power demand value and said modified power demand value is expressible as an angular velocity.

64. The apparatus according to claim 35, wherein said apparatus further comprises a second lookup table configured and arranged to map said power supply requirement value to said  
10 power demand value,

wherein said mapping varies at least in part according to a temperature.

65. The apparatus according to claim 35, wherein said apparatus further comprises a second lookup table configured  
15 and arranged to map said power supply requirement value to said power demand value,

wherein said mapping varies at least in part according to a density.

66. An apparatus comprising:

20 a lookup table configured and arranged to receive a power supply requirement value and to produce a rate target value; and

an adder configured and arranged to receive a power demand value and to produce a modified power demand value,

25 wherein said power demand value is based at least in part on said power supply requirement value, and

wherein said modified power demand value is based at least in part on a sum of a value based at least in part on said power demand value and a value based at least in part on an inertia compensation value, and

5                    wherein said inertia compensation value is based at least in part on said rate target value.

67.                The apparatus according to claim 66, said apparatus further comprising a stabilizer configured and arranged to receive a compensating value and to produce said inertia  
10 compensation value,

                  wherein said compensating value is based at least in part on said rate target value.

68.                A system comprising:  
  
                  a power source configured and arranged to supply  
15 power;

                  a load configured and arranged to consume power;

                  a power converter configured and arranged to receive power from said power source and to supply power to said load;

                  an inertia compensation value producer configured and  
20 arranged to receive a power supply requirement value and to produce an inertia compensation value; and

                  a power demand value modifier configured and arranged to receive a power demand value and said inertia compensation value and to produce a modified power demand value,

25                    wherein said power supply requirement value is expressible in watts, and

wherein said power supply requirement value is based at least in part on a quantity of power consumed by said load, and

wherein said power demand value is based at least in part on said power supply requirement value, and

wherein said inertia compensation value is based at least in part on said power supply requirement value, and

wherein an operation of said power source is based at least in part on said modified power demand value, and

wherein said power demand value modifier produces said modified power demand value at least in part by adding a value based at least in part on said inertia compensation value to a value based at least in part on said power demand value.

69. The system according to claim 68, wherein said load consumes electrical power.

70. The system according to claim 69, wherein said load comprises at least one motor.

71. The system according to claim 69, wherein said power converter comprises at least one generator.

72. The system according to claim 69, wherein said power converter further comprises at least one gearbox configured and arranged to couple said power source to said at least one generator.

73. The system according to claim 68, said system further comprising a demand sensor configured and arranged to produce an observed power consumption value,

wherein said observed power consumption value is based at least in part on a quantity of power consumed by said load, and

wherein said power supply requirement value is based  
5 at least in part on said observed power consumption value.

74. The system according to claim 73, said system further comprising a value converter configured and arranged to receive said observed power consumption value,

wherein said value converter is further configured  
10 and arranged to apply an efficiency reciprocal function to said observed power consumption value to produce said power supply requirement value, and

wherein said efficiency reciprocal function relates  
at least in part to an efficiency of power conversion by said  
15 power converter.

75. The system according to claim 68, said system further comprising a fuel supply controller configured and arranged to control a supply of fuel to said power source,

wherein said fuel supply controller is further  
20 configured and arranged to control said supply of fuel according to at least said modified power demand value.

76. The system according to claim 68, wherein said  
inertia compensation value producer is further configured and  
25 arranged to receive an observed rate value,

wherein said observed rate value is based at least in part on a rate of an output of said power source, and

wherein said inertia compensation value is based at least in part on said observed rate value.

77. The system according to claim 76, wherein said rate of an output of said power source is expressible as a velocity.

5 78. The system according to claim 77, wherein said power source is a turbine having an output shaft, and

wherein said rate of an output of said power source comprises a rotational speed of said output shaft, and

10 wherein said power converter receives power from said power source at least in part through said output shaft.

79. The system according to claim 78, wherein said turbine has a compressor, and

wherein a rotational speed of said compressor is based at least in part on said modified power demand value.

15 80. The system according to claim 68, wherein said load is configured and arranged to propel a vehicle.

81. The system according to claim 68, wherein said load is configured and arranged to propel a locomotive.

20 82. The system according to claim 79, wherein said inertia compensation value producer comprises a lookup table configured and arranged to map said power supply requirement value to a rate target value, and

wherein said inertia compensation value is based at least in part on said rate target value, and

25 wherein said turbine receives air to support combustion, and

wherein said mapping varies at least in part according to a temperature of said air.

83. The system according to claim 79, wherein said inertia compensation value producer comprises a lookup table  
5 configured and arranged to map said power supply requirement value to a rate target value, and

wherein said turbine receives air to support combustion, and

wherein said mapping varies at least in part  
10 according to a density of said air.

84. An apparatus comprising:

a first lookup table configured and arranged to receive a power supply requirement value and to produce a power supply rate target value;

15 a first adder configured and arranged to subtract an observed rate value from said rate target value to produce a rate error value;

a stabilizer configured and arranged to receive the rate error value and to output an inertia compensation value;

20 a second lookup table configured and arranged to receive the power supply requirement value and to produce a power demand value; and

a second adder configured and arranged to receive the inertia compensation value and the power demand value and to  
25 produce a modified power demand value.

85. A system comprising:

a power source configured and arranged to produce a first power output;

an energy converter configured and arranged to receive the first power output and to produce a converted power output to drive a load;

a demand sensor configured and arranged to output an observed power consumption value, said observed power consumption value being related to a level of power demanded by the load;

10 a value converter configured and arranged to receive the observed power consumption value and to output a power supply requirement value;

a first lookup table configured and arranged to receive the power supply requirement value and to produce a rate target value;

15 a rate sensor configured and arranged to output an observed rate value, said observed rate value being related to a rate of said first power output;

a first adder configured and arranged to subtract said observed rate value from said rate target value to produce a rate error value;

a stabilizer configured and arranged to receive the rate error value and to output an inertia compensation value;

25 a second lookup table configured and arranged to receive the power supply requirement value and to produce a power demand value;

a second adder configured and arranged to receive the inertia compensation value and the power demand value and to produce a modified power demand value; and

5 a fuel supply controller configured and arranged to receive the modified power demand value and to control the supply of fuel to said power source according to said modified power demand value.

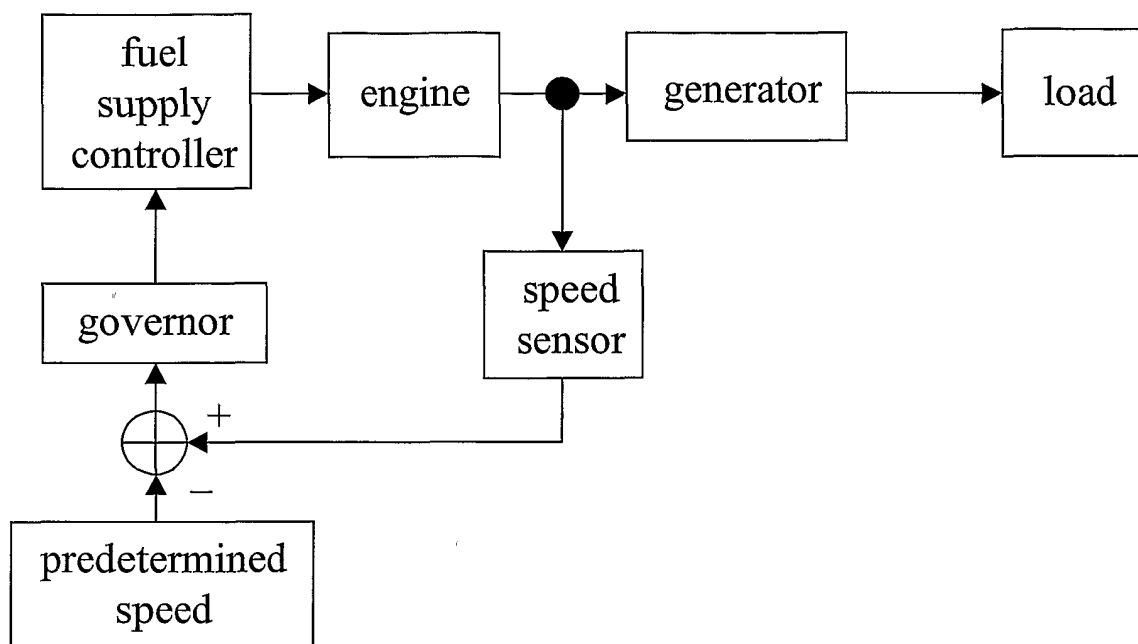

FIG. 1 (RELATED ART)

2/12

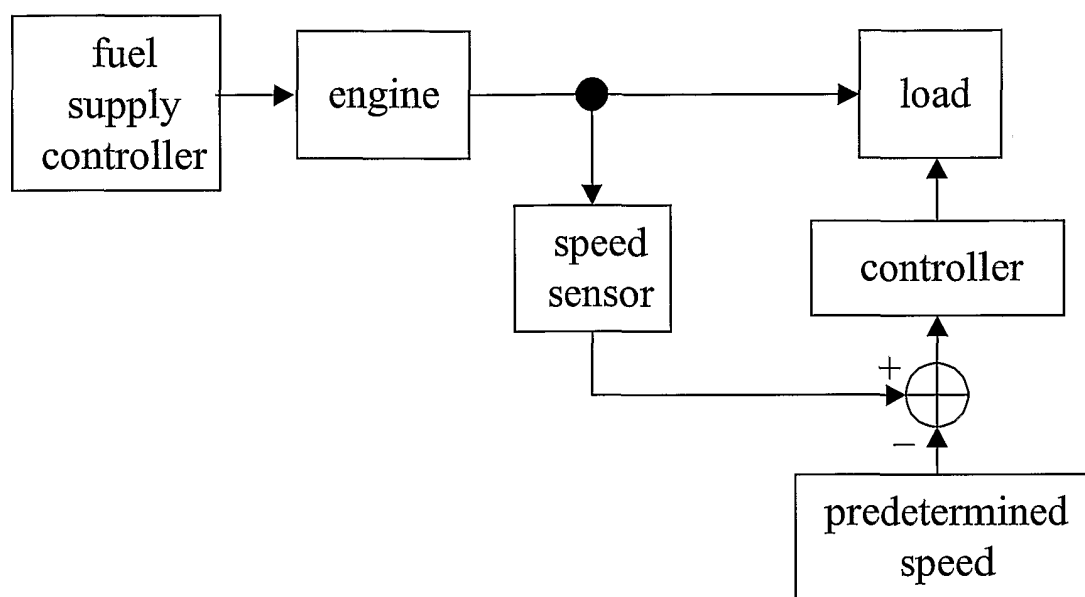

FIG. 2 (RELATED ART)

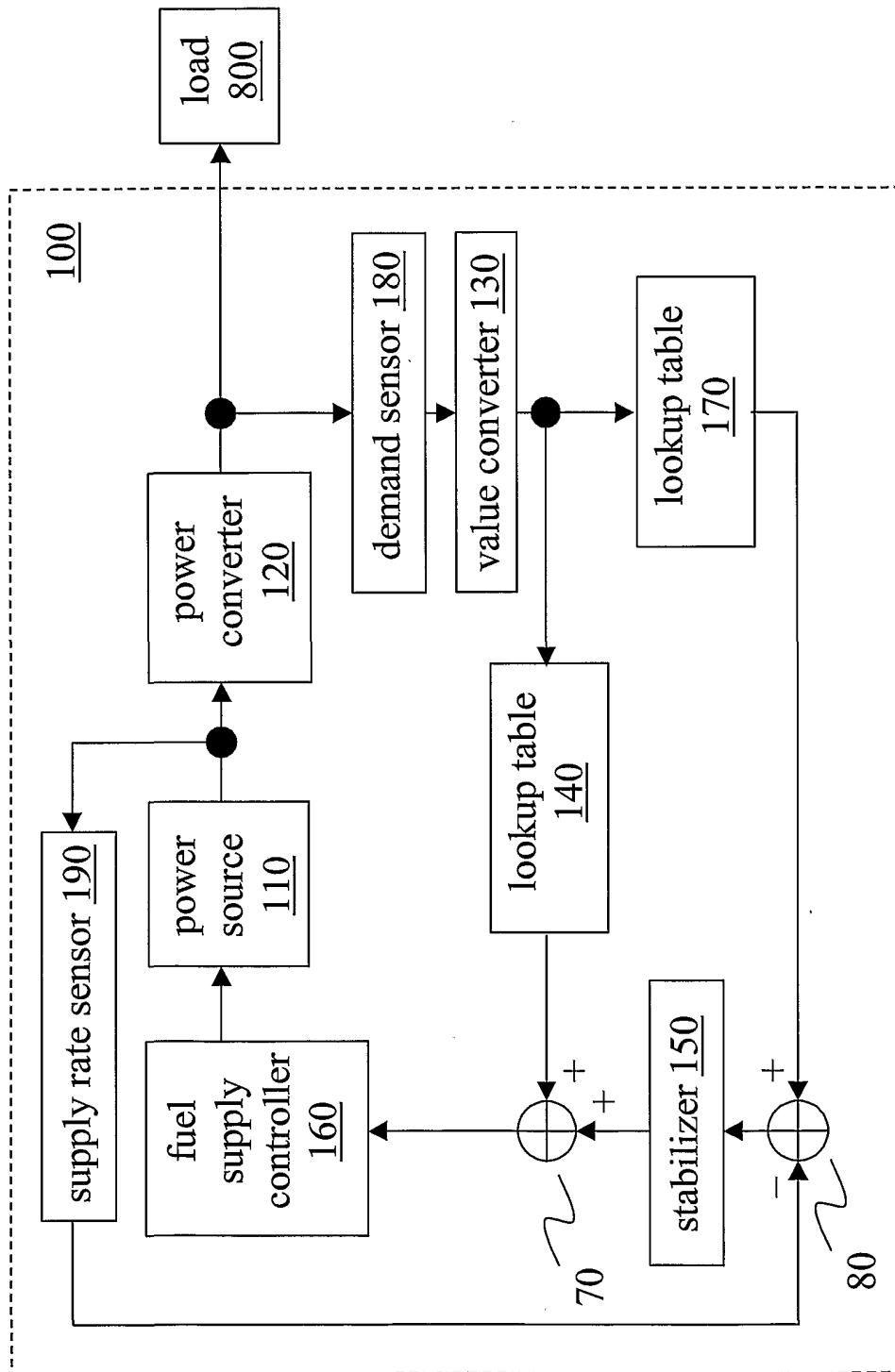

FIG. 3

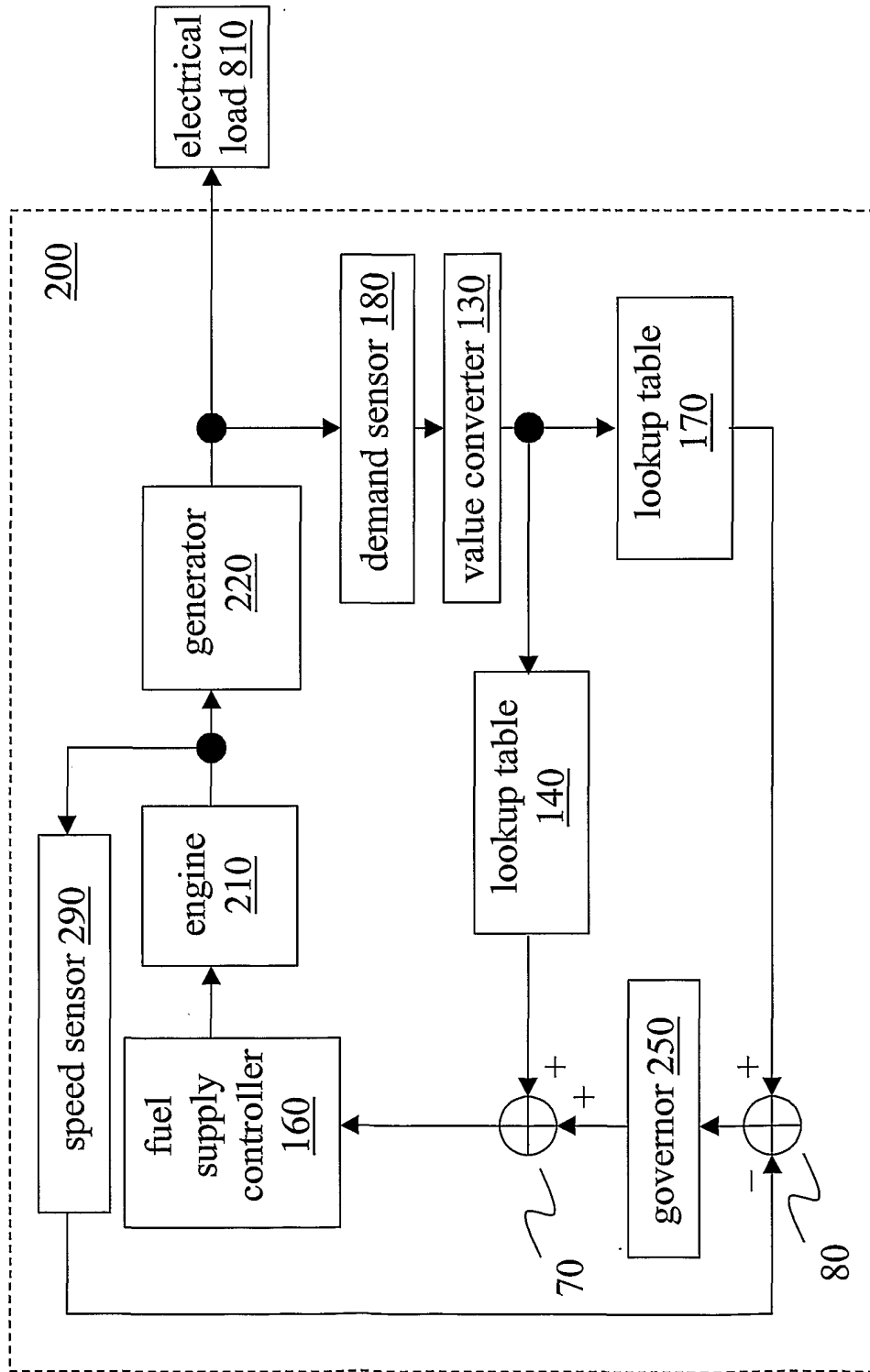

FIG. 4

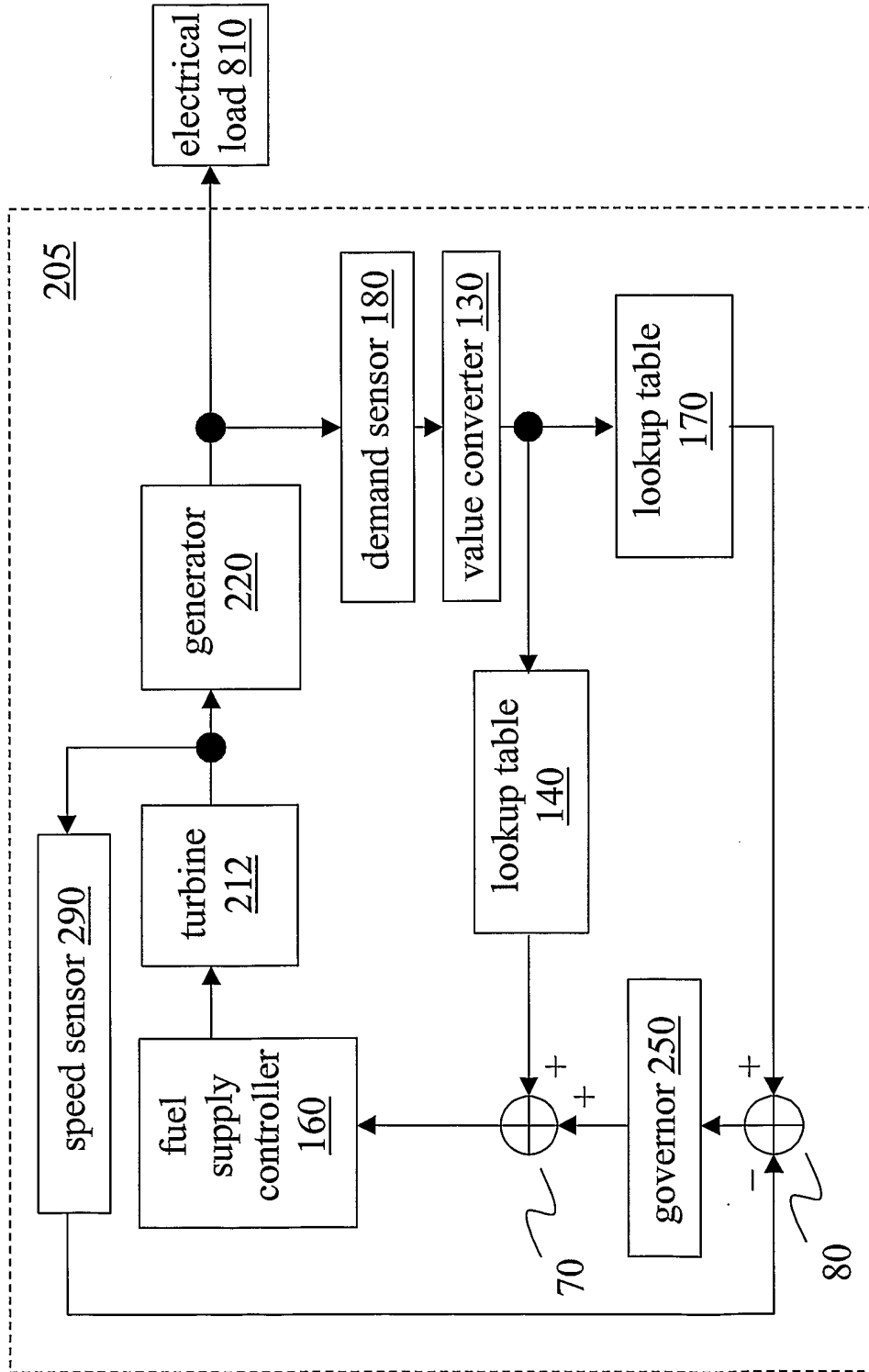

FIG. 5

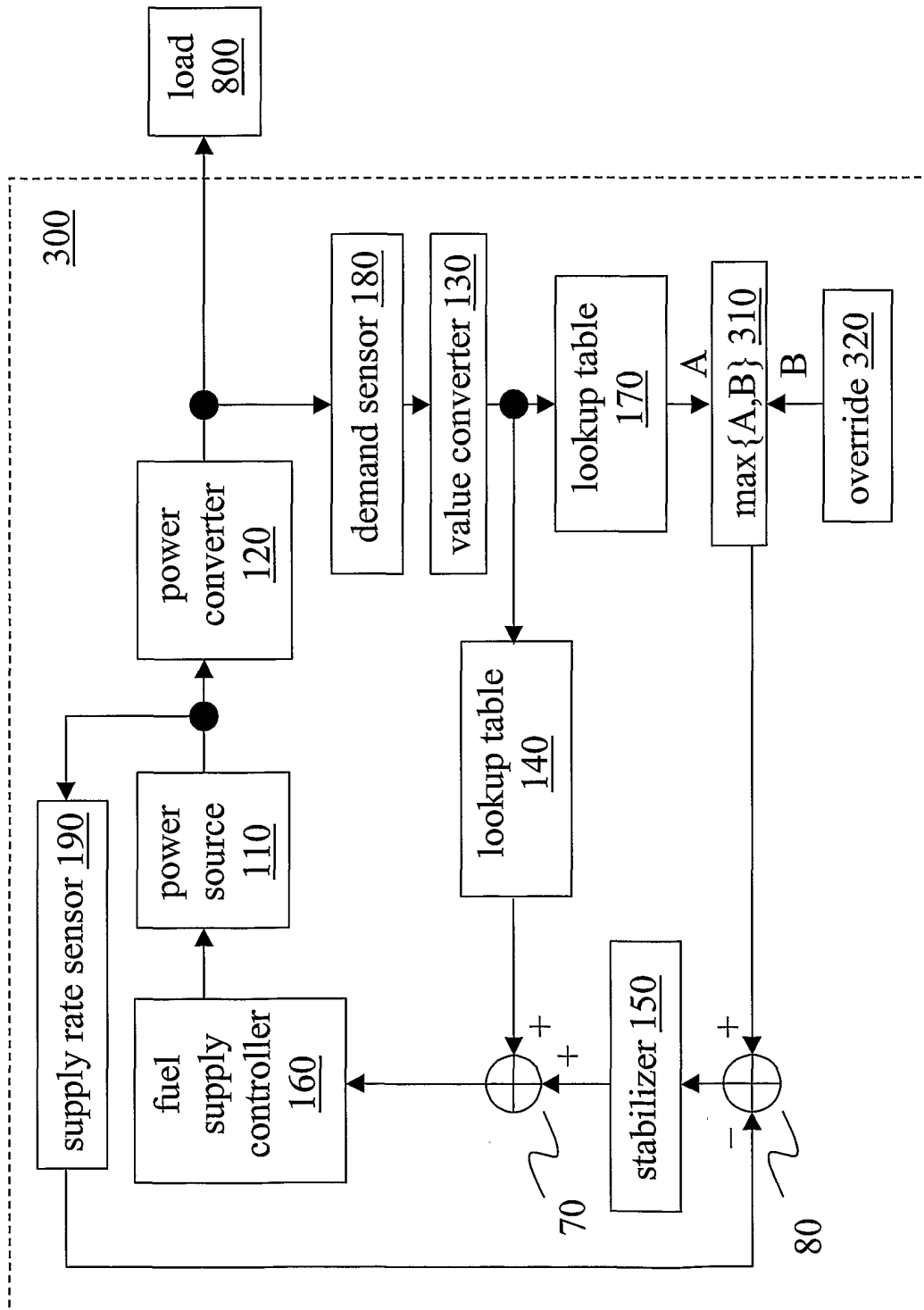

FIG. 6

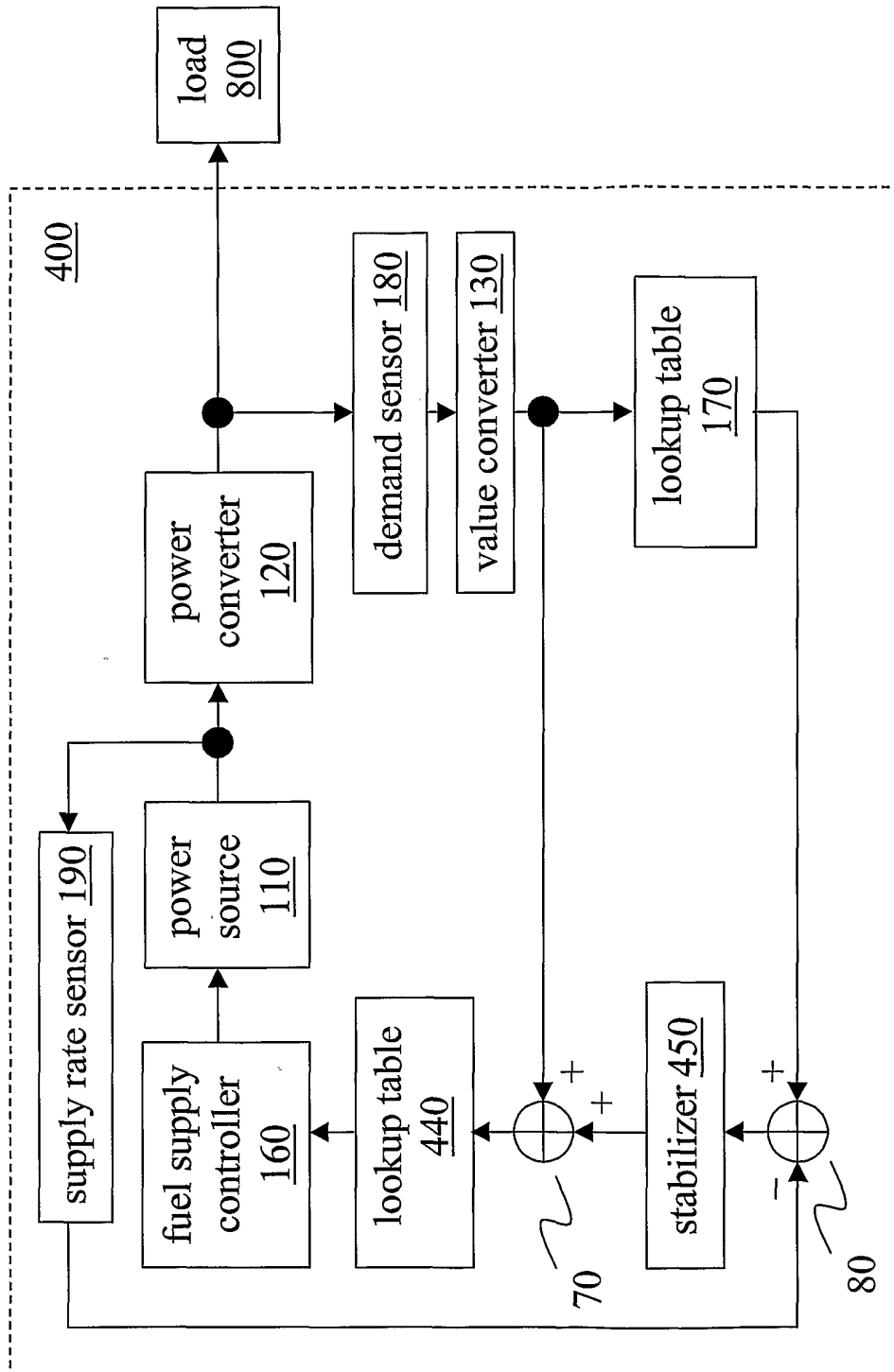

FIG. 7

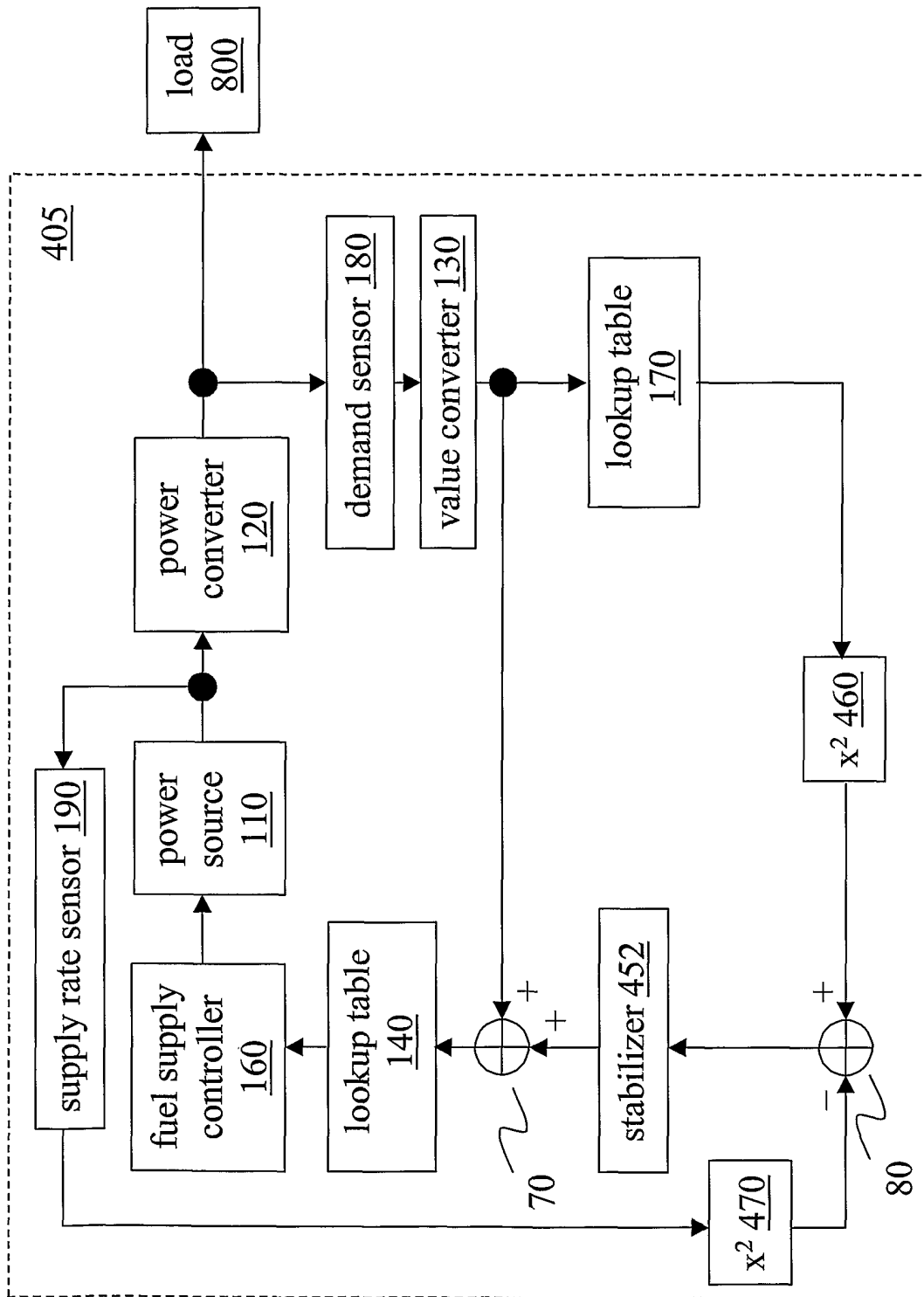

FIG. 8

9/12

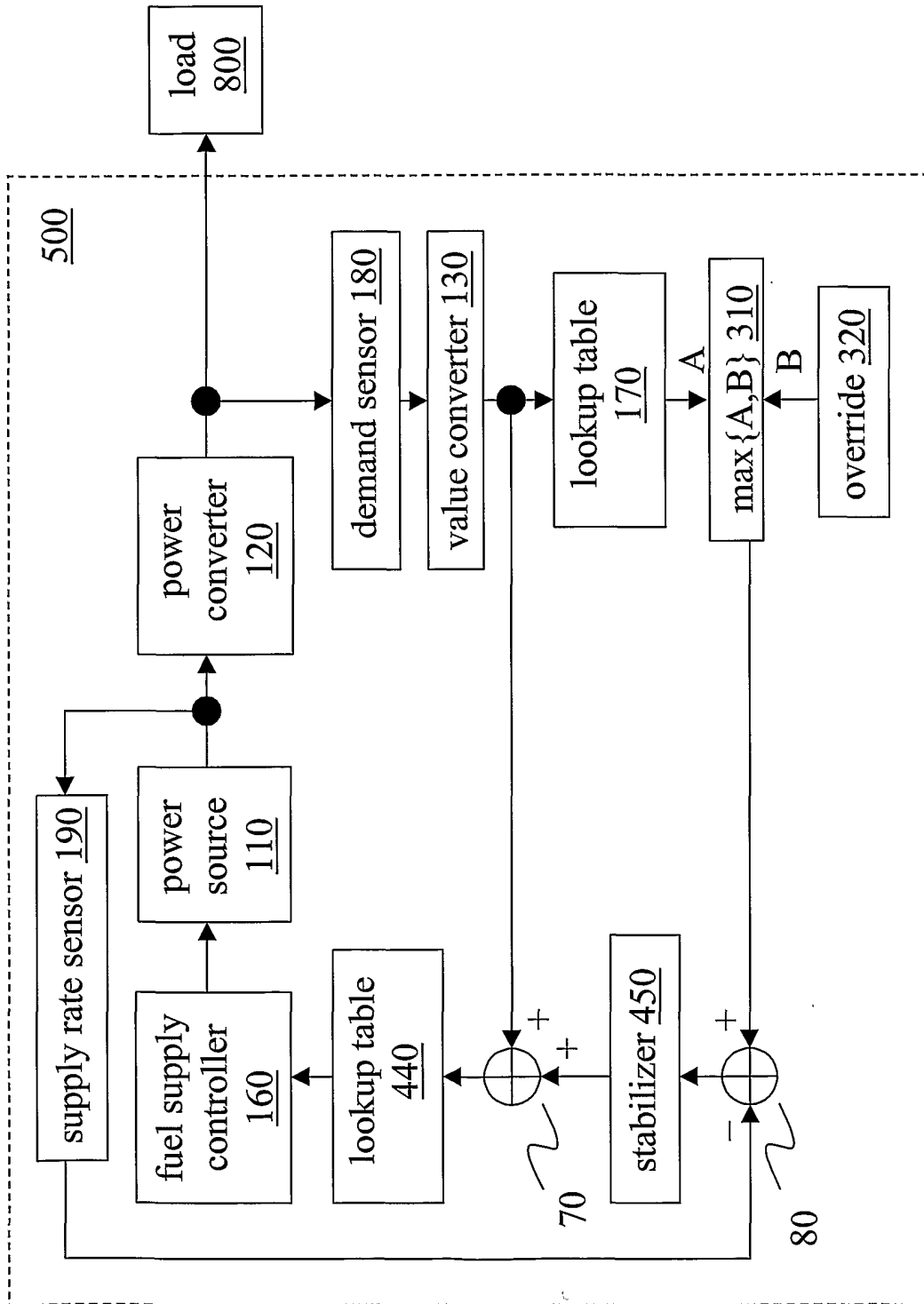

FIG. 9

10/12

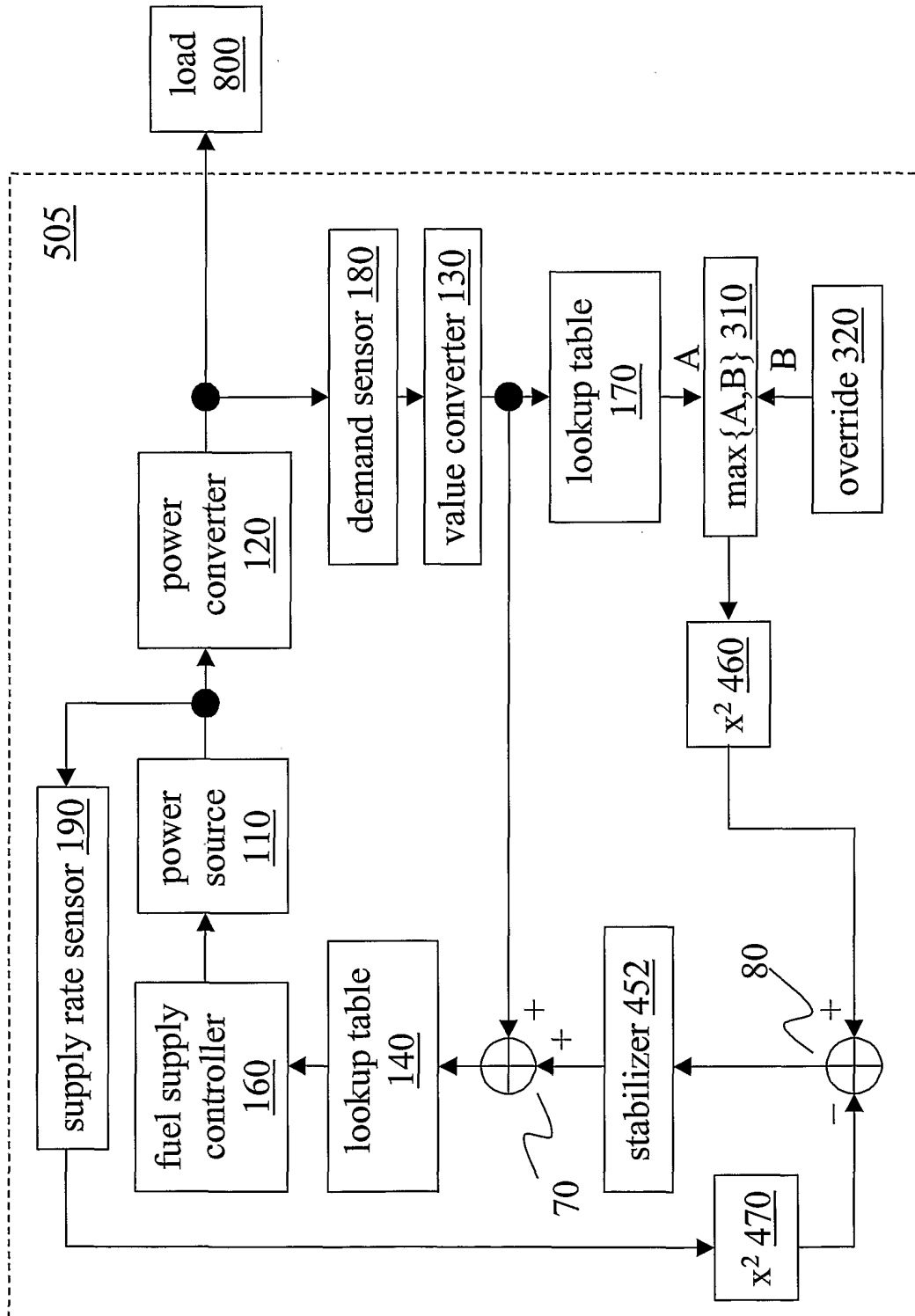

FIG. 10

FIG. 11

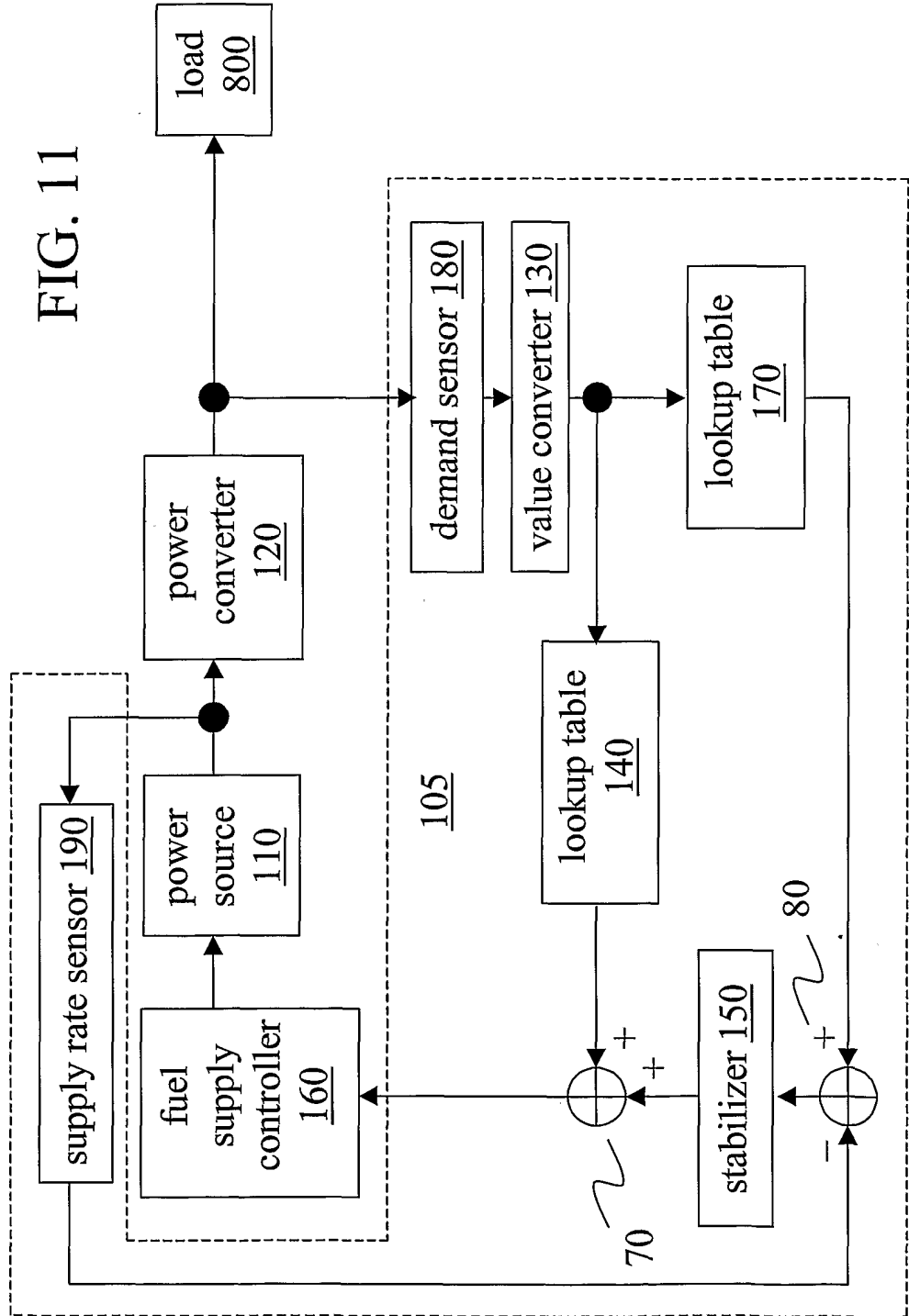

FIG. 12

