

J. L. SIMMS & W. T. DUVALL, Improvement in Towing Canal Boats.

No. 130,080.

Patented July 30, 1872.

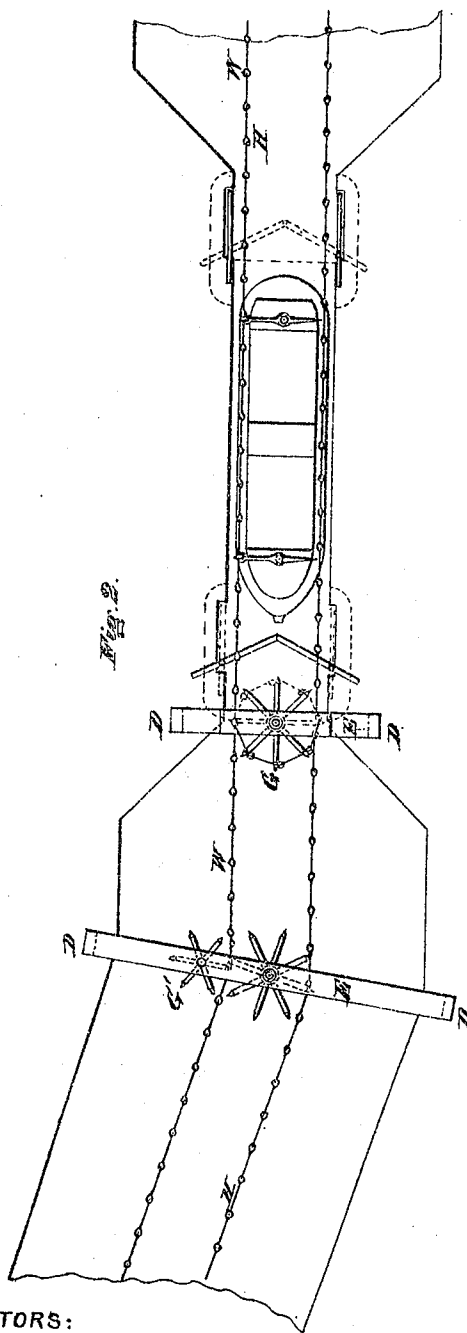
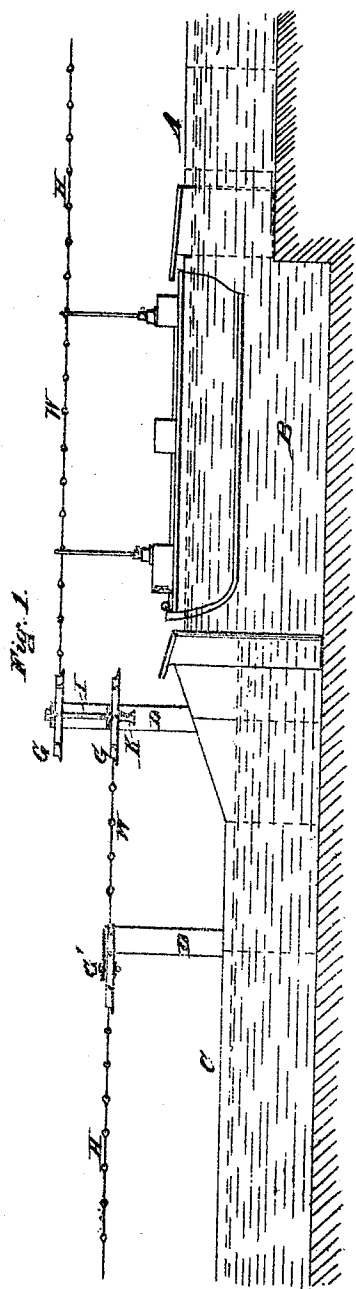

WITNESSES:

J. M. Smith,
J. Robbins

INVENTORS:

J. L. Simms and W. T. Duvall
by Attorneys
Brown, Coombs & Co.

J. L. SIMMS & W. T. DUVALL. 3 Sheets--Sheet 2.

Improvement in Towing Canal Boats.

No. 130,080.

Patented July 30, 1872.

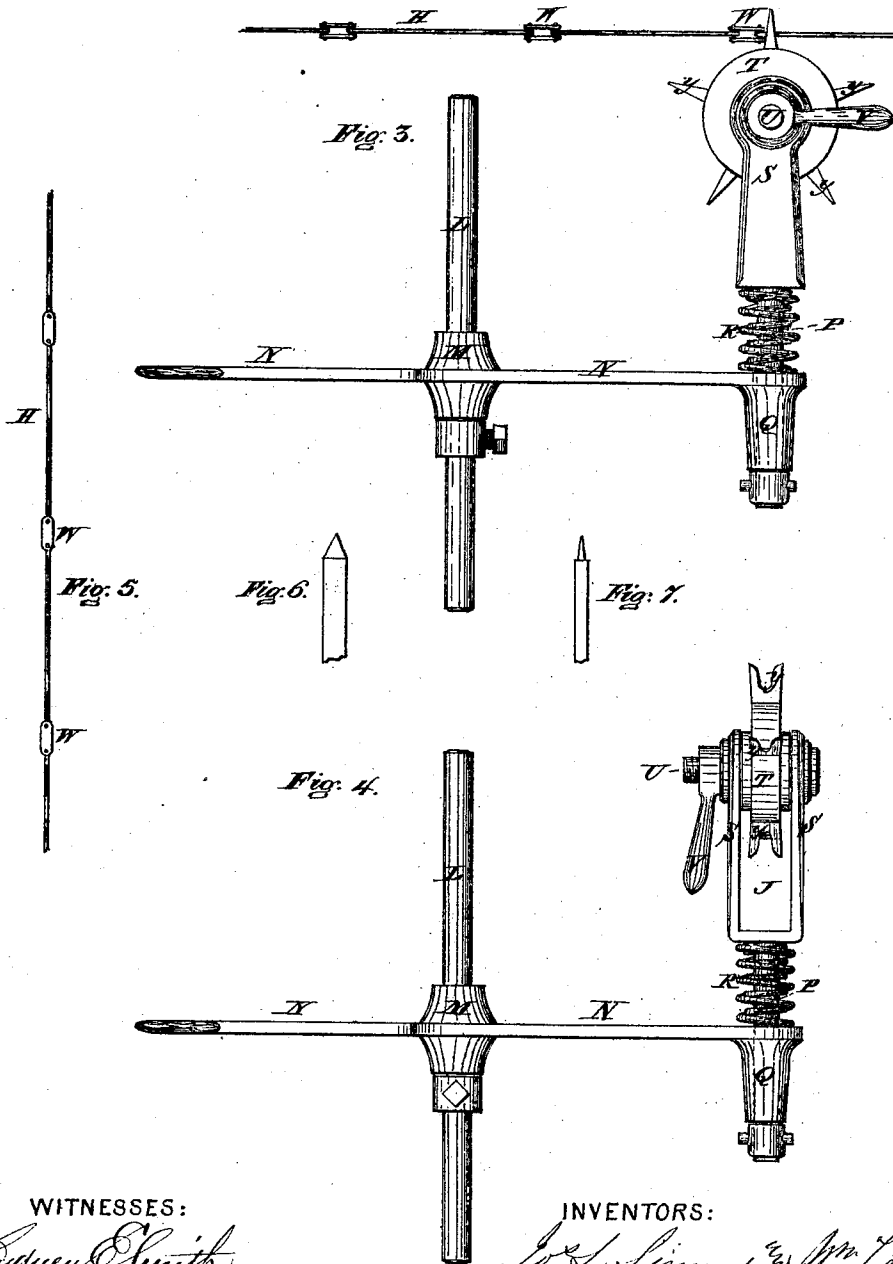

WITNESSES:

Jedney C. Smith,
J. C. Robbins

INVENTORS:

J. L. Simms & W. T. Duvall
by Attorneys
Brown, Coomb & Co.

J. L. SIMMS & W. T. DUVALL.
Improvement in Towing Canal Boats.

No. 130,080.

Patented July 30, 1872.

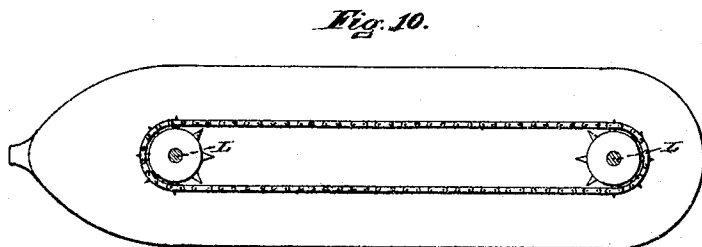
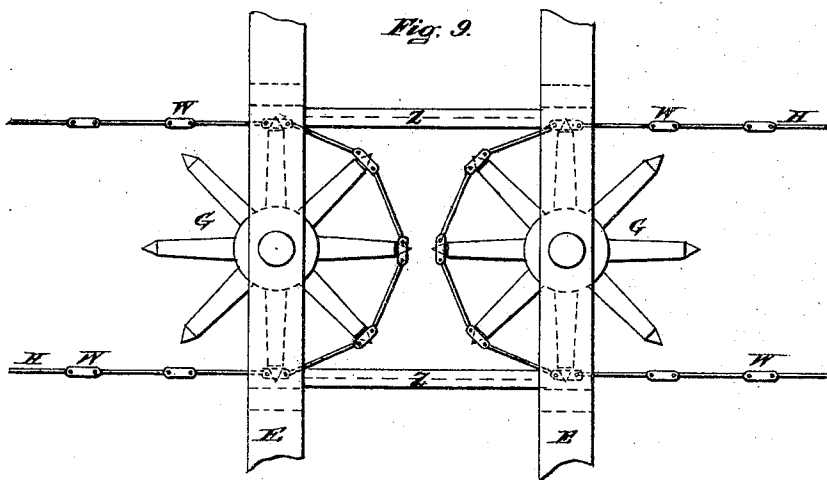
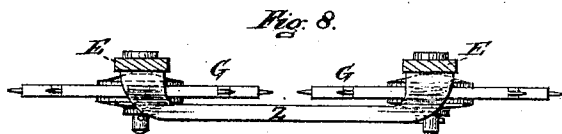

WITNESSES:

Judney C. Smith,
J. C. Robbins

INVENTORS:

J. L. Simms and W. T. Duvall
by Attorneys
Brown, Coombs & Co.

UNITED STATES PATENT OFFICE.

JOSEPH L. SIMMS AND WILLIAM T. DUVALL, OF GEORGETOWN, D. C.

IMPROVEMENT IN TOWING CANAL-BOATS.

Specification forming part of Letters Patent No. 130,080, dated July 30, 1872.

To all whom it may concern:

The following is a specification of a new and Improved Method of Propelling Boats on Canals, invented by JOSEPH L. SIMMS and WILLIAM T. DUVALL, both of the city of Georgetown, in the county of Washington and District of Columbia.

This invention is designed to dispense with animal-power in the traction of boats on canals by the substitution of a positive mechanical traction, whereby the expense of keeping a tow-path in repair is saved, and the space at present occupied by mules and provender in the boat may be utilized for cargo, and the boat be worked with a much less number of hands than are necessary under the present system. The rudder may also be dispensed with, so that the boat may be made from four to six feet longer, thus giving space and buoyancy to carry from ten to thirty tons more cargo. The traction-power is obtained through a horizontal arrangement of endless chains overhead and in sections, said sections being geared together, so that power applied to operate one section is transmitted to each adjacent section, and through them to the next for any distance that such local agency is equivalent to or capable of operating, as in Letters Patent No. 125,224, granted to us April 2, 1872. For this purpose we propose to utilize the overflow from the waste-wears at the locks, and from the canal itself; also, from lateral tributaries, which frequently occur on most canals, by applying it to any suitable water-wheel, such as turbine, overshot, or current wheels, as may be best adapted to the locality. This invention consists in various novel mechanical devices for connecting the boat with the traction-chain, whereby the hold on the latter is gradually taken as the *vis inertiae* is overcome; furthermore, in such application of the clamping device to the boat as to render it operative for steering, to bring it into and out of the locks, or to throw it outside of its course to avoid any apprehended collision. It also consists in various details of construction, which will be particularly described hereinafter.

We will now proceed to describe more particularly by referring to the drawing, in which—

Figure 1 represents a central longitudinal

section of a canal, showing a lock with boat therein on the upper level, and having our invention applied. Fig. 2 is a plan or top view of the same. Fig. 3 is a side view, on an enlarged scale, of the grappling device by which the boat is drawn and steered, and in position when drawing in line of the longitudinal center of the boat, showing also a section of the endless chain in side elevation. Fig. 4 is a similar view of the same with the grappling-wheel in the position occupied when the boat is passing through a lock. Fig. 5 is a top view of a section of chain. Figs. 6 and 7 are side and edge views of the spur portion of the carrying-wheel formed to engage with the links of the traction-chain. Fig. 8 is a side elevation on an enlarged scale, showing the device for disconnecting the grappling device from one section of the endless chain, and passing it forward in line to connect with the next section. Fig. 9 is a plan or top view of the same. Fig. 10 is a plan or top view of a boat, showing the bow and stern grappling devices geared together by an endless chain, so that they may be operated simultaneously.

Referring to the drawing, A represents the high level of a canal; B, the lock; and C, the lower level. In illustrating this invention we have selected this portion of a canal so as to show the mode of passing a lock, as well as the plan of direct propulsion; and in Fig. 2 we have shown the arrangement used for turning curves in the canal. We first erect standards D of cast-iron, wood, or other suitable materials, on each side of the canal, which are connected at their top by a bridge-piece or beam, E, across the canal to form bearings for the necessary driving and carrying wheels G G', which are arranged at suitable distances apart to sustain the endless sections of chain H in as nearly as possible a horizontal position. On straight portions of the canal the intermediate supports may consist of a single pillar planted in the center of the canal, and provided with a T or cross head to support the carrying-wheels. At the outlet or fall of a lock two sections of the endless chain invariably terminate, and are supported by two carrying-wheels, G, arranged one above the other on the same vertical shaft I, at a distance apart equal to the fall of water from the

upper to the lower level, and, when in, the brakes J of the grappling-wheels are loosened to allow the latter to revolve freely until the water in the lock lowers sufficiently to free them from the chain. On the lower end of the shaft I is arranged a capstan, K, around which a turn of the boat's painter is taken, when the level in the lock is reduced to that of the lower section of the canal, by which the *vis inertiae* is overcome, and the boat passes out of the lock and grapples the next section of chain, the reverse action taking place with an ascending boat.

The power necessary to keep these endless chains in motion is obtained from the overflow of the waste-water on the side of the lock, being applied to any suitable water-wheel connected, by shafts and gearing, with the vertical shaft I; and in long levels, where it is necessary to divide up the chain into two or more sections, the carrying-wheels at the termini of each section may be geared together, and, if necessary, any waste-water or side current may be made available to operate said wheels, through another water-wheel, by gearing, as in the first-named instance. Thus water-power may be applied at any required distance apart over the entire route, and the sections may be all geared together, or they may be in pairs, each pair being operated by a distinct water-power, and in case sufficient waste or tributary water is not accessible stationary steam-power may be used to operate the chain-wheels. The grappling device consists of a vertical spindle, L, seated in a suitable socket or bearings in the center of the breadth of the boat, and, by preference, one at or near each end. To this spindle is attached, by spline-gear or its equivalent, a collar, M, to which latter is connected a horizontal lever, forming two arms, N, each of which is about equal in length to half the beam-measurement of the boat; and at the extremity of one of the arms N is the grappling device for making connection with the endless chain overhead. This device consists of a spindle, P, capable of rotation in a socket, Q, and supported by a helical spring, R. The upper portion of this grappling device consists of a clamp forming two jaws, S, between which is supported a sprocket-wheel, T, by a clamping-screw, U, passing through both, so that by tightening the wing-nut V on said screw the wheel T is held fast, and by unscrewing it the latter is allowed to revolve. The forked spurs of said wheel are so shaped as to receive the round portion of the chain between the prongs, and when clamped, to prevent its rotation, will engage with the connecting-links W, or eyes, as the case may be, by which means, when the chains H are put in motion, the boat will be propelled. In ordinary travel the arms N will range about parallel with the keel of the boat; but, in order to bring the latter into the

lock, they will be arranged transversely or athwart ships, the up and down lines of the propelling-chains being nearly over each side of the lock; and, if need be, to avoid collision with another boat, they may be turned to the side to throw the boat half her width toward the right-hand shore, thus rendering it impossible for a boat running in the opposite direction to collide with her. The spindles L at the bow and stern of the boat may be provided with chain-wheels and geared together by an endless chain so as to be operated simultaneously. The grappling device is also made vertically adjustable on the spindle L, to elevate or lower it according to the depth to which the boat is loaded. At the junction of two sections of the endless traction-chains is arranged a leader, Z, which extends from the end of the straight portion of one chain to the adjacent end of such portion of the next section, as represented in Fig. 8. This leader Z is of somewhat V form, so that the forks y of the grappling-wheel T will span and slide along it from one section to the next, and being inclined slightly downward at each end acts upon the grappling-wheel to depress it on the spring R, and thus disengage it from the chain and lead it in a direct line to engage with the next section, to the level of which it is again borne up by the said spring after passing the leader Z. This action occurs first on the bow grapples and afterward on that at the stern, the distance apart of which is such that before the latter is released from one section the former is engaged with the next section, so that the traction is continuous.

In positions where the sections of the endless chains H are unusually long, or where curves in the canal occur, supporting-wheels G' are located at intervals. On straight sections of the route the axles of the supporting-wheels, which are arranged in pairs, are both between the up and down sides of the chain, and are so hung as to incline slightly downward at their outer or shore sides, so as to pick up the drooping or sagging chain in its passage; but in cases where bends occur these wheels are arranged both on the inside of the bend of both up and down lines of chain section, as represented in Fig. 2.

The advantages of this horizontal up-and-down arrangement and means of traction are that all lateral or angular tow-lines are dispensed with, and the traction is applied in the direct line in which it is desired to move the boat. No rudder is required, and consequently no deflection of the water is caused either from the bow or stern of the boat.

Claims.

1. In combination with an endless traction-chain, we claim the grappling device T, substantially as herein shown and described, and the leader Z, whereby said grappling de-

vice is caused to be automatically detached from one section of traction-chain and connected with the next, as herein specified.

2. In combination with an endless traction-chain, a grappling apparatus, substantially as herein described, so connected with the boat as to steer the latter, as desired, by swinging it about a spindle located centrally,

or nearly so, of the beam-measurement of said boat.

JOS. L. SIMMS.
WM. T. DUVALL.

Witnesses:

SYDNEY E. SMITH,
W. MORRIS SMITH.