

(19) World Intellectual Property
Organization
International Bureau



(43) International Publication Date
10 November 2005 (10.11.2005)

PCT

(10) International Publication Number
WO 2005/106358 A2

- (51) International Patent Classification⁷: **F25D 17/06**, 29/00
- (21) International Application Number: PCT/BR2005/000066
- (22) International Filing Date: 29 April 2005 (29.04.2005)
- (25) Filing Language: English
- (26) Publication Language: English
- (30) Priority Data: PI 0402013-8 4 May 2004 (04.05.2004) BR
- (71) Applicant (for all designated States except US): **MULTI-BRÁS S.A. ELETRODOMÉSTICOS** [BR/BR]; Avenida das Nações Unidas, 12.995 - 32º andar, 04578-000 São Paulo - SP (BR).
- (72) Inventors; and
- (75) Inventors/Applicants (for US only): **PIMENTEL, Fábio Ribeiro** [BR/BR]; Rua Itaiópolis, 177 ap. 703, 89204-100 Joinville - SC (BR). **MEZAVILA, Moacyr, Marangone** [BR/BR]; Rua XV de Novembro, 1245 - ap. 903, 89201-602 Joinville - SC (BR). **SCHMID, Alexandre Cury** [BR/BR]; Rua Almirante Tamandaré, 157 ap. 102, 89204-140 Joinville - SC (BR). **RODRIGUES JÚNIOR, Rogério** [BR/BR]; Rua Bento Gonçalves, 225 ap. 702, 89216-110 Joinville - SC (BR). **RÜCKER, Alexandre Pinto Rebello** [BR/BR]; Rua Dona Francisca, 1883 - ap. 302 - Bl. A, 89221-007 Joinville - SC (BR). **MARQUES, Marco, Eduardo** [BR/BR]; Rua Orestes Guimarães, 421 - ap. 501, 89204-060 Joinville - SC (BR).
- (74) Agents: **ARNAUD, Antonio M.P.** et al.; Rua José Bonifácio, 93 - 9th floor, 01003-901 São Paulo - SP (BR).
- (81) Designated States (unless otherwise indicated, for every kind of national protection available): AE, AG, AL, AM, AT, AU, AZ, BA, BB, BG, BR, BW, BY, BZ, CA, CH, CN,

[Continued on next page]

(54) Title: REFRIGERATION CONTROL SYSTEM IN COMBINED REFRIGERATION APPLIANCES

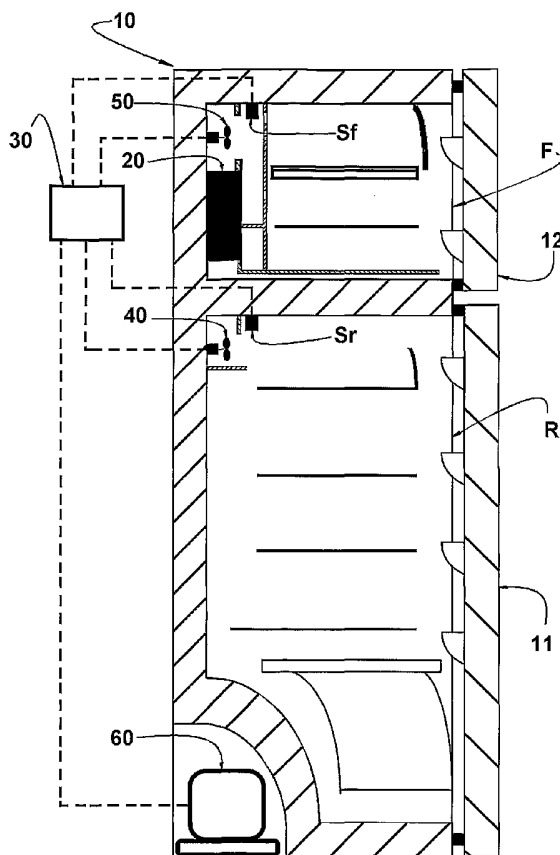

(57) Abstract: A refrigeration control system in combined refrigeration appliances of the type comprising: a refrigerating compartment (R); a freezing compartment (F); a compressor (60); an evaporator (20); a refrigerating compartment fan (40) and a freezing compartment fan (50); and a control means (30) to activate and deactivate the compressor (60) and both the refrigerating compartment fan (40) and the freezing compartment (50) fan as a function of the activation and deactivation temperatures (T_{ar} , T_{af} , T_{dr} , T_{df}) detected by the refrigerating compartment temperature sensor (S_r) and the freezing compartment temperature sensor (S_f). The control means (30) is operatively associated with the refrigerating compartment fan (40) to selectively and periodically adjust the speed of the latter, so that the temperature of the refrigerating compartment (R) reaches a deactivation value of the refrigerating compartment fan (40) at the same time in which the temperature of the freezing compartment (F) reaches a deactivation value of both the freezing compartment fan (50) and the compressor (60).

WO 2005/106358 A2



CO, CR, CU, CZ, DE, DK, DM, DZ, EC, EE, EG, ES, FI, GB, GD, GE, GH, GM, HR, HU, ID, IL, IN, IS, JP, KE, KG, KM, KP, KR, KZ, LC, LK, LR, LS, LT, LU, LV, MA, MD, MG, MK, MN, MW, MX, MZ, NA, NI, NO, NZ, OM, PG, PH, PL, PT, RO, RU, SC, SD, SE, SG, SK, SL, SM, SY, TJ, TM, TN, TR, TT, TZ, UA, UG, US, UZ, VC, VN, YU, ZA, ZM, ZW.

(84) Designated States (*unless otherwise indicated, for every kind of regional protection available*): ARIPO (BW, GH, GM, KE, LS, MW, MZ, NA, SD, SL, SZ, TZ, UG, ZM, ZW), Eurasian (AM, AZ, BY, KG, KZ, MD, RU, TJ, TM),

European (AT, BE, BG, CH, CY, CZ, DE, DK, EE, ES, FI, FR, GB, GR, HU, IE, IS, IT, LT, LU, MC, NL, PL, PT, RO, SE, SI, SK, TR), OAPI (BF, BJ, CF, CG, CI, CM, GA, GN, GQ, GW, ML, MR, NE, SN, TD, TG).

Published:

— *without international search report and to be republished upon receipt of that report*

For two-letter codes and other abbreviations, refer to the "Guidance Notes on Codes and Abbreviations" appearing at the beginning of each regular issue of the PCT Gazette.

REFRIGERATION CONTROL SYSTEM IN COMBINED REFRIGERATION
APPLIANCES

Field of the Invention

The present invention refers to a refrigeration
5 control system to be applied to combined refrigeration
appliances that present a refrigerating compartment
and a freezing compartment, each provided with a
forced air flow which is refrigerated in an evaporator
and blown by a respective fan.

10 Prior Art

There are well known in the art the combined
refrigeration appliances in which each of the
refrigerating and freezing compartments is provided
with a temperature sensor operatively associated with
15 an electronic control module or means which is
designed to command the activation of the fans of said
compartments and of the compressor of the
refrigeration circuit of the refrigeration appliance.
In said combined appliances, the refrigerating
20 compartment temperature sensor informs the control
means about the activation and deactivation
temperatures of the refrigerating compartment fan, in
order to vary the cool air supply to the compartment
as a function of the temperature detected by the
25 refrigerating compartment temperature sensor. On the
other hand, the freezing compartment temperature
sensor informs the control means about the activation
and deactivation temperatures of the freezing
compartment fan and of the compressor. Such
30 refrigeration control system allows the refrigerating
compartment fan to operate independently of the
freezing compartment fan, according to the temperature
signals that the refrigerating compartment temperature
sensor sends to the control means.
35 Depending on how often the refrigerating compartment

is used, loss of synchrony in the operation of both fans can usually occur, since the refrigerating compartment fan can be activated by the control means as a function of the temperature condition detected by the refrigerating compartment temperature sensor, even with both the compressor and the freezing compartment fan being deactivated. In terms of operation of the refrigeration appliance, the operation mentioned above is not prejudicial, since the activation of the refrigerating compartment fan without activation of the compressor causes the latter to be reactivated more rapidly, promoting cooling of the refrigerating compartment.

Nevertheless, in terms of reduction of energy consumption, the above operation is not desired, since it causes irregular operating cycles of the compressor. To reduce energy consumption, the more adequate operation is the one according to which the compressor operates in regular cycles, with the activation and deactivation times being cyclically repeated.

Another aspect regarding the known refrigeration control systems is the fact that they do not allow the occurrence of a joint operation of the compressor and fans which is adequate to a special and temporary usage pattern of the refrigeration appliance as a whole or of the refrigerating compartment only. In the known appliances, the designed adjustment is limited to the setting of the operational temperature ranges of the refrigeration appliance.

Objects of the Invention

As a function of the inconveniences mentioned above, it is an object of the present invention to provide a refrigeration control system in combined refrigeration appliances of the type considered herein, which leads

to a synchronized operation of the fans of the refrigerating and freezing compartments, in order to minimize the occurrences of activation of the refrigerating compartment fan while the compressor fan is deactivated.

It is a further object of the present invention to provide a refrigeration control system as described above, which allows the user to set the operation of the compressor and of the fans to a special reduced and temporary usage pattern of the combined refrigeration appliance.

It is still a further object of the present invention to provide a refrigeration control system as described above, which allows the user to set the operation and the speed of the refrigerating compartment fan to a special intense and temporary usage pattern of the refrigerating compartment.

Summary of the Invention

Aiming at attaining the objects mentioned above, the present invention provides a refrigeration control system for combined refrigeration appliances of the type comprising: a refrigerating compartment provided with at least one refrigerating compartment temperature sensor; a freezing compartment provided with a freezing compartment temperature sensor; a compressor; an evaporator; a refrigerating compartment fan and a freezing compartment fan to produce respective forced air flows through the evaporator and through the refrigerating compartment and the freezing compartment, respectively; and a control means to activate and deactivate the compressor and the refrigerating compartment and freezing compartment fans as a function of the activation and deactivation temperatures detected by the refrigerating compartment temperature sensor and the freezing compartment

temperature sensor.

According to the invention, the control means is operatively associated with the refrigerating compartment fan to selectively and periodically adjust
5 the speed of the latter, so that the temperature of refrigerating compartment, detected by the refrigerating compartment temperature sensor, reaches deactivation value of the refrigerating compartment fan at the same time in which the temperature of the
10 freezing compartment, detected by the freezing compartment temperature sensor, reaches a deactivation value of both the freezing compartment fan and the compressor.

With the construction above, the control means
15 verifies, periodically, the cooling degree reached in both the refrigerating and freezing compartments, verifying whether the cooling speed of the refrigerating compartment is faster or slower than the cooling speed of the freezing compartment. Upon being
20 detected a certain difference in the cooling progress between both compartments, the refrigerating compartment fan has its speed raised or reduced so as to approximate the cooling degree of the refrigerating compartment to the cooling degree already reached in
25 the freezing compartment, aiming at obtaining the completion of both refrigeration operations at the same instant and to allow the simultaneous deactivation of both fans and of the compressor.

The increases and reductions of the speed of the
30 refrigerating compartment fan are preferably determined by a nominal speed percentage value of said fan, allowing the periodic verifications of the control means to lead to a progressive approximation of the two cooling degrees of the refrigerating
35 compartment and the freezing compartment.

The control means of the present invention further allows the user to instruct the refrigeration appliance to operate in a "vacation mode", according to which the operational temperature ranges of the refrigerating and freezing compartments are reduced to a less cool condition and the speeds of the refrigerating compartment and freezing compartment fans are set to constant low values.

Still according to the other aspect of the invention, the control means is constructed to allow the refrigerating appliance to selectively operate in a "party mode", according to which the operational temperature range is adjusted to its cooler value and the speed of the refrigerating compartment fan is set to a constant maximum value.

Brief Description of the Drawings

The invention will be described below with reference to the enclosed drawings, given by way of example of possible embodiments of the invention and in which:

Figure 1 is a schematic median vertical sectional view of a combined refrigeration appliance provided with the control system of the present invention; and Figures 2 and 2a illustrate, jointly, a block diagram showing the processing steps which are carried out by the control means to effect the settings in the operation of the refrigeration appliance.

Detailed Description of the Invention

As mentioned above, the present refrigeration control system is applied to a combined refrigeration appliance whose cabinet defines, internally, a refrigerating compartment R and a freezing compartment F which are respectively closed by front doors 11, 12. In the interior of at least one of the refrigerating compartment R and freezing compartment F is provided an evaporator 20 which in the illustrated embodiment

is positioned in the internal rear region of the freezing compartment F. The refrigerating compartment R is provided with a refrigerating compartment temperature sensor Sr and the freezing compartment
5 with a freezing compartment temperature sensor Sf, said temperature sensors being operatively associated with a control means 30 adequately secured to the cabinet 10 usually in the lower rear portion of the latter.

10 Cabinet 10 further houses a refrigerating compartment fan 40 and a freezing compartment fan 50 which are positioned and dimensioned to produce respective forced air flows through the evaporator 20 and through the refrigerating and freezing compartments R and F,
15 respectively. The refrigerating compartment and freezing compartment fans 40 and 50 are operatively associated with the control means 30, which is also operatively coupled to a compressor 60 of the refrigeration system of the refrigeration appliance.

20 The construction defined above allows the control means 30 to activate and deactivate the compressor 60 and the refrigerating compartment and freezing compartment fans 40 and 50 as a function of the activation and deactivation temperatures detected by
25 the refrigerating compartment and freezing compartment sensors Sr and Sf.

According to the invention, the control means 30 is operatively associated with the refrigerating compartment fan 40 to adjust, selectively and
30 periodically, the speed of the latter, in order to make the temperature of the refrigerating compartment R, detected by the refrigerating compartment temperature sensor Sr, to reach a deactivation value of the refrigerating compartment fan 40 substantially
35 at the same time in which the temperature of the

freezing compartment F, detected by the freezing compartment temperature sensor Sf, reaches a deactivation value of the freezing compartment fan 50 and of the compressor 60.

- 5 The concept used in the present invention is mainly based on the periodic adjustment of the speed of the refrigerating compartment fan 40, in order to make the cooling of the refrigerating compartment R to end at the same time of the cooling of the freezing
- 10 compartment F, whereby the respective refrigerating compartment and freezing compartment temperature sensors Sr and Sf will simultaneously inform the control means 30 that the deactivation temperatures of both the refrigerating compartment fan 40 and the
- 15 freezing compartment fan 50 jointly with the deactivation of compressor 60 have been reached. The balance in the cooling time of the refrigerating and freezing compartments R and F leads to a synchronized operation of both the refrigerating compartment fan 40
- 20 and the freezing compartment fan 50 with the compressor 60 consequently operating in periodic regular cycles, allowing an optimized energy consumption to be obtained in terms of compressor operation.
- 25 Particularly, the selective and periodic adjustment of the speed of the refrigerating compartment fan 40 occurs whenever the ratio between the cooling detected in the refrigerating compartment R and measured from the activation temperature and the maximum cooling
- 30 defined between the activation and deactivation temperatures of the refrigerating compartment fan 40 differs by an absolute value higher than a determined balance value from the ratio, between the cooling of the freezing compartment F measured from the
- 35 activation temperature and the maximum cooling defined

between the activation and deactivation temperatures of the freezing compartment fan 50.

Said balance value between the cooling ratios detected in the refrigerating and freezing compartments R and F
5 can be defined by a variation from about 5% to about 20% between said ratios, i.e., while the variation between the cooling ratios remains within about higher or lower values from about 5% to about 20%, the control means 30 will maintain the speed of the
10 refrigerating compartment fan 40 unaltered, modifying said speed to higher or lower values when said difference between both cooling ratios surpasses the exemplary balance value of about 5% to about 20%.

According to the invention, the speed of the
15 refrigerating compartment fan 40 is increased when the cooling ratio in the refrigerating compartment R is more than about 5% to about 20% lower than the cooling ratio of the freezing compartment F and also when the relation between the cooling ratio of the
20 refrigerating compartment R and the cooling ratio of the freezing compartment F is negative. On the other hand, the speed of the refrigerating compartment fan 40 is reduced when the cooling ratio of the refrigerating compartment R is more than about 5% to
25 about 20% higher than the cooling ratio of the freezing compartment F.

The periodic speed settings of the refrigerating compartment fan 40 are achieved, when necessary, by speed variations which represent a percentage, for
30 example of about 10% the nominal speed of the refrigerating compartment fan 40.

Considering that the control means 30 can be constructed to compare the cooling ratios of both the refrigerating compartment R and the freezing
35 compartment F in time intervals of five minutes for

example, the need for adjusting the speed of the refrigerating compartment fan 40 can be checked in said time intervals during each operating period of the compressor, allowing that at each check the speed of the refrigerating compartment fan 40 can be varied by the necessary increase or reduction, in order to progressively approximate the cooling ratio of the refrigerating compartment R to the cooling ratio of the freezing compartment F.

According to one way of carrying out the present invention, the setting of the speed of the refrigerating compartment fan 40 is effected by the control means 30 from a calculation using the following mathematical expression:

$$\frac{dF}{dR} = \frac{\frac{T_{sf} - T_{af}}{T_{df} - T_{af}}}{\frac{T_{sr} - T_{ar}}{T_{dr} - T_{ar}}}$$

In the mathematical expression above, dF is the cooling ratio of the freezing compartment F, while dR is the cooling ratio of the refrigerating compartment R. The cooling ratio dF of the freezing compartment F is obtained by dividing the difference between the activation temperature Taf of the freezing compartment fan 50 in the freezing compartment F and the sensed temperature Tsf in said freezing compartment F by the difference between the activation Taf and deactivation Tdf temperatures of the freezing compartment fan 50 in said freezing compartment F. Similarly, the cooling ratio dR of the refrigerating compartment R is obtained by dividing the difference between the activation temperature Tar of the refrigerating compartment fan 40 in the refrigerating compartment R and the sensed temperature Tsr in said refrigerating

compartment R by the difference between the activation T_{ar} and deactivation T_{dr} temperatures in the refrigerating compartment fan 40.

Thus, the numerator of said mathematical expression
 5 shows how much the freezing compartment F has been cooled and how much it is close to reach the deactivation temperature T_{df} in which the compressor 60 and the freezing compartment fan 50 will be deactivated.

10 In an analogous way, the denominator of said mathematical expression shows how much the refrigerating compartment R has been cooled and how much it is close to reach the deactivation temperature T_{dr} in which the refrigerating compartment fan 40 is
 15 deactivated.

The quotient of the cooling ratios dR , dF gives a relative comparison of said compartments, informing how much each compartment has been cooled during its cooling process until the deactivation temperatures
 20 T_{dr} and T_{df} of the respective refrigerating compartment fan 40 and freezing compartment fan 50 have been reached.

The control means 30 is preferably programmed to evaluate the expression above at each operating time
 25 period of about 1-5 minutes, commanding the adjustment of the speed of the refrigerating compartment fan 40 in the same frequency and according to the table given below, considering the balance value as being for example 10%:

$dF/dR \leq 0$	increases the speed
$0 < dF/dR \leq 0.9$	reduces the speed
$0.9 < dF/dR < 1.1$	maintains the speed
$dF/dR \geq 1.1$	increases the speed
$dF/dR = \text{div}/0$	maintains the speed

30 At the end of the operating time of one cycle of the

compressor 60, the control means 30 records the speed of the refrigerating compartment fan 40 and uses it as the initial speed in the next operating cycle of the compressor 60. Thus, a transient situation persists in the first cycles until the control means 30 finds the adequate initial speed for the synchronization of the operating cycles of the refrigerating 40 and freezing compartment fans. From this moment on, the permanent regime is established and the cyclic operation, in the ideal conditions to reduce energy consumption, is repeated.

Obviously, events such as door opening and storage or removal of load in relation to the refrigeration appliance will tend to alter the permanent regime state and/or make the refrigerating compartment fan 40 be activated in the periods in which the compressor 60 is deactivated. These events characterized by a substantial temperature rise of the refrigerating compartment temperature sensor S_r cannot be disregarded by the control system, which otherwise could greatly upset the user.

Thus, the control system is programmed to activate the refrigerating compartment fan 40 even with the compressor 60 being deactivated, when the temperature of the refrigerating compartment R reaches a predetermined limit value that is above the activation temperature T_{ar} of the refrigerating compartment fan 40. Thus, the control system gives priority to the performance of the refrigerating compartment in detriment of the synchronization of the fans, when such synchronization is capable of producing a prejudicial unbalance in the operational temperature of the refrigerating compartment R.

Another important aspect of the present control system is the protection which allows the temperature of the

refrigerating compartment R to remain the more stable possible. Some "loss of control" in the temperature of the refrigerating compartment R can occur when the refrigerating compartment fan 40 is prevented from
5 being activated and the temperature T_{sr} detected by the refrigerating compartment temperature sensor S_r is above the activation temperature T_{ar} of said refrigerating compartment fan 40, but below the predetermined limit value from which the refrigerating
10 compartment fan 40 is activated independently of the state in which the compressor 60 is found. Such "loss of control" is characterized by the elevation of the medium temperature of the refrigerating compartment R when, in some circumstances, the refrigerating
15 compartment fan 40 is activated, in the start of the activation cycle of the compressor, by several successive cycles above its activation temperature T_{ar} .

In order to provide a protection against this
20 undesirable situation, the control system is programmed to reduce the deactivation temperature T_{dr} of the refrigerating compartment fan 40 during at least one operating cycle of the latter, whenever it is activated at least two consecutive times and with
25 the temperature of the refrigerating compartment R situated between the activation temperature T_{ar} of the refrigerating compartment fan 40 and the predetermined limit value.

The present refrigeration control system further
30 allows the user to adjust the operation of the fans and consequently of the compressor 60 to a reduced and temporary special usage pattern which commonly occurs in periods of vacation or trips during which the refrigeration appliance operates without any
35 modification occurring in its inner load or without

any of its doors being opened.

Thus, the control means 30 is constructed so that it can be optionally and selectively conducted to operate in a "vacation" mode, according to which the
5 activation temperatures T_{ar} , T_{af} and deactivation temperatures T_{dr} and T_{df} of the refrigerating compartment fan 40 and the freezing compartment fan 50 are raised to a "less cool" condition and the speed of the said refrigerating compartment fan 40 and freezing
10 compartment fan 50 are set to constant reduced values. The benefit to the user is translated in energy saving during the time in which the "vacation" function or mode is activated. The user activates this function through the electronic control panel and the duration
15 period is indefinite, lasting until the function is deactivated or until one of the doors 11 or 12 of the refrigeration appliance is opened.

In accordance with one more aspect of the invention, the control means 30 can be optionally and selectively
20 conducted, by the user instructing an electronic control panel of the refrigeration appliance to work in a "party" mode, in which: the activation temperature T_{ar} and deactivation temperature T_{dr} of the refrigerating compartment fan 40 are reduced to a
25 cooler condition; the activation temperature T_{af} and deactivation temperature T_{df} of the freezing compartment fan 50 are maintained in the operating condition originally selected by the user for the refrigeration appliance; the speed of the
30 refrigerating compartment fan 40 is set to a maximum value; and the speed of the freezing compartment fan 50 is maintained in a constant reduced value.

The actions resulting from the party mode lead to a total priority of the refrigerating compartment R in
35 detriment of the freezing compartment F. The freezing

compartment F remains operating normally, according to the operational temperature selected by the user, it being understood that its operating condition is not adequate to great demands in relation to door openings and relevant loadings.

The refrigerating compartment R, on its turn, operates in the most favorable condition, to positively and rapidly respond to great demands, keeping the stored foods and beverages in adequate conditions and propitiating a more efficient cooling of the load to be replaced.

The user activates the party mode through the electronic control panel of the refrigeration appliance, and the deactivation occurs automatically after a determined period of time has elapsed, for example six hours, after which the refrigeration appliance will return completely to its operating mode being used before the activation of the party mode.

Figures 2 and 2a of the appended drawings illustrate, jointly and in block diagrams, the operation of the refrigeration control system of a combined refrigeration appliance of the type illustrated in figure 1 described above.

As already mentioned, the control means 30 is operatively associated with the refrigerating compartment fan 40 and freezing compartment fan 50 and to the refrigerating compartment and freezing compartment temperature sensors Sr and Sf and also with the compressor 60, in order to drive said fans and the compressor according to the temperature parameters informed to the control means 30 through the refrigerating compartment and freezing compartment temperature sensors Sr and Sf. The control means 30 is provided with a clock of adequate construction (not illustrated) and is also operatively associated with a

control panel (not illustrated) of the refrigeration appliance which functions as an interface between said appliance and the user, so that the latter can modify or set the operational characteristics of the
5 refrigeration appliance.

In the block diagrams of figures 2 and 2a, the references in alphabetic characters are the ones already used during the present description, it being only necessary to further consider the following
10 additional references: Counter Tout = counter for the number of times the compressor is activated with $T_{sr} > T_{ar}$; Tout = temperature to be diminished from the original value of the temperature deactivation of the refrigerating compartment fan 40 Tdf; T = temperature
15 difference between T_{sr} and T_{ar} , above which the refrigerating compartment fan 40 turns on, even if the compressor 60 is switched off; and t_a = time interval between successive speed settings of the refrigerating compartment fan 40.

20 As illustrated in figure 2, the control system is initiated from a condition in which the compressor 60 and the refrigerating compartment and freezing compartment fans 40, 50 are switched off with the counter of the number of times the compressor is
25 activated with $T_{sr} > T_{ar}$ indicating a null value of times in which the appliance has been driven in this particular condition.

Once the initial conditions cited above have been established, the control means 30 promotes reading of
30 the temperatures of the freezing compartment sensor Sf and refrigerating compartment sensor Sr and subsequently compares the value of the temperature T_{sr} sensed in the refrigerating compartment R with the sum of the activation temperature T_{ar} of the refrigerating
35 compartment fan 40 with the temperature difference

between the temperature values T_{sr} sensed in the refrigerating compartment R and the activation temperature T_{ar} of the refrigerating compartment fan 40. In case the comparison above indicates a temperature T_{sr} higher than or equal to said sum, the control means 30 instructs the refrigerating compartment and freezing compartment fans 40, 50 to operate, maintaining the compressor still switched off. In this step of the control system, the working speed of the refrigerating compartment fan 40 is established in the value of the last speed applied thereto or in the value of a default speed.

Once the speed of the refrigerating compartment fan 40 has been established, the control means 30 compares the values of the temperature T_{sf} of the freezing compartment F with the activation temperature T_{af} of the freezing compartment fan 50. If the temperature T_{sf} of the freezing compartment F is superior or equal to the value of said activation temperature T_{af} , the control means 30 instructs both the compressor 60 and the freezing compartment fan 50 to operate. If the temperature T_{sf} of the freezing compartment F is lower than the activation temperature T_{af} of the freezing compartment fan 50, the system returns to the step of comparing the values between the temperature T_{sr} of the refrigerating compartment R and the sum of the activation temperatures T_{ar} of the refrigerating compartment fan 40 and the difference of the temperatures T_{fr} and T_{ar} . In case the temperature T_{sr} of the refrigerating compartment R is inferior to said sum of the activation temperature T_{ar} with the difference between the temperatures T_{sr} and T_{ar} , the control system further instructs the control means 30 to pass to the step of comparing the temperatures T_{sf} of the freezing compartment F and the activation

temperature T_{af} of the freezing compartment fan 50.
Once the compressor 60 and the freezing compartment fan 50 are switched on, the control means 30 checks whether the temperature T_{sr} of the refrigerating compartment R is superior or equal to the activation temperature T_{ar} of the refrigerating compartment R. In case T_{sr} is superior or equal to T_{ar} , the control means 30 checks whether the number of times in which the compressor is driven with $T_{sr} \geq T_{ar}$ is higher than or equal to 2. If this situation occurs, the control means will keep the deactivation temperature T_{dr} of the refrigerating compartment fan 40 equal to the original deactivation temperature of said refrigerating compartment fan 40. In this case, it is not necessary to vary the deactivation temperature T_{dr} of the refrigerating compartment fan 40, being zero the temperature to be diminished from the original value of said deactivation temperature T_{dr} , whereby the equation $T_{dr} = T_{dr} - T_{out}$ results in temperature T_{dr} being adjusted by the control means 30 to be equal to the temperature T_{dr} originally set by the user in the control panel, for the operation of the refrigeration appliance.

Once the conditions above have been observed, the control means 30 switches on the refrigerating compartment fan 40.

On the other hand, if the control means 30 verifies the temperature T_{sr} of the refrigerating compartment R is lower than the deactivation temperature T_{dr} of the refrigerating compartment fan 40, the control means 30 switches off the refrigerating compartment fan 40, and the control system returns to the previous step, in which the control means 30 instructs both the compressor 30 and the freezing compartment fan 50 to operate. If the temperature T_{sr} is higher than or

equal to T_{ar} , the control means 30 keeps the deactivation temperature T_{dr} of the refrigerating compartment fan 40 equal to the temperature T_{dr} originally established or set for the operation of the refrigeration appliance, and the control means 30 then instructs the refrigerating compartment fan 40 to operate.

Upon occurring the operational situation described above, the control means 30 instructs the refrigerating compartment fan 40 to operate in the speed previously applied thereto or in the default speed established in the project. Then, the control means 30 verifies the dF/dR relation between the cooling ratios of the freezing compartment F and of the refrigerating compartment R, respectively. The control means 30 verifies the different conditions illustrated in the median block of figure 2a. Thus, considering the exemplary value of 10% for the balance value for said cooling ratios, if the dF/dR ratio is zero, the control means 30 raises the speed of the refrigerating compartment fan 40. If the dF/dR ratio is higher than zero and lower than or equal to 0.9, the control means 30 reduces the speed of the refrigerating compartment fan 40. If the dF/dR ratio is higher than 0.9 and lower than 1.1, the control means 30 maintains the speed of the refrigerating compartment fan 40 unaltered. If the dF/dR ratio is superior or equal to 1.1, the control means 30 raises the speed of said refrigerating compartment fan 40 and if said ratio is equal to the ratio resulting from a division by zero, the control means 30 will also maintain the speed of the refrigerating compartment fan 40 unaltered.

The control means 30 then verifies, in a subsequent step, whether the temperature T_{sf} of the freezing

compartment F is lower than the deactivation temperature Tdf of the freezing compartment fan 50. In case said operational condition occurs, the control means 30 switches off the compressor 60 and checks
5 whether the temperature Tsr of the refrigerating compartment R is superior or equal to the sum of the activation temperature Tar of the refrigerating compartment fan 40 with the difference between the temperatures Tsr and Tar. In case such condition does
10 not occur, the control means 30 switches off the freezing compartment fan 50 and the refrigerating compartment fan 40, maintaining the deactivation temperature Tdr of the refrigerating compartment fan 40 equal to the temperature Tdr originally set for the
15 refrigeration appliance and returns to the beginning of the control system operation.

In case the control means 30 verifies the occurrence of the $Tsr \geq Tar + T$ condition, it drives the freezing compartment fan 50 and refrigerating
20 compartment fan 40, turning off the compressor 60 and returning to the step of the control process in which the control means 30 restores the speed of the refrigerating compartment fan 40, keeping it equal to a value previously used or applying the default speed
25 designed for the system.

On the other hand, in case the control means 30 verifies that the temperature Tsf of the freezing compartment F is higher than or equal to the deactivation temperature Tdf of the freezing
30 compartment fan 50, it switches off the refrigerating compartment fan 40 and checks whether the temperature Tsr of the refrigerating compartment R is superior or equal to the activation temperature Tar of the refrigerating compartment fan 40. If the $Tsr < Tar$
35 condition occurs, the control means 30 returns the

system to the condition in which it promotes the operation of the refrigerating compartment fan 40, either in the previous speed or in the default speed. In the hypothesis the refrigerating compartment fan 40 is switched off and $T_{sr} < T_{ar}$, the control means 30 verifies whether the temperature of the refrigerating compartment R is lower than the deactivation temperature T_{de} of the refrigerating compartment fan 40. If this condition occurs, the control means 30 switches off both the refrigerating 40 and the freezing 50 fans and switches off the compressor 60, maintaining the deactivation temperature T_{dr} of the refrigerating compartment fan 40 equal to the original deactivation temperature T_{dr} of said fan, returning the control system to the step in which the control means 30 verifies whether the temperature T_{sf} of the freezing compartment F is lower than the deactivation temperature T_{df} of the freezing compartment fan 50. If the control means detects a temperature T_{sr} of the refrigerating compartment R higher than or equal to the deactivation temperature T_{dr} of the refrigerating compartment fan 40, it will further verify whether the refrigerating compartment fan 40 is switched on. If said refrigerating compartment fan 40 is switched off, the control means 30 returns the process to said step of comparing the temperature T_{sf} of the freezing compartment F with the deactivation temperature T_{df} of the freezing compartment fan 50. If the refrigerating compartment fan 40 is on, the control means 30 verifies whether the speed setting time of the refrigerating compartment fan 40 is superior or equal to the time interval T_a between successive speeds settings of said fan. In case the comparison of said times does not occur, the control means 30 returns the control system to the

step of comparing the temperature T_{sf} of the freezing compartment F with the deactivation temperature T_{df} of the freezing compartment fan 50. If said speed setting time/time interval T_a relation occurs, the control
5 means 30 returns the system to the step of verifying the relation between the cooling ratio T_f of the freezing compartment F and the cooling ratio T_r of the refrigerating compartment R.

10 While only one way of carrying out the invention has been described and illustrated herein, it should be understood that alterations in the form and arrangement of the component parts of the control system could be made, without departing from the protective scope defined by the appended claims.

CLAIMS

1. A refrigeration control system in combined refrigeration appliances of the type comprising: a refrigerating compartment (R) provided with at least
5 one refrigerating compartment temperature sensor (Sr); a freezing compartment (F) provided with a freezing compartment temperature sensor (Sf); a compressor (60); an evaporator (20); a refrigerating compartment fan (40) and a freezing compartment fan (50) to
10 produce respective forced air flows through the evaporator (20) and through the refrigerating compartment (R) and the freezing compartment (F), respectively; and a control means (30) to activate and deactivate the compressor (60) and the refrigerating
15 compartment fan (40) and freezing compartment fan (50) as a function of the activation and deactivation temperatures (Tar, Taf, Tdr, Tdf) detected by the refrigerating compartment temperature sensor (Sr) and the freezing compartment temperature sensor (Sf),
20 characterized in that the control means (30) is operatively associated with the refrigerating compartment fan (40) to selectively and periodically adjust the speed of the latter, so that the temperature of the refrigerating compartment (R)
25 detected by the refrigerating compartment temperature sensor (Sr) reaches a deactivation value of the refrigerating compartment fan (40) at the same time in which the temperature of the freezing compartment (F) detected by the freezing compartment temperature
30 sensor (Sf) reaches a deactivation value of both the freezing compartment fan (50) and the compressor (60).

2. The refrigeration control system according to claim 1, characterized in that the selective and periodic adjustment of the speed of the refrigerating
35 compartment fan (40) occurs whenever the ratio between

the cooling detected in the refrigerating compartment (R) and measured from the activation temperature and the maximum cooling defined between the activation (Tar) and deactivation (Tdr) temperatures of the refrigerating compartment fan (40) differs by an absolute value higher than a determined balance value from the ratio between the cooling in the freezing compartment (F) measured from the activation temperature and the maximum cooling defined between the activation (Taf) and deactivation (Tdf) temperatures of the freezing compartment fan (50).

3. The refrigeration control system according to claim 2, characterized in that the balance value between the cooling ratios detected in the refrigerating (R) and freezing (F) compartments is defined by a variation from about 5% to about 20% between said ratios.

4. The refrigeration control system according to claim 3, characterized in that the speed of the refrigerating compartment fan (40) is increased when the cooling ratio in the refrigerating compartment (R) is more than about 5% to about 20% lower than the cooling ratio in the freezing compartment (F) and also when the relation between the cooling ratio of the refrigerating compartment (R) and the cooling ratio of the freezing compartment is negative.

5. The refrigeration control system according to claim 3, characterized in that the speed of the refrigerating compartment fan (40) is reduced when the cooling ratio in the refrigerating compartment (R) is more than about 5% to about 20% higher than the cooling ratio in the freezing compartment (F).

6. The refrigeration control system according to claim 4 or 5, characterized in that the periodic adjustments in the speed of the refrigerating compartment fan (40) are effected by speed variations representing a

percentage of the nominal speed of the refrigerating compartment fan (40).

7. The refrigeration control system according to claim 6, characterized in that the speed variation
5 percentage in each speed variation is of about 10%.

8. The refrigeration control system according to claim 2, characterized in that the control means (30)
10 compares the cooling ratios of both the refrigerating compartment (R) and the freezing compartment (F) at each period of about one to five minutes, in order to detect the need for adjusting the speed of the refrigerating compartment fan (40).

9. The refrigeration control system according to claim 1, characterized in that the control means (30)
15 instructs the refrigerating compartment fan (40) to operate with an initial speed that is equal to the last operating speed when the deactivation temperature of the refrigerating compartment fan (40) in the refrigerating compartment (40) has been reached.

20 10. The refrigeration control system according to claim 1, characterized in that the control means (30) activates the refrigerating compartment fan (40), even with the compressor (60) being deactivated, when the temperature (T_{sr}) sensed in the interior of the
25 refrigerating compartment (R) reaches a predetermined temperature limit value higher than the activation temperature (T_{ar}) of the refrigerating compartment fan (40).

30 11. The refrigeration control system according to claim 10, characterized in that the control means (30) reduces the deactivation temperature (T_{dr}) of the refrigerating compartment (R) during at least one operating cycle of the latter, whenever it is activated for at least two consecutive times, with the
35 temperature of the refrigerating compartment (R) being

situated between the activation temperature (T_{ar}) of the refrigerating compartment fan (40) and the predetermined limit value.

12. The refrigeration control system according to claim 1, characterized in that the control means (30) is operationally and selectively conducted by the user to operate in a "vacation mode", according to which the activation temperatures (T_{ar} , T_{af}) and the deactivation temperatures (T_{dr} , T_{df}) of both the refrigerating compartment fan (40) and the freezing compartment fan (50) are raised to a less cold condition and the speeds of both the refrigerating compartment fan (40) and the freezing compartment fan (50) are set to constant and reduced values.

13. The refrigeration control system according to claim 12, characterized in that the "vacation mode" is maintained by the control means (30) until the occurrence of one of the actions of the user deactivating said mode in an electronic control panel of the refrigeration appliance and of opening any one of the two doors (11, 12) of the cabinet (10).

14. The refrigeration control system according to claim 1, characterized in that the control means (30) is operationally and selectively conducted by the user instructing an electronic control panel of the refrigerating appliance to work in a "party mode", according to which the activation (T_{ar}) and deactivation (T_{dr}) temperatures of the refrigerating compartment fan (40) are reduced to a cooler condition; the activation (T_{af}) and deactivation (T_{df}) temperatures of the freezing compartment fan (50) are kept in the operational condition originally selected by the user for the refrigeration appliance; the speed of the refrigerating compartment fan (40) is set to a maximum value; and the speed of the freezing

compartment fan (50) is maintained in a constant and reduced value.

15. The refrigeration control system according to claim 14, characterized in that the "party mode" is maintained by a predetermined period, at the end of which the refrigeration appliance returns to the operating mode prior to the activation of the "party mode".

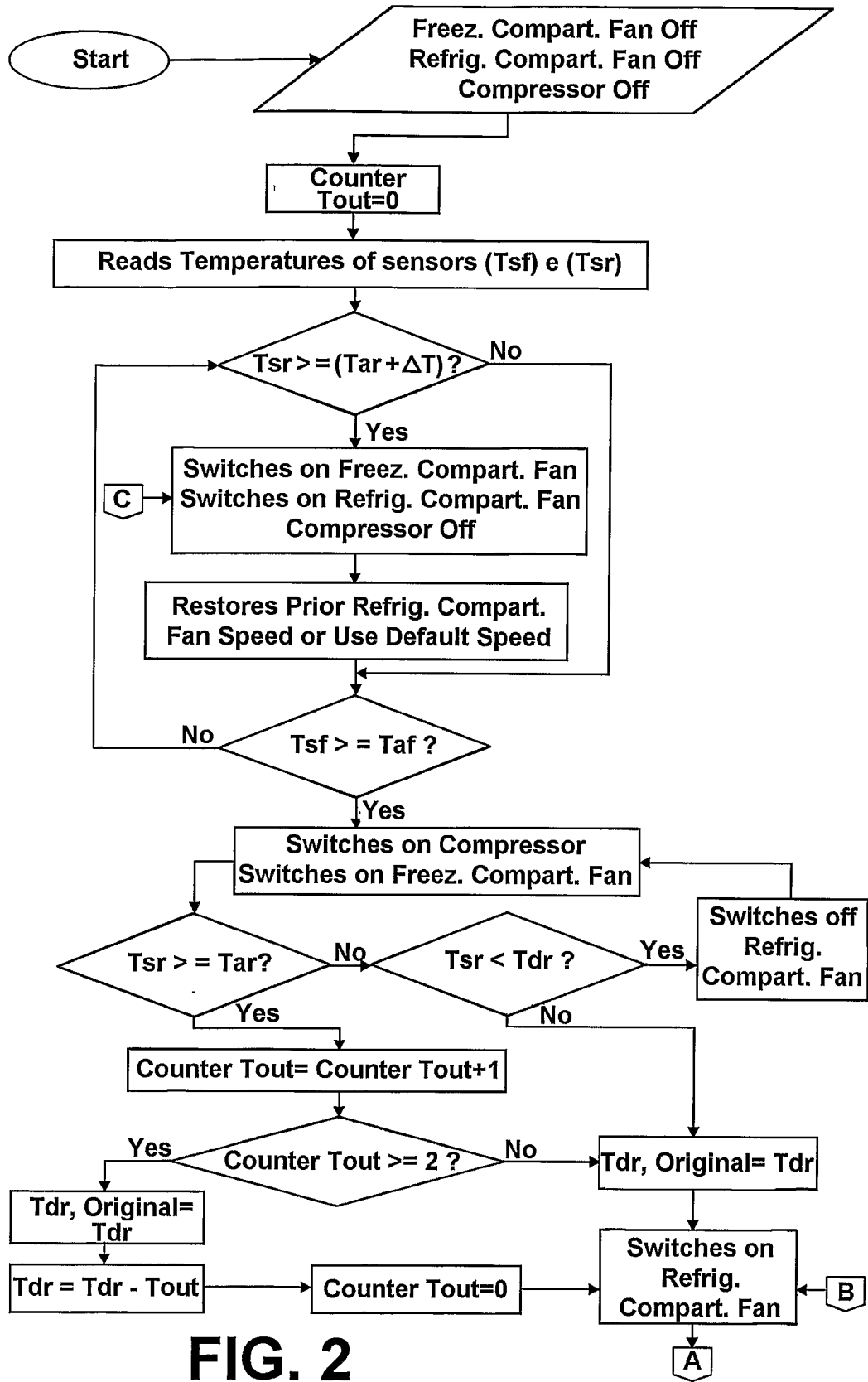

FIG. 2

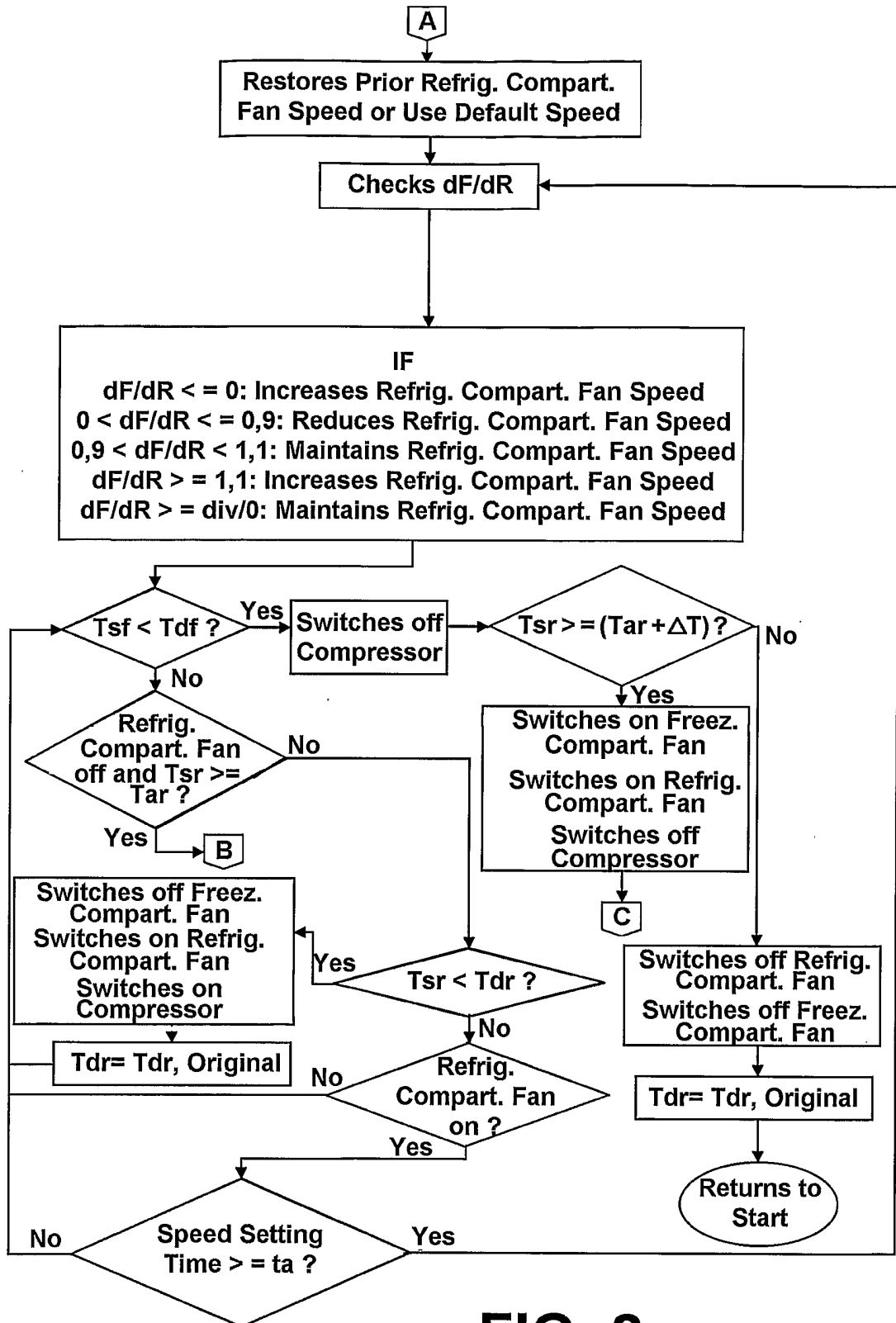

FIG. 2a