



- (51) **International Patent Classification:**
H01R 39/08 (2006.01)
- (21) **International Application Number:**
PCT/CN2024/108101
- (22) **International Filing Date:**
29 July 2024 (29.07.2024)
- (25) **Filing Language:** English
- (26) **Publication Language:** English
- (30) **Priority Data:**
202310946143.0 28 July 2023 (28.07.2023) CN
- (71) **Applicant:** SHANGHAI UNITED IMAGING HEALTHCARE CO., LTD. [CN/CN]; No. 2258 Chengbei Road, Jiading District, Shanghai 201807 (CN).
- (72) **Inventor:** DUAN, Junlong; No. 2258 Chengbei Road, Jiading District, Shanghai 201807 (CN).
- (74) **Agent:** METIS IP (CHENGDU) LLC; Room 401, 4th Floor, Unit 1 of Building 1, No. 269 North Section of Hu-

pan Road, Tianfu New District, China Free Trade Zone (Sichuan), Chengdu, Sichuan 610213 (CN).

(81) **Designated States** (unless otherwise indicated, for every kind of national protection available): AE, AG, AL, AM, AO, AT, AU, AZ, BA, BB, BG, BH, BN, BR, BW, BY, BZ, CA, CH, CL, CN, CO, CR, CU, CV, CZ, DE, DJ, DK, DM, DO, DZ, EC, EE, EG, ES, FI, GB, GD, GE, GH, GM, GT, HN, HR, HU, ID, IL, IN, IQ, IR, IS, IT, JM, JO, JP, KE, KG, KH, KN, KP, KR, KW, KZ, LA, LC, LK, LR, LS, LU, LY, MA, MD, MG, MK, MN, MU, MW, MX, MY, MZ, NA, NG, NI, NO, NZ, OM, PA, PE, PG, PH, PL, PT, QA, RO, RS, RU, RW, SA, SC, SD, SE, SG, SK, SL, ST, SV, SY, TH, TJ, TM, TN, TR, TT, TZ, UA, UG, US, UZ, VC, VN, WS, ZA, ZM, ZW.

(84) **Designated States** (unless otherwise indicated, for every kind of regional protection available): ARIPO (BW, CV, GH, GM, KE, LR, LS, MW, MZ, NA, RW, SC, SD, SL, ST, SZ, TZ, UG, ZM, ZW), Eurasian (AM, AZ, BY, KG, KZ, RU, TJ, TM), European (AL, AT, BE, BG, CH, CY, CZ, DE, DK, EE, ES, FI, FR, GB, GR, HR, HU, IE, IS, IT, LT, LU, LV, MC, ME, MK, MT, NL, NO, PL, PT, RO, RS, SE,

(54) **Title:** NON-CONTACT TRANSMISSION SYSTEMS AND MEDICAL SYSTEMS

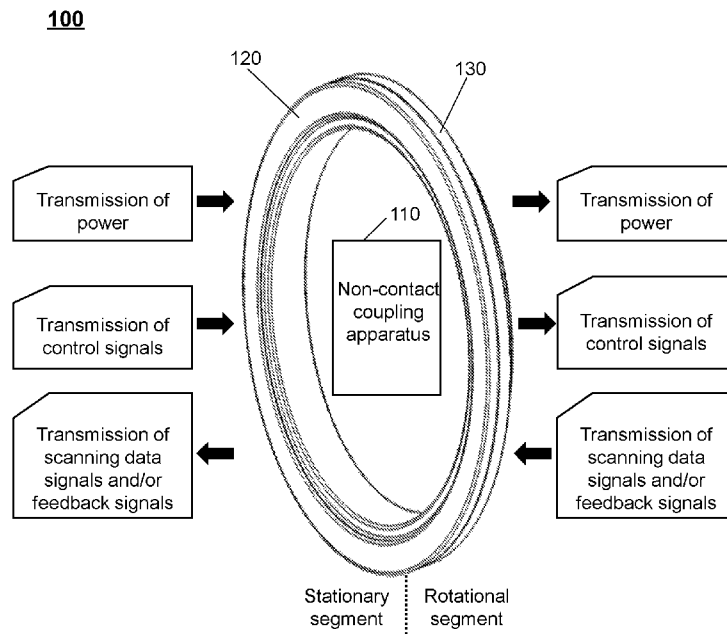

FIG. 1A

(57) **Abstract:** The present disclosure provides a non-contact transmission system, applied to medical system, comprising a stationary segment, a rotational segment and a non-contact coupling apparatus. A primary side of the non-contact coupling apparatus is connected with the stationary segment. A secondary side of the non-contact coupling apparatus is connected with the rotational segment. The non-contact coupling apparatus is configured to implement transmission of power and signals between the stationary segment and the rotational segment.



SI, SK, SM, TR), OAPI (BF, BJ, CF, CG, CI, CM, GA, GN,
GQ, GW, KM, ML, MR, NE, SN, TD, TG).

Published:

— *with international search report (Art. 21(3))*

NON-CONTACT TRANSMISSION SYSTEMS AND MEDICAL SYSTEMS**CROSS REFERENCE TO RELATED APPLICATIONS**

[0001] This application claims priority to Chinese Application No. 202310946143.0, filed on July 28, 2023, the entire contents of which are incorporated herein by reference.

TECHNICAL FIELD

[0002] The present disclosure relates to the field of electromagnetic resonant coupling power transfer, and in particular to a non-contact transmission system and a medical system.

BACKGROUND

[0003] Medical systems (e.g., Computed Tomography (CT) equipment, Positron Emission Tomography Computed Tomography (PET-CT) equipment, Single-Photon Emission Computed Tomography equipment, and Radiotherapy equipment) that include a gantry usually use a slip ring with a brush contact (e.g., a carbon brush) to implement transmission of power and signals between a rotational segment and a stationary segment. The slip ring usually requires multiple conductive tracks (e.g., metal rails) and leads to high material costs. The carbon brush commonly used in the brush contact exposes problems of wear and carbon powder accumulation on the track surfaces and surrounding accessories or components. Carbon powder flows with the heat dissipation airflow inside the rack of the medical system, and has a wide adhesion surface and random adhesion thereof. As the medical system is used for a long time, the cost of cleaning and maintaining the carbon powder in the gantry gradually increases. In addition, there is a probability of sparking in the contact area between the carbon brush and the metal track due to high voltage and high current, which poses a safety hazard.

SUMMARY

[0004] The embodiments of the present disclosure provide a non-contact transmission system, applied to medical system, comprising a stationary segment, a rotational segment, and a non-contact coupling apparatus. A primary side of the non-contact coupling apparatus may be connected with the stationary segment. A secondary side of the non-contact coupling apparatus may be connected with the rotational segment. The non-contact coupling apparatus may be configured to implement transmission of power and signals between the stationary segment and the rotational segment.

[0005] In some embodiments, the non-contact coupling apparatus may include at least one pair of coil windings. The at least one pair of coil windings may be configured to implement transmission of power and signals between the stationary segment and the rotational segment.

[0006] In some embodiments, the at least one pair of coil windings may include: a first coil winding pair, configured to implement a transmission of power from the stationary segment to the rotational segment to supply power to one or more main power consumption devices of the rotational segment and/or one or more auxiliary power devices of the rotational segment; a second coil winding pair, configured to implement a transmission of one or more control signals from the stationary segment to the rotational segment; and a third coil winding pair, configured to transmit scanning data signals and/or feedback signals from the rotational segment to the stationary segment.

[0007] In some embodiments, the at least one pair of coil windings may include: a first coil winding pair, configured to implement a transmission of first power from the stationary segment to the rotational segment to supply power to one or more main power consumption devices of the rotational segment; a second coil winding pair, configured to implement a transmission of second power from the stationary segment to the rotational segment, and a transmission of one or more control signals from the stationary segment to the rotational segment, the second power being configured to supply power to one or more auxiliary power devices of the rotational segment; and a third coil winding pair, configured to transmit scanning data signals and/or feedback signals from the rotational segment to the stationary segment.

[0008] In some embodiments, the first power may be a large-scale power stream, the second power may be a small-scale power stream.

[0009] In some embodiments, the stationary segment may include a high-frequency AC voltage output circuit, the rotational segment may include a main power output circuit. A first primary coil of the first coil winding pair may be connected with the stationary segment, and a first secondary coil of the first coil winding pair may be connected with the rotational segment. The high-frequency AC voltage output circuit may be connected with an external power supply and the first primary coil and the main power output circuit may be connected with the first secondary coil and the one or more main power consumption devices.

[0010] In some embodiments, the high-frequency AC voltage output circuit may include an isolation transformer, a first rectifier and filter, and a first inverter connected in sequence. The stationary segment may further include a drive circuit controller. The drive circuit controller may be configured to control a set of power semiconductor switch components of the first inverter to adjust a real-time output voltage of the high-frequency AC voltage output circuit.

[0011] In some embodiments, the stationary segment may include a first power line carrier modulation circuit, a DC/DC converter, and a second inverter. The rotational segment may include a carrier signal extraction and envelope detection demodulation circuit. A second primary coil of the second coil winding pair may be connected with the stationary segment, and a second secondary coil of the second coil winding pair may be connected with the rotational segment. The first power line carrier modulation circuit may be configured to control a real-time output voltage of the DC/DC converter based on the control signal of the stationary segment. The output voltage of the DC/DC converter may be transmitted to the second secondary coil through the second primary coil. The carrier signal extraction and envelope detection demodulation circuit may be configured to extract an envelope from the output voltage received from the second secondary coil and demodulate the envelope into digital signals.

[0012] In some embodiments, a ratio of winding turns of the first primary coil to the first secondary coil of the first coil winding pair may be 1:1.5; a ratio of winding turns of the second primary coil to the second secondary coil of the second coil winding pair may be 1:1.5; and/or a ratio of winding turns of the third primary coil to the third secondary coil of the third coil winding pair may be 1:1.

[0013] In some embodiments, a first distance between the first coil winding pair and the second coil winding pair may be greater than a second distance between the second coil winding pair and

the third coil winding pair.

[0014] In some embodiments, the at least one pair of coil windings may include one or more pairs of axially-coupled coil windings and/or one or more pairs of radially-coupled coil windings.

[0015] In some embodiments, a spacing between a primary coil and a secondary coil of each pair of the at least one pair of coil windings may be within a preset range.

[0016] In some embodiments, the non-contact coupling apparatus may further include a U-shaped isolation layer. The U-shaped isolation layer may be configured to wrap non-opposing surfaces of each pair of the at least one pair of coil windings.

[0017] In some embodiments, the at least one pair of coil windings may implement the transmission of power and signals in a resonant coupling manner.

[0018] In some embodiments, the at least one pair of coil windings may implement the transmission of power and signals in a non-resonant coupling manner.

[0019] In some embodiments, at least one side of the at least one pair of coil windings may be connected with a resonant circuit. The resonant circuit may be configured to optimize a resonant frequency of the system.

[0020] In some embodiments, a primary coil of the at least one pair of coil windings may be connected with a resonant circuit and a secondary coil of the at least one pair of coil windings may be connected with a resonant circuit.

[0021] In some embodiments, the rotational segment may include a power supply circuit. The power supply circuit may be configured to store power converted from thermal energy of the system. The power may be used to be supplied to one or more auxiliary power devices of the rotational segment.

[0022] In some embodiments, the non-contact coupling apparatus may include at least one capacitive coupling circuit.

[0023] In some embodiments, the non-contact coupling apparatus may further include at least one pair of coil windings.

[0024] In some embodiments, the rotational segment may include a second power line carrier modulation circuit, the stationary segment may include a carrier signal extraction and demodulation circuit. The second power line carrier modulation circuit, the carrier signal extraction and demodulation circuit, and the third coil winding pair may form a data transmission component, and the data transmission component may be configured to transmit scanning data signals and/or feedback signals from the rotational segment to the stationary segment.

[0025] In some embodiments, the non-contact transmission system may further comprise a collaborative control component. The collaborative control component may be configured to monitor and control collaborative operation of associated components across the stationary segment and the rotational segment.

[0026] In some embodiments, the collaborative control component may include: a monitoring circuit of the rotational segment and configured to monitor an operation condition of each element of the rotational segment; and a control circuit of the stationary segment and connected with the monitoring circuit, and configured to control, based on feedback data from the monitoring circuit, the

collaborative operation of the associated modules across the stationary segment and the rotational segment.

[0027] The embodiments of the present disclosure further provide a medical system, comprising a non-contact transmission assembly of the system described in any embodiment of the present disclosure.

[0028] The embodiments of the present disclosure further provide a medical system, comprising: a fixed mechanism; a rotating mechanism, configured to be rotatable relative to the fixed mechanism; an imaging assembly mounted on the rotating mechanism (300) and configured to acquire scanning data signals related with a subject; and a non-contact transmission assembly configured to transmit power to the imaging assembly and transmit the scanning data signals from the imaging assembly to a processor for an image reconstruction in a non-physical contact manner.

[0029] In some embodiments, a first part of the non-contact transmission assembly may be mounted on the fixed mechanism and a second part of the non-contact transmission assembly may be mounted on the rotating mechanism. The transmission of the power and the scanning data signals between the first part and the second part may be implemented in a non-physical contact manner.

[0030] In some embodiments, the non-contact transmission assembly may include at least one pair of coil windings. Each pair of the at least one pair of coil windings may be configured to implement a transmission of at least one of the power and the scanning data signals.

[0031] In some embodiments, each pair of the at least one pair of coil windings may be configured to implement a transmission of different types of information, the different types of information including the power, the scanning data signals, control signals, and feedback signals.

[0032] In some embodiments, each pair of the at least one pair of coil windings may include a primary coil and a secondary coil, the primary coil may be mounted on the fixed mechanism, the secondary coil may be mounted on the rotating mechanism. A space may be provided between the primary coil and the secondary coil, so as to implement the transmission of at least one of the power, the scanning data signals, control signals and feedback signals.

[0033] In some embodiments, the primary coil may be disposed surrounding the fixed mechanism, the secondary coil may be disposed surrounding the rotating mechanism. The fixed mechanism and the rotating mechanism may be coaxially arranged.

[0034] In some embodiments, the at least one pair of coil windings may include one or more pairs of axially-coupled coil windings and/or one or more pairs of radially-coupled coil windings.

BRIEF DESCRIPTION OF THE DRAWINGS

[0035] The present disclosure will be further illustrated by way of exemplary embodiments, which will be described in detail by means of the accompanying drawings. These embodiments are not limiting, and in these embodiments, the same numbering indicates the same structure, wherein:

[0036] FIG. 1A is a schematic diagram illustrating an exemplary process of a transmission of power and signals of a non-contact transmission system according to some embodiments of the present disclosure;

[0037] FIG. 1B is a schematic diagram illustrating an exemplary process of a transmission of

power and signals of a non-contact transmission system according to some embodiments of the present disclosure;

[0038] FIG. 2 is a schematic diagram illustrating an exemplary electrical and electronic structure of a non-contact transmission system according to some embodiments of the present disclosure;

[0039] FIG. 3 is an overall view illustrating an exemplary non-contact transmission system according to some embodiments of the present disclosure;

[0040] FIG. 4 is a cross-sectional oblique view illustrating an exemplary non-contact transmission system according to some embodiments of the present disclosure;

[0041] FIG. 5 is a three-dimensional left view illustrating an exemplary non-contact transmission system according to some embodiments of the present disclosure;

[0042] FIG. 6 is a cross-sectional view illustrating an exemplary non-contact transmission system according to some embodiments of the present disclosure;

[0043] FIG. 7 is a schematic diagram illustrating an exemplary two-dimensional structure of a non-contact transmission system according to some embodiments of the present disclosure;

[0044] FIG. 8 is a cross-sectional front view illustrating an exemplary non-contact transmission system according to some embodiments of the present disclosure;

[0045] FIG. 9A is a schematic diagram illustrating an exemplary process of a transmission of power and signals of a non-contact transmission system according to some embodiments of the present disclosure;

[0046] FIG. 9B is a schematic diagram illustrating an exemplary electrical and electronic structure of a non-contact transmission system according to some embodiments of the present disclosure;

[0047] FIG. 9C is a schematic diagram illustrating another exemplary process of a transmission of power and signals of a non-contact transmission system according to some embodiments of the present disclosure;

[0048] FIG. 9D is a schematic diagram illustrating a further exemplary process of a transmission of power and signals of a non-contact transmission system according to some embodiments of the present disclosure;

[0049] FIG. 9E is a schematic diagram illustrating an exemplary electrical and electronic structure of a non-contact transmission system according to some embodiments of the present disclosure;

[0050] FIG. 9F is a schematic diagram illustrating another exemplary process of a transmission of power and signals of a non-contact transmission system according to some embodiments of the present disclosure;

[0051] FIG. 9G is a schematic diagram illustrating a further exemplary process of a transmission of power and signals of a non-contact transmission system according to some embodiments of the present disclosure;

[0052] FIG. 10A is a schematic diagram illustrating an exemplary electrical and electronic structure of a non-contact transmission system according to some embodiments of the present disclosure;

[0053] FIG. 10B is a schematic diagram illustrating an exemplary process of a transmission of power and signals of a non-contact transmission system according to some embodiments of the present disclosure;

[0054] FIG. 10C is a schematic diagram illustrating another exemplary process of a transmission of power and signals of a non-contact transmission system according to some embodiments of the present disclosure;

[0055] FIG. 11 is a schematic diagram illustrating an exemplary electrical and electronic structure of a non-contact transmission system according to some embodiments of the present disclosure; and

[0056] FIG. 12 is a schematic diagram illustrating an exemplary electrical and electronic structure of a non-contact transmission system according to some embodiments of the present disclosure.

DETAILED DESCRIPTION

[0057] In order to more clearly illustrate the technical solutions of the embodiments of the present disclosure, the accompanying drawings required to be used in the description of the embodiments are briefly described below. Obviously, the accompanying drawings in the following description are only some examples or embodiments of the present disclosure, and it is possible for a person having ordinary skills in the art to apply the present disclosure to other similar scenarios in accordance with these drawings without creative labor. Unless obviously obtained from the context or the context illustrates otherwise, the same numeral in the drawings refers to the same structure or operation.

[0058] It should be understood that "system", "device", "unit" and/or "module" as used herein is a method for distinguishing different components, elements, parts, portions or assemblies of different levels. However, the words may be replaced by other expressions if other words can achieve the same purpose.

[0059] As indicated in the disclosure and claims, the terms "a", "an", and/or "the" are not specific to the singular form and may include the plural form unless the context clearly indicates an exception. Generally speaking, the terms "comprising" and "including" only suggest the inclusion of clearly identified steps and elements, and these steps and elements do not constitute an exclusive list, and the method or device may also contain other steps or elements.

[0060] In the description of this specification, it should be understood that the terms "first", "second", "third", "fourth", etc. are only used for descriptive purposes and should not be understood as indicating or implying relative importance or implicitly indicating the number of the indicated technical features. Therefore, the features defined as "first", "second", "third", and "fourth" may explicitly or implicitly include at least one of the features. In the description of the present disclosure, the meaning of "plurality" is at least two, such as two, three, etc., unless otherwise clearly and specifically defined.

[0061] In the present disclosure, unless otherwise clearly specified and limited, the terms "connection", "fixation", or the like should be understood in a broad sense. For example, the term "connection" may refer to a fixed connection, a detachable connection, or an integral connection; it may refer to a mechanical connection or an electrical connection; it may refer to a direct connection or an indirect connection through an intermediate medium, it may refer to the internal connection of two elements or the interaction relationship between two elements, unless otherwise clearly defined. For those having ordinary skills in the art, the specific meanings of the above terms in the present disclosure can be understood according to the specific circumstances.

[0062] The embodiments of the present disclosure provide a non-contact transmission system, comprising a stationary segment, a rotational segment, and a non-contact coupling apparatus. A primary side of the non-contact coupling apparatus (110) may be connected with the stationary segment (120). A secondary side of the non-contact coupling apparatus (110) may be connected with (e.g., by means of at least one selected from bonding, welding, riveting, and interference fit) the rotational segment (130). For example, the primary side of the non-contact coupling apparatus (110) may be electrically connected with the stationary segment (120), and the secondary side of the non-contact coupling apparatus (110) may be electrically connected with the rotational segment (130). The non-contact coupling apparatus (110) may be configured to implement transmission of power and signals between the stationary segment (120) and the rotational segment (130).

[0063] The stationary segment refers to a module that is disposed on the stationary side of the non-contact transmission system and has a fixed position. For example, the stationary segment may include one or more of an external power supply, a rectifier and filter, an inverter, a DC/DC converter, a power line carrier modulation circuit, a resonant circuit unit, a carrier signal extraction and demodulation circuit, etc., which are disposed on (e.g., by electrical connection) a fixed mechanism (e.g., fixed mechanism 200) or at other fixed positions.

[0064] The rotational segment refers to a module that is disposed on the rotating side of the non-contact transmission system and whose position may change (e.g., rotates with rotation of the rotating gantry). For example, the rotational segment may include one or more of the rectifier and filter, the inverter, a battery module, the power line carrier modulation circuit, etc., disposed on (e.g., by electrical connection) the rotating mechanism (e.g., rotating mechanism 300).

[0065] The non-contact coupling apparatus refers to a non-physical contact structure configured to simultaneously implement transmission of power and signals between the stationary segment and the rotational segment.

[0066] In some embodiments, the non-contact transmission system may be applied to a medical system (e.g., a Computed Tomography (CT) equipment, a Positron Emission Tomography Computed Tomography (PET-CT) equipment, a Single-Photon Emission Computed Tomography (SPET-CT) equipment, or a Radiotherapy equipment). For example, a CT gantry system may use slip rings with the non-contact transmission system (e.g., the non-contact transmission system may be disposed in the slip rings.), thereby simultaneously implementing transmission of power and signals. As another example, the non-contact transmission system may be inserted into a bearing of a gantry of the medical system. For example, the stationary segment and the primary side connected with the stationary segment may be embedded in a stator side of the bearing, and the rotational segment and the secondary side connected with the rotational segment may be embedded in a rotor side of the bearing. In this case, the medical device (e.g., the CT equipment, PET-CT equipment, SPET-CT equipment, or Radiotherapy equipment) may not require the slip ring, reducing the volume of the medical device and avoiding the problem of carbon powder, thereby achieving a high integration of mechanical structure component (e.g., the bearing) and the electrical component (e.g., the non-contact transmission system).

[0067] FIG. 1A is a schematic diagram illustrating an exemplary process of a transmission of

power and signals of a non-contact transmission system according to some embodiments of the present disclosure.

[0068] As shown in FIG. 1A, a non-contact transmission system 100 may include a stationary segment 120 disposed on a fixed mechanism of the system, a rotational segment 130 disposed on a rotating mechanism of the system, and a non-contact coupling apparatus 110 disposed between the stationary segment 120 and the rotational segment 130 and configured to simultaneously implement transmission of power (e.g., first power and/or second power) and signals (e.g., control signals, scanning data signals, and/or feedback signals) between the stationary segment 120 and the rotational segment 130. A primary side of the non-contact coupling apparatus 110 may be connected with (e.g., by electrical connection) the stationary segment 120, and a secondary side of the non-contact coupling apparatus 110 may be connected with (e.g., by electrical connection) the rotational segment 130. In some embodiments, the non-contact coupling apparatus 110 may be configured to implement transmission of power (e.g., first power and/or second power) from the stationary segment 120 to the rotational segment 130. In some embodiments, the non-contact coupling apparatus 110 may be configured to implement an uplink transmission of one or more control signals from the stationary segment 120 to the rotational segment 130. In some embodiments, the non-contact coupling apparatus 110 may be configured to implement a downlink transmission of one or more scanning data signals (e.g., raw image data, processed image data) and/or one or more feedback signals from the rotational segment 130 to the stationary segment 120.

[0069] In some embodiments, at least a portion of the stationary segment 120, the rotational segment 130, and the non-contact coupling apparatus 110 may be disposed in an annular gantry shown in FIG. 1A. For example, the annular gantry shown in FIG. 1A may include a fixed frame and a rotating frame. The fixed gantry may be disposed on a first side (i.e., the stationary side), and the rotating frame may be disposed on a second side (i.e., the rotating side). The stationary segment (e.g., a first rectifier and filter, a first inverter, a DC/DC converter, a second inverter, a first power line carrier modulation circuit, a carrier signal extraction and demodulation circuit, etc.) may be mounted on the fixed gantry, and the rotational segment (e.g., a battery module, a second power line carrier modulation circuit, etc.) may be mounted on the rotating gantry, the primary side of the non-contact coupling apparatus 110 may be disposed on the fixed gantry, the secondary side may be disposed on the rotating gantry, and the primary side and the secondary side may be contactlessly coupled to each other, thereby implementing transmission of power and signals (e.g., transmission of uplink control signals, transmission of downlink scanning data signals, and/or transmission of feedback signals) between the stationary segment and the rotational segment.

[0070] In some embodiments, the non-contact coupling apparatus 110 may include a magnetic coupling (e.g., electromagnetic resonance coupling) structure. Specifically, the non-contact coupling apparatus 110 may include at least one pair of coil windings. The at least one pair of coil windings may include a primary coil and a secondary coil. The primary coil may be used as a primary side of the at least one pair of coil windings, and the secondary coil may be used as a secondary side of the at least one pair of coil windings. The primary coil and the secondary coil may be mutually coupled in a non-physical contact manner. The primary coil and the secondary

coil may be configured to implement transmission of power (e.g., first power and/or second power) and signals (e.g., one or more control signals, one or more scanning data signals, one or more feedback signals, and/or other signals). In some embodiments, the primary side (i.e., the primary coil) and the secondary side (i.e., the secondary coil) of the at least one pair of coil windings may be disposed on the fixed mechanism (e.g., fixed mechanism 200) and the rotating mechanism (e.g., rotating mechanism 300), respectively. The at least one pair of coil windings may be configured to implement the transmission of the power and the signals between the stationary segment and the rotational segment. In some embodiments, at least one side of the at least one pair of coil windings may be connected with a resonant circuit unit. The resonant circuit unit may be configured to optimize a resonant frequency of the system or components thereof (e.g., the primary coil and/or the secondary coil). In some embodiments, the primary coil and the secondary coil of the at least one pair of coil windings may be connected with one resonant circuit unit, respectively.

[0071] In some embodiments, the non-contact coupling apparatus 110 may have a capacitive coupling structure. Specifically, the non-contact coupling apparatus may include at least one capacitive coupling circuit. A primary side (e.g., a first capacitive plate) and a secondary side (e.g., a second capacitive plate) of the capacitive coupling circuit may be disposed on the fixed mechanism and the rotating mechanism, respectively. The at least one capacitive coupling circuit may be configured to implement the transmission of the power (e.g., the first power and/or the second power) and the signals (e.g., the one or more control signals, the one or more scanning data signals, and/or the one or more feedback signals) between the stationary segment and the rotational segment.

[0072] In some embodiments, the non-contact coupling apparatus may be implemented as a combination of various forms of coupling, such as a combination of magnetic coupling and capacitive coupling. For example, the non-contact coupling apparatus 110 may include a pair of coil windings and a capacitive coupling circuit, or a pair of coil windings and two capacitive coupling circuits, or two pairs of coil windings and a capacitive coupling circuit, etc. In some embodiments, the non-contact coupling apparatus may be implemented as other forms of coupling, such as a non-resonant coupling energy transmission form (e.g., a magnetically loosely-coupled form).

[0073] The non-contact transmission system provided in the embodiments of the present disclosure solves a series of defects of carbon brush contact in conventional contact information transmission systems (e.g., a conventional contact slip ring system) by adopting the non-contact coupling apparatus. Accordingly, for signal transmission and power-level transmission of the power, the overall scheme of the mechanical structure and the electrical architecture provided in the embodiments of the present disclosure can, based on the non-contact coupling method (magnetic coupling and/or capacitive coupling) and the voltage carrier method, electrically and mechanically replace the conventional slip ring multi-metal track carbon brush contact method, and reduce the total volume and weight of the rotational segment of the non-contact transmission system, thereby increasing the gantry speed, and achieving transmission of 100 kW (kilowatt) level of electrical power, and achieving better bidirectional data communication performance in the non-physical contact manner at low maintenance cost.

[0074] In some embodiments, the at least one pair of coil windings may include a pair of coil windings. The pair of coil windings may be configured to implement the transmission of the power and the signals between the stationary segment and the rotational segment. For example, the pair of coil windings may be configured to simultaneously implement the transmission of the power (e.g., the first power and/or the second power) from the stationary segment to the rotational segment, the transmission of one or more control signals from the stationary segment to the rotational segment, and/or the transmission of the one or more scanning data signals and/or the one or more feedback signals from the rotational segment to the stationary segment. More descriptions regarding that the at least one pair of coil windings including a pair of coil windings may be found in FIG. 9A and related descriptions thereof.

[0075] In some embodiments, the at least one pair of coil windings may include two pairs of coil windings. One pair of the two pairs of coil windings may be configured to implement the transmission of the power (e.g., the first power and/or the second power) from the stationary segment to the rotational segment; and the other pair of the two pairs of coil windings may be configured to implement the transmission of the one or more scanning data signals and/or the one or more feedback signals from the rotational segment to the stationary segment, and the transmission (e.g., through a manner of voltage carrier communication) of the one or more control signals from the stationary segment to the rotational segment. In some embodiments, one pair of the two pairs of coil windings may be configured to implement the transmission of the power (e.g., the first power and/or the second power) from the stationary segment to the rotational segment, and the transmission of the one or more control signals from the stationary segment to the rotational segment, and the other pair of the two pairs of coil windings may be configured to implement the transmission of the one or more scanning data signals and/or the one or more feedback signals of the rotational segment to the stationary segment. More descriptions regarding the at least one pair of coil windings including two pairs of coil windings may be found in FIG. 9B and related descriptions thereof.

[0076] In some embodiments, the at least one pair of coil windings may include three pairs of coil windings, such as a first coil winding pair, a second coil winding pair, and a third coil winding pair. The first coil winding pair may be configured to implement the transmission of the first power from the stationary segment to the rotational segment to supply power to one or more main power consumption devices (e.g., a radiation source) of the rotational segment; the second coil winding pair may be configured to implement the transmission of the second power from the stationary segment to the rotational segment to supply power to one or more auxiliary power devices (e.g., a battery module, a high voltage generator, etc.) of the rotational segment and the transmission of the one or more control signals from the stationary segment to the rotational segment through voltage carrier communication; and the third coil winding pair may be configured to implement the transmission of the one or more scanning data signals and/or the one or more feedback signals from the rotational segment to the stationary segment. The embodiments of the at least one pair of coil windings including three pairs of coil windings may be found in FIG. 1B-FIG. 8 and related descriptions thereof.

[0077] In some embodiments, the first coil winding pair may be configured to implement the transmission of the power from the stationary segment to the rotational segment to supply power (e.g., the first power) to one or more main power consumption devices (e.g., a radiation source) on the rotational segment and/or supply power (e.g., the second power) to one or more auxiliary power devices (e.g., a battery module, etc.) on the rotational segment; the second coil winding pair may be configured to implement the transmission of the one or more control signals from the stationary segment to the rotational segment through voltage carrier communication; and the third coil winding may be configured to implement the transmission of the one or more scanning data signals and/or the one or more feedback signals from the rotational segment to the stationary segment. For example, the first coil winding pair may be configured to implement the transmission of the first power and the second power from the stationary segment to the rotational segment, simultaneously, so as to supply power to the main power consumption devices and the auxiliary power devices of the rotational segment simultaneously. As another example, the first coil winding pair may be configured to only implement the transmission of the first power from the stationary segment to the rotational segment, so as to supply power the main power consumption device of the rotational segment; at the same time, the auxiliary power devices of the rotational segment may be powered by a power supply circuit disposed at the rotating mechanism. For example, the power supply circuit may collect thermal energy (e.g., thermal energy emitted during operation) generated by modules (e.g., a high voltage generator, the main power consumption devices, etc.) disposed at the rotating mechanism of the non-contact transmission system, and convert the thermal energy into the power to be stored in the power supply circuit. The power supply circuit may be configured to implement the power supply to the auxiliary power devices of the rotational segment by connecting a switching power supply, etc.

[0078] In some embodiments, the first power may be a large-scale power stream (e.g., a power level from kW to 100 kW), the second power may be a small-scale power stream (e.g., a power less than 1 kW), and the first power and the second power may be supplied by the same external power supply (e.g., the first power and the second power may be both supplied by a three-phase external power supply or a 220 V single-phase external power supply) or different external power supplies, respectively (e.g., the first power may be supplied by the three-phase external power supply, and the second power may be supplied by the single-phase external power supply, respectively).

[0079] FIG. 1B is a schematic diagram illustrating an exemplary process of a transmission of power and signals of a non-contact transmission system according to some embodiments of the present disclosure. FIG. 1 B is a schematic diagram illustrating at least one pair of coil windings including three pairs of coil windings.

[0080] As shown in FIG. 1B, at least one pair of coil windings 40 may include a first coil winding pair 41, a second coil winding pair 42, and a third coil winding pair 43. The first coil winding pair 41 may be configured to implement a transmission (also referred to as main power transmission) of first power from a stationary segment to a rotational segment to supply power to the main power consumption devices of the rotational segment. The second coil winding pair 42 may be configured

to implement a transmission (also referred to as auxiliary power transmission) of second power from the stationary segment to the rotational segment and a transmission of one or more control signals from the stationary segment to the rotational segment through voltage carrier communication (also referred to as carrier signal transmission). The second power may be used to supply power to auxiliary power devices of the rotational segment. The third coil winding pair 43 may be configured to implement a transmission of one or more scanning data signals and/or one or more feedback signals of the rotational segment to the stationary segment (also referred to as high-speed data transmission).

[0081] FIG. 2 is a schematic diagram illustrating an exemplary electrical and electronic structure of a non-contact transmission system according to some embodiments of the present disclosure. The electrical and electronic structure of the non-contact transmission system may be described by taking at least one pair of coil windings including three pairs of coil windings in FIG. 2 as an example. In some embodiments, a portion of the rotational segment, a portion of the stationary segment, and the first coil winding pair may form a main power transmission component 1. According to FIG. 1 and FIG. 2, the non-contact transmission system 100 may include an external power supply 16 and the main power transmission component 1. The external power supply 16 may be configured to provide power (e.g., first power). The main power transmission component 1 may be configured to implement a transmission of the first power. In some embodiments, the main power transmission component 1 may be configured to implement the transmission of the first power (e.g., a transmission of 10-100 kW power) from a stationary segment to a rotational segment of the system based on an electromagnetic resonant coupling technology to supply power to one or more components of the rotational segment (e.g., to provide the first power to a radiation source). For example, the main power transmission component 1 may be configured to implement the transmission of the first power from the stationary segment to the rotational segment of the system through the first coil winding pair 41 (e.g., a winding coupler (i.e., #1 EM coupler) shown in FIG. 2) based on the electromagnetic resonant coupling technology.

[0082] In some embodiments, the stationary segment may include a high-frequency AC voltage output circuit 11, and the rotational segment may include a main power output circuit 13. In some embodiments, as shown in FIG. 2, the main power transmission component 1 may include the high-frequency AC voltage output circuit 11 of the stationary segment, a main power output circuit 13 of the rotational segment, and the first coil winding pair 41. The high-frequency AC voltage output circuit 11 may be respectively connected with the external power supply 16 and a first primary coil of the first coil winding pair 41 disposed on the fixed mechanism (e.g., fixed mechanism 200) and configured to output a high-frequency AC voltage. The main power output circuit 13 may be respectively connected with a first secondary coil of the first coil winding pair 41 disposed on the rotating mechanism (e.g., rotating mechanism 300) and the main power consumption device 02 disposed on the rotating mechanism and configured to supply power to the main power consumption device 02 (e.g., the radiation source).

[0083] In some embodiments, as shown in FIG. 2, the high-frequency AC voltage output circuit 11 may include an isolation transformer 111, a first rectifier and filter 112, and a first inverter 113

connected in sequence. The isolation transformer 111 may be configured to implement circuit isolation. The first rectifier and filter 112 may be configured to implement rectification and filtering, for example, to convert an AC voltage into a DC voltage and filter a residual AC voltage in a rectified DC voltage. The first inverter 113 may be configured to convert the DC voltage into the AC voltage.

[0084] In some embodiments, as shown in FIG. 2, the external power supply 16 may be a three-phase external power supply. A 380 V AC voltage provided by the external power supply 16 may pass through the first rectifier and filter 112 via the isolation transformer 111, to the first inverter 113 (e.g., a high-frequency inverter) through a DC bus to output a high-frequency AC voltage. In some embodiments, a set of power semiconductor switch components used in the first inverter 113 may include, but are not limited to, a metal oxide semiconductor field effect transistor (MOSFET) or an insulated gate bipolar transistor (IGBT) that is fabricated based on silicon-based Si, silicon carbide (SiC), and/or gallium nitride (GaN). A gate of the switch device in the first inverter 113 may be controlled by a pulse width modulation (PWM) drive circuit controller 14 to provide a high-frequency AC (including but not limited to sinusoidal AC or high-frequency pulse signal, etc.) output within a preset frequency range. In addition, the non-contact transmission system in the embodiments of the present disclosure may use a conventional industrial three-phase power grid to supply power to the main power consumption equipment. Alternatively or additionally, the non-contact transmission system may realize an improved design by additionally arranging a power conversion module and an energy storage module on the rotational segment of the system to receive external power supply of ordinary 220 V AC single-phase mains. For example, the external power supply 16 may be a single-phase external power supply, providing a 220 V AC voltage (e.g., through a 220 V AC external power supply shown in FIG. 2 or another 220 V AC external power supply). In this case, in order to ensure high energy power supply of the main power transmission component 1, an energy storage component (e.g., a battery module) may be additionally arranged between the first rectifier and filter 112 and the first inverter 113, thereby solving the problem of insufficient power capacity of a single-phase external power supply, and ensuring the energy supply demand.

[0085] In some embodiments, as shown in FIG. 2, the main power output circuit 13 may include a second rectifier and filter 131 and a fourth inverter 132 (e.g., an inverter with high voltage tank) connected in sequence. The second rectifier and filter 131 may be connected with a first secondary coil of a first coil winding pair for rectification and filtering. For example, an AC voltage transmitted from the first secondary coil of the first coil winding pair 41 connected with the rotational segment may be converted into a DC voltage, and a residual AC voltage in a rectified DC voltage may be filtered out. In some embodiments, the second rectifier and filter 131 may be directly connected with the first secondary coil of the first coil winding pair. In some embodiments, the second rectifier and filter 131 may be indirectly connected with the first secondary coil of the first coil winding pair. For example, the second rectifier and filter 131 may be connected with the first secondary coil through a second resonant circuit 15 described below. The fourth inverter 132 may be connected with the main power consumption device 02 for converting the DC voltage into high-voltage AC power and supplying the high-voltage AC power to the main power consumption device 02 (e.g., an X-ray tube). In the embodiments of the present disclosure, AC refers to alternating current, and DC

refers to direct current.

[0086] In some embodiments, the stationary segment 120 may further include a drive circuit controller 14. In some embodiments, the main power transmission component 1 may further include the drive circuit controller 14 disposed on the fixed mechanism (e.g., fixed mechanism 200). The drive circuit controller 14 may be configured to control a set of power semiconductor switch components of the first inverter 113 to adjust a real-time output voltage of the high-frequency AC voltage output circuit 11. In some embodiments, the drive circuit controller 14 may implement control of a resonant frequency of the first primary coil. A control scheme of the drive circuit controller implementing control the resonant frequency of the first primary coil may be described below.

[0087] According to the description above, at least one side of at least one pair of coil windings may be connected with a resonant circuit unit. In some embodiments, as shown in FIG. 2, the main power transmission component 1 may further include a first resonant circuit 12. The first resonant circuit 12 may be electrically connected with the high-frequency AC voltage output circuit 11 and the first primary coil of the first coil winding pair 41, respectively, to configure a resonant frequency of the first primary coil of the first coil winding pair 41 to optimize a power level and efficiency of the non-contact power transmission.

[0088] In some embodiments, the first resonant circuit 12 may include an adjustable coupling capacitor 121 and an adjustable coupling inductor 122. The adjustable coupling capacitor 121 and the adjustable coupling inductor 122 may be electrically connected with the high-frequency AC voltage output circuit 11 and different electrodes of the first primary coil of the first coil winding pair 41, respectively. For example, the adjustable coupling capacitor 121 may be connected with a first electrode (e.g., a positive electrode, shown as "+" in FIG. 2) of the first primary coil, and the adjustable coupling inductor 122 may be connected with a second electrode (e.g., a negative electrode, shown as "-" in FIG. 2) of the first primary coil. By adjusting an inductance value of the adjustable coupling inductor 122 and/or a capacitance value of the adjustable coupling capacitor 121, the resonant frequency of the first primary coil of the first coil winding pair 41 may be configured.

[0089] In some embodiments, as shown in FIG. 2, an LC configuration of the first resonant circuit 12 may be a series configuration. In some embodiments, the LC configuration of the first resonant circuit 12 may be in another form.

[0090] In some embodiments, the resonant frequency of a coil winding (i.e., the first primary coil) of the first coil winding pair 41 disposed on the fixed mechanism may be configured according to Equation (1):

$$f = \frac{1}{2\pi\sqrt{LC}}, \quad (1)$$

wherein, f denotes the resonant frequency, L denotes a sum of the inductance value of the adjustable coupled inductor and an inductance value of the primary coil, and C denotes the capacitance value of the adjustable coupling capacitor. A desired optimized resonant frequency may be achieved by measuring an actual inductance value of the primary coil and configuring an inductance value of inductor $Lr1$ and a capacitance value of capacitor $Cr1$.

[0091] In some embodiments, a real-time inductance value of the first primary coil may be monitored by a sensor (not shown in the figure), and the resonant frequency of the first primary coil may be obtained based on the inductance value of the inductor Lr1 and the capacitance value of the capacitor Cr1 of the first resonant circuit unit 12 according to Equation (1).

[0092] In some embodiments, the non-contact transmission system may have a target resonant frequency range. The target resonant frequency range refers to a frequency range suitable for operation of the non-contact transmission system. In some embodiments, the target resonant frequency range may be within a range of 10 kHz-500 kHz. In some embodiments, when the non-contact transmission system is operating, an initial target resonant frequency range may be preset. The initial target resonant frequency range may be a sub-range in the target resonant frequency range. For example, the initial target resonant frequency range may be within a range of 200 kHz-450 kHz. As another example, the target resonant frequency range may be within a range of 100 kHz-175 kHz.

[0093] In some embodiments, if the obtained resonant frequency of the first primary coil is within the initial target resonant frequency range, a frequency parameter of the drive circuit controller 14 may be set to an operating frequency value using a control circuit (see below) of a cooperative control module. The operating frequency value refers to the resonant frequency value of the first primary coil obtained according to Equation (1).

[0094] In some embodiments, if the resonant frequency value of the first primary coil is not within the initial target resonant frequency range, the inductance value of Lr1 and/or the capacitance value of Cr1 in the first resonant circuit unit 12 may be adjusted, such that the resonant frequency value of the first primary coil recalculated based on an adjusted inductance value of Lr1 and/or capacitance value of Cr1 and the inductance value of the primary coil may be within the initial target resonant frequency range. In some embodiments, if the resonant frequency value is still not within the initial target resonant frequency range by adjusting the inductance value of Lr1 and/or the capacitance value of Cr1, the initial target resonant frequency range may be switched. For example, a first initial target resonant frequency range may be switched to a second initial target resonant frequency range. The first initial target resonant frequency range and the second initial target resonant frequency range may be both within the target resonant frequency range. The second initial target resonant frequency range may be greater than or less than the first initial target resonant frequency range.

[0095] Through the above adjustment, the operating frequency F may be close to a natural resonant frequency f. For example, when the operating frequency F is within a range of 10 k-40 kHz, an inductance value L may be within a range of 2-5 mH, and a capacitance value C may be within a range of 5-100 nF; when F is within a range of 100 k-200 kHz, L may be within a range of 5-500 uF, and C may be within a range of 5-200 nF; when F is an optimal value of 150 kHz, C may be set to 200 nF, and L may be set to 5.63 uH.

[0096] According to the description above, the primary coil and the secondary coil of the coil winding pair may be connected with the resonant circuit, respectively. As shown in FIG. 2, in some embodiments, the main power transmission component 1 may further include a second resonant

circuit 15. The second resonant circuit 15 may be disposed on the rotating mechanism (e.g., rotating mechanism 300) and electrically connected with the main power output circuit 13 and the first secondary coil of the first coil winding pair 41, respectively. In some embodiments, capacitors of the first resonant circuit 12 and the second resonant circuit 15 may be connected in series and parallel in a compensation topology. Specifically, when optimization of the transmission efficiency is considered, a resonant capacitor of the resonant circuit (e.g., the first resonant circuit 12 and/or the second resonant circuit 15) may be regarded as a power factor compensation capacitor (PFC compensation capacitor) of a coupling mechanism of the non-contact transmission system. If the resonant circuit is used on both the primary coil and the secondary coil of the at least one pair of coil windings, the capacitor of each unit may be designed with compensation topologies such as primary series-secondary series (SS), primary series-secondary parallel (SP), primary parallel-secondary series (PS), primary parallel-secondary parallel (PP), etc.

[0097] Similar to the configuration of the resonant frequency of the first primary coil using the first resonant circuit 12, for the first secondary coil, a resonant frequency of a second secondary coil may be configured using the second resonant circuit 15 according to Equation (1). For example, a real-time inductance value of the second secondary coil may be monitored using the sensor, and a resonant frequency value of the second secondary coil may be obtained based on a capacitance value of capacitor C2 of the second resonant circuit 15 according to Equation (1).

[0098] In some embodiments, the first primary coil and the first secondary coil of the first coil winding pair may be optimized based on an operating frequency feasibility according to Equation (1). If an optimized configuration value of the resonant frequency of the first primary coil approaches or is equal to an inherent or configured resonant frequency of the first secondary coil, the main power transmission component 1 may realize an operating state of electromagnetic resonance coupling. In this state, the power transmission of the non-contact transmission system may be optimum from the perspective of power level and efficiency. An induced voltage and an induced current induced by the electromagnetic resonance coupling may be transmitted through the second rectifier and filter 131 and the fourth inverter 132 on the first secondary coil side to realize the transmission of the power (e.g., 10-100 kW power) from the stationary segment to the rotational segment to supply power to components of the rotational segment (e.g., to supply the first power to the main power consumption device 02).

[0099] In some embodiments, if the main power transmission component 1 includes the first resonant circuit 12 and the second resonant circuit 15, the inductance and/or the capacitance value of the first resonant circuit 12 and the second resonant circuit 15 may be adjusted first, such that resonant frequencies of the first primary coil and the first secondary coil may be equal or substantially equal. When the resonant frequencies of the first primary coil and the first secondary coil are equal or substantially equal, and both are within the initial target resonant frequency range, the frequency parameter of the drive circuit controller 14 may be set to the operating frequency value by using the control circuit (see below) of the cooperative control module.

[0100] In some embodiments, when the resonant frequencies of the first primary coil and the first secondary coil are equal or substantially equal but are not within the initial target resonant frequency

range, the initial target resonant frequency range may be switched, such that the resonant frequencies of the first primary coil and the first secondary coil may be within the switched initial target resonant frequency range.

[0101] It should be noted that, in some embodiments, the main power transmission component 1 may include only one resonant circuit, such as only one of the first resonant circuit 12 and the second resonant circuit 15. In some embodiments, the main power transmission component 1 may include both the first resonant circuit 12 and the second resonant circuit 15.

[0102] In some embodiments, the resonant frequencies of the primary side and the secondary side of the at least one pair of coil windings may be adjusted using the resonant circuit before the system operates. In some embodiments, the resonant frequencies of the primary side and the secondary side of the at least one pair of coil windings may be adjusted in real time using the resonant circuit.

[0103] Merely by way of example, after the resonant frequency of the at least one pair of coil windings is adjusted, a 380 V AC voltage provided by the external power supply 16 may pass through the isolation transformer 111 through the first rectifier and filter 112, to the first inverter 113 through a DC bus to output a high-frequency AC voltage. After the high-frequency AC voltage is transmitted to the first primary coil of the first coil winding pair 41 connected with the stationary segment, the high-frequency AC voltage may be transmitted to the first secondary coil connected with the rotational segment through electromagnetic coupling. The high-frequency AC voltage output by the first secondary coil may pass through the fourth inverter 132 through the second rectifier and filter, and may be provided to the main power consumption device 02.

[0104] In some embodiments, a portion of the stationary segment, a portion of a rotational segment, and the second coil winding pair may form an auxiliary power with carrier signal transmission component 2. In some embodiments, as shown in FIG. 1 or FIG. 2, the non-contact transmission system 100 may further include the auxiliary power with carrier signal transmission component 2. The auxiliary power with carrier signal transmission component 2 may be configured to implement a transmission of power (e.g., the second power) and one or more carrier signals (e.g., one or more uplink control signals of the system) from the stationary segment to the rotational segment of the system through the second coil winding pair 42 based on a power line carrier technology. In some embodiments, the second power and the one or more carrier signals may be transmitted synchronously or asynchronously.

[0105] In some embodiments, the stationary segment 120 may further include a first power line carrier modulation circuit, a DC/DC converter, and a second inverter, the rotational segment 130 may further include a carrier signal extraction and envelope detection demodulation circuit. In some embodiments, as shown in FIG. 2, the auxiliary power with carrier signal transmission component 2 may include a first power line carrier modulation circuit 21, a DC/DC converter 22, and a second inverter 23 disposed on the fixed mechanism (e.g., fixed mechanism 200), a carrier signal extraction and envelope detection demodulation circuit 25 disposed on the rotating mechanism (e.g., rotating mechanism 300), and second coil winding pair 42. The first power line carrier modulation circuit 21 may be configured to control an output voltage of the DC/DC converter 22 based on one or more control signals on the stationary segment such that the output voltage has an amplitude

envelope feature. The amplitude envelope feature may be configured to characterize information of the one or more control signals. The output voltage of the DC/DC converter 22 may be transmitted to a second secondary coil of the second coil winding pair 42 connected with the rotational segment through a second primary coil of the second coil winding connected with the stationary segment. The carrier signal extraction and envelope detection demodulation circuit 25 may be configured to extract an envelope from a voltage carrier of the second secondary coil and demodulate the envelope into a digital signal (a digital signal corresponding to the one or more control signals).

[0106] In this embodiment, a single-phase 220 V AC voltage may be accessed through an ordinary municipal power grid, and a DC/DC converter (e.g., the DC/DC converter 22) may be set after a third rectifier and filter 26. The converter unit may be controlled by a power line carrier modulation module (e.g., the first power line carrier modulation circuit 21). As shown in FIG. 2, a power supply of the auxiliary power with carrier signal transmission component 2 may be a 220 V AC single-phase external power supply. A 220 V AC voltage provided by the external power supply may pass through the DC/DC converter 22 through the third rectifier and filter 26, and may be connected with the second inverter 23 to output a high-frequency AC voltage (the second power). In some embodiments, the power supply of the auxiliary power with carrier signal transmission component 2 may use an ordinary 220 V AC single-phase external power supply. In this case, the external power supply of the auxiliary power with carrier signal transmission component 2 and the external power supply of the main power transmission component 1 may share a single-phase external power supply. Alternatively, the external power supply of the auxiliary power with carrier signal transmission component 2 and the external power supply of the main power transmission component 1 may use a single-phase external power supply, respectively. In some embodiments, the external power supply of the auxiliary power with carrier signal transmission component 2 may also be set to be able to extract one phase from three-phase grid (e.g., the external power supply 16 shown in FIG. 2) of the main power transmission component 1 (before passing through the isolation transformer), thereby reducing the site configuration requirements of one power input port/socket. In some embodiments, the external power supply of the auxiliary power with carrier signal transmission component 2 may be implemented by solar energy, a battery module, etc. For example, the auxiliary power with carrier signal transmission component 2 may be configured to transmit energy of a solar panel or the battery module disposed at the fixed mechanism (e.g., fixed mechanism 200) from the stationary segment to the rotational segment of the system through the second coil winding pair 42 to supply power to the auxiliary power devices disposed at the rotating mechanism (e.g., rotating mechanism 300).

[0107] In combination with the above, in some embodiments, the auxiliary power with carrier signal transmission component 2 may only implement the transmission of the one or more control signals. In this case, the auxiliary power devices may be powered by the first coil winding pair (e.g., the first coil winding pair may implement the transmission of the first power and the second power from the stationary segment to the rotational segment simultaneously realizes), or powered by the power supply circuit of the rotational segment. In some embodiments, the non-contact transmission system 100 may further include the power supply circuit (not shown in the figure) disposed at the

rotating mechanism (e.g., rotating mechanism 300). The power supply circuit may be configured to store power converted from thermal energy of the system 100, and the power may be used to be supplied to the one or more auxiliary power devices disposed at the rotating mechanism (e.g., rotating mechanism 300). For example, the power supply circuit may collect the thermal energy (e.g., the thermal energy emitted during operation) generated by the modules (e.g., the high voltage generator, the main power consumption devices, etc.) disposed at the rotating mechanism (e.g., rotating mechanism 300) of the non-contact transmission system 100, and convert the thermal energy into the power to be stored in the power supply circuit. The power supply circuit may implement the power supply to the auxiliary power devices disposed at the rotating mechanism (e.g., rotating mechanism 300) by connecting a switching power supply, etc.

[0108] In some embodiments, the first power line carrier modulation circuit 21 may be designed as a module based on amplitude modulation and configured to modulate a baseband digital signal (including but not limited to the one or more uplink control signals of the system) by binary amplitude shift keying (2ASK) modulation and implement digital signal processing (DSP), and then a control circuit 211 may quickly control and change the voltage output of the DC/DC converter 22. In this case, a DC voltage output may be used as a DC voltage input of a high-frequency inverter (e.g., the second inverter 23) and carry a modulated digital signal. Accordingly, an input voltage of the second inverter 23 may be fundamentally enabled to have the amplitude envelope feature. The amplitude envelope feature may include information of the baseband digital signal.

[0109] After the voltage carrying the modulated signal (i.e., the voltage with the amplitude envelope feature) synchronously transmits the second power and the one or more control signals to the rotational segment (i.e., after the second coil winding pair 42) through electromagnetic induction resonant coupling, the auxiliary power with carrier signal transmission component 2 may be designed with the carrier signal extraction and envelope detection demodulation circuit 25 after a second secondary coil end of the second coil winding pair. The carrier signal extraction and envelope detection demodulation circuit 25 may include an amplitude demodulator or an envelope detection circuit and may be configured to extract and demodulate a voltage with the amplitude envelope feature, so as to restore the baseband digital signal, i.e., to implement the transmission of non-contact electromagnetic resonance coupling of the data/signal carrier on a voltage waveform.

[0110] In some embodiments, the carrier signal extraction and envelope detection demodulation circuit 25 may include a diode, a capacitor C3, a resistor R3, an inductor L2, a bandpass filter circuit 251, a half-wave rectifier circuit 252, a low-pass filter circuit 253, a timing pulse reference voltage signal 254, and a comparator IC. Circuit connection of C3, L2 and R3 may not be limited to a series or parallel mode. In some embodiments, the operating principle of the circuit may be similar to the operating principle of the first resonant circuit 12 and the second resonant circuit 15 mentioned above. A resonant frequency of a circuit composed of the C3, L2 and R3 circuit and the second coil winding pair 42 may correspond to the optimized resonant frequency of the second secondary coil. Since the auxiliary power with carrier signal transmission component 2 operates at the optimal resonant frequency, the carrier signal extraction and envelope detection demodulation circuit 25 may effectively extract the carrier signal and restore the carrier signal to the baseband

digital signal.

[0111] In some embodiments, all loads (e.g., an anode drive, kV-mA control, battery module, etc.) of auxiliary power sub-components of the rotational segment of the system may be regarded as a whole, and power conversion modes thereof (e.g., AC/DC rectification and DC/AC inversion) are not discussed in this embodiment. The power (i.e., the second power used to be supplied to each auxiliary power sub-component on the rotational segment) requirements of all the loads of the auxiliary power sub-components of the rotational segment of the system may be satisfied in a non-contact manner through electromagnetic resonance coupling.

[0112] In some embodiments, the auxiliary power with carrier signal transmission component 2 may further include a third resonant circuit 24. The third resonant circuit 24 may be configured to configure a resonant frequency of the second primary coil connected with a stationary segment of the second coil winding pair 42, to optimize the power level and efficiency of the non-contact transmission system. The mode of optimizing the power level and efficiency of the auxiliary power with carrier signal transmission component 2 by configuring the resonant frequency of the second primary coil using the third resonant circuit 24 and configuring the resonant frequency of the second secondary coil using the circuit including a capacitor C3, an inductor L2, and a resistor R3 in the carrier signal extraction and envelope detection demodulation circuit 25 may be similar to the optimization mode of the resonant frequency of the first coil winding corresponding to the main power transmission component 1 described above, which is not repeated here. It should be noted that in some embodiments, the auxiliary power with carrier signal transmission component 2 may not include the third resonant circuit 24.

[0113] In some embodiments, a portion of the rotational segment, a portion of the stationary segment, and the third coil winding pair 43 may form a data transmission component 3. In some embodiments, the portion of the rotational segment 130 may include a battery module 31, a second power line carrier modulation circuit 32, a fourth resonant circuit 33, a third inverter 34, and power amplifier 35. In some embodiments, the portion of the stationary segment 120 may include a carrier signal extraction and demodulation circuit 36. In some embodiments, as shown in FIG. 1 or FIG. 2, the non-contact transmission system 100 may further include the data transmission component 3. The data transmission component 3 may be configured to transmit scanning data signals and/or feedback signals from the rotational segment to the stationary segment through the non-contact coupling apparatus. As shown in FIG. 1, the data transmission component 3 may use the third coil winding pair 43 to downlink-transmit the scanning data signals (e.g., the raw image data, and/or processed image data) and/or the feedback signals from the rotational segment to the stationary segment based on the principle of electromagnetic induction loose coupling. In some embodiments, the data transmission component 3 may include the battery module 31, the second power line carrier modulation circuit 32, the fourth resonant circuit 33, the third inverter 34, the power amplifier 35, and the carrier signal extraction and demodulation circuit 36 disposed on the fixed mechanism (e.g., fixed mechanism 200).

[0114] The second power line carrier modulation circuit 32 may be configured to modulate the scanning data signals and/or the feedback signals on the rotational segment according to preset

spectrum point requirements, and control an operating frequency of the third inverter 34 based on spectrum points to load the scanning data signals and/or feedback signals into a voltage waveform of a third secondary coil of the third coil winding pair 43 disposed on the rotating mechanism (e.g., rotating mechanism 300).

[0115] The fourth resonant circuit 33 may be configured to set the resonant frequency of the third primary coil of the third coil winding pair 43 disposed on the fixed mechanism (e.g., fixed mechanism 200) based on the operating frequency of the third inverter 34, to optimize the efficiency of the non-contact transmission system. The fourth resonant circuit 33 may set the resonant frequency of the third primary coil in the same manner as the first resonant circuit 12 set the resonant frequency of the first primary coil, which is not repeated here.

[0116] The carrier signal extraction and demodulation circuit 36 may be configured to extract a carrier signal from the voltage waveform of the third primary coil of the third coil winding pair 43 disposed on the fixed mechanism (e.g., fixed mechanism 200) based on the operating frequency and demodulate the carrier signal into the digital signal.

[0117] By providing a modulation module (e.g., the second power line carrier modulation circuit 32) and a demodulation module (e.g., the carrier signal extraction and demodulation circuit 36) in the data transmission component 3, the accuracy of data and/or signal transmission from the rotational segment to the stationary segment may be improved.

[0118] In some embodiments, a modulation mode of the first power line carrier modulation circuit 21 of the auxiliary power with carrier signal transmission component 2 and a modulation mode of the second power line carrier modulation circuit 32 of the data transmission component 3 may be the same. Specifically, an implementation mode of data synchronization transmission is to apply a voltage carrier to the auxiliary power with carrier signal transmission component 2 and the data transmission component 3. A digital modulation mode of the voltage carrier may include but is not limited to amplitude shift keying (ASK), frequency shift keying (FSK), phase shift keying (PSK) or quadrature amplitude modulation (QAM), etc. The specific applicable modulation mode may be selected according to the specific requirements for total power transmission power and total transmission efficiency. For example, considering that the implementation of ordinary ASK modulation is relatively simple, the anti-interference ability is relatively weak when the amplitude is not high. FSK has a strong anti-interference ability, but a change in a carrier frequency may affect a resonant state of a circuit and thus affect the total power transmission power and efficiency of the system. In the application scenario of high anti-interference ability requirements, low transmission bit error rate requirements, and other performance requirements, the specific applicable modulation mode may also adopt an improved or hybrid derivative modulation design to increase a modulation depth, so as to ultimately ensure the requirements of high-performance power and data transmission. Preferably, the first power line carrier modulation circuit 21 may use a 2ASK modulation mode, and the second power line carrier modulation circuit 32 may use a 2FSK or QAM modulation mode.

[0119] In some embodiments, the battery module 31 may be used as an energy storage component (or one of energy storage components) of the entire system and configured to obtain the

second power supplied by the auxiliary power with carrier signal transmission component 2 and may be configured to timely supply power to the data transmission component 3 under the supervision and control of a battery management system (BMS) and a collaborative control component (e.g., a collaborative control component 37 below) disposed on the rotating mechanism (e.g., rotating mechanism 300). In addition, an external power supply of the data transmission component 3 may include but is not limited to a battery module (e.g., the battery module 31), and may also use an uninterrupted external power supply (UPS) or use direct power from a load end of the auxiliary power with carrier signal transmission component 2. If the battery module is used, a battery type may include but is not limited to an energy density battery (e.g., a lithium-ion battery, a sodium ion battery, etc.), and/or a power density battery (e.g., a supercapacitor, etc.).

[0120] After a DC voltage output from the battery module 31 passes through a filtering electrolytic capacitor, the third inverter 34 and the power amplifier 35 may implement, under the control of the second power line carrier modulation circuit 32, non-contact downlink data transmission of a high data volume baseband digital signal (especially the scanning data signals and/or a portion of the feedback signals) of the rotational segment of the system to the stationary segment of the system through an appropriate carrier modulation mode and electromagnetic induction loose coupling.

[0121] In some embodiments, the second power line carrier modulation circuit 32 may be designed to use a mode of frequency modulation and resonance. Specifically, high data volume baseband digital signals (e.g., the scanning data signals and/or the feedback signals) of the rotational segment of the system may be modulated by binary frequency shift keying (2FSK) to transmit requirements of preset two preferred operating spectrum points (i.e., a resonant frequency $Fr1$ and an operating frequency $Fr2$ in a non-resonant loose coupling state) to a digital signal processing chip (DSP) (or an STM32 chip, an FPGA, etc.), and the DSP may be responsible for processing the baseband digital signal and controlling a drive circuit 321, to control an opening and closing rate of a gate of a set of power semiconductor switching device components (e.g., an IGBT, an MOSFET, etc.) of a high-frequency inverter, and achieve operating frequencies $Fr1$ and $Fr2$ output by the third inverter 34, thereby loading the high data volume baseband digital signals (e.g., '1' corresponds to $Fr1$, and '0' corresponds to $Fr2$) of the rotational segment of the system (e.g., the medical system) to a voltage waveform of the third coil winding (e.g., the winding coupler #3 EM in FIG. 2) of the rotational segment.

[0122] Based on electromagnetic resonance coupling (corresponding to $Fr1$) and electromagnetic induction loose coupling (corresponding to $Fr2$), power line carrier signals may be amplified by the power amplifier 35 and coupled by the fourth resonant circuit 33, and then downlink transmitted to the stationary segment of the system.

[0123] In some embodiments, the carrier signal extraction and demodulation unit 36 may include two parallel resonant demodulation circuits. The resonant frequencies of the two resonant demodulation circuits may be configured as $Fr1$ and $Fr2$, respectively, to use the resonance effect of the two resonant demodulation circuits to extract a carrier signal with a frequency $Fr1$ and a carrier signal with a frequency $Fr2$, respectively. After the two carrier signals are extracted, demodulation may be implemented by performing comparison of voltage amplitudes through a voltage comparator,

thereby restoring original baseband digital signals (e.g., the scanning data signals, the feedback signals, etc.).

[0124] In some embodiments, a ratio of a count of turns of the primary coil to the secondary coil of the at least one pair of coil windings may affect resonant frequency points of the two coils and the transmission efficiency of magnetic coupling. In some embodiments, in order to meet the requirements of the resonant frequency and the transmission efficiency, a ratio of winding turns of the first primary coil to the first secondary coil of the first coil winding pair may be 1:1.5; a ratio of winding turns of the second primary coil to the second secondary coil of the second coil winding pair may be 1:1.5; and a ratio winding turns of the third primary coil to the third secondary coil of the third coil winding pair may be 1:1. In some embodiments, at least two of the first ratio, the second ratio, and the third ratio may be denoted as the same or different values, respectively. For example, both of the first ratio and the second ratio may be 1: 1.5, and the third ratio may be 1: 1. As another example, the first ratio may be 1: 1, the second ratio may be 1: 1.5, and the third ratio may be 1: 1.

[0125] In some embodiments, in order to meet the requirements of the resonant frequency and the transmission efficiency, the count of turns of the first primary coil and the count of turns of the first secondary coil of the first coil winding pair may be the same; the count of turns of the second primary coil and the count of turns of the second secondary coil of the second coil winding pair may be the same; and the count of turns of the third primary coil and the count of turns of the third secondary coil of the third coil winding pair may be different.

[0126] By setting the ratio of the count of turns of the primary coil to that of the secondary coil of the at least one pair of coil windings, the resonant frequency can be more in line with the requirements, and the transmission efficiency can be improved.

[0127] In some embodiments, the first coil winding pair 41 may be set away from the second coil winding pair 42 and the third coil winding pair 43. Since the first coil winding pair 41 performs high-power transmission, such configuration may avoid electromagnetic interference between the first coil winding pair 41 and the second coil winding pair 42 and between the first coil winding pair 41 and the third coil winding pair 43. For example, the electromagnetic compatibility (EMC) impact (e.g., signal coupling crosstalk, etc.) of a medium-frequency high-voltage and high-power electromagnetic field (e.g., 100 k-150 kHz, 100 kW main power) on a relatively low-frequency and low-power electromagnetic field (e.g., 10 k-40 kHz, several kW auxiliary power carrier) and a high-frequency and low-power signal electromagnetic field (e.g., 100 MHz-GHz high-speed data downlink communication transmission) may be avoided. A medium frequency may be within a range of 100 kHz-500 kHz. Optionally, the medium frequency may be within a range of 100 k-150 kHz.

[0128] In some embodiments, the primary coil and the secondary coil of the at least one pair of coil windings may be radially opposite or axially opposite (e.g., in an axial direction of a CT gantry or in a radial direction perpendicular to an axis). Being axially opposite means that the primary coil and the secondary coil are coaxial (i.e., an axis of the primary coil may coincide with an axis of the secondary coil) and disposed at intervals in an axial direction. Being radially opposite means that the primary coil and the secondary coil are coaxial and disposed at intervals from inside to outside in a radial direction (e.g., the primary coil and the secondary coil may be disposed at an inner ring and

an outer ring of the gantry, respectively). In some embodiments, the at least one pair of coil windings may include one or more pairs of axially-coupled coil windings, and/or one or more pairs of radially-coupled coil windings.

[0129] In some embodiments, a relative arrangement of the primary coil and the secondary coil of each pair of the at least one pair of coil windings may be the same. For example, if the at least one pair of coil windings include the first coil winding pair 41, the second coil winding pair 42, and the third coil winding pair 43, primary coils and secondary coils of the first coil winding pair 41, the second coil winding pair 42, and the third coil winding pair 43 may all be radially opposite. As another example, if the at least one pair of coil windings include the first coil winding pair 41, the second coil winding pair 42, and the third coil winding pair 43, the primary coil and the secondary coil of the first coil winding pair 41, the second coil winding pair 42, and the third coil winding pair 43 may all be axially opposite.

[0130] In some embodiments, the relative arrangement of the primary coil and the secondary coil of each pair of the at least one pair of coil windings may be different. For example, if the at least one pair of coil windings include the first coil winding pair 41, the second coil winding pair 42, and the third coil winding pair 43, primary coils and secondary coils of the first coil winding pair 41, the first primary coil and the first secondary coil of the first coil winding pair 41 may be axially opposite, the second primary coil and the second secondary coil of the second coil winding pair 42 may be radially opposite, and the third primary coil and the third secondary coil of the third coil winding pair 43 may be radially opposite.

[0131] Taking the three pairs of coil windings in FIG. 2 as an example, the first coil winding pair 41 may include a pair of axially opposite winding coils with the same count of turns; the second coil winding pair 42 may include a pair of radially opposite winding coils with the same count of turns; the third coil winding pair 43 may include a pair of radially opposite winding coils with different count of turns; and the first coil winding pair 41 may be disposed away from the second coil winding pair 42 and the third coil winding pair 43 within the mechanical structure of the coupling module.

[0132] By setting the at least one pair of coil windings as the combination of axial coupling and radial coupling, the first coil winding pair can be set away from other coil winding pairs (e.g., the first distance between the first coil winding part 41 and the second coil winding part 42 may be greater than the second distance between the second coil winding part 42 and the third coil winding pair 43), and the size of the system can be reduced.

[0133] In some embodiments, the primary coil and the secondary coil of each pair of the at least one pair of coil windings may be relatively spaced apart (i.e., physically non-contacting), and a spacing may be provided between the primary coil and the secondary coil (e.g., spacings d_1 and d_2 shown in FIG. 7). The spacing between the primary coil and the secondary coil may affect an energy transmission efficiency, a data transmission bit error rate, etc. In some embodiments, in order to improve the energy transmission efficiency and the accuracy of data transmission, the spacing between the primary coil and the secondary coil of each pair of the at least one pair of coil windings may be within a preset range (e.g., 2 mm-5 mm). Preferably, the spacing between the primary coil and the secondary coil of each pair of the at least one pair of coil windings may be 3

mm.

[0134] In some embodiments, the spacings between the primary coils and the secondary coils of different pairs of coil windings may be the same or different. For example, if the at least one pair of coil windings include the first coil winding pair 41, the second coil winding pair 42, and the third coil winding pair 43, the spacing between the primary coil and the secondary coil of the first coil winding pair 41, the second coil winding pair 42, and the third coil winding pair 43 may be the same (e.g., 3 mm). Merely by way of example, in FIG. 7, the primary coils of the first coil winding pair 41, the second coil winding pair 42, and the third coil winding pair 43 may be disposed on a fixed mechanism 200, and the secondary coils of the first coil winding pair 41, the second coil winding pair 42, and the third coil winding pair 43 may be disposed on a rotating mechanism 300. A spacing between the primary coil and the secondary coil of the first coil winding pair 41 shown in FIG. 7 may be denoted as d_1 , and a spacing between the primary coil and the secondary coil of the second coil winding pair 42 and a spacing between the primary coil and the secondary coil of the third coil winding pair 43 may be denoted as d_2 , and d_1 may be equal to d_2 . As another example, if the at least one pair of coil windings include the first coil winding pair 41, the second coil winding pair 42, and the third coil winding pair 43, the spacing between the primary coil and the secondary coil of the first coil winding pair 41, the second coil winding pair 42, and the third coil winding pair 43 may be different. As another example, if the at least one pair of coil windings include the first coil winding pair 41, the second coil winding pair 42, and the third coil winding pair 43, the spacing between the primary coil and the secondary coil of the third coil winding pair 43 and the spacing between the primary coil and the secondary coil of the second coil winding pair 42 may be the same and different from the spacing between the primary coil and the secondary coil of the first coil winding pair 41. Merely by way of example, the spacing between the primary coil and the secondary coil of the first coil winding pair 41 shown in FIG. 7 may be denoted as d_1 , the spacing between the primary coil and the secondary coil of the second coil winding pair 42 and the spacing between the primary coil and the secondary coil of the third coil winding pair 43 may be denoted as d_2 , and d_1 may be unequal to d_2 .

[0135] In some embodiments, the non-contact coupling apparatus may further include a U-shaped isolation layer. The U-shaped isolation layer may be configured to wrap non-opposing surfaces of each pair of the at least one pair of coil windings. If the primary coil and the secondary coil of each pair of the at least one pair of coil windings are oppositely disposed in the axial direction or the radial direction, the primary coil may have a surface opposite to the secondary coil, which is referred to as an opposing surface of the primary coil, and remaining surfaces of the primary coil are referred to as the non-opposing surfaces of the primary coil. Similarly, the secondary coil may have a surface opposite to the primary coil, which is referred to as an opposing surface of the secondary coil, and remaining surfaces of the secondary coil are referred to as the non-opposing surfaces of the secondary coil. In some embodiments, a U-shaped isolation layer 700 may have a U-shaped structure. Taking FIG. 7 as an example, three U-shaped isolation layers 700 may wrap non-opposing surfaces of a first primary coil 411 and a first secondary coil 412 of the first coil winding pair 41, non-opposing surfaces of a second primary coil 421 and a second secondary coil 422 of the

second coil winding pair 42, and non-opposing surfaces of the third primary coil 431 and the third secondary coil 432 of the third coil winding pair 43. By providing the U-shaped isolation layer, magnetic leakage of the first coil winding pair 41, the second coil winding pair 42, and the third coil winding pair 43 may be minimized. In some embodiments, the U-shaped isolation layer may be made of a high magnetic permeability material.

[0136] In some embodiments, the U-shaped isolation layer may have structures of other different shapes (such as a hollow structure with one surface open (e.g., a hollow cube with one surface open)), as long as the structure wraps the non-opposite surfaces of the coil. The structure of the U-shaped isolation layer is not limited in the present disclosure.

[0137] In some embodiments, the at least one pair of coil windings may implement the transmission either in a resonant coupling manner or a non-resonant coupling manner. The non-contact coupling apparatus may include but is not limited to electromagnetic resonant coupling, such as magnetically loose coupling, electric-field coupling, or the like, or other forms of energy transmission of non-resonant coupling.

[0138] FIG. 3 is an overall view illustrating an exemplary non-contact transmission system according to some embodiments of the present disclosure. FIG. 4 is a cross-sectional oblique view illustrating an exemplary non-contact transmission system according to some embodiments of the present disclosure. FIG. 5 is a three-dimensional left view illustrating an exemplary non-contact transmission system according to some embodiments of the present disclosure. FIG. 6 is a cross-sectional view illustrating an exemplary non-contact transmission system according to some embodiments of the present disclosure. FIG. 7 is a schematic diagram illustrating an exemplary two-dimensional structure of a non-contact transmission system according to some embodiments of the present disclosure. FIG. 8 is a cross-sectional front view illustrating an exemplary non-contact transmission system according to some embodiments of the present disclosure. Referring to FIG. 3-FIG. 8, the first coil winding pair 41 designed and used for the main power transmission component 1 in the schematic diagram of the embodiment may be a pair of axially opposite winding coils, a first primary coil on a fixed mechanism 200 and a first secondary coil on a rotating mechanism 300 may include 4-5 turns of windings, and a spacing d_1 between the first primary coil and the first secondary coil may be an order of 3 mm (millimeter) or several mm. The rotation direction of the rotating mechanism 300 may be shown in the FIG. 8. The second coil winding pair 42 designed and used for the auxiliary power with carrier signal transmission component 2 may be a pair of radially opposite winding coils, a second primary coil on the fixed mechanism 200 and a second secondary coil on the rotating mechanism 300 may include 10 turns of windings, and a spacing d_2 between the second primary coil and the second secondary coil may be an order of 3mm or several mm. The third coil winding pair 43 designed and used for the data transmission component 3 may be a pair of radially opposite winding coils, a count of turns of a third primary coil on the rotating mechanism 300 and a count of turns of a third secondary coil on the fixed mechanism 200 may be 42 and 39, respectively, and a spacing d_2 between the third primary coil and the third secondary coil may be an order of 3 mm or several mm. The three coil windings may be designed to implement wrapping on three surfaces with a U-shaped ferrite core (or a high magnetic permeability material such as silicon steel), and a fourth surface of each of the three coil windings may be retained to match an opposite coil in pairs. Such structural

design can ensure magnetic leakage to be minimized, thereby ensuring the power and efficiency of electromagnetic resonance coupling. The at least one pair of winding coils needs to be insulated to prevent arcing, such as using insulating colloid to seal exposed surfaces of windings of an electromagnetic coupler.

[0139] In some embodiments, one or more capacitively coupled electrostatic discharge devices and/or electrical connections in the form of brushes (e.g., a metal brush, an alloy brush, a carbon brush, and other wear-resistant conductors) may be disposed between the stationary segment and the rotational segment of the non-contact transmission system, and the stationary segment may have good electrical grounding to ensure the electrical safety of the rotational segment and the entire system.

[0140] Different from the at least one pair of coil windings including three pairs of coil windings, in some embodiments, the at least one pair of coil windings may include a pair of coil windings. The primary coil of the pair of coil windings may be connected with the stationary segment corresponding to a fixed mechanism, and the secondary coil of the pair of coil windings may be connected with the rotational segment corresponding to the rotating mechanism. The pair of coil windings may be configured to implement a transmission of power (e.g., first power and/or second power) and signals (e.g., control signals, feedback signals, and/or scanning data signals) between the stationary segment and the rotational segment.

[0141] FIG. 9A is a schematic diagram illustrating an exemplary process of a transmission of power and signals of a non-contact transmission system according to some embodiments of the present disclosure. FIG. 9B is a schematic diagram illustrating an exemplary electrical and electronic structure of a non-contact transmission system according to some embodiments of the present disclosure. FIG. 9A and FIG. 9B shows that at least one pair of coil windings 40 may include a pair of coil windings (e.g., a coil winding pair 60). As shown in FIG. 9A and FIG. 9B, a primary coil 61 of the coil winding pair 60 may be connected with a stationary segment, and a secondary coil 62 of the coil winding pair 60 may be connected with a rotational segment. The primary coil 61 and the secondary coil 62 may be disposed in a non-contact coupling manner. Merely by way of example, a stationary segment mounted on the fixed mechanism 200 may include an external power supply, a rectifier and filter A, a DC/DC converter, an inverter A, a controller circuit, a first power line carrier modulation circuit, a resonant circuit, etc., and the rotational segment mounted on the rotating mechanism 300 may include a battery module, a carrier signal extraction and envelope detection demodulation circuit, main power consumption devices, etc. A voltage provided by the external power supply may be input into the DC/DC converter through the rectifier and filter A disposed on the fixed mechanism 200. After a baseband digital signal corresponding to control signal information is subjected to binary amplitude shift keying amplitude modulation and digital signal processing by the first power line carrier modulation circuit, a voltage output of the DC/DC converter may be quickly controlled and changed by the controller circuit. A DC voltage output may be used as a DC voltage input of the inverter A and carry a modulated digital signal. The inverter A may transmit a voltage with an amplitude envelope feature to the rotational segment through the primary coil 61 and the secondary coil 62 by electromagnetic induction resonance

coupling. The carrier signal extraction and envelope detection demodulation circuit may extract and demodulate the voltage with the amplitude envelope feature to restore the baseband digital signal, i.e., to realize synchronous non-contact electromagnetic resonance coupling transmission of the control signals and the power. In some embodiments, the non-contact transmission system may further include a second power line carrier modulation circuit disposed on the rotating mechanism and a carrier signal extraction and demodulation circuit disposed on the fixed mechanism. The second power line carrier modulation circuit may be configured to modulate scanning data signals and/or feedback signals of the rotational segment according to preset spectrum point requirements, and control an operating frequency of the inverter of the rotational segment based on the spectrum points, to load the scanning data signals and/or the feedback signals into a voltage waveform of the secondary coil 62 disposed on the rotating mechanism. The secondary coil 62 may transmit the voltage waveform to the primary coil 61 disposed on the fixed mechanism through electromagnetic resonance coupling. The carrier signal extraction and demodulation circuit may extract a carrier signal from the voltage waveform of the primary coil 61 based on the operating frequency and demodulate the carrier signal into a digital signal, thereby realizing the transmission of the scanning data signals and the feedback signals.

[0142] A data transmission component may include or not include the second power line carrier modulation circuit and the carrier signal extraction and demodulation circuit according to an actual situation (whether modulation and demodulation are required).

[0143] By setting one pair of coil windings, the structure of the non-contact transmission system can be simpler, and the cost can be reduced.

[0144] FIG. 9C is a schematic diagram illustrating another exemplary process of a transmission of power and signals of a non-contact transmission system according to some embodiments of the present disclosure. Referring to FIG. 9C, the primary coil 61 of the at least one pair of coil windings 40 may be disposed on the fixed mechanism 200, and the secondary coil 62 of the at least one pair of coil windings 40 may be disposed on the rotating mechanism 300. A spacing between the primary coil 61 and the secondary coil 62 may be denoted as $d1$. The U-shaped isolation layer 700 may wrap non-opposing surfaces of the primary coil 61 and the secondary coil 62, respectively.

[0145] Different from the at least one pair of coil windings including three pairs of coil windings, in some embodiments, the at least one pair of coil windings may include two pairs of coil windings. One pair of the two pairs of coil windings may be configured to implement the transmission of the power (e.g., the first power and/or the second power) from the stationary segment to the rotational segment, and the other pair of the two pairs of coil windings may be configured to implement the transmission of the scanning data signals and/or the feedback signals from the rotational segment to the stationary segment, and/or voltage carrier communication of control signals from the stationary segment to the rotational segment.

[0146] FIG. 9D is a schematic diagram illustrating another exemplary process of a transmission of power and signals of a non-contact transmission system according to some embodiments of the present disclosure. FIG. 9E is a schematic diagram illustrating an exemplary electrical and electronic structure of a non-contact transmission system according to some embodiments of the

present disclosure. FIG. 9D and FIG. 9E shows at least one pair of coil windings 40 including a coil winding pair 71 and a coil winding pair 72. As shown in FIG. 9D and FIG. 9E, a primary coil 711 of the coil winding pair 71 may be connected with a stationary segment, and a secondary coil 712 of the coil winding pair 71 may be connected with a rotational segment. The primary coil 711 and the secondary coil 712 may be disposed in a non-contact coupling manner. A primary coil 721 of the coil winding pair 72 may be disposed on the stationary segment, a secondary coil 722 of the coil winding pair 72 may be connected with the rotational segment, and the primary coil 721 and the secondary coil 722 may be disposed in a non-contact coupling manner. Merely by way of example, a stationary segment disposed on the fixed mechanism may include a power supply, a rectifier and filter A, a DC/DC converter, an inverter A, a drive circuit controller, a first power line carrier modulation circuit, a resonant circuit, etc., and a rotational segment disposed on the rotating mechanism may include a rectifier and filter B, an inverter B, a battery module, a carrier signal extraction and envelope detection demodulation circuit, a main power device, etc. Power output by the power supply may reach a resonant circuit unit through the rectifier filter A, the DC/DC converter, and the inverter A disposed of the stationary segment in sequence. The resonant circuit may transmit the power to the primary coil 711. The primary coil 711 may transmit the power to the secondary coil 712 by electromagnetic resonance coupling, thereby supplying power to one or more main power consumption devices (e.g., an X-ray tube) and one or more auxiliary power devices of the rotational segment. The first power line carrier modulation circuit may control an output voltage of the DC/DC converter based on control signals of the stationary segment such that the output voltage may have an amplitude envelope feature. The output voltage of the DC/DC converter may be transmitted to the secondary coil 722 disposed on the rotating mechanism through the primary coil 721 disposed on the fixed mechanism. The carrier signal extraction and envelope detection demodulation circuit may extract an envelope from a voltage carrier of the secondary coil 722 and demodulate the envelope into a digital signal containing control signal information to realize control signal transmission. In some embodiments, the non-contact transmission system may further include a second power line carrier modulation circuit disposed on the rotational mechanism and a carrier signal extraction and demodulation circuit disposed on the fixed mechanism. The second power line carrier modulation circuit may be configured to modulate scanning data signals and/or feedback signals of the rotational segment according to preset spectrum point requirements, and control an operating frequency of the inverter unit disposed on the rotating mechanism based on spectrum points, so as to load the scanning data signals and/or the feedback signals into a voltage waveform of the secondary coil 722 disposed on the rotating mechanism. The secondary coil 722 may transmit the voltage waveform to the primary coil 721 disposed on the fixed mechanism through electromagnetic resonance coupling. The carrier signal extraction and demodulation circuit may extract a carrier signal from the voltage waveform of the primary coil 721 based on the operating frequency and demodulate the carrier signal into a digital signal, thereby realizing the transmission of the scanning data signals and the feedback signals.

[0147] By providing the two pairs of coil windings (e.g., the coil winding pair 71 and the coil winding pair 72), the two pairs of coil windings may be used for power transmission and data

transmission, respectively, so that the structure of the non-contact transmission system can be simpler, the cost can be reduced, and a relatively high transmission efficiency can be ensured.

[0148] FIG. 9F is a schematic diagram illustrating another exemplary process of a transmission of power and signals of a non-contact transmission system according to some embodiments of the present disclosure. Referring to FIG. 9F, the first primary coil 711 of the first coil winding pair 71 may be disposed on the fixed mechanism 200, and the first secondary coil 712 of the first coil winding pair 71 may be disposed on the rotating mechanism 300. A spacing between the first primary coil 711 and the first secondary coil 712 may be denoted as d_1 . The second primary coil 721 of the second coil winding pair 72 may be disposed on the fixed mechanism 200, and the second secondary coil 722 of the second coil winding pair 72 may be disposed on the rotating mechanism 300. A spacing between the second primary coil 721 and the second secondary coil 722 may be denoted as d_2 . The U-shaped isolation layer 700 may wrap non-opposite surfaces of the first primary coil 711, the first secondary coil 712, the second primary coil 721, and the second secondary coil 722, respectively.

[0149] In some embodiments, the non-contact transmission system may further include a power supply circuit disposed at the rotating mechanism. The power supply circuit may be configured to store power converted from thermal energy of the system. The power may be used to be supplied to the one or more auxiliary power devices disposed at the rotating mechanism.

[0150] In some embodiments, if the at least one pair of coil windings include two pairs of coil windings, one pair of the two pairs of coil windings may be configured to implement the transmission of the power (e.g., the first power and the second power) from the stationary segment to the rotational segment, and voltage carrier communication of control signals from the stationary segment to the rotational segment, and the other pair of the two pairs of coil windings may be configured to implement the transmission of the scanning data signals and the feedback signals from the rotational segment to the stationary segment.

[0151] Merely by way of example, a voltage provided by an external power supply may be input to the DC/DC converter through the rectifier and filter A disposed on the fixed mechanism. After the first power line carrier modulation circuit performs binary amplitude shift keying (2ASK) amplitude modulation and digital signal processing on a baseband digital signal corresponding to the control signal information, the controller circuit may quickly control and change a voltage output of the DC/DC converter unit. The DC voltage output may be used as a DC voltage input of the inverter A and carry a modulated digital signal. The inverter A may transmit a voltage with an amplitude envelope feature to the rotating mechanism through the primary coil 711 and the secondary coil 712 by electromagnetic induction resonant coupling. The carrier signal extraction and envelope detection demodulation circuit may extract and demodulate the voltage with the amplitude envelope feature, thereby restoring the baseband digital signal, i.e., realizing the synchronous non-contact electromagnetic resonant coupling transmission of the control signals and the power. The second power line carrier modulation circuit may be configured to modulate the scanning data signals and/or the feedback signals of the rotational segment according to preset spectrum point requirements, and control the operating frequency of the inverter disposed on the rotating mechanism based on the

spectrum points, so as to load the scanning data signals and/or the feedback signals into a voltage waveform of the secondary coil 722 disposed on the rotating mechanism. The secondary coil 722 may transmit the voltage waveform to the primary coil 721 disposed on the fixed mechanism through electromagnetic resonance coupling. The carrier signal extraction and demodulation circuit may extract a carrier signal from the voltage waveform of the primary coil 721 based on the operating frequency and demodulate the carrier signal into a digital signal, thereby realizing the transmission of the scanning data signals and the feedback signals. By setting the two pairs of coil windings, the two pairs of coil windings may be used for unidirectional transmission (e.g., the coil winding pair 71 may be used for unidirectional transmission from the stationary segment to the rotational segment, and the coil winding 72 may be used for unidirectional transmission from the rotational segment to the stationary segment) respectively according to a transmission direction. Such setting can reduce the cost while ensuring the high operating efficiency.

[0152] It should be noted that when the at least one pair of coil windings include different counts of pairs of coil windings, parameters of each pair of the at least one pair of coil windings, such as the spacing between the primary coil and the secondary coil, the relative arrangement of the primary coil and the secondary coil (e.g., radially opposite or axially opposite), the count of turns of the primary coil and the secondary coil, etc., can be set according to needs, which are not specifically limited here.

[0153] Different from the magnetic coupling form (i.e., using the at least one pair of coil windings to implementing the transmission between the stationary segment and the rotational segment), in some embodiments, the non-contact coupling apparatus may be disposed in a capacitive coupling manner.

[0154] In some embodiments, the non-contact coupling apparatus may include at least one capacitive coupling circuit. A primary side (e.g., a primary capacitive plate) of the capacitive coupling circuit may be connected with the stationary segment corresponding to the fixed mechanism, and a secondary side (e.g., a secondary capacitive plate) of the capacitive coupling circuit may be connected with the rotational segment corresponding to the rotating mechanism. The at least one capacitive coupling circuit may be configured to implement a transmission of power and signals between the stationary segment and the rotational segment.

[0155] In some embodiments, the capacitive coupling circuit may include the primary capacitive plate and the secondary capacitive plate. The primary capacitive plate may serve as the primary side of the capacitive coupling circuit, and the secondary capacitive plate may serve as the secondary side of the capacitive coupling circuit. The primary capacitive plate and the secondary capacitive plate may be mutually coupled in a non-physical contact manner. The primary capacitive plate and the secondary capacitive plate may be configured to implement the transmission of the power and the signals between the stationary segment and the rotational segment.

[0156] In some embodiments, the at least one capacitive coupling circuit may include three capacitive coupling circuits, such as a first capacitive coupling circuit, a second capacitive coupling circuit, and a third capacitive coupling circuit. The first capacitive coupling circuit may be configured to implement a transmission of first power from the stationary segment to the rotational segment to

supply power to main power consumption devices (e.g., a radiation source) disposed on the rotating mechanism. The second capacitive coupling circuit may be configured to implement a transmission of second power from the stationary segment to the rotational segment to supply power to auxiliary power devices disposed on the rotating mechanism, and implement a transmission of control signals from the stationary segment to the rotational segment through voltage carrier communication. The third capacitive coupling circuit may be configured to implement a transmission of scanning data signals and feedback signals from the rotational segment to the stationary segment. More descriptions regarding the at least one capacitive coupling circuit including the three capacitive coupling circuits may be found in FIGs. 9G -10A and related descriptions thereof.

[0157] In some embodiments, the at least one capacitive coupling circuit may include one capacitive coupling circuit. The capacitive coupling circuit may be configured to implement the transmission of the power and the signals between the stationary segment and the rotational segment. For example, the capacitive coupling circuit may simultaneously implement the transmission of the power from the stationary segment to the rotational segment, the transmission of the control signals from the stationary segment to the rotational segment, and the transmission of the scanning data signals and/or the feedback signals from the rotational segment to the stationary segment. More descriptions regarding the at least one capacitive coupling circuit including the capacitive coupling circuit may be found in FIG. 10B and related descriptions thereof.

[0158] In some embodiments, the at least one capacitive coupling circuit may include two capacitive coupling circuits. One of the two capacitive coupling circuits may be configured to implement the transmission of the power from the stationary segment to the rotational segment; the other of the two capacitive coupling circuits may be configured to implement the transmission of the scanning data signals and the feedback signals from the rotational segment to the stationary segment, and the voltage carrier communication of the control signals from the stationary segment to the rotational segment. In some embodiments, one of the two capacitive coupling circuits may be configured to implement the transmission of the power from the stationary segment to the rotational segment, and the voltage carrier communication of the control signals from the stationary segment to the rotational segment, and the other of the two capacitive coupling circuits may be configured to implement the transmission of the scanning data signals and the feedback signals from the rotational segment to the stationary segment. More descriptions regarding the at least one capacitive coupling circuit including the two capacitive coupling circuits may be found in FIG. 10C and related descriptions thereof.

[0159] In some embodiments, the at least one capacitive coupling circuit may include three capacitive coupling circuits. FIG. 9G is a schematic diagram illustrating a further exemplary process of a transmission of power and signals of a non-contact transmission system according to some embodiments of the present disclosure. FIG. 10A is a schematic diagram illustrating an exemplary electrical and electronic structure of a non-contact transmission system according to some embodiments of the present disclosure. Referring to FIG. 9G and FIG. 10A, at least one capacitive coupling circuit 50 may include a first capacitive coupling circuit 51, a second capacitive coupling circuit 52, and a third capacitive coupling circuit 53. A first primary capacitive plate of the

first capacitive coupling circuit 51 may be connected with a stationary segment, and a first secondary capacitive plate of the first capacitive coupling circuit 51 may be connected with a rotational segment. The first capacitive coupling circuit 51 may be configured to implement a transmission (also referred to as main power transmission) of first power from the stationary segment to the rotational segment to supply power to main power consumption devices (e.g., radiation source) disposed on the rotational segment. A second primary capacitive plate of the second capacitive coupling circuit 52 may be connected with the stationary segment, and a second secondary capacitive plate of the second capacitive coupling circuit 52 may be connected with the rotational segment. The second capacitive coupling circuit 52 may be configured to implement a transmission (also referred to as auxiliary power transmission) of second power from the stationary segment to the rotational segment, and a transmission (also referred to as carrier signal transmission) of control signals from the stationary segment to the rotational segment through voltage carrier communication. The second power may be configured to supply power to one or more auxiliary power devices (e.g., the high voltage generator, and the battery module) of the rotational segment. A third primary capacitive plate of the third capacitive coupling circuit 53 may be connected with the rotating mechanism, and a third secondary capacitive plate of the third capacitive coupling circuit 53 may be connected with the stationary segment. The third capacitive coupling circuit 53 may be configured to implement a transmission (also referred to as high-speed data transmission) of scanning data signals and/or feedback signals from the rotational segment to the stationary segment.

[0160] In some embodiments, similar to the electrical and electronic structure of the non-contact transmission system in FIG. 2, the non-contact transmission system in FIG. 10A may include the external power supply 16 and the main power transmission component 1. The external power supply 16 may be configured to supply power. The main power transmission component 1 may be configured to implement the transmission of the first power. In some embodiments, the main power transmission component 1 may be configured to implement the transmission of the first power from the stationary segment to the rotational segment of the system based on a capacitive coupling technology to supply the first power to the main power consumption devices disposed on the rotational segment. For example, the main power transmission component 1 may be configured to implement the transmission of the first power from the stationary segment to the rotational segment of the system through the first capacitive coupling circuit 51.

[0161] In some embodiments, the main power transmission component 1 may include a high-frequency AC voltage output circuit 11 disposed on the stationary segment and a main power output circuit 13 disposed on the rotational mechanism. The high-frequency AC voltage output circuit 11 may include an isolation transformer 111, a first rectifier and filter 112, and a first inverter 113 connected in sequence. In some embodiments, the main power output circuit 13 may include a second rectifier and filter unit 131 and a fourth inverter unit 132 connected in sequence.

[0162] In some embodiments, the external power supply 16 may be a three-phase external power supply. A 380 V AC voltage provided by the external power supply 16 may pass through the first rectifier and filter 112 through the isolation transformer 111, to the first inverter 113 (i.e., the high-

frequency inverter unit) through a DC bus to output a high-frequency AC voltage.

[0163] In some embodiments, the main power transmission component 1 may further include a drive circuit controller 14 disposed on the fixed mechanism. The drive circuit controller 14 may be configured to control a set of power semiconductor switching components of the first inverter 113 to adjust a real-time output voltage of the high-frequency AC voltage output circuit 11.

[0164] It should be noted that electrical and electronic devices (e.g., the external power supply 16, the main power transmission component 1, the high-frequency AC voltage output circuit 11, the main power output circuit 13, the isolation transformer 111, the first rectifier and filter 112, the first inverter 113, the drive circuit controller 14, the second rectifier and filter unit 131, the fourth inverter unit 132, etc.) of the non-contact transmission system in FIG. 10A may be substantially the same as the corresponding electrical and electronic devices of the non-contact transmission system in FIG. 2 in terms of functions, connection modes, etc., which are not repeated here.

[0165] In some embodiments, similar to the electrical and electronic structure of the non-contact transmission system in FIG. 2, the non-contact transmission system in FIG. 10A may include the auxiliary power with carrier signal transmission component 2. The auxiliary power with carrier signal transmission component 2 may include a first power line carrier modulation circuit 21, a DC/DC converter 22, and a second inverter 23 disposed on the fixed mechanism, and a carrier signal extraction and envelope detection demodulation circuit 25 disposed on the rotating mechanism. The first power line carrier modulation circuit 21 may be configured to control an output voltage of the DC/DC converter 22 based on control signals of the stationary segment such that the output voltage has an amplitude envelope feature. The amplitude envelope feature may be configured to characterize information of the control signals. The output voltage of the DC/DC converter 22 may be transmitted to the second secondary capacitive plate of the second capacitor coupling circuit 52 disposed on the rotating mechanism through the second primary capacitive plate of the second capacitor coupling circuit 52 disposed on the fixed mechanism. The carrier signal extraction and envelope detection demodulation circuit 25 may be configured to extract an envelope from a voltage carrier of the second secondary capacitive plate and demodulate the envelope into a digital signal.

[0166] In this embodiment, the auxiliary power with carrier signal transmission component 2 may synchronously transmit the power and the control signals from the stationary segment to the rotational segment of the system through the second capacitive coupling circuit 52 using a power line carrier technology. An external power supply of the auxiliary power transmission module may be supplied by an ordinary 220V AC single-phase external power supply, or may be designed to take one phase from three-phase grid (before passing through the isolation transformer) of a main power transmission module, thereby reducing the site configuration requirements of one power input port/socket.

[0167] It should be noted that the electrical and electronic devices (e.g., the auxiliary power with carrier signal transmission component 2, the first power line carrier modulation circuit 21, the DC/DC converter 22, the second inverter 23, the carrier signal extraction and envelope detection demodulation circuit 25, etc.) of the non-contact transmission system in FIG. 10A may be

substantially the same as the corresponding electrical and electronic devices of the non-contact transmission system in FIG. 2 in terms of functions, connection modes, etc., which are not repeated here.

[0168] In some embodiments, similar to the electrical and electronic structure of the non-contact transmission system in FIG. 2, the non-contact transmission system in FIG. 10A may include the data transmission component 3. The data transmission component 3 may include a battery module 31, a second power line carrier modulation circuit 32, a third inverter unit 34, and a power amplifier 35 disposed on the rotating mechanism, and a carrier signal extraction and demodulation circuit 36 disposed on the fixed mechanism. The electrical and electronic devices (e.g., the data transmission component 3, the battery module 31, the second power line carrier modulation circuit 32, the third inverter unit 34, the power amplifier 35, the carrier signal extraction and demodulation circuit 36, etc.) of the non-contact transmission system in FIG. 10A may be substantially the same as the corresponding electrical and electronic devices of the non-contact transmission system in FIG. 2 in terms of functions, connection modes, etc., which are not repeated here.

[0169] In some embodiments, at least one side of the at least one capacitive coupling circuit may be connected with a resonant circuit. The resonant circuit may be configured to optimize a resonant frequency of the system. In some embodiments, the main power transmission component 1 may also include a first resonant circuit 12. The first resonant circuit 12 may be electrically connected with a high-frequency AC voltage output circuit 11 and a first primary capacitive plate of a first capacitive coupling circuit 51, respectively, and configured to set a resonant frequency point of the first primary capacitive plate of the first capacitive coupling circuit 51 to optimize a power level and efficiency of the non-contact power transmission.

[0170] In some embodiments, the main power transmission component 1 may further include a second resonant circuit 15. The second adaptive optimization resonant circuit 15 may be disposed on the rotating mechanism and electrically connected with the main power output circuit 13 and a first secondary capacitive plate of the first capacitive coupling circuit 51, respectively.

[0171] In some embodiments, the auxiliary power with carrier signal transmission component 2 may include a third resonant circuit 24. In some embodiments, the data transmission component 3 may include a fourth resonant circuit 33. It should be noted that the main power transmission component 1, the auxiliary power with carrier signal transmission component 2, and the data transmission component 3 may include the resonant circuit, respectively. In some embodiments, some of the main power transmission component 1, the auxiliary power with carrier signal transmission component 2, and the data transmission component 3 may include the resonant circuit. In some embodiments, none of the main power transmission component 1, the auxiliary power with carrier signal transmission component 2, and the data transmission component 3 may include the resonant circuit. The resonant circuit unit may be set based on the requirements (e.g., the structural requirements of the capacitive coupling circuit), which is not specifically limited here.

[0172] Using the capacitive coupling circuit to achieve the transmission of the power and the scanning data signals between the stationary segment and the rotational segment can reduce the bit error rate during the transmission process and improve the accuracy of the data transmission.

[0173] Different from the at least one capacitive coupling circuit including the three capacitive coupling circuits in FIG. 9C, in some embodiments, the at least one capacitive coupling circuit may include one capacitive coupling circuit. A primary capacitive plate and a secondary capacitive plate of the capacitive coupling circuit may be disposed on the fixed mechanism and the rotating mechanism, respectively. The capacitive coupling circuit may be configured to implement a transmission of power (e.g., the first power and/or the second power) and signals (e.g., the control signals, the feedback signals, and/or the scanning data signals) between the stationary segment and the rotational segment.

[0174] FIG. 10B is a schematic diagram illustrating an exemplary process of a transmission of power and signals of a non-contact transmission system according to some embodiments of the present disclosure. FIG. 10B shows that at least one capacitive coupling circuit 50 may include a capacitive coupling circuit. As shown in FIG. 10B, a primary capacitive plate 81 of the capacitive coupling circuit may be connected with a fixed mechanism, and a secondary capacitive plate 82 of the capacitive coupling circuit may be connected with a rotational segment. The primary capacitive plate 81 and the secondary capacitive plate 82 may be disposed in a non-contact coupling manner. Merely by way of example, a voltage supplied by an external power supply may be input to a DC/DC converter through a rectifier and filter disposed on the fixed mechanism. A first power line carrier modulation circuit may perform binary amplitude shift keying amplitude modulation and digital signal processing on a baseband digital signal corresponding to control signal information, and a controller circuit may quickly control and change a voltage output of the DC/DC converter. The DC voltage output may be used as a DC voltage input of the inverter and carry a modulated digital signal. The inverter unit may transmit a voltage with an amplitude envelope feature to the rotational segment through the primary capacitive plate 81 and the secondary capacitive plate 82 through capacitive coupling, and a carrier signal extraction and envelope detection demodulation circuit may extract and demodulate the voltage with the amplitude envelope feature to restore a baseband digital signal, i.e., to realize the synchronous non-contact coupling transmission of the control signals and the power. A second power line carrier modulation circuit may modulate scanning data signals and/or feedback signals of the rotational segment according to preset spectrum point requirements, and control an operating frequency of the inverter of the rotational segment based on spectrum points, so as to load the scanning data signals and/or the feedback signals into a voltage waveform of the secondary capacitive plate 82 disposed on the rotating mechanism. The secondary capacitive plate 82 may transmit the voltage waveform to the primary capacitive plate 81 disposed on the fixed mechanism by capacitive coupling. The carrier signal extraction and demodulation circuit may extract a carrier signal from the voltage waveform of the primary capacitive plate 81 based on the operating frequency and demodulate the carrier signal into a digital signal, thereby realizing the transmission of the scanning data signals and the feedback signals.

[0175] By providing one capacitive coupling circuit, the bit error rate in the transmission process can be reduced, the structure of the non-contact transmission system can be simpler, and the cost can be reduced.

[0176] Different from the at least one capacitive coupling circuit including the three capacitive

coupling circuits in FIG. 9C in some embodiments, the at least one capacitive coupling circuit may include two capacitive coupling circuits. One of the two capacitive coupling circuits may be configured to implement a transmission of power from the stationary segment to the rotational segment, and the other of the two capacitive coupling circuits may be configured to implement a transmission of scanning data signals and/or feedback signals from the rotational segment to the stationary segment, and voltage carrier communication of control signals from the stationary segment to the rotational segment.

[0177] FIG. 10C is a schematic diagram illustrating another exemplary process of a transmission of power and signals of a non-contact transmission system according to some embodiments of the present disclosure. FIG. 10C shows that at least one capacitive coupling circuit 50 may include a capacitive coupling circuit 91 and a capacitive coupling circuit 92. As shown in FIG. 10C, a primary capacitive plate 911 of the capacitive coupling circuit 91 may be disposed on a fixed mechanism, and a secondary capacitive plate 912 of the capacitive coupling circuit 91 may be disposed on a rotating mechanism (e.g., rotating mechanism 300). The primary capacitive plate 911 and the secondary capacitive plate 912 may be disposed in a non-contact coupling manner. A primary capacitive plate 921 of the capacitive coupling circuit 92 may be connected with the stationary segment, and a secondary capacitive plate 922 of the capacitive coupling circuit 92 may be connected with a rotational segment. The primary capacitive plate 921 and the secondary capacitive plate 922 may be disposed in a non-contact coupling manner. Merely by way of example, power output by an external power supply may be input to the primary capacitive plate 911 through a rectifier and filter, a DC/DC converter, and an inverter unit disposed on the fixed mechanism in sequence. The primary capacitive plate 911 may transmit the power to the secondary capacitive plate 912 in a capacitive coupling manner to supply power to one or more main power consumption devices (e.g., an X-ray tube) and one or more auxiliary power devices disposed on the rotating mechanism. A first power line carrier modulation circuit may control an output voltage of the DC/DC converter based on control signals of the stationary segment, such that the output voltage may have an amplitude envelope feature. The output voltage of the DC/DC converter may be transmitted to the secondary capacitive plate 922 of the rotating side through the primary capacitive plate 921 connected with the stationary segment. A carrier signal extraction and envelope detection demodulation circuit may extract an envelope from a voltage carrier of the secondary capacitive plate 922 and demodulate the envelope into a digital signal containing control signal information to realize the transmission of the control signals. A second power line carrier modulation circuit may modulate scanning data signals and/or feedback signals of the rotational segment according to preset spectrum point requirements, and control an operating frequency of the inverter of the rotational segment based on spectrum points, so as to load the scanning data signals and/or the feedback signals into a voltage waveform of the secondary capacitive plate 922 connected with the rotational segment. The secondary capacitive plate 922 may transmit the voltage waveform to the primary capacitive plate 9211 connected with the stationary side by capacitive coupling. The carrier signal extraction and demodulation circuit may extract a carrier signal from the voltage waveform of the primary capacitive plate 921 based on the operating

frequency and demodulate the carrier signal into the digital signal, thereby realizing the transmission of the scanning data signals and the feedback signals.

[0178] By setting the two capacitive coupling circuits (the first capacitive coupling circuit and the second capacitive coupling circuit), the two capacitive coupling circuits may be responsible for the transmission of the power and the data, respectively, so that the structure of the non-contact transmission system can be simpler, the cost can be reduced, and a relatively high transmission efficiency can be ensured.

[0179] In some embodiments, when the at least one capacitive coupling circuit includes two capacitive coupling circuits, one of the two capacitive coupling circuits may be configured to implement the transmission of the power from the stationary segment to the rotational segment, and voltage carrier communication of the control signals from the stationary segment to the rotational segment, and the other of the two capacitive coupling circuits may be configured to implement transmission of the scanning data signals and the feedback signals from the rotational segment to the stationary segment. Merely by way of example, a voltage supplied by an external power supply may be input to the DC/DC converter through the rectifier and filter disposed on the stationary segment. The first power line carrier modulation circuit may perform binary amplitude shift keying amplitude modulation and digital signal processing on a baseband digital signal corresponding to the control signal information, and a controller circuit may quickly control and change the voltage output of the DC/DC converter. The DC voltage output may be used as a DC voltage input of the inverter and carry a modulated digital signal. The inverter may transmit the voltage with the amplitude envelope feature to the rotational segment through the primary capacitive plate 911 and the secondary capacitive plate 912 by capacitive coupling, and the carrier signal extraction and envelope detection demodulation circuit may extract and demodulate the voltage with the amplitude envelope feature to restore a baseband digital signal, i.e., to realize the synchronous non-contact coupling transmission of the control signals and the power. The second power line carrier modulation circuit may modulate the scanning data signals and/or the feedback signals of the rotational segment according to preset spectrum point requirements, and control the operating frequency of the inverter of the rotational segment based on spectrum points, so as to load the scanning data signals and/or the feedback signals into the voltage waveform of the secondary capacitive plate 922 connected with the rotational segment. The secondary capacitive plate 922 may transmit the voltage waveform to the primary capacitive plate 921 connected with the stationary segment by capacitive coupling. The carrier signal extraction and demodulation circuit may extract the carrier signal from the voltage waveform of the primary capacitive plate 921 based on the operating frequency and demodulate the carrier signal into the digital signal, thereby realizing the transmission of the scanning data signals and the feedback signals.

[0180] By setting the at least one capacitive coupling circuit including the two capacitive coupling circuits, the two capacitive coupling circuits may be configured to implement unidirectional transmission (e.g., the first capacitive coupling circuit 91 may be configured to implement unidirectional transmission from the stationary segment to the rotational segment, and the second capacitive coupling circuit 92 may be configured to implement unidirectional transmission from the

rotational segment to the stationary segment). Such setting can reduce the cost and ensure a relatively high work efficiency.

[0181] Different from the pure magnetic coupling form in FIG. 1B and the pure capacitive coupling form in FIG. 9C, in some embodiments, the non-contact coupling apparatus may be a combination of magnetic coupling and capacitive coupling.

[0182] In some embodiments, the non-contact coupling apparatus may include a capacitive coupling circuit and two pairs of coil windings. FIG. 11 is a schematic diagram illustrating an exemplary electrical and electronic structure of a non-contact transmission system according to some embodiments of the present disclosure. As shown in FIG. 11, the non-contact coupling apparatus may include a first coil winding pair 101, a second coil winding pair 102, and a third capacitive coupling structure 103. A first primary coil of the first coil winding pair 101 may be connected with a stationary segment, and a first secondary coil of the first coil winding pair 101 may be connected with a rotational segment. The first coil winding pair 101 may be configured to implement a transmission of first power from the stationary segment to the rotational segment to supply power to main power consumption devices disposed on the rotating mechanism (e.g., rotating mechanism 300). A second primary coil of the second coil winding pair 102 may be connected with a stationary segment, and a second secondary coil of the second coil winding pair 102 may be connected with a rotational segment. The second coil winding pair 102 may be configured to implement a transmission of second power from the stationary segment to the rotational segment, and transmission of control signals from the stationary segment to the rotational segment through voltage carrier communication. The second power may be configured to supply power to one or more auxiliary power devices of the rotational segment. A third primary capacitive plate of the third capacitive coupling circuit 103 may be connected with a stationary segment, and a third secondary capacitive plate of the third capacitive coupling circuit 103 may be connected with a rotational segment. The third capacitive coupling circuit 103 may be configured to implement a transmission of scanning data signals and/or feedback signals from the rotational segment to the stationary segment.

[0183] It should be noted that the electrical and electronic devices of the main power transmission component 1 in FIG. 11 may be substantially the same as the electrical and electronic devices of the main power transmission component 1 in FIG. 2, which are not repeated here. The electrical and electronic devices of the auxiliary power with carrier signal transmission component 2 in FIG. 11 may be substantially the same as the electrical and electronic devices of the auxiliary power with carrier signal transmission component 2 in FIG. 2, which are not repeated here. In some embodiments, the electrical and electronic devices of the data transmission component 3 in FIG. 11 may be substantially the same as the electrical and electronic devices of the data transmission component 3 in FIG. 2. In some embodiments, the electrical and electronic devices of the data transmission component 3 in FIG. 11 may be different from the electrical and electronic devices of the data transmission component 3 in FIG. 2. For example, the data transmission component 3 in FIG. 11 may not include one or more of the fourth adaptive optimization resonant circuit unit 33, the third inverter 34, the power amplifier 35, and the carrier signal extraction and demodulation circuit 36.

[0184] It should be noted that when the non-contact coupling apparatus includes a capacitive coupling circuit and two pairs of coil windings, in addition to the combination (i.e., the combination of the first coil winding pair 101, the second coil winding pair 102, and the third capacitive coupling structure 103) shown in FIG. 11, the combination of the capacitive coupling circuit and the two pairs of coil windings may be in other forms. For example, from top to bottom in FIG. 11, the non-contact coupling apparatus may include a first coil winding pair (configured to implement a transmission of main power), a second capacitive coupling circuit (configured to implement a transmission of auxiliary power and control signals), and a third coil winding pair (configured to implement a transmission of scanning data signals and feedback signals). As another example, the non-contact coupling apparatus may include a first capacitive coupling circuit (configured to implement a transmission of main power), a second coil winding pair (configured to implement a transmission of auxiliary power and control signals), and a third coil winding pair (configured to implement a transmission of scanning data signals and feedback signals).

[0185] In some embodiments, the non-contact coupling apparatus may include two capacitive coupling circuits and a pair of coil windings. FIG. 12 is a schematic diagram illustrating an exemplary electrical and electronic structure of a non-contact transmission system according to some embodiments of the present disclosure. As shown in FIG. 12, the non-contact coupling apparatus may include a first coil winding pair 111, a second capacitive coupling circuit 112, and a third capacitive coupling structure 113. A first primary coil of the first coil winding pair 111 may be connected with a stationary segment, and a first secondary coil of the first coil winding pair 111 may be connected with a rotational segment. The first coil winding pair 111 may be configured to implement a transmission of first power from the stationary segment to the rotational segment to supply power to main power consumption devices of the rotational segment. A second primary capacitive plate of the second capacitive coupling circuit 112 may be connected with the stationary segment, and a second secondary capacitive plate of the second capacitive coupling circuit 112 may be connected with the rotational segment. The second capacitive coupling circuit 112 may be configured to implement a transmission of second power from the stationary segment to the rotational segment, and a transmission of control signals from the stationary segment to the rotational segment through voltage carrier communication. The second power may be configured to supply power to auxiliary power devices disposed on the rotational segment. A third primary capacitive plate of the third capacitive coupling circuit 113 may be connected with the rotational segment, and a third secondary capacitive plate of the third capacitive coupling circuit 113 may be connected with the stationary segment. The third capacitive coupling circuit 113 may be configured to implement a transmission of scanning data signals and feedback signals from the rotational segment to the stationary segment.

[0186] It should be noted that the electrical and electronic components of the main power transmission component 1, the auxiliary power with carrier signal transmission component 2, and the data transmission component 3 in FIG. 12 may be substantially the same as the electrical and electronic components of the main power transmission component 1, the auxiliary power with carrier signal transmission component 2, and the data transmission component 3 in FIG. 2, which are not

repeated here.

[0187] It should be noted that when the non-contact coupling apparatus includes the capacitive coupling circuit and the two pairs of coil windings, in addition to the combination (i.e., the combination of the first coil winding pair 111, the second capacitive coupling circuit 112, and the third capacitive coupling structure 113) shown in FIG. 12, the combination of the capacitive coupling circuit and the two pairs of coil windings may be in other forms. For example, from top to bottom in FIG. 12, the non-contact coupling apparatus may include a first capacitive coupling circuit (configured to implement a transmission of main power), a second coil winding pair (configured to implement a transmission of auxiliary power and control signals), and a third capacitive coupling circuit (configured to implement a transmission of scanning data signals and feedback signals). As another example, the non-contact coupling apparatus may include a first capacitive coupling circuit (configured to implement a transmission of main power), a second capacitive coupling circuit (configured to implement a transmission of auxiliary power and control signals), and a third coil winding pair (configured to implement a transmission of scanning data signals and feedback signals).

[0188] In some embodiments, the non-contact coupling apparatus may include a capacitive coupling circuit and a pair of coil windings. A primary capacitive plate and a secondary capacitive plate of the capacitive coupling circuit may be disposed on the fixed mechanism and the rotating mechanism. A primary coil and a secondary coil of the pair of coil windings may be disposed on the fixed mechanism and the rotating mechanism. In some embodiments, the capacitive coupling circuit may be configured to implement a transmission of power from the stationary segment to the rotational segment. The pair of coil windings may be configured to implement a transmission of scanning data signals and feedback signals from the rotational segment to the stationary segment, and voltage carrier communication of control signals from the stationary segment to the rotational segment. In some embodiments, the capacitive coupling circuit may be configured to implement the transmission of the power from the stationary segment to the rotational segment and the voltage carrier communication of the control signals from the stationary segment to the rotational segment; and the pair of coil windings may be configured to implement the transmission of the scanning data signals and the feedback signals from the rotational segment to the stationary segment. In some embodiments, the pair of coil windings may be configured to implement the transmission of the power from the stationary segment to the rotational segment; and the capacitive coupling circuit the pair of coil windings may be configured to implement transmission of the scanning data signals and the feedback signals from the rotational segment to the stationary segment, and the voltage carrier communication of the control signals from the stationary segment to the rotational segment. In some embodiments, the pair of coil windings may be configured to implement the transmission of the power from the stationary segment to the rotational segment and the voltage carrier communication of the control signals from the stationary segment to the rotational segment; and the capacitive coupling circuit may be configured to implement the transmission of the scanning data signals and the feedback signals from the rotational segment to the stationary segment.

[0189] It should be noted that when the non-contact coupling apparatus includes the capacitive

coupling circuit and the pair of coil windings, the capacitive coupling circuit and the pair of coil windings may have other combinations. Any modification and change to the combination of the capacitive coupling circuit and the pair of coil windings are within the scope of protection of the present disclosure.

[0190] In some embodiments, referring to FIG. 2, the non-contact transmission system may further include a collaborative control component 37. The collaborative control component 37 may be configured to monitor and control collaborative operation of associated modules across the stationary segment and the rotational segment.

[0191] In some embodiments, the collaborative control component 37 may include a monitoring circuit and a control circuit. The control circuit may be connected with the monitoring circuit. The monitoring circuit may be configured to monitor an operation condition of each module of the rotational segment. The control circuit may be configured to control the collaborative operation of the associated modules across the stationary segment and the rotational segment based on feedback data from the monitoring circuit.

[0192] In some embodiments, the collaborative control component 37 may be disposed on the rotating mechanism (e.g., rotating mechanism 300), as shown in FIG. 2 or FIG. 9B. In some embodiments, the monitoring circuit of the collaborative control component 37 may be disposed on the rotating mechanism (e.g., rotating mechanism 300), and the control circuit of the collaborative control component 37 may be disposed on the fixed mechanism (e.g., the fixed mechanism 200). As shown in FIG. 9E, the collaborative control component 37 may include a monitoring circuit 371 disposed on the rotating mechanism (e.g., rotating mechanism 300) and a control circuit 372 disposed on the fixed mechanism (e.g., fixed mechanism 200). In some embodiments, the monitoring circuit and the control circuit may be disposed as required, which is not limited in the present disclosure. In some embodiments, the control circuit of the collaborative control component may control frequency parameter setting of the drive circuit controller 14.

[0193] In some embodiments, the collaborative control component 37 may be configured to monitor statuses of the main power transmission component 1, the auxiliary power with carrier signal transmission component 2, and the battery module (e.g., the battery module 31), adaptively adjust circuit parameters of the resonant circuit unit (e.g., the first resonant circuit 12 and the second resonant circuit 15), parameters of the drive circuit controller (the drive circuit controller 14, the gate driver 231), and the inverter unit (the first inverter 113 and the second inverter 23), to control the operating frequency and amplitude of the non-contact transmission system, thereby improving the energy transmission efficiency and the signal carrier transmission performance of the non-contact transmission system. For example, as shown in FIG. 9E, the monitoring circuit 371 disposed on the rotating mechanism (e.g., rotating mechanism 300) may be configured to monitor the main power consumption device 02, the envelope detection demodulation 25, and the battery module 31 in real time, and perform logical computation and determination, and implement the downlink transmission of the one or more feedback signals to the fixed side through the data transmission component 3 (e.g., the second power line carrier modulation circuit 32, the third inverter 34, the power amplifier 35, and the carrier signal extraction and demodulation circuit 36) and the non-contact coupling

apparatus. The control circuit 372 disposed on the fixed mechanism (e.g., fixed mechanism 200) may be configured to extract the one or more feedback signals from the baseband digital signals obtained by the carrier signal extraction and demodulation circuit 36, and perform logical determination, to adjust the circuit parameters of the first resonant circuit 12 and the second resonant circuit 15 and the parameters of the drive circuit controller 14 and the gate driver 231 in real time, thereby realizing optimal real-time adjustment of the non-contact transmission system.

[0194] In some embodiments, the monitoring circuit may be configured to monitor main power consumption devices (e.g., the main power consumption device 02) provided in the rotating mechanism; and the control circuit may be configured to control the collaborative operation of the associated modules across the fixed mechanism and the rotating mechanism. Specifically, in the non-contact transmission system, due to the huge system of the electronic and electrical structure, a plurality of drive circuits and intelligent controllers may be configured to monitor and control each module in real time to ensure good operation of the non-contact transmission system. For example, at least one collaborative control component 37 may be disposed on the rotating mechanism of the system to implement a collaborative operation control loop between an X-ray tube system, a main/auxiliary power system, and a data communication system. As another example, an electromagnetic resonant coupling state between the primary coil and the secondary coil of the at least one pair of coil windings may be achieved by setting a system operating frequency to a resonant frequency of the primary coil obtained by optimizing a resonant circuit (e.g., the first resonant circuit 12) connected with the primary coil. In some embodiments, the primary coil and the secondary coil may be connected with a resonant circuit (e.g., the first resonant circuit 12 and the second resonant circuit 15), respectively. The collaborative control component 37 may set the system operating frequency to an optimal frequency of the two resonant frequencies for the overall system performance (e.g., power output, and total efficiency) by calculating resonant frequencies Frequency 1 and Frequency 2 of the primary coil and the secondary coil.

[0195] Preferably, if it is necessary to consider reducing the power consumption and heat generation of the entire system to improve the overall system efficiency of the non-contact transmission system, a plurality of rectifier and filter units (e.g., the first rectifier and filter 112, the second rectifier and filter 131, and the third rectifier and filter 26) may be designed to be active, such as using an active rectifier circuit, etc., as the loss of active rectification is usually lower than that of diode rectification, which is beneficial to improving the overall efficiency.

[0196] The non-contact transmission system provided in the embodiments of the present disclosure can overcome the problems of high maintenance cost of carbon brush tracks, system complexity, high material cost of multi-conductor tracks, high cost of data communication subsystems, etc., of the conventional slip ring systems, and realize the high performance requirements of non-physical contact synchronous transmission of the power and the data of the slip ring system in a novel, reliable and low-cost manner.

[0197] The embodiments of the present disclosure further provide a medical system, comprising the non-contact transmission system 100 described in any embodiment of the present disclosure. In some embodiments, the medical system may include a CT equipment, a PET-CT equipment, or a

SPET-CT equipment etc. For example, the medical system may include the fixed mechanism 200, the rotating mechanism 300 configured to be rotatable relative to the fixed mechanism 200, an imaging assembly mounted on the rotating mechanism 300 and configured to acquire scanning data signals related with a subject, and a non-contact transmission assembly (the non-contact transmission system 100). The non-contact transmission assembly (the non-contact transmission system 100) configured to transmit power to the imaging assembly and transmit the scanning data signals from the imaging assembly to a processor for an image reconstruction in a non-physical contact manner. In some embodiments, a first part of the non-contact transmission assembly (e.g., the stationary segment of the non-contact transmission system 100) may be mounted on the fixed mechanism 200, and a second part of the non-contact transmission assembly (e.g., the rotational segment of the non-contact transmission system 100) may be mounted on the rotating mechanism 300. In some embodiments, the transmission of the power and the scanning data signals between the first part and the second part is implemented in a non-physical contact manner.

[0198] The main power consumption device 02 of the non-contact transmission assembly (non-contact transmission system 100) may be an X-ray tube of the medical system. The non-contact transmission assembly may supply power to the X-ray tube, such that the X-ray tube may scan the subject by emitting X-rays to the subject, and obtain scanning data.

[0199] In some embodiments, the non-contact transmission assembly may include at least one pair of coil windings. Each pair of the at least one pair of coil windings may be configured to implement a transmission of at least one of power and the scan data signals.

[0200] In some embodiments, each pair of the at least one pair of coil windings may be configured to implement the transmission of different types of information. The different types of information may include power, the scanning data signals, control signals and feedback signals.

[0201] For example, the non-contact transmission assembly may include a pair of coil windings. The pair of coil windings may be configured to simultaneously implement the transmission of the power (e.g., the first power and/or the second power) from the fixed mechanism 200 to the rotating mechanism 300, the transmission of one or more control signals from the fixed mechanism 200 to the rotating mechanism 300, and/or the transmission of the one or more scanning data signals and/or the one or more feedback signals from the rotating mechanism 300 to the fixed mechanism 200.

[0202] As another example, the non-contact transmission assembly may include two pairs of coil windings. One pair of the two pairs of coil windings may be configured to implement the transmission of the power (e.g., the first power and/or the second power) from the fixed mechanism 200 to the rotating mechanism 300; and the other pair of the two pairs of coil windings may be configured to implement the transmission of the one or more scanning data signals and/or the one or more feedback signals from the rotating mechanism 300 to the fixed mechanism 200, and the transmission (e.g., through a manner of voltage carrier communication) of the one or more control signals from the fixed mechanism 200 to the rotating mechanism 300.

[0203] As another example, the non-contact transmission assembly may include three pairs of coil windings, such as the first coil winding pair 41, the second coil winding pair 42, and the third coil

winding pair. The first coil winding pair 41 may be configured to implement the transmission of the first power from the fixed mechanism 200 to the rotating mechanism 300 to supply power to a X-ray tube; the second coil winding pair 42 may be configured to implement the transmission of the second power from the fixed mechanism 200 to the rotating mechanism 300 to supply power to one or more auxiliary power devices (e.g., a battery module, a high voltage generator, etc.) of the rotational segment and the transmission of the one or more control signals from the fixed mechanism 200 to the rotating mechanism 300; and the third coil winding pair 43 may be configured to implement the transmission of the one or more scanning data signals and/or the one or more feedback signals from the rotating mechanism 300 to the fixed mechanism 200.

[0204] In some embodiments, each pair of the at least one pair of coil windings may include a primary coil and a secondary coil. The primary coil may be mounted on the fixed mechanism 200, and the secondary coil may be mounted on the rotating mechanism 300. A space (e.g., the distance d_1 and d_2 shown in FIG. 7) may be provided between the primary coil and the secondary coil, so as to implement non-contact transmission of at least one of power, scanning data signals, control signals and feedback signal.

[0205] In some embodiments, the primary coil may be disposed surrounding the fixed mechanism 200, and the secondary coil may be disposed surrounding the rotating mechanism 300. The fixed mechanism 200 and the rotating mechanism 300 may be coaxially arranged, as shown in FIG. 4. For example, the primary coil may be wound clockwise surrounding an axis of the stationary segment 300 (e.g., embedded in a stator side of a bearing or a fixed portion of a slip ring connected with the bearing), and the secondary coil may be wound clockwise or counterclockwise surrounding the axis of the rotational segment 200 (e.g., embedded in a rotor side of the bearing or a rotational portion of the slip ring connected with the bearing).

[0206] More descriptions regarding the non-contact transmission assembly may be found in the descriptions of the non-contact transmission system 100, which are not repeated here.

[0207] The medical system provided in the embodiment, by utilizing the non-contact transmission assembly, can overcome the problems of high maintenance cost of carbon brush tracks, system complexity, high material cost of multi-conductor tracks, high cost of data communication subsystems, etc., of the conventional medical systems, and realize the high-performance requirements of non-physical contact synchronous transmission of the power and the data in a novel, reliable and low-cost manner.

[0208] The basic concepts have been described above. Obviously, for those skilled in the art, the above detailed disclosure is only for example and does not constitute a limitation of the present disclosure. Although not explicitly stated herein, those skilled in the art may make various modifications, improvements and amendments to the present disclosure. Such modifications, improvements and amendments are suggested in the present disclosure, so such modifications, improvements and amendments still belong to the spirit and scope of the exemplary embodiments of the present disclosure.

WHAT IS CLAIMED IS:

1. A non-contact transmission system (100), applied to medical system, comprising a stationary segment (120), a rotational segment (130) and a non-contact coupling apparatus (110); wherein a primary side of the non-contact coupling apparatus (110) is connected with the stationary segment (120), a secondary side of the non-contact coupling apparatus (110) is connected with the rotational segment (130), and

the non-contact coupling apparatus (110) is configured to implement transmission of power and signals between the stationary segment (120) and the rotational segment (130).

2. The non-contact transmission system (100) of claim 1, wherein the non-contact coupling apparatus (110) includes at least one pair of coil windings, the at least one pair of coil windings being configured to implement transmission of power and signals between the stationary segment (120) and the rotational segment (130).

3. The non-contact transmission system (100) of claim 2, wherein the at least one pair of coil windings includes:

a first coil winding pair, configured to implement a transmission of power from the stationary segment (120) to the rotational segment (130) to supply power to one or more main power consumption devices of the rotational segment (130) and/or one or more auxiliary power devices of the rotational segment (130);

a second coil winding pair, configured to implement a transmission of one or more control signals from the stationary segment (120) to the rotational segment (130); and

a third coil winding pair, configured to transmit scanning data signals and/or feedback signals from the rotational segment (130) to the stationary segment (120).

4. The non-contact transmission system (100) of claim 2, wherein the at least one pair of coil windings includes:

a first coil winding pair (41), configured to implement a transmission of first power from the stationary segment (120) to the rotational segment (130) to supply power to one or more main power consumption devices of the rotational segment (130);

a second coil winding pair (42), configured to implement a transmission of second power from the stationary segment (120) to the rotational segment (130), and a transmission of one or more control signals from the stationary segment (120) to the rotational segment (130), the second power being configured to supply power to one or more auxiliary power devices of the rotational segment (130); and

a third coil winding pair (43), configured to transmit scanning data signals and/or feedback signals from the rotational segment (130) to the stationary segment (120).

5. The non-contact transmission system (100) of claim 4, wherein the first power is a large-scale

power stream, the second power is a small-scale power stream.

6. The non-contact transmission system (100) of claim 4 or claim 5, wherein:

the stationary segment (120) includes a high-frequency AC voltage output circuit (11), the rotational segment (130) includes a main power output circuit (13);

a first primary coil of the first coil winding pair (41) is connected with the stationary segment (120), a first secondary coil of the first coil winding pair (41) is connected with the rotational segment (130);

the high-frequency AC voltage output circuit (11) is connected with an external power supply (16) and the first primary coil; and

the main power output circuit (13) is connected with the first secondary coil and the one or more main power consumption devices.

7. The non-contact transmission system (100) of any one of claims 4-6, wherein:

the high-frequency AC voltage output circuit (11) includes an isolation transformer (111), a first rectifier and filter (112), and a first inverter (113) connected in sequence; and

the stationary segment (120) further includes a drive circuit controller (14), the drive circuit controller (14) being configured to control a set of power semiconductor switch components of the first inverter (113) to adjust a real-time output voltage of the high-frequency AC voltage output circuit (11).

8. The non-contact transmission system (100) of any one of claims 4-7, wherein

the stationary segment (120) includes a first power line carrier modulation circuit (21), a DC/DC converter (22), and a second inverter (23);

the rotational segment (130) includes a carrier signal extraction and envelope detection demodulation circuit (25);

a second primary coil of the second coil winding pair (42) is connected with the stationary segment (120), a second secondary coil of the second coil winding pair (42) is connected with the rotational segment (130);

the first power line carrier modulation circuit (21) is configured to control a real-time output voltage of the DC/DC converter (22) based on the control signal of the stationary segment (120), the output voltage of the DC/DC converter (22) is transmitted to the second secondary coil through the second primary coil; and

the carrier signal extraction and envelope detection demodulation circuit (25) is configured to extract an envelope from the output voltage received from the second secondary coil and demodulate the envelop into digital signals.

9. The non-contact transmission system (100) of any one of claims 3-8, wherein:

a ratio of winding turns of the first primary coil to the first secondary coil of the first coil winding

pair is 1:1.5;

a ratio of winding turns of the second primary coil to a second secondary coil of the second coil winding pair is 1:1.5; and/or

a ratio of winding turns of the third primary coil to the third secondary coil of the third coil winding pair is 1:1.

10. The non-contact transmission system (100) of any one of claims 3-9, wherein a first distance between the first coil winding pair and the second coil winding pair is greater than a second distance between the second coil winding pair and the third coil winding pair.

11. The non-contact transmission system (100) of any one of claims 2-10, wherein the at least one pair of coil windings include one or more pairs of axially-coupled coil windings and/or one or more pairs of radially-coupled coil windings.

12. The non-contact transmission system (100) of any one of claims 2-11, wherein a spacing between a primary coil and a secondary coil of each pair of the at least one pair of coil windings is within a preset range.

13. The non-contact transmission system (100) of any one of claims 2-12, wherein the non-contact coupling apparatus (110) further includes a U-shaped isolation layer, and the U-shaped isolation layer is configured to wrap non-opposing surfaces of each pair of the at least one pair of coil windings.

14. The non-contact transmission system (100) of any one of claims 2-13, wherein the at least one pair of coil windings implements the transmission of power and signals in a resonant coupling manner.

15. The non-contact transmission system (100) of any one of claims 2-13, wherein the at least one pair of coil windings implements the transmission of power and signals in a non-resonant coupling manner.

16. The non-contact transmission system (100) of any one of claims 2-15, wherein at least one side of the at least one pair of coil windings is connected with a resonant circuit, and the resonant circuit is configured to optimize a resonant frequency of the system.

17. The non-contact transmission system (100) of any one of claims 2-15, wherein a primary coil of the at least one pair of coil windings is connected with a resonant circuit and a secondary coil of the at least one pair of coil windings is connected with another resonant circuit.

18. The non-contact transmission system (100) of any one of claims 1-17, wherein the rotational segment (130) includes a power supply circuit, wherein the power supply circuit is configured to store power converted from thermal energy of the system, and the power is used to be supplied to one or more auxiliary power devices of the rotational segment (130).

19. The non-contact transmission system (100) of any one of claims 1-18, wherein the non-contact coupling apparatus (110) includes at least one capacitive coupling circuit.

20. The non-contact transmission system (100) of claim 19, wherein the non-contact coupling apparatus (110) further includes at least one pair of coil windings.

21. The non-contact transmission system (100) of any one of claims 2-20, wherein:
the rotational segment (130) includes a second power line carrier modulation circuit (32),
stationary segment (120) includes a carrier signal extraction and demodulation circuit (36);
the second power line carrier modulation circuit (32), the carrier signal extraction and demodulation circuit (36), and the third coil winding pair 43 form a data transmission component 3, and the data transmission component 3 is configured to transmit scanning data signals and/or feedback signals from the rotational segment (130) to the stationary segment (120).

22. The non-contact transmission system (100) of any one of claims 1-21, further comprising a collaborative control component (37), wherein the collaborative control component (37) is configured to monitor and control collaborative operation of associated components across the stationary segment (120) and the rotational segment (130).

23. The non-contact transmission system (100) of claim 22, wherein the collaborative control component (37) includes:

a monitoring circuit (371) of the rotational segment (130) and configured to monitor an operation condition of each element of the rotational segment (130); and

a control circuit (372) of the stationary segment (120) and connected with the monitoring circuit (371), and configured to control, based on feedback data from the monitoring circuit (371), the collaborative operation of the associated components across the stationary segment (120) and the rotational segment (130).

24. A medical system, comprising:

a non-contact transmission assembly of the system of any one of claims 1-23.

25. A medical system, comprising:

a fixed mechanism (200);

a rotating mechanism (300), configured to be rotatable relative to the fixed mechanism (200);

an imaging assembly mounted on the rotating mechanism (300) and configured to acquire scanning data signals related with a subject;

a non-contact transmission assembly configured to transmit power to the imaging assembly and transmit the scanning data signals from the imaging assembly to a processor for an image reconstruction in a non-physical contact manner.

26. The medical system of claim 25, wherein a first part of the non-contact transmission assembly is mounted on the fixed mechanism (200) and a second part of the non-contact transmission assembly is mounted on the rotating mechanism (300), wherein the transmission of the power and the scanning data signals between the first part and the second part is implemented in a non-physical contact manner.

27. The medical system of claim 25 or claim 26, wherein the non-contact transmission assembly includes at least one pair of coil windings, each pair of the at least one pair of coil windings are configured to implement a transmission of at least one of the power and the scanning data signals.

28. The medical system of claim 27, each pair of the at least one pair of coil windings are configured to implement a transmission of different types of information, the different types of information including the power, the scanning data signals, control signals, and feedback signals.

29. The medical system of claim 27 or claim 28, each pair of the at least one pair of coil windings include a primary coil and a secondary coil, the primary coil is mounted on the fixed mechanism (200), the secondary coil is mounted on the rotating mechanism (300), and a space is provided between the primary coil and the secondary coil, so as to implement the transmission of at least one of the power, the scanning data signals, control signals and feedback signals.

30. The medical system of claim 29, wherein the primary coil is disposed surrounding the fixed mechanism (200), the secondary coil is disposed surrounding the rotating mechanism (300), and the fixed mechanism (200) and the rotating mechanism (300) are coaxially arranged.

31. The medical system of any one of claims 27-30, wherein the at least one pair of coil windings include one or more pairs of axially-coupled coil windings and/or one or more pairs of radially-coupled coil windings.

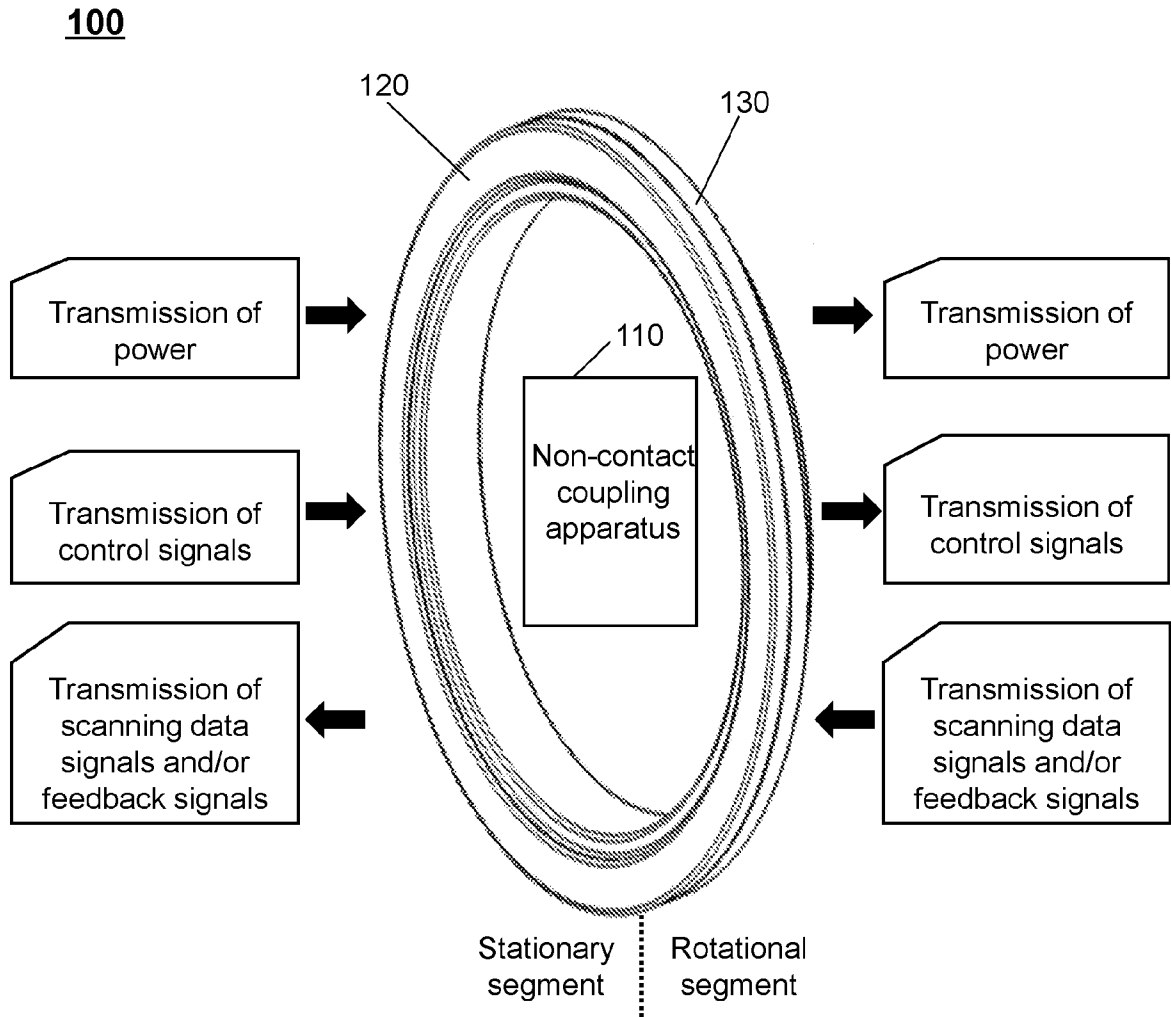

FIG. 1A

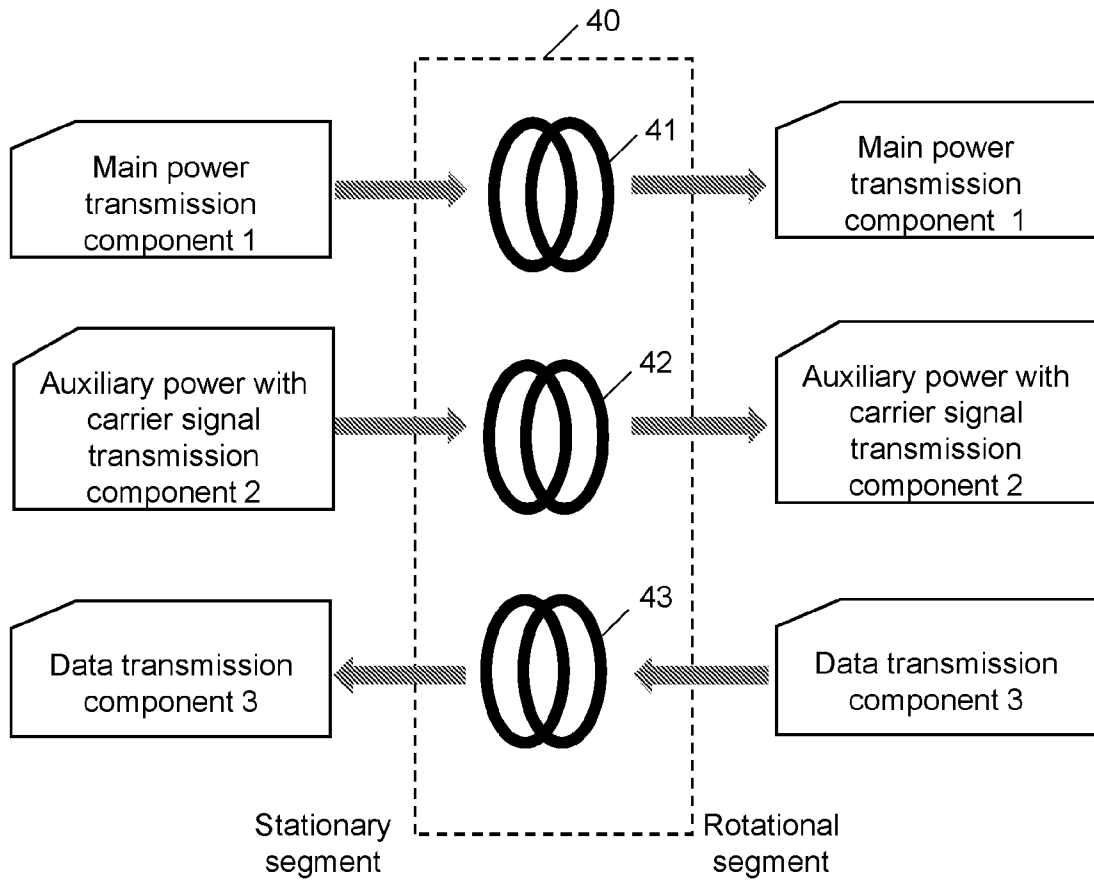

FIG. 1B

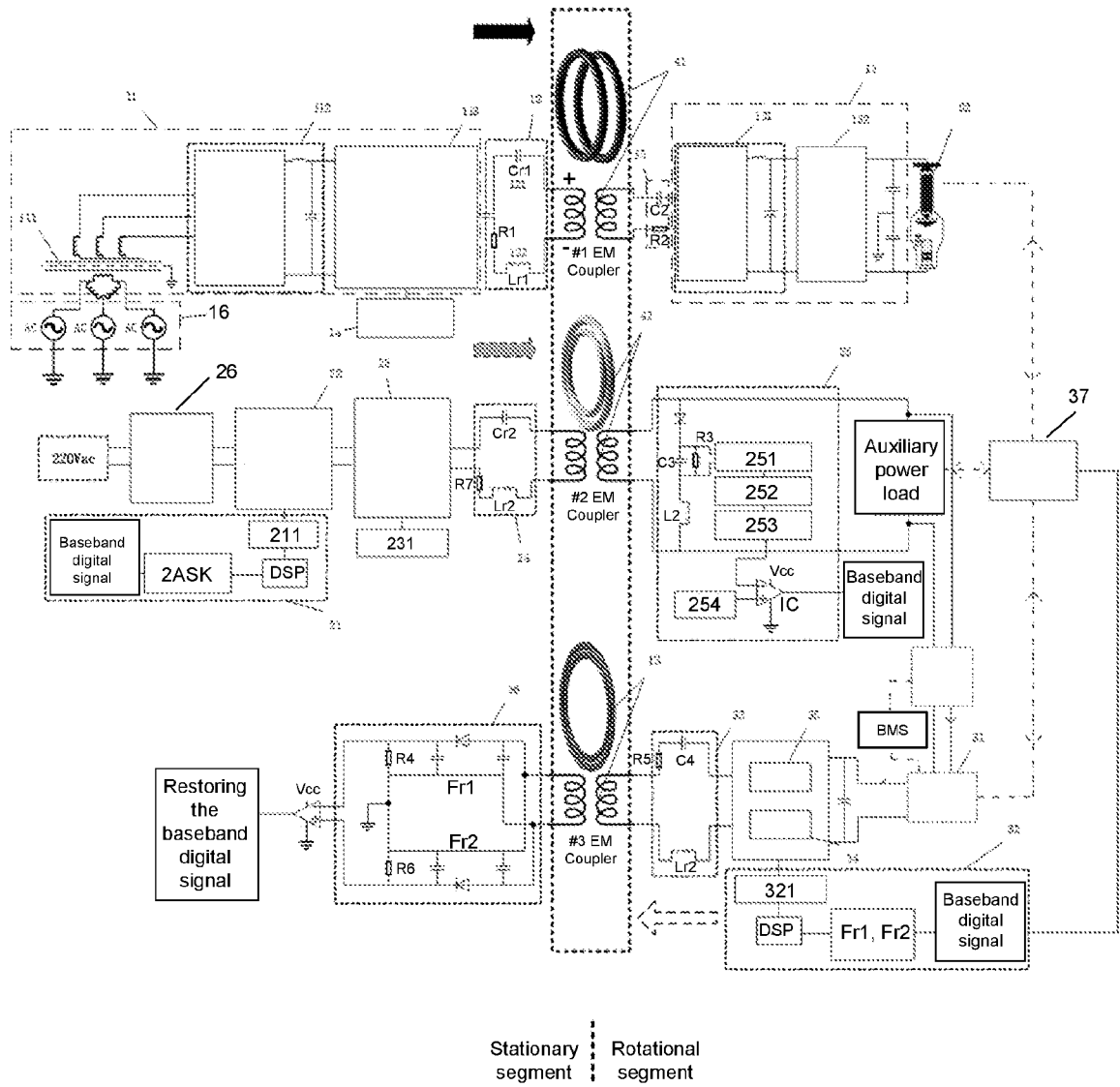

FIG. 2

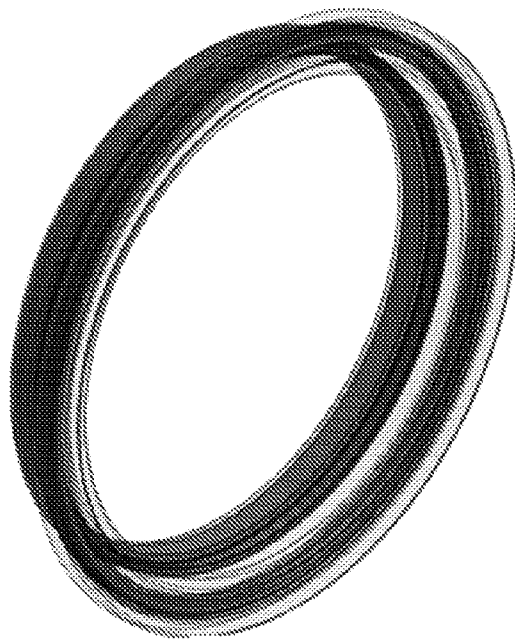

FIG. 3

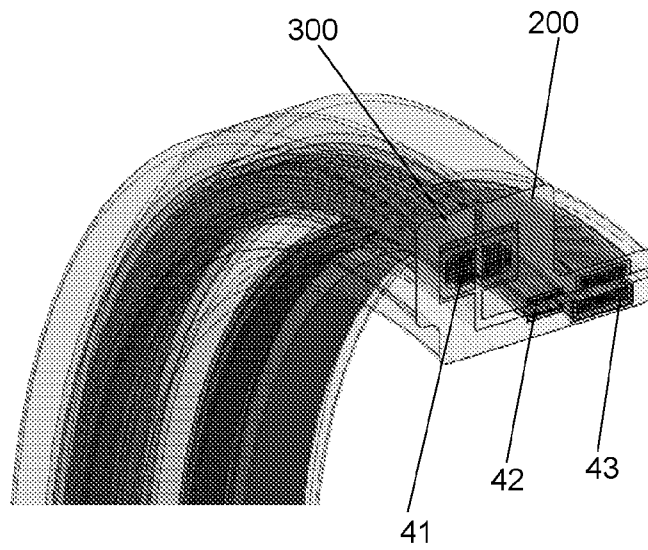

FIG. 4

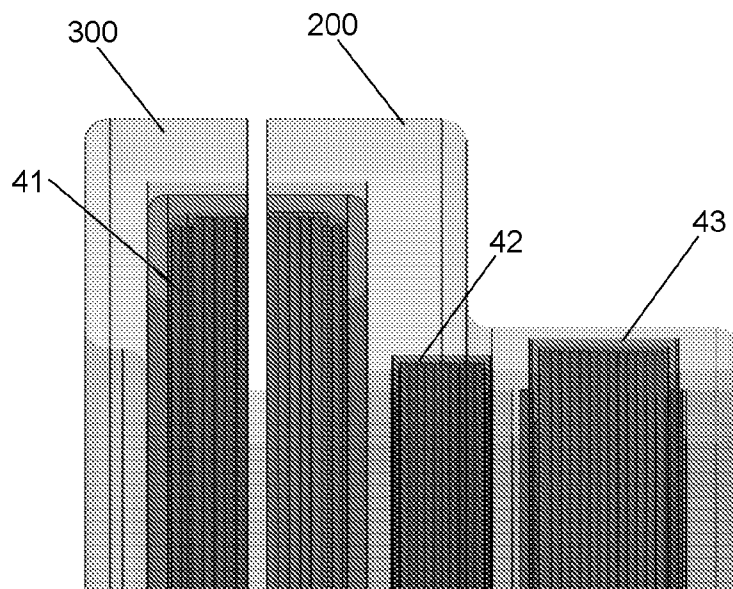

FIG. 5

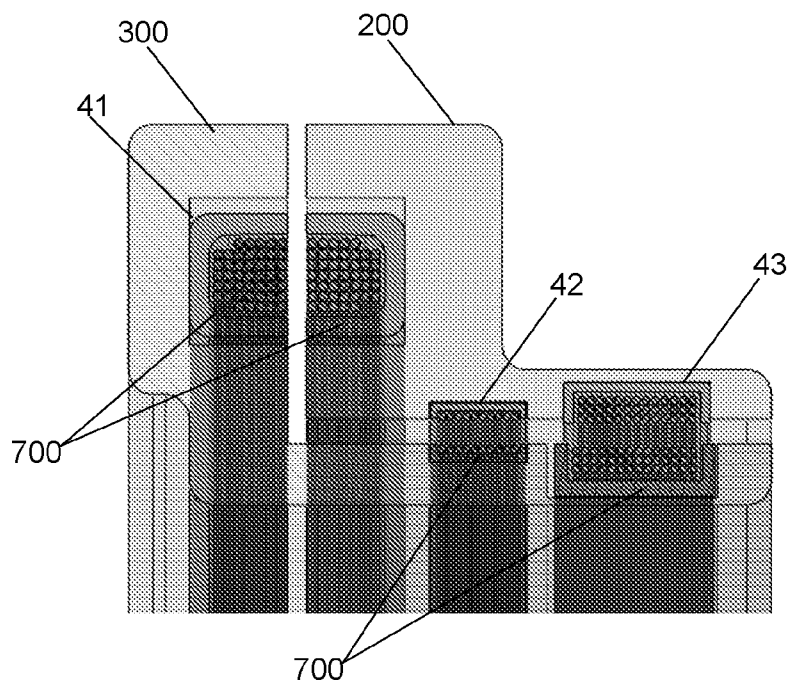

FIG. 6

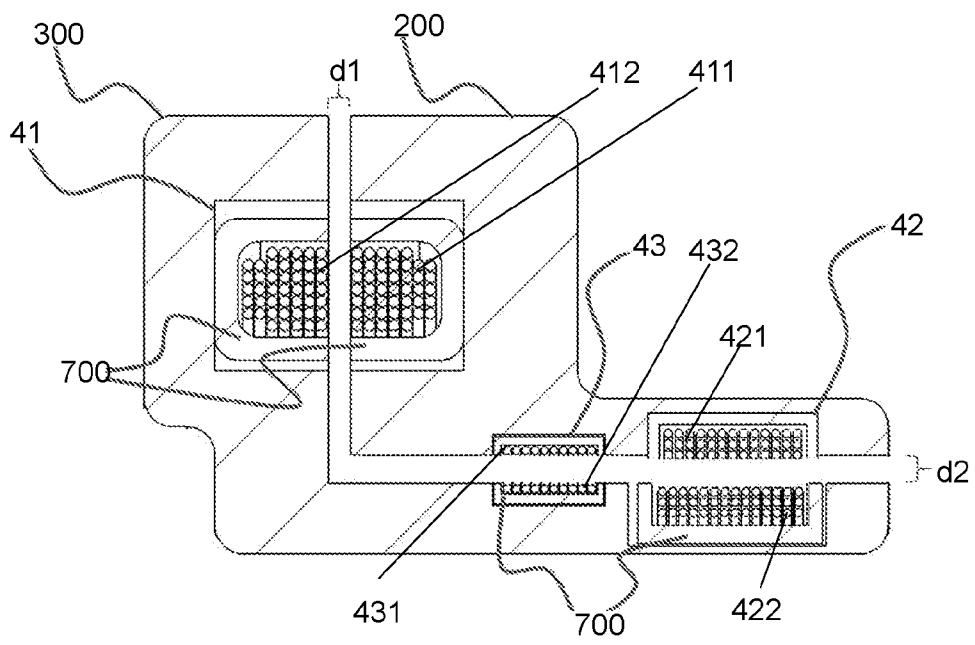

FIG. 7

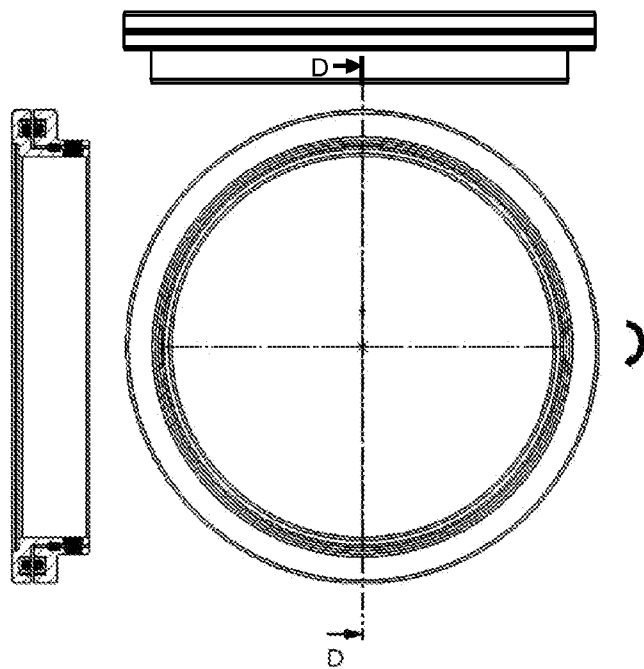

FIG. 8

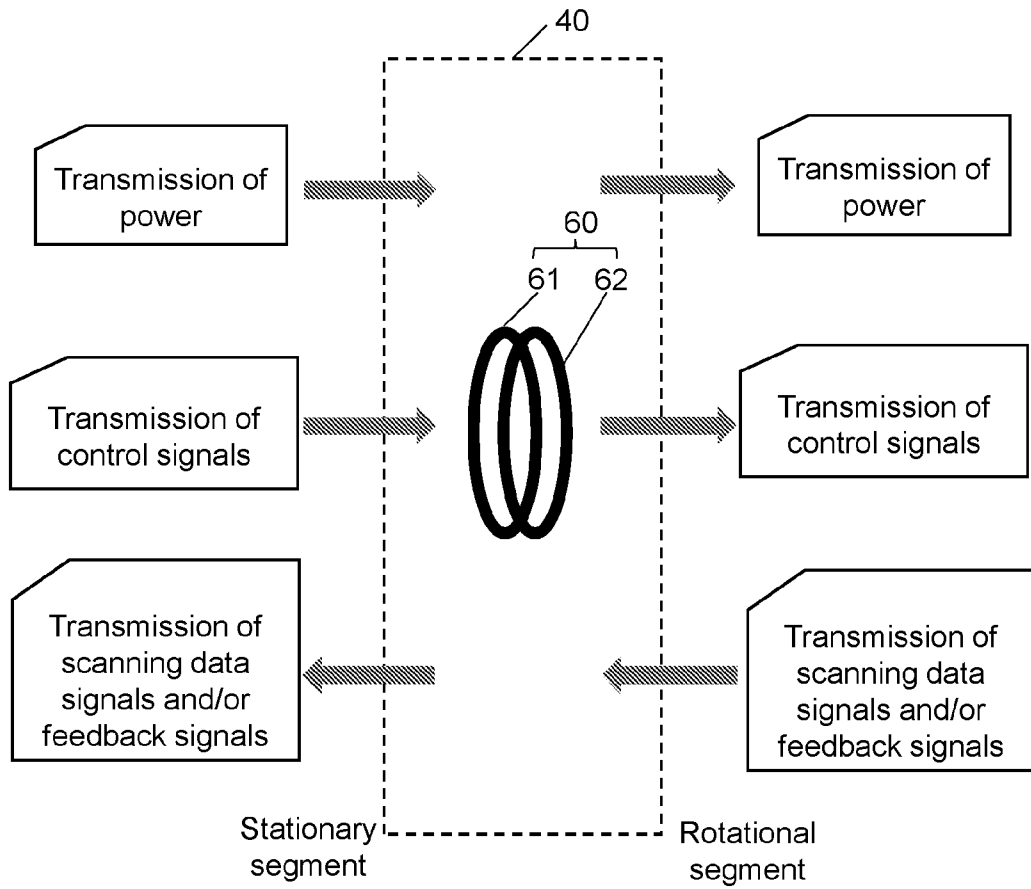

FIG. 9A

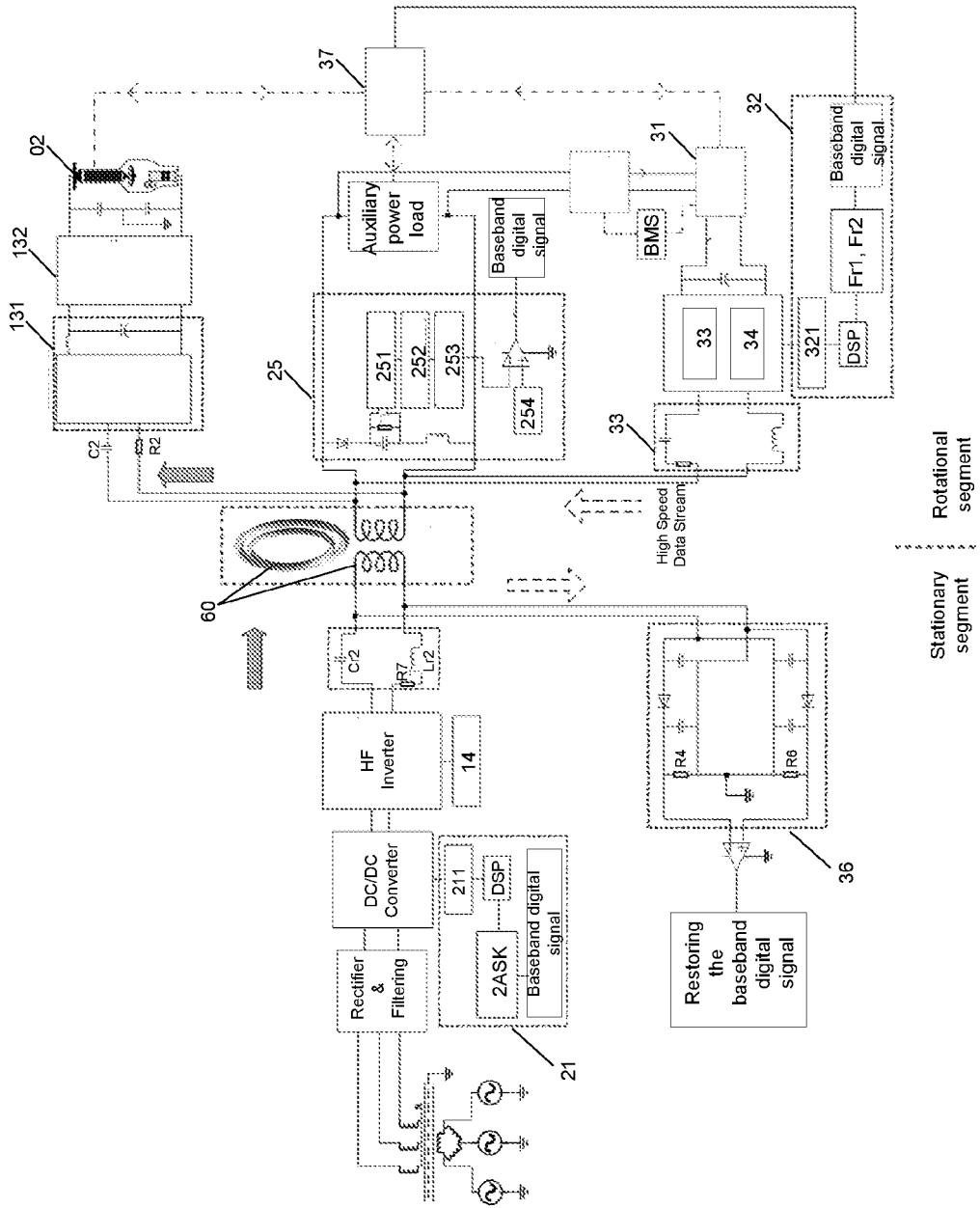

FIG. 9B

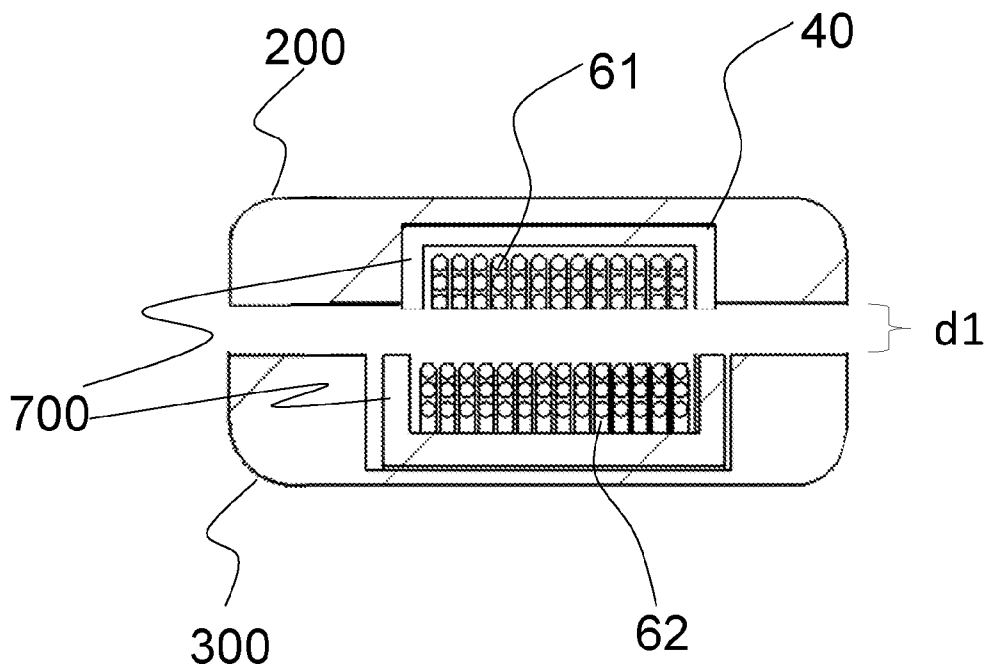

FIG. 9C

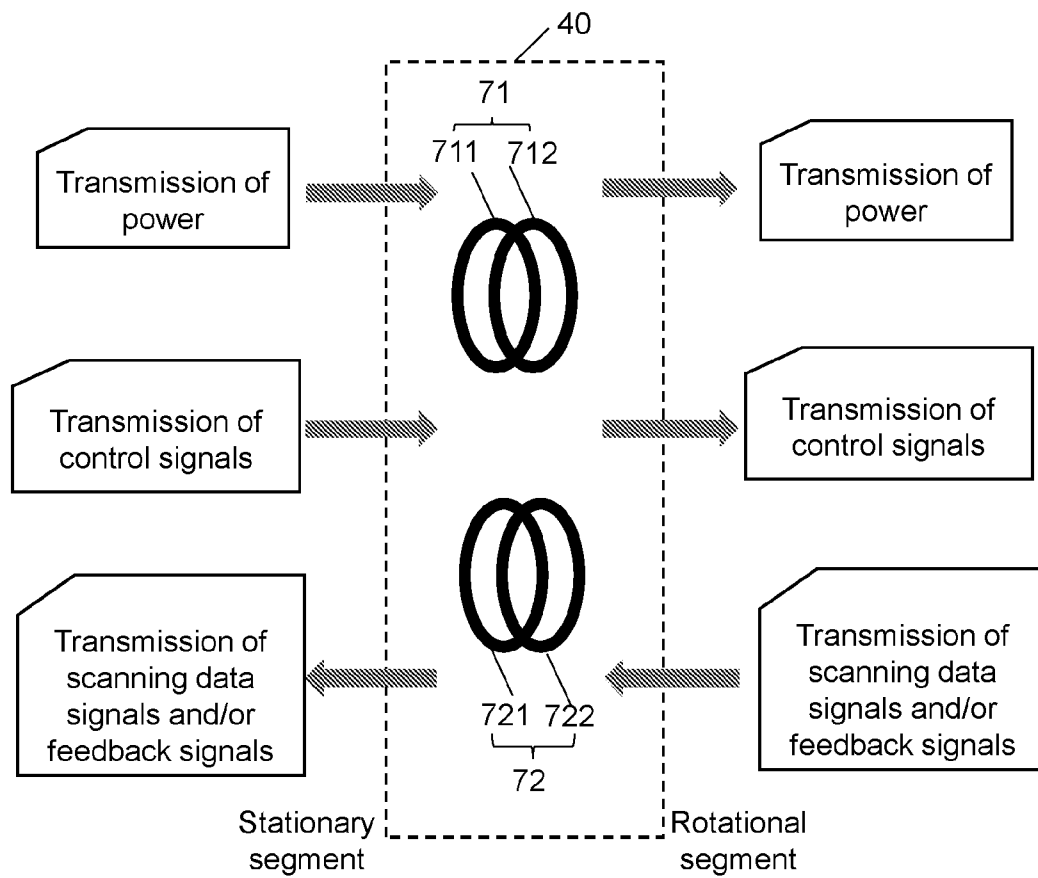

FIG. 9D

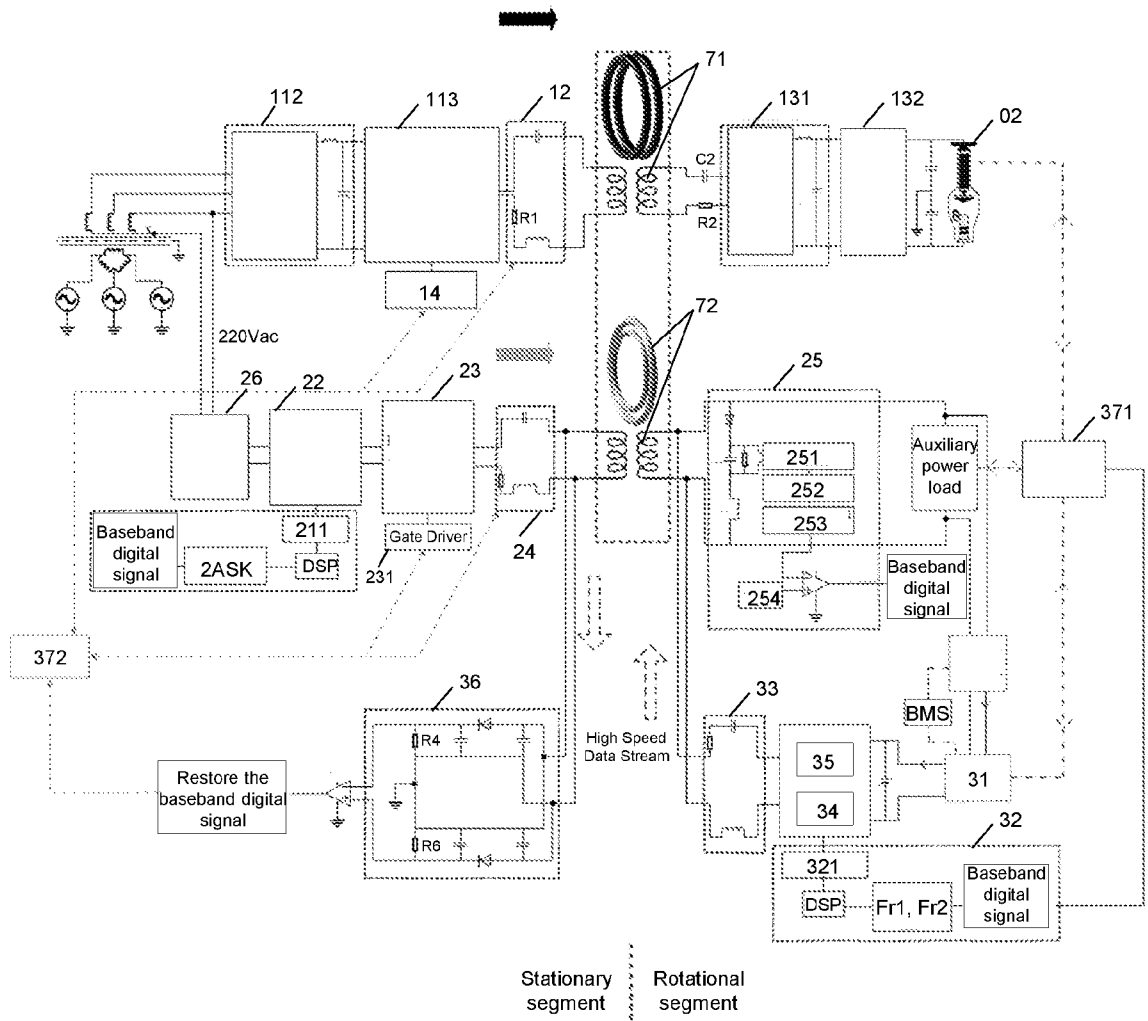

FIG. 9E

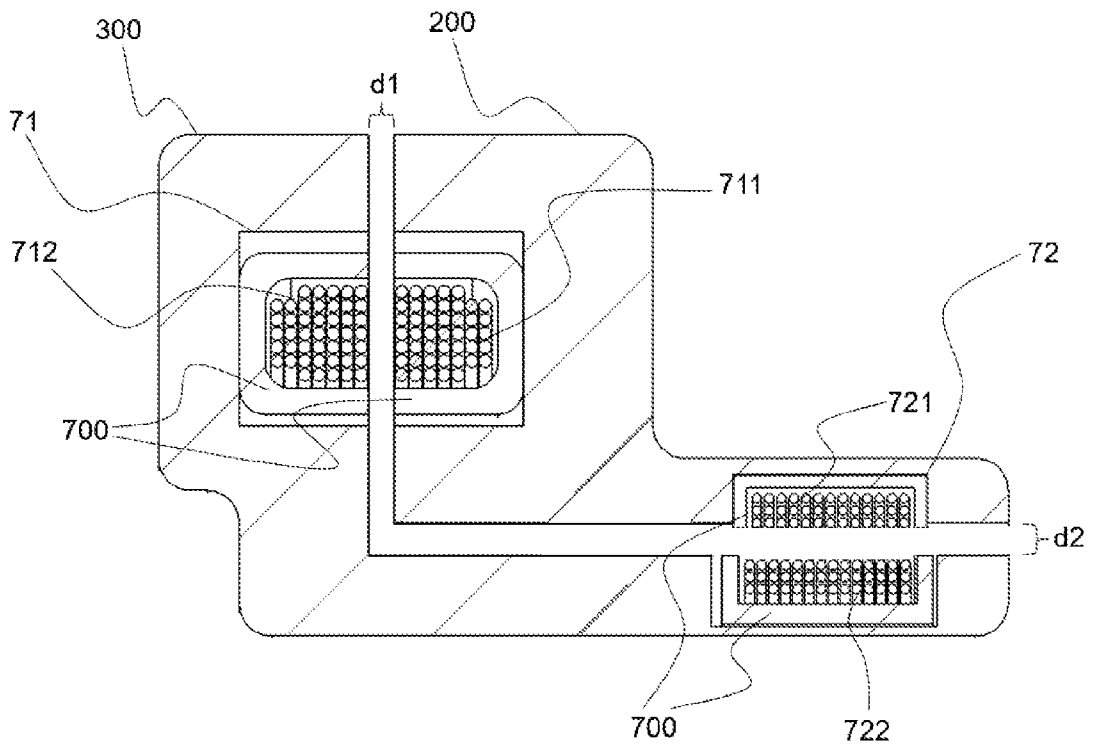

FIG. 9F

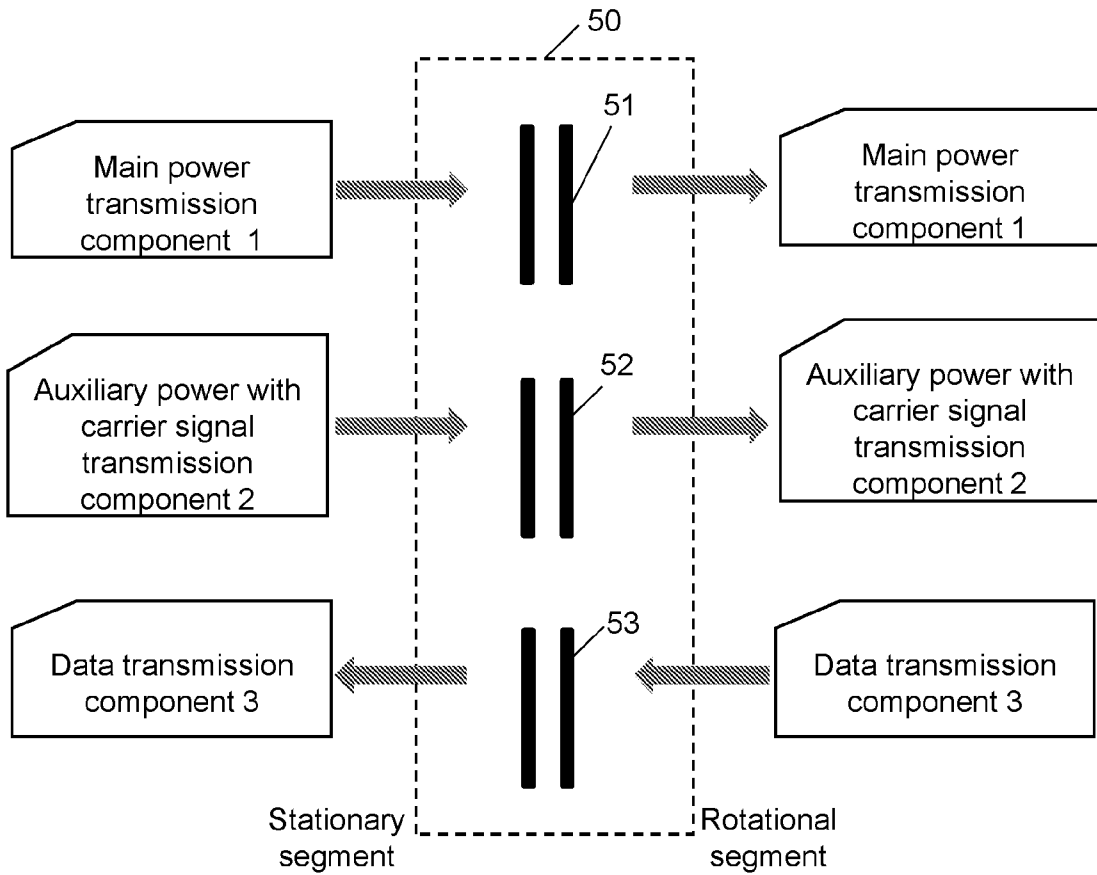

FIG. 9G

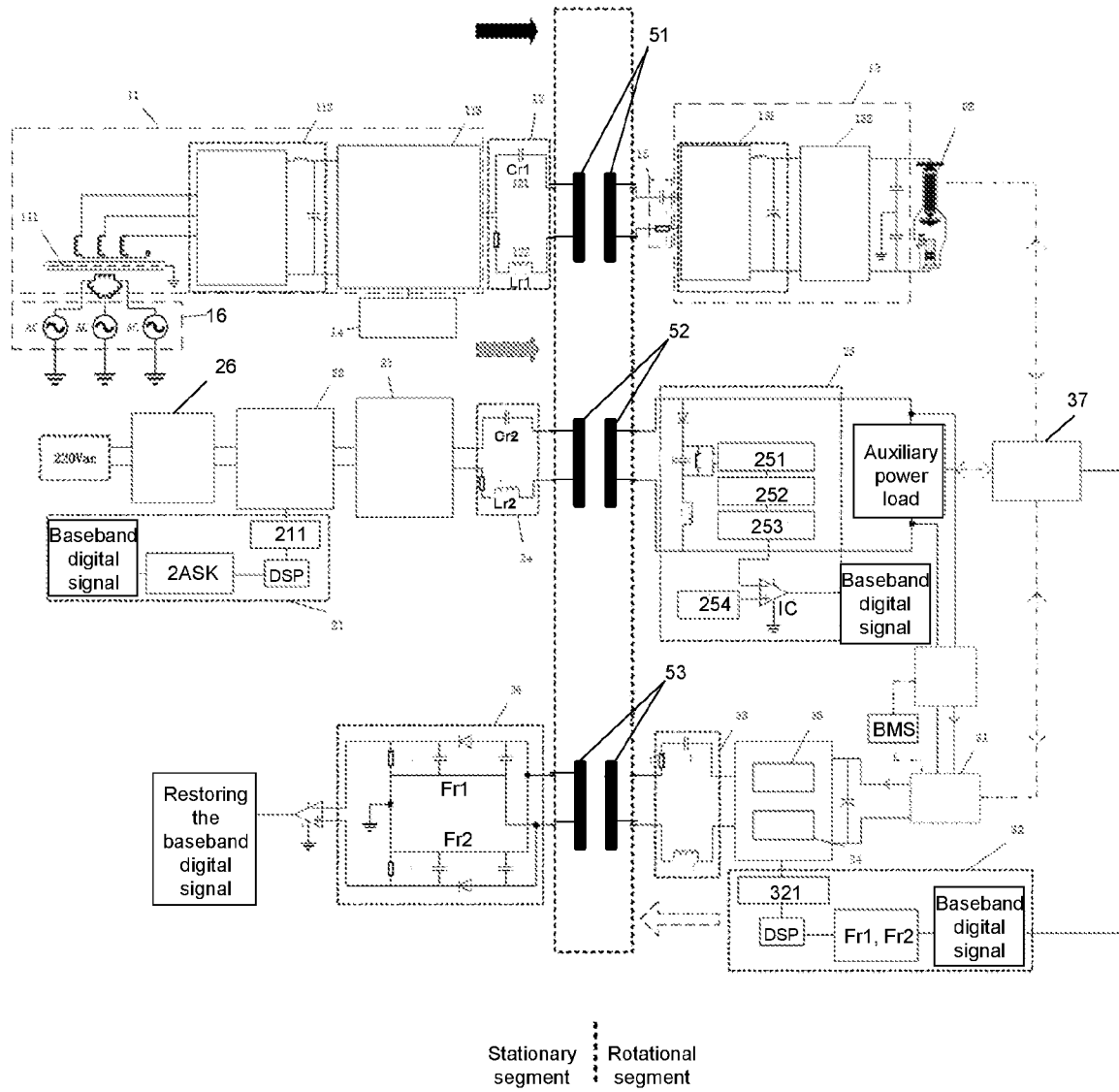

FIG. 10A

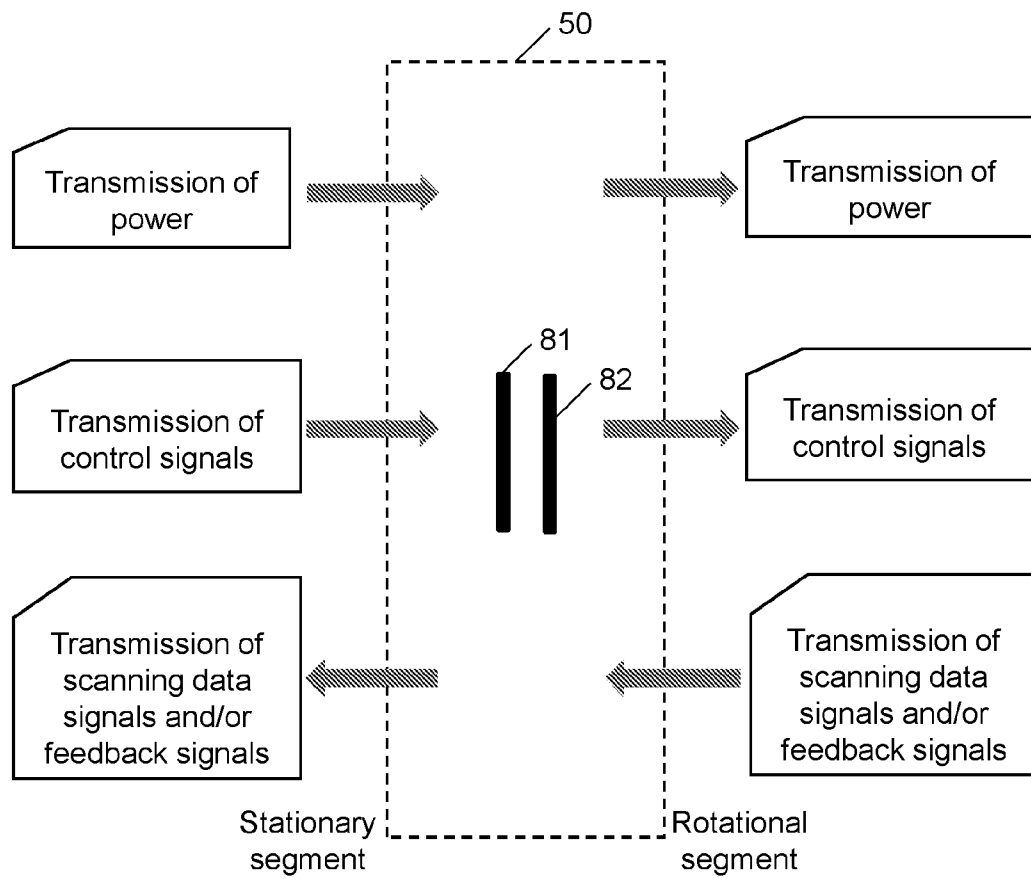

FIG. 10B

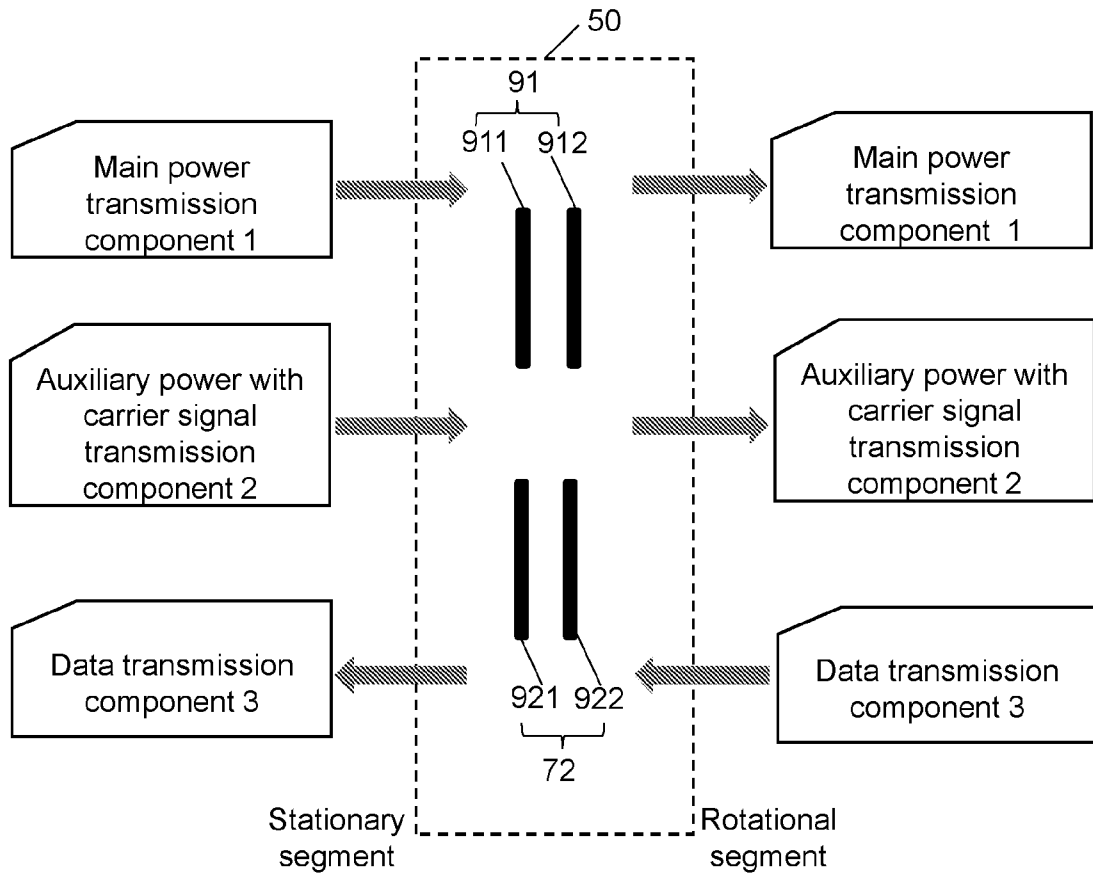

FIG. 10C

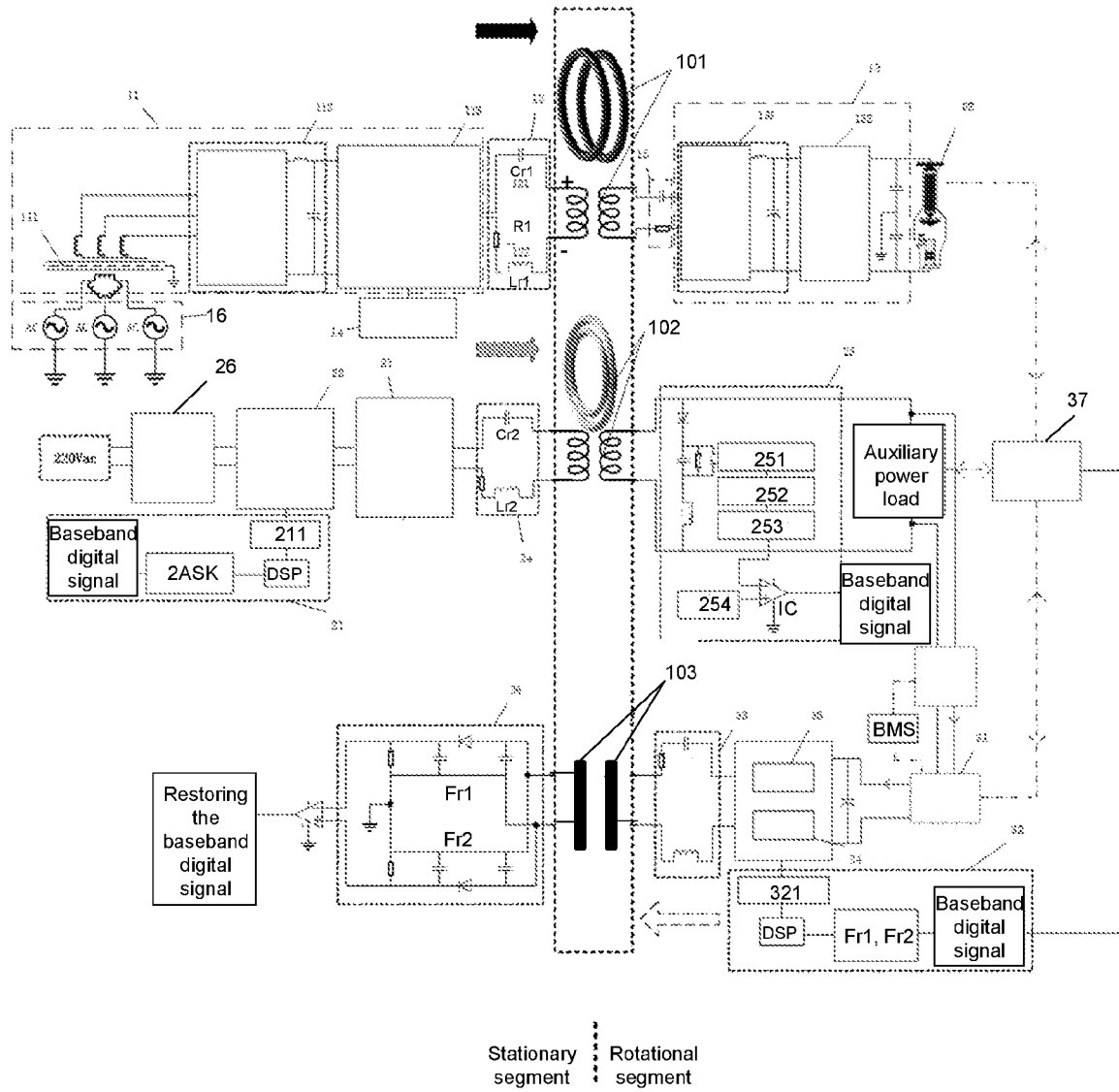

FIG. 11

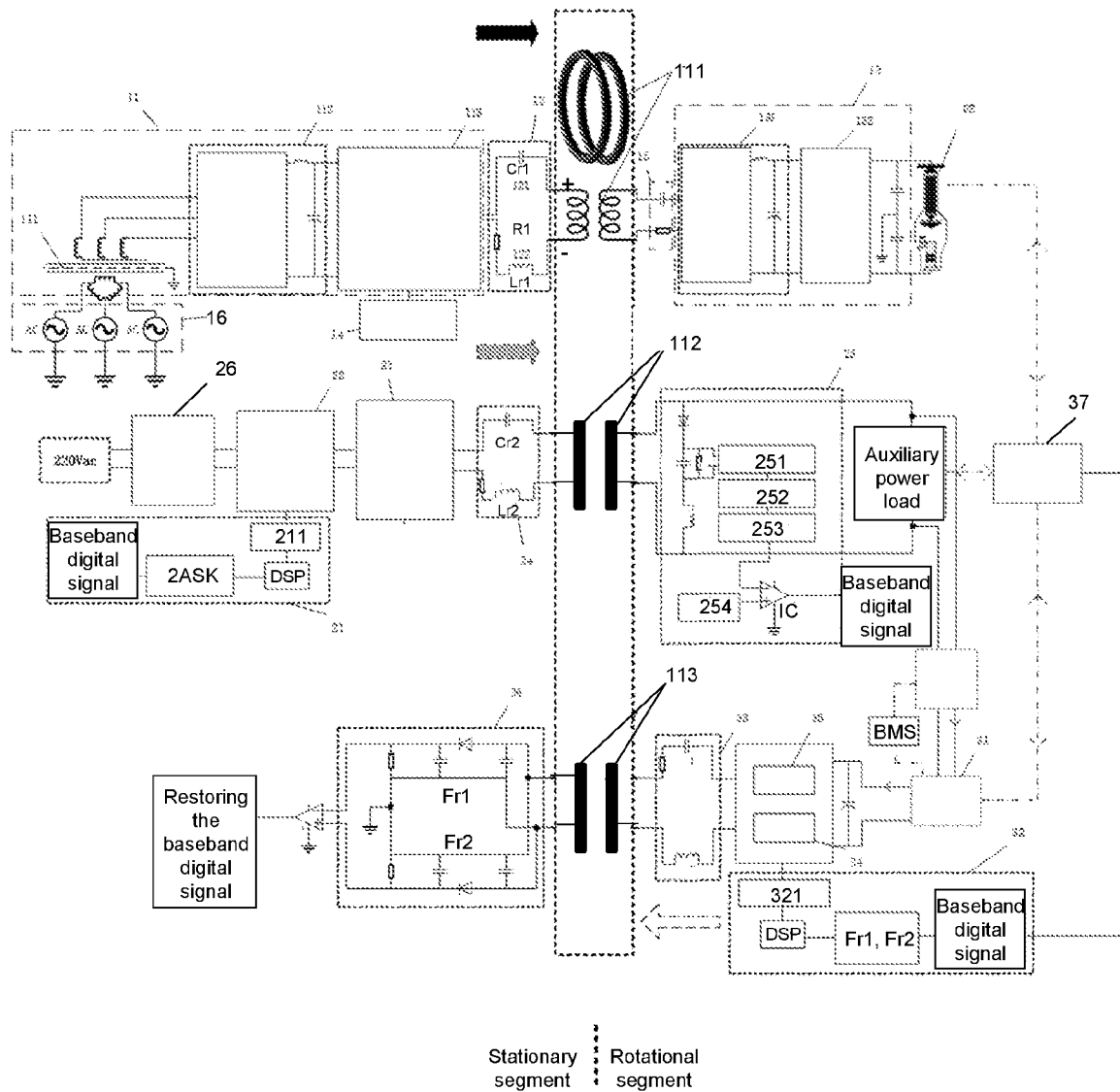

FIG. 12

INTERNATIONAL SEARCH REPORT

International application No.

PCT/CN2024/108101

A. CLASSIFICATION OF SUBJECT MATTER		
H01R39/08(2006.01)i		
According to International Patent Classification (IPC) or to both national classification and IPC		
B. FIELDS SEARCHED		
Minimum documentation searched (classification system followed by classification symbols)		
IPC:H01R		
Documentation searched other than minimum documentation to the extent that such documents are included in the fields searched		
Electronic data base consulted during the international search (name of data base and, where practicable, search terms used)		
CNTXT,ENTXTC,VEN,CJFD: contact+, transmit+, medical, stationary, rotational, power, signal, coil, winding		
C. DOCUMENTS CONSIDERED TO BE RELEVANT		
Category*	Citation of document, with indication, where appropriate, of the relevant passages	Relevant to claim No.
X	CN 101632141 A (ANALOGIC CORP.) 20 January 2010 (2010-01-20) description, paragraphs 23-77 and figures 1-11	1-31
PX	CN 116722413 A (SHANGHAI UNITED IMAGING HEALTHCARE CO.) 08 September 2023 (2023-09-08) description, paragraphs 4-91 and figures 1-8	1-31
A	CN 101026033 A (GENERAL ELECTRIC CO.) 29 August 2007 (2007-08-29) the whole document	1-31
A	CN 107086117 A (MORPHO DETECTION L.L.C.) 22 August 2017 (2017-08-22) the whole document	1-31
A	CN 1886810 A (SCHLEIFRING & APP G.M.B.H.) 27 December 2006 (2006-12-27) the whole document	1-31
A	US 2001008552 A1 (HARADA, T. et al.) 19 July 2001 (2001-07-19) the whole document	1-31
A	US 2005226380 A1 (GENERAL ELECTRIC CO.) 13 October 2005 (2005-10-13) the whole document	1-31
<input type="checkbox"/> Further documents are listed in the continuation of Box C. <input checked="" type="checkbox"/> See patent family annex.		
* Special categories of cited documents: "A" document defining the general state of the art which is not considered to be of particular relevance "D" document cited by the applicant in the international application "E" earlier application or patent but published on or after the international filing date "L" document which may throw doubts on priority claim(s) or which is cited to establish the publication date of another citation or other special reason (as specified) "O" document referring to an oral disclosure, use, exhibition or other means "P" document published prior to the international filing date but later than the priority date claimed "T" later document published after the international filing date or priority date and not in conflict with the application but cited to understand the principle or theory underlying the invention "X" document of particular relevance; the claimed invention cannot be considered novel or cannot be considered to involve an inventive step when the document is taken alone "Y" document of particular relevance; the claimed invention cannot be considered to involve an inventive step when the document is combined with one or more other such documents, such combination being obvious to a person skilled in the art "&" document member of the same patent family		
Date of the actual completion of the international search		Date of mailing of the international search report
11 October 2024		21 October 2024
Name and mailing address of the ISA/CN		Authorized officer
CHINA NATIONAL INTELLECTUAL PROPERTY ADMINISTRATION 6, Xitucheng Rd., Jimen Bridge, Haidian District, Beijing 100088, China		LI, Li Telephone No. (+86) 010-53961160

INTERNATIONAL SEARCH REPORT
Information on patent family members

International application No.

PCT/CN2024/108101

Patent document cited in search report			Publication date (day/month/year)	Patent family member(s)			Publication date (day/month/year)				
CN	101632141	A	20 January 2010	WO	2008079870	A2	03 July 2008				
				WO	2008079870	A3	16 October 2008				
				EP	2492932	A1	29 August 2012				
				EP	2492932	B1	30 July 2014				
				US	2014098929	A1	10 April 2014				
				US	9912254	B2	06 March 2018				
				EP	2104940	A2	30 September 2009				
				EP	2104940	B1	04 March 2015				
				EP	2533258	A2	12 December 2012				
				EP	2533258	A3	27 March 2013				
				EP	2533258	B1	05 November 2014				
				EP	2806437	A1	26 November 2014				
				EP	2806437	B1	28 November 2018				
				EP	2490232	A1	22 August 2012				
				EP	2490232	B1	17 September 2014				
				CA	2673298	A1	03 July 2008				
				CA	2673298	C	17 May 2016				
				US	2010066340	A1	18 March 2010				
				US	8581437	B2	12 November 2013				
				JP	2010515407	A	06 May 2010				
JP	5480630	B2	23 April 2014								
-----	-----	-----	-----	-----	-----	-----	-----				
CN	116722413	A	08 September 2023	None							
CN	101026033	A	29 August 2007	JP	2007165876	A	28 June 2007				
				JP	4977453	B2	18 July 2012				
				DE	102006057150	A1	19 July 2007				
				US	7197113	B1	27 March 2007				
-----	-----	-----	-----	-----	-----	-----	-----				
CN	107086117	A	22 August 2017	EP	3214628	A2	06 September 2017				
				EP	3214628	A3	13 December 2017				
				EP	3214628	B1	29 April 2020				
				US	2017238405	A1	17 August 2017				
				US	10034361	B2	24 July 2018				
				CA	2957460	A1	15 August 2017				
				CA	2957460	C	12 March 2024				
				PL	3214628	T3	16 November 2020				
-----	-----	-----	-----	-----	-----	-----	-----				
CN	1886810	A	27 December 2006	WO	2005064625	A1	14 July 2005				
				DE	50312784	D1	15 July 2010				
				AU	2003293734	A1	21 July 2005				
				ATE	470229	T1	15 June 2010				
				EP	1690268	A1	16 August 2006				
				EP	1690268	B1	02 June 2010				
				US	2007195924	A1	23 August 2007				
				US	7634046	B2	15 December 2009				
				-----	-----	-----	-----	-----	-----	-----	-----
				US	2001008552	A1	19 July 2001	US	6674836	B2	06 January 2004
JP	2001269330	A	02 October 2001								
-----	-----	-----	-----	-----	-----	-----	-----				
US	2005226380	A1	13 October 2005	US	7054411	B2	30 May 2006				
				JP	2006296944	A	02 November 2006				
				DE	102005020186	A1	09 November 2006				
-----	-----	-----	-----	-----	-----	-----	-----				