

(19)



(11)

EP 4 239 278 B1

(12)

EUROPEAN PATENT SPECIFICATION

(45) Date of publication and mention of the grant of the patent:
29.01.2025 Bulletin 2025/05

(21) Application number: **20958925.8**

(22) Date of filing: **29.10.2020**

(51) International Patent Classification (IPC):
F42B 3/12 ^(2006.01) **F42D 1/055** ^(2006.01)

(52) Cooperative Patent Classification (CPC):
F42B 3/122; F42B 3/124; F42B 3/125; F42B 3/128;
F42D 1/055

(86) International application number:
PCT/CL2020/050144

(87) International publication number:
WO 2022/087756 (05.05.2022 Gazette 2022/18)

(54) PROGRAMMABLE NON-EXPLOSIVE ELECTRONIC INITIATOR FOR ROCK BLASTING, AND EXOTHERMIC REACTION AND TESTING PROCESS OF THE INITIATOR

PROGRAMMIERBARER NICHTEXPLOSIVER ELEKTRONISCHER ZÜNDER ZUM SPRENGEN VON GESTEIN SOWIE EXOTHERME REAKTION UND PRÜFVERFAHREN FÜR DEN ZÜNDER
INITIATEUR ÉLECTRONIQUE PROGRAMMABLE NON EXPLOSIF POUR DYNAMITAGE DE ROCHE, ET PROCÉDÉ DE TEST ET DE RÉACTION EXOTHERMIQUE DE L'INITIATEUR

(84) Designated Contracting States:
AL AT BE BG CH CY CZ DE DK EE ES FI FR GB GR HR HU IE IS IT LI LT LU LV MC MK MT NL NO PL PT RO RS SE SI SK SM TR

(43) Date of publication of application:
06.09.2023 Bulletin 2023/36

(73) Proprietor: **COMERCIALIZADORA EXOBLAST CHILE SPA**
2002, Ñuñoa. Santiago (CL)

(72) Inventor: **ABARCA VARGAS, Eduardo Alfredo Ñuñoa. Santiago (CL)**

(74) Representative: **Maldonado Jordan, Julia Linares, 7 - 3 46018 Valencia (ES)**

(56) References cited:
EP-B1- 1 306 642 EP-B1- 3 051 248
CA-C- 2 802 888 US-A1- 2005 034 624
US-A1- 2018 371 859

- **No further relevant documents disclosed**

EP 4 239 278 B1

Note: Within nine months of the publication of the mention of the grant of the European patent in the European Patent Bulletin, any person may give notice to the European Patent Office of opposition to that patent, in accordance with the Implementing Regulations. Notice of opposition shall not be deemed to have been filed until the opposition fee has been paid. (Art. 99(1) European Patent Convention).

Description**Technical field of the development**

5 **[0001]** This development aims to provide a non-explosive (deflagrating) programmable electronic initiator for a rapidly expanding metallic mixture (such as plasma and/or explosives of different category), which seeks to provide a solution to the following technical problems in rock fragmentation; to achieve the high temperature necessary to activate a rapidly expanding metallic mixture with a very low voltage requirement; to improve the rates of non-activated charges (left behind firings) with an effective test system; to provide work continuity, increase productivity and safety in the processes related to
10 rock fragmentation with a programmed delay system in each initiator.

Description of the prior art

15 **[0002]** Since the invention of dynamite, we no longer detonate explosives with fire, but instead by percussion, triggered by the prior detonation of a high explosive (shock wave). These methods are what we call "initiation systems".

[0003] In 1863 Alfred Nobel patented his first initiator, consisting of a piece of wood filled with black powder. He later invented a device with a copper capsule system inside which contained mercury fulminate. Afterwards, an extensive range of detonators were developed, whose characteristics varied according to the circumstances in which they were to be applied (mining, quarrying, construction) and the type of dynamite with which they were to be used.

20 **[0004]** Another initiation system is the safety wick or slow wick system This consists of black powder wrapped in textile yarns, with a braiding machine, then waterproofed with a layer of asphalt and covered with a new layer of textile or wax. From 1936 to date, a detonating cord has been used, which is a flexible, waterproof rope containing explosive inside, originally trinitrotoluene (TNT) and penthrite.

25 **[0005]** The mass application of explosives in the more than 140-year history of the industry has been due to their low cost and accessibility. There have been technological advances in mixing and detonators. Currently, the explosive technology used consists of the use of a blasting agent, "Anfo" (Ammonium Nitrate - Fuel Oil), a mixture of ammonium nitrate and petroleum that does not produce toxic gases and has an adequate power according to the type of rock to be fragmented.

30 **[0006]** A technical problem with rock blasting is its effect on the rock in the vicinity, as it can produce intense fragmentation and disruption of the integrity of the rock in the surrounding area if the blasting or drilling systems are incorrect. The damage would be greater if the blasting energy were transmitted to a more remote area, destabilizing the mine structures.

35 **[0007]** The results of a blast depend on factors such as: rock type, stress regime, structural geology, and the presence of water. Appropriate measures to minimize blast damage include: proper choice of explosive, use of perimeter blasting techniques such as pre-division blasting (closely spaced parallel holes that define the perimeter of the excavation), decoupling charges (the diameter of the explosive is smaller than that of the blast hole), delay time and stop drills.

40 **[0008]** Some references with respect to electronic detonator developments may include European patent DE 102005052578.4 describing a method and a system for assigning a delay time to an electronic delay detonator, where the detonator includes an information register (24), in which the desired delay time value, supplied by the controller, is recorded, where subsequently, during a predetermined time period (t), the contents of the information register (24) are repetitively added to a counter register (26), where the contents are accumulated, where after a division of the contents of the counter register over the calibration time, the contents of the counter register (26) are subsequently counted backwards using the same oscillator (18) controlling the accumulation process. The present invention allows the value of the delay time supplied by the controller to be accurately matched, using an oscillator (18) with low precision and no feedback from the trigger (12) to the controller.

45 **[0009]** Another development with respect to electronic detonators refers to US Patent US 61/108,277 describing a detonator that incorporates a high voltage switch, an initiator and an initiation pellet, with the detonator also comprising a low- to high-voltage detonation group connected to the switch and the initiator, such that the detonator includes a high voltage power source and an initiator in one integrated package. The detonator may also include a power cord and communications devices, a microprocessor, tracking and/or locating technologies, such as rfid, gps, etc., and a pellet of an explosive or combination of explosives. The combination explosive pellet has a first explosive with a first-impact energy, and a secondary high explosive in the exit pellet with a second impact energy greater than the impact energy of the first explosive. Systems for quick and easy deployment of one or more detonators in the field are also provided.

50 **[0010]** Within the large universe of patents on electronic detonators, we can mention patents EP1105693 / WO0009967 describing a method and apparatus for setting up a blasting arrangement by loading at least one detonator in each of the numerous blasting holes, placing explosive material in each blasting hole, connecting to a trunk line a control unit with a power source incapable of firing the detonators, sequentially connecting the detonators -using respective bypass lines- to the trunk line and leaving each detonator connected to the trunk line. The device further includes means for receiving and storing in memory the identity data of each detonator, means for causing a signal to be generated to test the integrity of the
55

detonator/trunk line connection and the functionality of the detonator, and being able to assign a predetermined time delay to each detonator to be stored in memory.

[0011] One may also mention patents E12706936 / EP2678633 / ES2540573T3, which disclose an explosive detonator system for detonating a charge of explosive whereby, during use, arranged in a detonation relation, the detonator system comprising a detonator, which includes a detonator capsule; a detonation circuit within the detonator capsule, including the detonation circuit comprising a conductive path; an igniter head within the detonator capsule, the igniter head comprising at least two spatially separated conductive electrodes and a resistive bridge connecting the space between the electrodes, integrating the igniter head with the detonation circuit such that the conductive path passes along both the electrodes and the resistive bridge; included in a charge signal communicated to the detonator during use, such that exposure to the charge property charges the voltage source, thereby rendering the voltage source capable of causing a potential difference between the electrodes at least to equal the breakdown voltage of the resistive bridge; and a shock tube which is provided, during use, in close proximity of initiation to the detonator and is capable of providing a shock signal as at least part of the charge signal, the shock tube comprising a hollow elongated body, within which is provided a shock tube explosive, whose detonation provides the shock signal, wherein the charging property includes at least a charging light pulse and, optionally, a charging temperature, a charging pressure and/or a charging radio frequency of the charging signal, making the chargeable voltage source therefore sensitive to the charging light pulse and, optionally, to either the charging temperature, the charging pressure and the charging radio frequency, or their conjunction; and whereby a photoluminescent chemical is provided within the hollow elongated body supplying the charging light pulse.

[0012] On the other hand, patent US6173651 B1 discloses a detonator control method equipped with an electronic ignition module. Each module is associated with specific parameters including at least one identification parameter and a burst delay time, and includes a trigger capacitor and a rudimentary internal clock. The modules can communicate with a trigger control unit equipped with a reference time base. Identification parameters are stored in the modules via a programming unit; specific parameters are stored in the trigger control unit; for each successive module, their internal clock is calibrated by the trigger control unit and the associated delay time is sent to the module; the modules are commanded to charge the trigger capacitors and a trigger command is sent to the modules via the trigger control unit, which triggers an eventual reset of the internal clocks as well as a trigger sequence.

[0013] A second US patent, US4674047 A1 discloses a detonation system for use with electric power supply that has a user-operable firing console for selectively transmitting unit identification information, firing delay time information, and selections from a set of commands including Exit, Delay, Fire (Time), Abort, Power On (Arm), Entry, and Store. The console displays the responses or digested information from the responses of the electrical delay triggers to the commands. Detonators have an explosive, a capacitor to store energy from the supply to activate the explosive, a circuit to charge the capacitor from the supply and transfer energy from the capacitor to the explosive in response to first and second signals caused by the commands. Each detonator can be programmed with a unique identification number and delay time. The time base for each detonator can be compensated, avoiding time base errors preventing a correct delay. The security code circuits and software are described in such a way that each detonator can only be activated by authorized users.

[0014] However, their use has not been without problems; the vibration caused by the explosives restricts their use in urban areas and damages the environment, causing the risk of scour and forcing the company to incur the cost of repairing the surrounding geology. On the other hand, in commercial mining operations, the conventional explosive fragmentation method results in a jumbled mixture of inert material with the ore, which must be removed from the mine, crushed and processed; this, added to the depletion and lowering of ore grades worldwide, has implied an increase in tailings removal, and the way in which this is treated is key, where stages such as fragmentation can affect a company's productivity and profitability. The importance of the concept of controlled fragmentation in mining transpires from this.

[0015] The use of alternative fast expanding metallic mixtures, which do not contain dynamite, dates from after World War II, and the technological advances are mainly reflected in the Korean patent No. 10-0213577, consisting of a fast expanding metallic mixture with ignition points up to 700°C, with applications in the mining and civil works industry and whose main characteristic is a higher and shorter (time) expansion force when compared to dynamite.

[0016] The fast-expanding metallic mixture corresponds to a chemical mixture composed of metal salts and powders, available in multiple formulations on the market, according to the following examples:



Patent No. 10-0213577

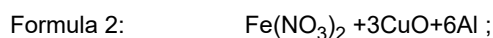

Patent No. 10-0213577

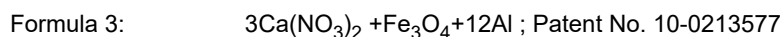

Formula 4: $\text{Fe}_2\text{O}_3+4\text{Na}_2\text{O}+\text{BaCO}_3+4\text{Mg}$;

Patent No. 10-0213577

5

Formula 5: $\text{Fe}_2\text{O}_3+\text{NaSO}_4+4\text{Al}$;

Patent No. 10-0213577

10

Formula 6: $2\text{Na}_2\text{O}+\text{Fe}_2\text{O}_3+3\text{CuO}+2\text{Al}$;

Patent No. 10-0213577

15

Formula 7: $2\text{NaClO}_4+2\text{CuO}+2\text{Al}$;

Patent No.10-0213577

[0017] A formula, as identified in Formula 1 above, subjected to temperatures of 1,500°C, (Note that the ignition temperature varies according to the ratios of salt and metal powder mixture in each Formula), triggers the following thermochemical reaction of its components:

20

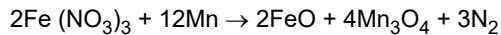

[0018] The metal salt allows the oxidation of the metal powder, the heat generated in the oxidation process of extremely high temperatures (3,000°C - 30,000°C) is caused instantaneously, releasing a large amount of thermal energy, converting the iron (Fe) and manganese oxide (Mn₃O₄) products into vaporized gases that expand rapidly; the expanded product by vaporization is changed to a solid state, thus stopping the expansion reaction. When the outcome occurs in a confined space, the release of expansive energy is what finally allows the rock to fracture due to the high pressures reached (5,000 - 20,000 Atm).

25

[0019] As in the formula stated above (Formula 1), metal nitrates are the most preferable; however, a rapidly expanding metal mixture can also be composed of other metal salts such as: metal oxides, metal hydroxides, metal carbonates, metal sulfates and metal perchlorates. This metallic salt can be used on its own or combined with others. In particular, metal nitrates can be further added with at least one metal salt selected from metal oxides, metal hydroxides, sulfates and metal perchlorates, to control the temperature required for the onset of oxidation and the period of time required for oxidation.

30

[0020] As in the formula noted above (Formula 1), the metal powder is preferably selected from the group consisting of aluminum powder (Al), sodium powder (Na), potassium powder (K), lithium powder (Li), magnesium powder (Mg), calcium powder (Ca), Manganese powder (Mn), Barium powder (Ba), Chromium powder (Cr), silicon powder (Si) and combinations thereof.

35

[0021] The proportions used to compose the mixture of metallic salts and powdered metal are defined according to the ratio of amounts of oxygen caused by the metallic salts and the amounts of oxygen required to oxidize the powdered metal. This ratio of generation versus requirement provides a ratio based on molecular weights calculated from chemical formulas.

40

[0022] The composition, function, and preparation process of a rapidly expanding metallic mixture is not part of the subject matter of this paper. There are various public domain documents or patents with this information.

[0023] The high temperature condition required to trigger the oxidation reaction of a rapidly expanding metal mixture can be achieved through various methods. However, one of the most widely used methods today consists of that described in patent EP 1 306 642 B1, in which a capsule structure is provided for a rapidly expanding metallic mixture, in which high-voltage arc discharge heat (causing temperatures of thousands of degrees), is used as the heat source.

45

[0024] As described in patent EP 1 306 642 B1, the capsule for a rapidly expanding metallic mixture comprises an outer casing made of an insulating material, with the rapidly expanding mixture contained in the outer casing, and two power supply rods extending outwardly from both ends of the outer casing. Two main firing electrodes are provided to induce arc discharge at the inner ends of the two power supply rods. The two main firing electrodes induce an arc discharge between them when high voltage is applied to them. When a high voltage of 2 kV or more is applied to the two feed rods, an arc discharge is induced between two trigger electrodes, instantly causing a high temperature of approximately 2,000°C or more at the positions around the positive and negative trigger electrodes. The voltage requirement varies according to the distance of the electrodes, namely, when the firing electrodes are spaced at intervals of 200 mm or more, a voltage of 6-7 kV or more needs to be applied to the trigger electrodes to induce an effective arc discharge between the electrodes. Nevertheless, in the case of activating trigger electrodes spaced at intervals of 100 mm or less, an equally effective arc discharge between the electrodes is induced, even with the use of a voltage of 3-4 kV. It is understood that the voltage level

55

has a slight variation depending on other conditions, such as type of resistance wires, as well as types and concentrations of electrolytes.

[0025] The disadvantages of this method lie mainly in the high voltage requirement necessary to achieve the high temperature that triggers the chemical reaction and the lack of a testing system to reduce or eliminate the existence of non-activated capsules.

[0026] The use of patent EP 1 306 642 B1 could be reduced in projects requiring a large volume of non-explosive fragmentation, because the high voltage required for the activation of the necessary chemical reaction would be a limiting factor for the number of capsules in the field. For example, if 10 boreholes are required in a given project, using the system of patent EP 1 306 642 B1, it would be necessary to connect 10 initiators in series; since the voltage requirement to activate the chemical reaction is 2 kV per capsule, the generator equipment must supply the system with 20 kV.

[0027] This development is related to a non-explosive programmable electronic initiator, whose purpose is to activate the chemical reaction of a rapidly expanding metallic mixture with a temperature higher than 1.000°C; whose main characteristics are: a low voltage requirement (less than 35 V), which allows a large number of capsules in the mesh to be fragmented (more than 400 capsules); a delay system (from 1 to 64,000 milliseconds), which allows greater precision and control of the fragmentation; a testing system that allows validation of the circuit prior to ignition, which eliminates the existence of non-activated capsules.

[0028] These differentiating characteristics individually and jointly improve the industrial applicability of a rapidly expanding metallic mixture in non-explosive rock fragmentation, significantly increasing production (fragmented m³), safety and control with a minimum energy requirement.

[0029] By way of summary, the technical problems that the present development aims to solve are based on delay, voltage, temperature, and multi-testing.

[0030] In general, fast-expanding metallic mixtures, unlike other similar products, do not have any explosive components. However, its use allows obtaining similar results and with important advantages such as a significant reduction of handling and transportation risks, due to the great stability of the chemical mixture against shocks, friction, pressure and high temperatures; significant reduction of risks of work accidents; operational continuity due to the fact that the evacuation of people and equipment is minimal in a radius close to the blasting area; lower environmental impact due to the minimum levels of vibration, noise, shrapnel and no toxic gases.

[0031] However, their use has been limited by some features of the current patents available on the market, which are outlined below:

a. Delay

[0032] A technical problem with rock blasting is its effect on the rock in the vicinity, as it can produce intense fragmentation and disruption of the integrity of the rock in the surrounding area if the blasting or drilling systems are incorrect. One of the measures used to minimize the environmental impact caused by high vibrations and improve the safety of field work is the time delay in blasting.

[0033] In this development, each initiator has a programmable delay system, which allows to program in advance and individually the required delay period according to the blasting schedule. Each Non-Explosive Programmable Electronic Initiator [07] can be programmed with a delay time in the range of 1 millisecond to 64,000 milliseconds.

[0034] In the case of patent EP 1 306 642 B1, another initiator of rapidly expanding metallic mixtures, the lack of delay time is observed.

[0035] Some electronic initiators for explosives have a programmable delay time, which is the case of patent US 6 173 651 (14,000 milliseconds, patent EP 1105693 B1, WO 0009967 A1 (according to patent 3,000 milliseconds, however, according to data sheet 30,000 milliseconds) whose initiators have the longest delay time known to date.

[0036] Another characteristic of a longer delay time would be the increase in productivity, since a greater number of drillings could be carried out for a more extensive blasting, maintaining a safe level with respect to vibrations and without having to re-equip the work area and reducing the workers' exposure to risk.

b. Voltage

[0037] In accordance with the provisions of the Regulation on High-Current Electrical Systems in Chile, high-voltage, high-current electrical systems or systems with rated voltages above 1,000V with a maximum of 220,000V are considered high voltage electrical systems and require a series of safety measures, while low voltage systems include systems or installations with rated voltages of between 100V and 1,000V. Understand the direct effect of this point on occupational safety and the potential effect of any accident related to the life and health of the workers involved.

[0038] A key feature of the present development is to deliver the voltage necessary to activate a single (or more than one) Programmable Non-Explosive Electronic Initiator [07] for a rapidly expanding metallic mixture. A voltage between 24V and 35V is required to activate the Programmable Non-Explosive Electronic Initiator [07]. The same voltage is

required to activate one hundred (100) or more units of Non-Explosive Programmable Electronic Initiator(s) [07]: 24V and 35V. The voltage requirement does not vary either by distance between activation electrodes or by electronic initiator units arranged in the line. This is because the connection of each Programmable Non-Explosive Electronic Initiator [07] to the line is in parallel.

5 **[0039]** In patent EP 1 306 642 B1, which considers an initiator for the activation of a rapidly expanding metallic mixture, each initiator requires 2,000V or more. Similarly, this patent points out different voltage requirements according to the distance between the activation electrodes: when the activation electrodes are separated by 200 mm or more, the voltage requirement for activation is between 6,000V and 7,000V; when the activation electrodes are separated by 100 mm or more, the voltage requirement for activation is between 3,000V and 4,000V. Because the connection of the initiators to the line is in series, the applied voltage is divided by the number of initiators on the line, so the voltage requirement of each initiator arranged in a blast increases the total voltage requirement.

10 **[0040]** In a concrete example, if 100 initiators were required to be used on a site, it is estimated that 200,000V (or more) would be required for initiators of the type proposed in patent EP 1 306 642 B1 to activate all the initiators. This requirement is impractical both in the mining industry and in civil works. If the same site were to use the Programmable Non-Explosive Electronic Initiators [07] proposed in this development, the total voltage requirement would be between 24V to 35V.

15 **[0041]** In other cases, the use of pyrotechnic drops or explosive tallow has been a solution to avoid the high voltage requirement, even if this means losing several of the qualities of the rapidly expanding metallic mixture, such as: reduced handling and transportation risks, reduced risk of occupational accidents, and operational continuity.

20 **[0042]** Other initiators such as, US 5 171 935 A, CA 2 339 167 C, US 8 746 144 B2, use a low voltage, however, they do not seek to reach a high temperature, a basic requirement for activation of the rapidly expanding metallic mixture.

c. Temperature

25 **[0043]** The voltage factor is also related to the high temperature condition required to trigger the oxidation reaction of a rapidly expanding metal mixture, as this can be achieved by various methods. In patent EP 1 306 642 B1, the high temperatures required (700 °C or more) for activation of the rapidly expanding metallic mixture is achieved by the high temperatures (thousands of degrees) caused by the electric arc from the high voltaic discharge; it is so large that it spares the existing filament in some instances.

30 **[0044]** In this development, the required high temperature (1,000 °C or more) is reached through the controlled discharge of Capacitor C7 [21] on the filament [30], leading it to glow for as long as needed, reaching the required temperature to activate the first rapidly expanding metallic mixture [13], which serves as a non-explosive tallow. Once the rapidly expanding metallic mixture [13] is activated, the necessary temperature (1,200 °C or more) is reached to activate the second rapidly expanding metallic mixture [15].

35 **[0045]** The higher temperature requirement (1,000 °C) for activating a rapidly expanding metallic mixture [13] in Programmable Non-Explosive Electronic Initiators [07] has a direct positive impact in terms of safety, both in terms of handling and transport.

d. Multi-Test System

40 **[0046]** It should also be noted that one of the key precautions to be taken in blasting, once the shot has been fired, is to examine the intervened area for the presence of non-activated initiators (misfire). An uncontrolled explosion could seriously endanger the integrity of the workers, so a team prepared for this purpose must guard the site and eliminate these shots, following the instructions established in the specific site's work procedures. Such is the seriousness of non-activated initiators (misfire), which are regulated by law in some countries.

45 **[0047]** The process requires, among other things, the presence of a supervisor during the entire operation, ensuring that the compromised area is cleared, removing unrelated workers and equipment, and using the minimum personnel necessary for this activity, thus reducing the number of people exposed to highly critical conditions.

50 **[0048]** This development involves a test system that avoids non-activated initiators (misfire) from taking place once the blasting is finished, reducing the labor risk in the field, allowing a safe execution and improving compliance with the blasting program.

[0049] By means of multiple internal diagnostics, the Programmable Non-Explosive Electronic Initiators [07] of the present development warn of specific errors:

- 55 • Communication failure between the Command Equipment [01] and the Programmable Electronic Non-Explosive Initiator(s) [07].
- Failure in the initial charge of Capacitor C7 [21].
- Failure in the final charge of Capacitor C7 [21].
- Filament continuity failure [30].

- Failure in the delay time value programmed in the EEPROM memory of Microprocessor IC1 [07].
- Failure in the system frequency change.

5 [0050] With the respective software diagnostics, the necessary information is obtained, ensuring the correct operation of the Programmable Non-Explosive Electronic Initiator(s) [07].

[0051] In the case of patent EP 1 306 642 B1, another initiator of rapidly expanding metallic mixtures, the lack of a test system may be observed.

[0052] Other patents such as WO 0009967 may include a test system focused on their needs; however, such systems lack a verification of the system's frequency shift.

10 [0053] The frequency change verification becomes essential to ensure the correct state prior to the activation of the "sleep" functionality of Microprocessor IC1 [07], which is directly related to the low voltage requirement and the achievement of the maximum delay time of 64,000 milliseconds.

[0054] Given all of the above, this development proposes advances that would allow the safe and productive, wide-spread use of the rapidly expanding metallic mixture.

15 Development background

Requirements for operating the development

20 [0055] It must be stated that this development is not limited to the particular methodology, compounds, materials, manufacturing techniques, uses, and applications described herein, as these may vary. It should also be understood that the terminology employed herein is used for the sole purpose of describing a particular embodiment, and is not intended to limit the perspective and potential of this invention.

25 [0056] It should be noted that in the use and method, here, in the statement of claims and throughout the text, the singular does not exclude the plural, unless the context clearly implies so. So, for example, the reference to a "use or method" is a reference to one or more uses or methods and includes equivalents known to those familiar with the subject matter (the art). Similarly, as a further example, the reference to "a step", "a stage" or "a mode" is a reference to one or more steps, stages, or modes and may include implied and/or upcoming sub-steps, stages, or modes.

30 [0057] All conjunctions used should be understood in the least restrictive and most inclusive sense possible. Thus, for example, the conjunction "or" should be understood in its orthodox logical sense, and not as an "or excluding", unless the context or the text expressly requires or indicates it. The structures, materials, and/or elements described must be understood to also refer to those functionally equivalent in order to avoid endless, exhaustive enumerations.

[0058] Expressions used to indicate approximations or conceptualizations should be understood as such, unless the context dictates a different interpretation.

35 [0059] All technical and/or scientific names and terms used herein have the common meaning given to them by an ordinary person qualified in these matters, unless expressly indicated otherwise.

[0060] Methods, techniques, elements, compounds, and compositions are described, although similar and/or equivalent methods, techniques, compounds, and compositions to those described may be used or preferred in practice and/or when testing this invention.

40 [0061] In order to provide clarity to the present development, the following concepts will be defined:

Delay: The concept of delay or delay time in the present development refers to the assignment of a countdown delay period measured in milliseconds (ms) that determines the firing sequence in a blast. Each detonator is assigned a previously defined time period (between 1 and 64,000 milliseconds).

45 Misfires: The concept of misfires for the present development refers to the complete or partial misfire of one (or more) capsule comprised in the firing sequence in a blast. It is a high-risk unintended consequence, in which product debris that can be activated by any mechanical effect during the excavation, milling or crushing stages of the mining process.

50 Microprocessor: The concept of microprocessor used for the present development refers to the set of integrated electronic circuits that carry out the instructions and tasks involved in information processing. The present development requires a Microprocessor with the following features: serial communication, low power consumption (preferably but not restricted to 20 nA in sleep mode), precision internal oscillator (preferably but not restricted to 31 KHz to 32 MHz), feasibility of integrating an external low frequency oscillator (preferably but not restricted to 32 KHz), memory capacity (preferably but not restricted to EEPROM 256 bytes, SRAM 256 bytes) and sufficient input and output ports to perform the functions required (at least 8). Microchip model PIC16LF1824/1828 has been identified as
55 a feasible Microprocessor for executing the commands and programs required in this development.

Communication protocol: a system of rules that allow two or more entities of a communication system to communicate with each other and transmit information. This development refers to the form of bidirectional communication between the Command Equipment [01] and the Non-Explosive Electronic Initiator(s) [07] that maintains the transmission of information and the voltage necessary for the operation of the Non-Explosive Electronic Initiator(s) [07], and which may take place under the bit per second transmission language through voltage pulses.

Filament: In the present development, the filament has a thickness, length and materiality that achieves a balance between capacitance and resistance to avoid it from being cut and achieving the necessary temperature. By way of example and without restricting the scope of this term, this could refer to a tungsten filament of a purity varying between 99.90% and 99, 99%, preferably 99.93%, 99.95% and 99.97%, in spiral form with a length varying between 1 and 3 mm, preferably 2 mm, 2.2 mm , 2.5 mm , with a diameter of a range between 0, 01 mm and 0.1 mm, preferably 0.01 mm, 0.02 mm, 0.03 mm and with a resistance ranging from 2.5 to 4.5 ohm, preferably 3 ohm, 3.2 ohm, 3.5 ohm, 3.6 ohm, 3.7 ohm, 3.8 ohm and 3.9 ohm.

Safety: The development addresses the precautions to be taken with the different devices, based on their manipulation and how to maintain the inactivation of the initiator through special commands created for such purpose.

Exothermic reaction: This development refers to any chemical reaction that gives off energy, either as light or heat, or, in other words, with a negative enthalpy variation.

Plasma: In the present development, plasma is considered as a rapidly expanding mixture of metallic salts that upon initiation produces a high-temperature exothermic reaction in a confined space. It is a very stable substance, as it does not react to high temperatures, shocks, friction, and high pressures. The reaction is initiated at high temperatures, above 1,000°C.

[0062] In order to operate the present development, a Command Equipment (Console or Master) [01], with the capacity to convert the serial communication into a communication protocol based on Voltage Modulation [03] through a Communication and Power Line (parallel lines) [02A and 02B], a connector [04] that connects said parallel lines with the Non Explosive Programmable Electronic Initiator(s) [07] (Figure 1A and 1B) and a RFID Card Reader (Logger) [06] are required.

[0063] Other general requirements for the operation of the Command Equipment [01] consist of, but are not limited to: external power supply (preferably 24V to 36V battery), microprocessor, Micro SD card, Bluetooth system, RFID reader [06], wireless transmission and display with keypad.

[0064] The operation of the development also requires a Communication and Power Line [02A and 02B] consisting of two parallel copper wires, each with a diameter greater than 0.5 millimeters, and a resistance of less than 36 ohm per kilometer. These cables play an essential role, and when used according to the instructions in Table I, they ensure both the reliability in the transmission of Voltage Modulation [03] and communication protocol (Figure 2), as well as the power received by each Programmable Non-Explosive Electronic Initiator [07].

Table I: Electrical Conductor Resistance

Maximum Copper Wire Resistance ohm/km at 20°C		
Diameter	Mono or Multipair	
	Cu (uncoated) ohm	Cu (coated) ohm
0,5	36,00	36,70
0,75	24,50	24,80
1	18,10	18,20
1,5	12,10	12,20
2,5	7,41	7,56
4	4,61	4,70
6	3,08	3,11
10	1,83	1,84

[0065] For this development to have a practical use (in the field), it should consider the use of a portion of two rapidly

expanding metallic mixtures [13] and [15] (PLASMA) with a formulation similar to the ones mentioned earlier, such as:

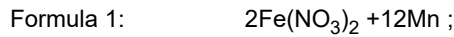

5 Patent No. 10-0213577

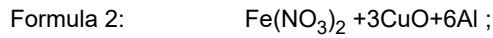

Patent No. 10-0213577

10

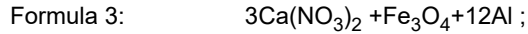

Patent No. 10-0213577

15

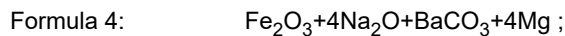

Patent No. 10-0213577

20



Patent No. 10-0213577

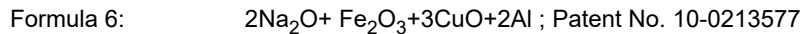

25

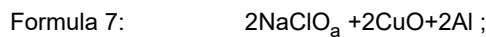

Patent No. 10-0213577

[0066] It should be understood that, for the use of the present development, the rapidly expanding metal mixtures [13] and [15] will be activated and the expected exothermic reaction will be triggered.

30

Development overview

[0067] The invention is defined by independent claims 1 and 12. Preferred embodiments are defined in the dependent claims.

35

[0068] The present development consists of a Programmable Non-Explosive Electronic Initiator [07], comprising a capsule with two types of rapidly expanding metallic mixture [13] and [15] that allows coupling to a container tube or sleeve [16] and a sealing plug [17] (Figure 3); and that, once it receives the Voltage Modulation [03] and the communication protocol (Figure 2), by means of commands, the functions that allow reaching the high temperatures required to initiate the chemical reaction are activated, using a low voltage requirement (less than 35V), with a delay system (from 1 ms to 64. 000 ms), and with a testing system that allows validation of the circuit prior to ignition.

40

[0069] An algorithm is programmed and saved in Microprocessor IC1 [28] in order to give functionality to the system. By means of functions and commands, this algorithm recognizes from the input signal, reads input data concerning the oscillator frequency (Figure 4) [28A], reads data from the filament and capacitor sensors (Figure 4) [28C], activates the ports (Figure 4) [28B] of capacitor charging, triggering, capacitor discharging, activation of the serial communication port (Figure 4) [28E], for sending data through the Communication and Power Line [02A and 02B] to the Command Unit [01], receiving the data through Interrupt (Figure 4) [28D], and the CPU central processing unit (Figure 4) [28F], which performs the task of processing all the functions as well as storing the information.

45

[0070] Each Non-Explosive Programmable Electronic Initiator [07] has a unique and unrepeatable identification (ID), which is recorded at the factory and matches the internal code of the external RFID card [05]. By means of an algorithm, the Command Equipment [01] captures this ID through the serial port via Bluetooth through the RFID reader equipment (Logger) [06] (Figure 1) and stores it in the MicroSD card belonging to the Command Equipment [01]. The data are available for further use in certain processes.

50

[0071] The Programmable Non-Explosive Electronic Initiator [07], has a Microprocessor IC1 [28] (Figure 4), with an Internal Oscillator and a non-volatile EEPROM memory [35] (Figure 5).

55

[0072] With the Command Equipment [01] activated, and all requirements for operation in order, the Communication and Power Line [02A and 02B] is activated, initiating the Voltage Modulation [03] and the communication protocol (Figure 2) coming from the Command Equipment [01]. At the beginning of the bidirectional communication, the Voltage Modulation [03] (Figure 2) sent consists of a constant square wave with a defined amplitude between 24V and 35V (Figure 2A) and a

period of 4.0 ms. The high bit of 4 milliseconds and the low bit of 0.2 milliseconds allow a constant voltage to be maintained (Figure 2A).

[0073] It is to be understood that the abovementioned Voltage Modulation [03] (Figure 2) is the one that allows to match the sending of data and energy necessary for the subsequent activation of one (or more) Programmable Non-Explosive Electronic Initiator [07].

[0074] A bidirectional communication protocol (Figure 2B and 2C) with a transmission rate of 2,400 bits per second is used in the Communication and Power Line [02A and 02B].

[0075] Data is sent at a communication rate equivalent to 2400 baud from the Command Equipment [01] via the Communication and Power Line [02A and 02B] and is received by the Programmable Non-Explosive Electronic Initiator(s) [07] (Figure 2C). Data is sent over the Communication and Power Line [02A and 02B] from the Programmable Non-Explosive Electronic Initiator(s) [07] and received by the Command Equipment [01] (Figure 2B). The sending of data from the Programmable Non-Explosive Electronic Initiator [07] to the Command Equipment [01] is determined by a 25 us (microsecond) bit, equivalent to 40,000 baud; data transmission (one byte) is performed on the low bit of the communication line.

[0076] The Programmable Non-Explosive Electronic Initiator input [07], comprises a diode D1 and a Voltage Rectifier D2 [18] (Figure 4), which are connected to the Communication and Power Line [02A and 02B]. Diode D1 suppresses transient currents and prevents current leakage. The D2 Voltage Rectifier, with voltage inputs between 24V and 35V, transforms alternating current (AC) into direct current (DC) (Figure 4).

[0077] A Voltage Regulator IC2 [20] receives the voltage from 24V to 35V and the rectified current (DC). This IC2 Voltage Regulator regulates the initial voltage to 5V (Figure 4).

[0078] For bidirectional communication between the Command Equipment [01] and the Programmable Non-Explosive Electronic Initiator [07], two voltage divider resistors R1 and R2 [24] are connected to the system input of the Programmable Non-Explosive Electronic Initiator [07], which lower the voltage from 24V-35V to 5V, thus adjusting to the operating level of the Microprocessor IC1 [28]. In addition, R1 operates with resistance between 90 and 170 Kohm, preferably 110 Kohm, preferably 120 Kohm and preferably 130 Kohm and R2 operates with resistance between 15 Kohm and 25 Kohm, preferably 110 Kohm, preferably 120 Kohm and preferably 130 Kohm. The square wave with the data is then transmitted from the Command Unit [01] to the INT/IO PORT input pin [41] (Figure 7) of the IC1 Microprocessor [28] and converted into bytes using an algorithm.

[0079] In response, the Microprocessor IC1 [28] through the EUSART transmission block [28E] (Figure 4) pin TX [43] (Figure 9), transmits the output data. The output data are inserted through a transistor T1 and two resistors R3 and R4 [23] in the Communication and Power Line [02A and 02B]. The response data is then sent to the Command Team [01] for processing (Figure 2B).

[0080] Two diodes D4 and D5 are connected to the 5V voltage input [19]. In this stage of the circuit, the input voltage 5V is reduced to 3.6V, which is necessary to operate the IC1 microprocessor [28]. Diodes D4 and D5 [19] suppress transient currents and prevent current leakage.

[0081] A 6.3V, 470 uF Capacitor C4 [19], connected to diodes D4 and D5 [19] and to the voltage input of Microprocessor IC1 [28], keeps the 3.6V input voltage stable. Capacitor C4 [19] is an energy reservoir that is continuously charged. It is essential to note that this device will be the power source for Microprocessor IC1 [28] and will keep it active for up to 64,000 milliseconds, once the Communication and Power Line [02A and 02B] is interrupted. The discharge time of this capacitor must be greater than the programmed delay time; this point is addressed in more depth when describing the operation of the External Oscillator [25] (Figure 4) and OSC [36] (Figure 6).

[0082] Two resistors R6 and R7 [26] divide the voltage between Ground (GND), Filament [30] and Capacitor C7 [08] (Figure 3 and 4) of 35V. Filament [30] is a Tungsten spiral with a length ranging from 1 to 3 mm, preferably 2 mm, 2.2 mm, 2.5 mm, with a diameter ranging from 0.01 mm to 0.1 mm, preferably 0.01 mm, 0.02 mm, 0.03 mm and with a resistance ranging between 2.5 and 4.5 ohm, preferably 3 ohm, 3.2 ohm, 3.5 ohm, 3.6 ohm, 3.7 ohm, 3.8 ohm and 3.9 ohm.

[0083] As a safety measure, a transistor T4 [22] (Figure 4) connected to a series resistor R12 (current limiter), which in turn is connected to ground (Vss or GND), maintains the Filament [30] and the Capacitor C7 [21] with a voltage lower than 1V. The Transistor T4 [22] is deactivated by issuing a command (Command 5) to start the charging process of Capacitor C7 [21], prior to firing. Once all the elements of the circuit have been activated, if any fault is detected, through a command (Command 6), this Transistor T4 [22] discharges to ground (Vss or GND) the Capacitor C7 [21], reducing the voltage of the Capacitor C7 [21] to a value lower than 1 V and preventing the Filament [30] from having the necessary voltage to ignite and activate the metallic fast-expansion mixture.

[0084] Filament [30] is connected to Capacitor C7 [21] (initial charge 0V) and transistor T2 [27]. Once the Trigger Command (Command 7) has been activated, the I/O PORT pin C5 [28B] (Figure 4) activates the transistor T2 [27] to discharge the Capacitor C7 [21] in the Filament [30], causing it to glow.

[0085] Resistor R9 [21] limits the input current to a value ranging between 2 and 3 milliamps, this allows a slow charging of Capacitor C7 [21] and a minimum current consumption. Diode D3 [21] prevents current leakage from Capacitor C7 [21].

[0086] The resulting analog voltage between resistors R6 and R7 [26] (DC) enters the ADC/AN pin [28C] (Figure 4). The

analog information received by the Microprocessor IC1 [28] through the ADC/AN pin [42] (Figure 8) is converted to digital for sensor readout.

[0087] The arrangement of the elements, together with the processes and commands activated by means of an algorithm, allow for establishing a Test System based on the values provided by the sensor configured on the ADC/AN pin [42] (Figure 8) belonging to Microprocessor IC1 [28] (Figure 4).

[0088] The Test System is powered by the sensor data configured on the ADC/AN pin [42] (Figure 8). The data obtained are analyzed by means of an internal algorithm of Microprocessor IC1 [28].

[0089] The Performance Test System is activated via Command 3 (described below) and consists of the following tests:

• Communication Check:

◦ Using an algorithm, a data frame is sent to each (unique) ID and a response is expected. The maximum waiting time is 150 milliseconds.

A response time > 150 milliseconds implies a communication error.

• Filament Check

◦ By means of an algorithm, a voltage calculation yields a given result in absolute units. A reading with an absolute value of 0 (zero) in the sensor means that the Filament [30] has been severed.

Absolute Value = 0 means Unusable Initiator

• Capacitor C7 Initial Status Check [21]:

◦ At system startup, a transistor T4 [22] (Figure 4) connected to a resistor R12 [22] is activated to connect the positive output of capacitor C7 [21] to ground (Vss or GND) and maintains the capacitor load at a voltage below 1V. The check of the initial state of capacitor C7 [21] consists of measuring the voltage of capacitor C7 through sensor [28C]. The sensor reads the voltage data from Capacitor C7 [21] and stores it in a 10-bit variable in Microprocessor IC1 [28] equivalent to a given number of 1024 parts. Considering that the initial voltage is in a range between 24V and 35V, one part equals a range between 0.023V and 0.034V; then a range between 30 and 43 parts equals a voltage of less than 1V. The reading after this milestone should be less than 1V. A reading greater than this value means that either Capacitor C7 [21] is defective or Transistor T4 [22] is defective.

Voltage Capacitor C7 [21] ≥ 1V implies that the Initiator is Unusable.

• Capacitor C7 Initial Charge Status Check [31]:

◦ Transistor T4 [22] connected to resistor R12 [22] is deactivated and left ungrounded. Transistor T3 [29] is activated and through resistors R5 and R10 [29], which begins charging Capacitor C7 [21]. The sensor reads and stores data regarding the state of charge of Capacitor C7 [21] every 30 milliseconds during the 30 seconds of the programmed charge. The data is stored in a 10-bit variable in the IC1 microprocessor [21] equivalent to a given number of 1024 parts. At the end of the charging period (30 s), the reading of Capacitor C7 [21] should be greater or equal to 800 parts, a fraction that indicates sufficient voltage to generate the required glow in the filament [30].

Voltage Capacitor C7 [21] < 800 parts implies that the Initiator is Unusable.

• Programmed Delay Verification:

◦ By means of an algorithm and through a command (Command 3), data regarding the programmed delay is sent from the Command Unit [01] to the Programmable Non-Explosive Electronic Initiator [07] and stored in the non-volatile EEPROM memory of Microprocessor IC1 [28]. The Programmable Non-Explosive Electronic Initiator [07] uses an algorithm to verify that the data sent by the Command Unit [01] is equal to the data received by the Microprocessor IC1 [28]. Microprocessor IC1 [28] sends a response to the Command Unit [01].

The programmed waiting time is 150 milliseconds.

A response time > 150 milliseconds implies a communication error.

If the response data concerning the delay is identical to the data sent by the Command Team [01], an acknowledgement code (ACK) is received.

If the response data concerning the delay is different to the data sent by the Command Team [01], an error code is received.

- External Oscillator Status Check [25] and Frequency Change for sleep mode:

o At system startup, the External Oscillator [25] is activated and the pulses per second emitted are read. These pulses must coincide with the frequency of 32 KHz. Once the related data has been recorded in the non-volatile EEPROM memory of Microprocessor IC1 [28], the External Oscillator [25] is deactivated.

Recorded pulses of the External Oscillator [25] = 32,000 per second If the response data concerning pulses is different to 32,000 the Command Team [01], an error code is received.

[0090] Microprocessor IC1 [28], which has an internal oscillator of preferably 16 MHz [28A] (Figure 4) -although higher frequency alternatives are not excluded-, has a power consumption of approximately 2 mA (milliamperes). Figure 6 is a detailed representation of the dynamics generated in Clock Source Block [28A] pertaining to Figure 4.

[0091] This development includes a 32 kHz External Oscillator Q1 [25] (Figure 4) connected to Microprocessor IC1 [28], whose objective is to reduce power consumption by lowering the system frequency from 16 MHz to 32 KHz.

[0092] The Filament [30] (Figure 4) is made by spiral shaped Tungsten wire with a length ranging from 1 to 3 mm, preferably 2 mm, 2.2 mm, 2.5 mm, with a diameter ranging from 0, 01 mm and 0.1 mm, preferably 0.01, 0.02, 0.03 and with a resistance ranging from 2.5 to 4.5 ohm, preferably 3 ohm, 3.2 ohm, 3.5 ohm, 3.6 ohm, 3.7 ohm, 3.8 ohm and 3.9 ohm.

[0093] In Figure 3, which describes the Printed Circuit Board (PCB) [10], the Filament [12] (the same one shown as Filament [30] in Figure 4, schematic circuit) is supported on a solid base [11], covered with a Rapidly Expanding Metal Mixture [13], both inserted in a Shrink Sleeve [14]. It is the Shrink Sleeve [14] that keeps the Filament [12] bound to the Rapidly Expanding Metal Mixture [13]. The Shrink Sleeve [14] is encased by a Capsule container [16] which in turn contains another quantity of a Rapidly Expanding Metal Mixture [15], sealed with a plug [17].

[0094] An External Oscillator Q1 [25] of lower frequency than the internal oscillator of the Microprocessor IC1 [28], emits pulses that are read by TIMER1 [37] (Figure 6). The count of these pulses, performed by TIMER1, is stored and made available for reading by means of an algorithm.

[0095] Using an algorithm, the operation of the External Oscillator Q1 [25] is automatically enabled once the internal oscillator of the Microprocessor IC1 [28] becomes disabled.

[0096] When the internal oscillator of Microprocessor IC1 [28] is turned off and the External Oscillator Q1 [25] starts to operate, the TIMER1 [37] (Figure 6) of Microprocessor IC1 [28] can read the pulses emitted by it and use an algorithm to associate their equivalence in time.

[0097] The delay time is defined in the field and before issuing the Fire command. The defined delay time is programmed in the Programmable Non-Explosive Electronic Initiator(s) [07] through the Command Set [01]. The data related to the programmed delay time is stored in the non-volatile EEPROM memory of the Microprocessor IC1 [28] of each Programmable Non-Explosive Electronic Initiator [07].

[0098] The delay time of each Programmable Non-Explosive Electronic Initiator [07] is limited by three characteristics associated with different functionalities.

[0099] Capacitor C4 [19] (Figure 4) plays the role of external battery of Microprocessor IC1 [28] after the line break; the charge autonomy of Capacitor C4 [19] is decisive for the maximum operating time of Microprocessor IC1 [28] once the "Fire" command (Command 7) is activated and the Communication and Power Line [02A and 02B] is cut.

[0100] The 32 kHz External Oscillator Q1 [25] [25] emits 32,000 pulses per second, these are counted by TIMER1 [37] (Figure 6) of Microprocessor IC1 [28]. These pulses use an algorithm to time them and count down to the programmed delay time.

[0101] Microprocessor IC1 [28] has a sleep mode function, which is activated by an instruction. When entering sleep mode, the TIMER1 oscillator of Microprocessor IC1 [37] is not affected and the peripherals operating from it can continue to operate in sleep mode (Figure 6); the existence of an External Oscillator Q1 [25], allows to use the "sleep" function of the IC1 Microprocessor [28] and substantially reduces its power consumption; note that, even though the sleep function could be activated with the internal oscillator of the IC1 Microprocessor [28], its power consumption is 600 nA. Using the External Oscillator Q1 [25] and having activated the "sleep" functionality, this consumption is 20nA.

[0102] Due to the low power consumption obtained with the activation of the External Oscillator Q1 [25], we may achieve a sleep state of more than 64,000 milliseconds due to the activation of the "sleep" function of the Microprocessor IC1 [28] and the autonomy of the Capacitor C4 [19].

[0103] All in all, the programmable delay time of each Programmable Non-Explosive Electronic Initiator [07] is limited to a range between 1 and 64,000 milliseconds.

[0104] When the programmed delay time (Command 2) is reached, Microprocessor IC1 [28] is interrupted internally, deactivating the "sleep" mode and activating the other functions required to complete the final firing.

[0105] The activation of Fire (Command 6), causes the following actions:

EP 4 239 278 B1

- a) All the interrupts of Microprocessor IC1 [28] are disconnected to avoid an early awakening of the sleep function.
- b) The load of Capacitor C7 [21] is disconnected, so that it maintains its charge at maximum while Microprocessor IC1 [28] is in "sleep" mode and TIMER1 counts down.
- 5 c) Information related to the delay time stored in the non-volatile EEPROM memory of Microprocessor IC1 [28] is retrieved and the programmed delay time is loaded into the TIMER1 counter (Command 2).
- 10 d) The "sleep" function of Microprocessor IC1 [28] is enabled and only TIMER1 is kept running to start the delay time countdown.
- e) The delay time countdown starts.

[0106] Once the delay time has elapsed, Capacitor C7 [21] is enabled; at that moment Transistor T2 (NPN) [27] and its Resistor R8 [27] are enabled to discharge all the energy accumulated in Capacitor C7 [21] on the Filament [30] (Figure 4).

[0107] The Filament [30] then begins to glow, generating a temperature of more than 1,200 °C due to the capacitance of Capacitor C7 [21] of between 24V and 35 V and a current of approximately 0.250 A, which activates the Rapidly Expanding Metal Mixture [13] (Figure 3). This exothermic reaction reaches a temperature greater than 1,200 °C, which activates the Rapidly Expanding Metal Mixture [15].

Processes

[0108] The Programmable Non-Explosive Electronic Initiator [07] performs the processes described below:

25 Process 1: The input voltage (24V to 35V) of the Programmable Non-Explosive Electronic Initiator [07] is rectified by means of two capacitors, C1 and C2 [18], a diode D1 and a bridge rectifier D2 [18].

30 Process 2: Capacitor C3 [20] keeps the input voltage stable (24V and 35V). The voltage regulator IC2 [20], lowers the input voltage (24V and 35V) to 5V, the input voltage for diodes D4 and D5 [19].

Process 3: The data enters the Programmable Non-Explosive Electronic Initiator [07] through resistors R1 and R2 [24] (Figure 04). These resistors filter (separate) the byte frame associated with the incoming data and reduce its input voltage (between 24V and 35V) to the level required by the IC1 microprocessor [28] (between 3.3V and 5.0V).

35 Process 4: Two diodes D4 and D5 [19] are placed on the voltage input line to the IC1 microprocessor [28]. These components regulate the voltage to the one required by the IC1 microprocessor [28] (3.6V) and stop the current leakage. Also, a 470 uF Capacitor C4 [19] is placed on the input voltage line to the IC1 Microprocessor [28], which keeps the input voltage stable (3.6V). Capacitor C4 [19] also fulfills the role of an energy accumulator.

40 Process 5: Microprocessor IC1 [28] has a PIN configured as a sensor. The sensor is connected to two resistors R6 and R7 [26], which play the role of voltage divider, between Capacitor C7 [21], Filament [30] and ground (VSS).

[0109] The sensor [28C] (Figure 4) reads the data resulting from the Filament continuity check [30] (Command 3). The resistance value is expected to be between 2.5 and 4.5 ohm.

45 **[0110]** Using an algorithm, the IC1 microprocessor sensor [28] reads the initial charge state of Capacitor C7 [21]. The first sampling is expected to be less than 1V (Command 3).

[0111] Process 6: Microprocessor IC1 [28] deactivates Transistor T4 [22], activates the PIN connected to Transistor T3 [29] through Resistors R10 and R5 [29]. This allows the charging of Capacitor C7 [21] to be initiated. The charging process of Capacitor C7 [21] is programmed for 30 seconds.

50 **[0112]** Process 7: The IC1 Microprocessor sensor [28] records charge voltage data every 30 milliseconds during the 30 seconds of charging Capacitor C7 [28]. The generated data are stored in a non-volatile EEPROM memory of the IC1 microprocessor [28]. The data will be processed via Command 3, indicated further below.

[0113] Process 8: Capacitor C7 [21] is connected to the rectified power line (Process 1). Resistor R9 [21] and diode D3 [21] limit the system load. A slow charging of Capacitor C7 [21] (30 sec) and a current consumption between 2 and 3 milliamps is generated. Process 9: Connected to Microprocessor IC1 [28], External Oscillator Q1 [25] and Capacitors C5 and C6 [25] keep the 32 kHz oscillation stable.

55 **[0114]** Process 10: The output Transistor T1 [23] and Resistors R3 and R4 [23] send the response frame once the commands (indicated below) have been processed through the bidirectional communication protocol (Figure 2).

EP 4 239 278 B1

[0115] Process 11: Microprocessor IC1 [28] activates transistor T2 [27] through Resistor R8 [27]. Capacitor C7 [21] discharges through the Filament [30], causing the Filament [30] to glow.

[0116] Process 12: The glowing Filament [30] reaches a temperature above 1,000 °C and activates the Rapidly Expanding Metal Mixture [13] (Figure 3).

5 [0117] Process 13: The exothermic reaction of the activation of the Rapidly Expanding Metal Mixture [13] allows reaching a temperature of 1,200 C and activates the Rapidly Expanding Metal Mixture [15].

Commands

10 [0118] Command 1: Records the ID, the RFID identifier code [05], in the non-volatile EEPROM memory of the IC1 microprocessor [28], which uniquely identifies a Programmable Non-Explosive Electronic Initiator [07].

[0119] Command 2: It saves in the non-volatile EEPROM memory of Microprocessor IC1 [28] the programmed delay time, which varies between 1 millisecond and 64,000 milliseconds.

[0120] Command 3: Query ID. It diagnoses the current functionality, except for Command 7 (Fire).

15 • Diagnosis 1: An algorithm is used to test the response time of the Programmable Non-Explosive Electronic Initiator [07]. If the response time exceeds a programmed time limit (100 milliseconds), it responds with an error code.

20 • Diagnosis 2: A sensor is used to check that the charge in Capacitor C7 [21] from 470 uF to 2,200 uF is less than 1V (Volt). In case of failure, it responds with an error code. In case of error, transistor T4 [22] is activated and forces capacitor C7 [21] to ground (Vss or GND).

25 • Diagnosis 3: A sensor is used to check that the filament [30] has continuity between 2.5 and 4.5 ohm. In case of failure, it responds with an error code. In case of error, transistor T4 [22] is activated and forces capacitor C7 [21] to ground (Vss or GND).

30 • Diagnosis 4: An algorithm is used to retrieve the data associated with the programmed delay stored in the non-volatile EEPROM memory of the IC1 microprocessor [28]. The data is checked to ensure that it matches the data of to the programmed delay time sent by the Command Equipment [01]. In case of failure, it responds with an error code.

• Diagnosis 5: An algorithm is used to retrieve the data associated with the frequency of the External Oscillator [25], stored in the non-volatile EEPROM memory of Microprocessor IC1 [28] at the start of the system. If the register shows an error, transistor T4 [22] is activated and forces capacitor C7 [21] to discharge to ground (Vss or GND).

35 [0121] Command 4: Allows change of location of one (or more) Programmable Non-Explosive Electronic Initiator [07]. Allows to modify the delay assignment of one (or more) Programmable Non-Explosive Electronic Initiator [07]. Allows manual reprogramming of one (or more) Programmable Non-Explosive Electronic Initiators [07].

40 [0122] Command 5: Preparation before firing. Disable Transistor T4 [22] to exit the grounded state. Enables Transistor T3 [29] to proceed with charging Capacitor C7 [21] over a 30 second time period; reads and stores the charge data of Capacitor C7 [21] every 30 milliseconds during the 30 second charge. Stored data is available for reading in a variable of Microprocessor IC1 [28]. Disables the internal oscillator (16 Mhz) of Microprocessor IC1 [28] and enables the External Oscillator [25] (32 KHz).

[0123] At this point, the user must repeat Command 3 to check again that the system is operational including the status change of Capacitor C7 [21].

45 [0124] Command 6: Safety measure in case of any failure. If Command 5 fails, it responds with an error code, Transistor T4 [22] is activated, connecting Capacitor C7 [21] to ground and discharging it.

50 [0125] Command 7: Fire. Disables external interrupts of the microprocessor [28]. Disables the charging of Capacitor C7 [21]. TIMER1 is loaded with the data related to the delay time. Activates the "sleep" function of Microprocessor IC1 [21]. Enables countdown of the assigned delay time of the Programmable Non-Explosive Electronic Initiator [07]. At the end of the countdown assigned to the programmed delay time, activates Capacitor C7 [21]. Activates I/O output PORT C5 [40] (Figure 7) of Microprocessor IC1 [28] and Transistor T2 [27].

Description of the figures

55 [0126] In order to better describe the figures, below is a list of all the items shown in them:

[01] Command Equipment (Console or Master)

[02A] Communication and Power Line

- [02B] Communication and Power Line (VSS or GND)
- [03] Voltage Modulation
- [04] Connector
- [05] External RFID card
- 5 [06] Logger, RFID Reader
- [07] Programmable Non-Explosive Electronic Initiator
- [08] Capacitor C7
- [09] PCB Printed Circuit Board
- [10] PCB Printed Circuit Board Card
- 10 [11] Solid filament base
- [12] Filament (Figure 4) [30]
- [13] First metallic mixture
- [14] Shrink Sleeve
- [15] Second metallic mixture
- 15 [16] Container capsule
- [17] Container capsule plug
- [18] D2, C1, C2, D1 Voltage Rectifier Block
- [19] IC1, D4, D5, C4 Microcontroller Voltage input block
- [20] IC2, C3, Voltage Regulator Block
- 20 [21] C7, D3, R9 Capacitor charging and discharging block
- [22] C7, R11, R12 Capacitor Discharge Block
- [23] T1, R3, R4 data to communication line transmitter block
- [24] Voltage divider block with data to block 28D (INT), R1, R2
- [25] Q1, C5, C6 External Oscillator Block
- 25 [26] 28C, R6, R7 voltage divider block to ADC block sensor
- [27] T2, R8 Firing Regulator Block
- [28] IC1 Microcontroller Block
- [28A] Clock Source
- [28B] I/O input and output ports
- 30 [28C] Sensor Input (ADC Analog to Digital)
- [28D] Interruption when entering data through the port
- [28E] TX transmission serial data output (UART)
- [28F] CPU Function and data storage processor
- [29] C7, T3, R10, R5 Capacitor load activation block
- 35 [30] Filament (Figure 3) [12]
- [31] IC1 Microcontroller Programming Socket
- [32] IC1 Microcontroller Programming Flash Memory
- [33] CPU with its internal peripherals attached
- [34] External Oscillator and time generator connection block to the CPU
- 40 [35] CPU-connected peripheral bus
- [36] Clock source of IC1 microcontroller, OSC (External Oscillator)
- [37] Pulse source for TIMER1 counter from OSC Q1.
- [38] Output I/O port for charging Capacitor C7 (28B Figure 4)
- [39] Output I/O Port for discharging Capacitor C7(28B Figure 4)
- 45 [40] Output I/O Port for firing, discharge of Capacitor C7 on Filament [30] (28B Figure 4)
- [41] Input I/O port via interrupt (INT), for data processing (28D Fig. 4)
- [42] Input to the ADC module, for the voltage sensor. (28C Figure 4)
- [43] Serial transmission output PIN TX (UART) (28E Figure 4)

50 Figure 1:
 This figure shows two diagrams, A and B, where the left diagram or Figure 1A shows the arrangement of the elements of the present system using a single parallel Communication and Power line [02A and 02B] for a single Programmable Non-Explosive Electronic Initiator [07] and an RFID reader that reads the unique identifier code ID of the Programmable Non-Explosive Electronic Initiator [07]. Diagram B, or Figure B, shows the present system using a single parallel Communication and Power line [02A and 02B] for four or more Programmable Non-Explosive Electronic Initiators [07].

55 Figure 2:
 This figure shows three diagrams A, B and C, representing voltage waves, where figure 2A, above, shows the

beginning of the bidirectional communication, where the Voltage Modulation [03] sent consists of a constant square wave with a defined amplitude between 24V and 35V and a period of 4.0 ms. The high bit of 4 milliseconds and the low bit of 0.2 milliseconds allow for a constant voltage to be maintained. Figures 2B and 2C present diagrams showing the details of a bidirectional communication protocol with a transmission rate of 2,400 bits per second that is used in the Communication and Power Line [02A and 02B].

Figure 3:

This figure shows three diagrams: A, B and C, where the first two show a schematic description of the Printed Circuit Board (PCB). Diagram C shows a detail of the interaction between Filament [12] coated with a Rapidly Expanding Metal Mixture [13], inserted in a Shrink Sleeve [14], where the Shrink Sleeve [14] holds together the Filament [12] with the Rapidly Expanding Metal Mixture [13], and where the Shrink Sleeve [14] is contained by a Capsule container [16] which in turn contains another amount of a Rapidly Expanding Metal Mixture [15].

Figure 4: This figure shows a schematic circuit of the Programmable Non-Explosive Electronic Initiator [07].

Figure 5:

This figure shows a specification of the CPU programming and feedback [28F] described in the schematic circuit of the Programmable Non-Explosive Electronic Initiator [07].

Figure 6:

This figure is a detailed representation of the dynamics generated in the Clock Source Block [28A].

Figure 7:

This figure shows a diagram of how the square wave with the data is transmitted from the Command Unit [01] to the INT/IO PORT input pin [41] and IO output ports [28B] (for charging Capacitor C7 [38], for discharging Capacitor C7 [39], for firing and discharging Capacitor C7 in Filament [30] [40]) (Figure 4) of the IC1 Microprocessor [28], converting it into bytes with the use of an algorithm. On the other hand, Figure 7 refers to PINs C0, C3, C5 of the IC1 microcontroller in Figure 4.

Figure 8:

This figure shows a diagram of the analog information received by the Microprocessor IC1 [28] through the ADC/AN pin [42] (Figure 4) [28C] where it is converted to digital for sensor readout.

Figure 9:

This figure shows a diagram of how Microprocessor IC1 [28], through the USART transmission block pin TX [43] (Figure 4) [28E], transmits the output data, where the output data is inserted through a transistor T1 and two resistors R3 and R4 [23] in the Communication and Power Line [02A and 02B].

Example of application

[0127] In order to calculate the ignition temperature of the primary metallic mixture, the following mixture Al + Fe2O3 + NaNO3 (Aluminum + Iron Oxide + Sodium Nitrate) was used, using the following equations: The resistivity of a metal (ρ) increases with temperature; this relationship is determined by the following equation:

$$\rho(T) = \rho_0 (1 + \alpha (\Delta T)) \quad \text{(Equation No. 1)}$$

Where:

- $\rho(T)$ = Resistivity of a metal as a function of a temperature differential.
- ρ_0 = Initial metal resistivity.
- α = Temperature coefficient per centigrade degree of the metal.
- ΔT = Temperature differential ($T_{Final} - T_{initial}$).

[0128] In turn, the resistivity of a metal is directly proportional to the resistance of the metal, the relationship between the two is given by:

$$R = \rho * L / A \quad \text{(Equation No.2)}$$

Where:

- R = Metal resistance
- ρ = Metal resistivity
- L = Length of metal wire
- A = Wire surface

[0129] Knowing the values at an ambient temperature of $T_o = 20^\circ\text{C}$ and R_o at that temperature equal to 10.5Ω , the temperature coefficient (α) of tungsten is $\alpha=0.0045$. If we do an experimental calculation of the RF resistance of tungsten, we get, when applying a voltage of $V=24 \text{ V}$ (volts), $20V$ calculated by the voltage drop and an electric current $I=0.100 \text{ A}$ (amperes) and substituting the resistivity (ρ) of equation No. 2 in equation No. 1.

$$\rho = R \cdot A / L \quad (\text{Equation No.2})$$

$$(R \cdot A (T)) / L = (R_o \cdot A (1 + \alpha (T_F - T_o))) / L \quad (\text{Equation No.1})$$

[0130] Multiplying both members by L / A

$$(R \cdot A (T) \cdot L) \cdot (L/A) = (R_o \cdot A (1 + \alpha (T_F - T_o))) \cdot (L/A)$$

$$R(T) = R_o (1 + \alpha (T_F - T_o)) \quad (\text{Equation No.3})$$

Where:

- $R(T)$ = Resistance of the metal to a temperature variation.
- R_o = Metal resistance at T_o
- α = Temperature coefficient per centigrade degree of the metal.
- T_F = Temperature variation with respect to the initial temperature
- T_o = Initial metal temperature

[0131] Determining variable T_F from equation No.3:

$$T_F = ((R_F / R_o) - 1) / \alpha + T_o \quad (\text{Equation No.4})$$

[0132] Calculating experimentally with the discharge of capacitor C7 gives us a final resistance per temperature difference of 90 ohm , substituting these values in equation No.4:

$$T_F = ((90\Omega / 10,5\Omega) - 1) / 0,0045 + 20^\circ\text{C}$$

$$T_F = 1.702^\circ\text{C}$$

[0133] Based on the results obtained, it is concluded that at an ambient temperature of 20°C , the filament temperature for igniting the first rapidly expanding metallic mixture [13] is approximately $1,702^\circ\text{C}$.

[0134] Considering that the melting point of tungsten metal is $3,422^\circ\text{C}$, it is concluded that the filament will not break before activating the first rapidly expanding metallic mixture [13].

[0135] Since the filament incandescence has a time limit [30], in an environment exposed to oxygen (no vacuum) its consumption is inevitable. Once the discharge of capacitor C7 [31a] is activated, the minimum average glow period of filament [30] is greater than 100 milliseconds , enough time for the glow of filament [30] to activate the first rapidly expanding metallic mixture [13].

Claims

1. - A Programmable Non-Explosive Electronic Initiator (07) for a rapidly expanding metal mixture and/or plasma, WHEREIN it comprises a capsule, containing attached a first rapidly expanding metal mixture (13) and a second

rapidly expanding metal mixture (15) with activation temperatures above 1000°C; where the capsule corresponds to a container tube or sleeve (16) which is closed with a sealing plug (17); which receives a communication protocol based on voltage modulation (03), by means of a communication and power line (02a, 02b) using a bidirectional serial algorithm from an external command equipment (01); a capacitor (C7, 8, 21), with a voltage requirement under 35V which by means of a controlled discharge on a filament (12, 30) produces the filament to glow, where this filament (12, 30) is supported on a solid base (11) covered with the first expanding metallic mixture (13) which is activated above 1000°C, wherein both are inserted in a shrink sleeve (14) which holds them together, wherein the shrink sleeve (14), which holds them together, where the shrink sleeve is contained inside the capsule container (16) which in turn contains the second rapidly expanding metallic mixture (15) which is activated above 1200°C; a PCB printed circuit board (10) with a PCB printed circuit (9) that controls the discharge, its delay between 1 ms to 64,000 ms and its testing so that the circuit may be checked prior to ignition.

2. - The electronic initiator according to claim 1, WHEREIN the PCB printed circuit board (9) comprises a microprocessor (IC1, 28), with a unique and unrepeatable identification code (ID), which receives the bidirectional communication coming from the external command equipment (01) and processes the different commands to activate the Programmable Non-Explosive Electronic Initiator (07), where the Microprocessor (IC1, 28) further comprises a non-volatile EEPROM memory, which stores the unique and unrepeatable identification code (ID), the delay parameters and an internal oscillator, where a PIN of the Microprocessor (IC1, 28) operates as input for signal processing functioning as initial and final charge sensor of Capacitor (C7, 8, 21) and sensing the continuity of Filament (30), a flash microcontroller, a programming unit (28F) of RAM memory (44) belonging to Microprocessor (IC1, 28); a Capacitor (C4, 19) that maintains the stability and autonomy of the input voltage to the Microprocessor once the trigger command is received; an External Oscillator Q1 (25) connected to the Microprocessor of lower oscillation frequency than the internal oscillator of the latter to deliver the pulses to a TIMER (28A) of the Microprocessor (IC1, 28).
3. - The Electronic Initiator, according to claim 2, WHEREIN an I/O PORT PIN (C0) in the Microprocessor (IC1, 28) which is connected to two resistors (R5, R10), activates the transistor (T3) producing the charge of the Capacitor (C7, 8, 21).
4. - The electronic initiator, according to claim 2, WHEREIN the Capacitor (C4, 19) has a high capacitance with ranges above 300 µF, preferably 470 µF of tantalum, maintaining the stability of the input voltage to the Microprocessor (IC1, 28) as well as the energy reservoir to allow the Microprocessor to remain autonomous through the programmed delay period once the trigger has been activated and the Communication and Power Line (02A, 02B) are interrupted.
5. - The electronic initiator, according to claim 2, WHEREIN the External Oscillator (Q1, 25) has a frequency of 32,000 Hertz, a lower frequency than the internal oscillator of Microprocessor (IC1, 28), connected to Microprocessor (IC1, 28), where a command deactivates the internal oscillator of Microprocessor (IC1, 28) and activates the low frequency External Oscillator (Q1, 25), where the activation of External Oscillator (Q1, 25) reduces the frequency and power consumption of Microprocessor (IC1, 28) by 250 to 500 times, where the External Oscillator (Q1, 25) in combination with the activation of the "sleep" function of the Microprocessor (IC1, 28), reduce power consumption from mA to nA, thus achieving the maximum programmable delay time of 64,000 milliseconds.
6. - The electronic initiator, according to claim 5, WHEREIN the External Oscillator (Q1, 25) is the agent emitting pulses for the TIMER1 to count said pulses and determine the time, this information is stored and is available for reading by means of Software, where 32 pulses emitted by External Oscillator (Q1, 25) and read by the TIMER1 are equivalent to 1 millisecond.
7. - The Electronic Initiator, according to Claims 2, 5 and 6, WHEREIN due to the low energy consumption achieved with the activation of the External Oscillator (Q1, 25), the activation of the "sleep" function of the Microprocessor (IC1, 28) and the autonomy of the Capacitor (C4, 19), achieve a sleep state of more than 64,000 milliseconds, where the delay time is programmable from each Programmable Non-Explosive Electronic Initiator (07) and limited to a range between 1 and 64,000 milliseconds.
8. - The Electronic Initiator, according to claim 1, WHEREIN the filament (30), comprises a spiral shape, whose incandescence is capable of reaching a high temperature that activates the first Rapidly Expanding Metal Mixture (13) adhered to it, through the complete discharge of the Capacitor (C7, 21).
9. - The Electronic Initiator, according to claim 1, WHEREIN the Programmable Non-Explosive Electronic Initiator (07), [07], the communication and power line (02a, 02b) and the command equipment (01) communicate through a square wave frame, keeping the Programmable Non-Explosive Electronic Initiator(s) (07) synchronized in time.

10. - The Electronic Initiator, according to claim 2, WHEREIN the capacitor (C7, 21) of 35V and with a Resistor (R9, 21) connected in series with said Capacitor (C7, 21), allows a slow charge of Capacitor (C7, 21), implying an independent low current consumption by each Programmable Non-Explosive Electronic Initiator (07).
- 5 11. - The Electronic Initiator, according to claim 1, WHEREIN the number of units connected in parallel of the Programmable Non-Explosive Electronic Initiator(s) (07) is limited to the current consumption of each Programmable Non-Explosive Electronic Initiator (07) multiplied by the number of Programmable Non-Explosive Electronic Initiator(s) (07) connected to the Communication and Power Line (02A, 02B), where this value is not greater than the current capacity delivered by the Command Equipment (01), where the maximum number of units connected in parallel is directly
10 proportional to the consumption of each Programmable Non-Explosive Electronic Initiator(s) (07) ranging from 10 to 30 milliAmperes per unit, where the activation of the maximum number of Programmable Non-Explosive Electronic Initiator(s) (07) units, connected in parallel, requires between 24V and 35V.
12. - A testing and exothermic reaction process of the Programmable Non-Explosive Electronic Initiator (07), as described
15 in claim 1, WHEREIN it comprises the following steps:
- i) check a communication failure between the Command Equipment (01) and the Programmable Electronic Non-Explosive Initiator(s) (07);
 - ii) check the initial charge of Capacitor (C7, 8, 21), where the final charge of Capacitor (C7, 8, 21) is checked, and
20 in case of error, transistor (T4, 22) is activated and capacitor (C7, 21) is forced to ground (Vss, GND);
 - iii) check the continuity of the Filament (30), where, in case of error, the transistor (T4, 22) is activated and forces the discharge to ground (Vss, GND) of the capacitor (C7, 21);
 - iv) check the delay time value programmed in the EEPROM memory of Microprocessor (IC1, 28);
 - v) Once stages i, ii, iii and iv have been checked, a command (6) initiates the following:
 - 25 vi) All the interrupts of Microprocessor (IC1, 28) are disconnected to avoid an early awakening of the sleep function;
 - vii) The load of Capacitor (C7, 21) is disconnected, so that it maintains its charge at maximum while Microprocessor (IC1, 28) is in "sleep" mode and TIMER1 counts down;
 - viii) Information related to the delay time stored in the non-volatile EEPROM memory of Microprocessor (IC1, 28)
30 is retrieved and the programmed delay time is loaded into the TIMER1 counter (Command 2);
 - ix) The "sleep" function of Microprocessor (IC1, 28) is enabled and only TIMER1 is kept running to start the delay time countdown;
 - x) The delay time countdown starts;
 - xi) Once the countdown reaches 0, the IO PORT (C5) is lifted, activating through resistor (R8) transistor (T2)
35 which, through the stored energy of capacitor (C7), discharges all its energy to ground passing through the filament (30) causing it to glow;
 - xii) Activation of the first rapidly expanding metallic mixture (13) through the filament being compressed with it by means of the Shrink Sleeve (14), with a temperature rise sufficient to activate the second rapidly expanding metallic mixture (15); and Exothermic reaction between the Programmable Non-Explosive Electronic Initiator
40 (07) and the rapidly expanding metal mixture and/or plasma.

Patentansprüche

- 45 1. Programmierbarer nichtexplosiver elektronischer Zünder (07) für ein schnell expandierendes Metallgemisch und/oder Plasma, WOBEI er Folgendes umfasst: eine Kapsel, die ein erstes schnell expandierendes Metallgemisch (13) und ein zweites schnell expandierendes Metallgemisch (15) angebracht enthält, mit Aktivierungstemperaturen über 1000 °C; wobei die Kapsel einem Behälterrohr oder einer Hülse (16) entspricht, das/die mit einem Abdichtstopfen (17) verschlossen ist; der ein Kommunikationsprotokoll basierend auf Spannungsmodulation (03) mittels einer Kommu-
50 nikations- und Stromleitung (02a, 02b) unter Verwendung eines bidirektionalen seriellen Algorithmus von einer externen Befehlseinrichtung (01) empfängt; einen Kondensator (C7, 8, 21) mit einer Spannungsanforderung unter 35 V, der mittels einer gesteuerten Entladung auf einem Filament (12, 30) das Filament zum Glühen bringt, wobei dieses Filament (12, 30) auf einer festen Basis (11) getragen wird, die mit dem ersten expandierenden metallischen Gemisch (13) bedeckt ist, das über 1000 °C aktiviert wird, wobei beide in eine Schrumpfhülse (14) eingesetzt sind, die sie
55 zusammenhält, wobei die Schrumpfhülse (14), die sie zusammenhält, wobei die Schrumpfhülse in dem Kapselbehälter (16) enthalten ist, der wiederum das zweite schnell expandierende metallische Gemisch (15) enthält, das über 1200 °C aktiviert wird; eine PCB-Leiterplatte (10) mit einer gedruckten PCB-Schaltung (9), die die Entladung steuert, deren Verzögerung zwischen 1 ms und 64.000 ms liegt, und deren Prüfen, so dass die Schaltung vor der Zündung

überprüft werden kann.

2. Elektronischer Zünder nach Anspruch 1, WOBEI die PCB-Leiterplatte (9) Folgendes umfasst: einen Mikroprozessor (IC1, 28), mit einem einzigartigen und nicht wiederholbaren Identifikationscode (ID), der die bidirektionale Kommunikation empfängt, die von der externen Befehlseinrichtung (01) kommt, und die verschiedenen Befehle verarbeitet, um den programmierbaren nichtexplosiven elektronischen Zünder (07) zu aktivieren, wo der Mikroprozessor (IC1, 28) ferner Folgendes umfasst: einen nichtflüchtigen EEPROM-Speicher, der den eindeutigen und nicht wiederholbaren Identifikationscode (ID) speichert, die Verzögerungsparameter und einen internen Oszillator, wobei ein PIN des Mikroprozessors (IC1, 28) als Eingang für die Signalverarbeitung dient, die als Anfangs- und Endladesensor des Kondensators (C7, 8, 21) fungiert und die Kontinuität des Filaments (30) erfasst, einen Flash-Mikrocontroller, eine Programmierereinheit (28F) des RAM-Speichers (44), der zum Mikroprozessor (IC1, 28) gehört; einen Kondensator (C4, 19), der die Stabilität und Autonomie der Eingangsspannung zum Mikroprozessor aufrechterhält, sobald der Auslösebefehl empfangen wird; einen externen Oszillator Q1 (25), der mit dem Mikroprozessor verbunden ist und eine niedrigere Oszillationsfrequenz als der interne Oszillator des letzteren aufzeigt, um die Impulse an einen ZEITGEBER (28A) des Mikroprozessors (IC1, 28) zu liefern.
3. Elektronischer Zünder nach Anspruch 2, WOBEI ein E/A-PORT-PIN (CO) im Mikroprozessor (IC1, 28), der mit zwei Widerständen (R5, R10) verbunden ist, den Transistor (T3) aktiviert, wobei die Ladung des Kondensators (C7, 8, 21) erzeugt wird.
4. Elektronischer Zünder nach Anspruch 2, WOBEI der Kondensator (C4, 19) eine hohe Kapazität mit Bereichen über 300 μ F, vorzugsweise 470 μ F Tantal, aufweist, wodurch die Stabilität der Eingangsspannung zum Mikroprozessor (IC1, 28) sowie das Energiereservoir aufrechterhalten werden, damit der Mikroprozessor während der programmierten Verzögerungszeit autonom bleibt, sobald der Auslöser aktiviert und die Kommunikations- und Stromleitung (02A, 02B) unterbrochen wurde.
5. Elektronischer Zünder nach Anspruch 2, WOBEI der externe Oszillator (Q1, 25) eine Frequenz von 32.000 Hertz aufweist, eine niedrigere Frequenz als der interne Oszillator des Mikroprozessors (IC1, 28), der mit dem Mikroprozessor (IC1, 28) verbunden ist, wobei ein Befehl den internen Oszillator des Mikroprozessors (IC1, 28) deaktiviert und den niederfrequenten externen Oszillator (Q1, 25) aktiviert, wobei die Aktivierung des externen Oszillators (Q1, 25) die Frequenz und den Stromverbrauch des Mikroprozessors (IC1, 28) um das 250- bis 500-Fache reduziert, wobei der externe Oszillator (Q1, 25) in Kombination mit der Aktivierung der "Sleep"-Funktion des Mikroprozessors (IC1, 28) den Stromverbrauch von mA auf nA reduziert, wodurch die maximal programmierbare Verzögerungszeit von 64.000 Millisekunden erreicht wird.
6. Elektronischer Zünder nach Anspruch 5, WOBEI der externe Oszillator (Q1, 25) der Agent ist, der Impulse für den ZEITGEBER1 aussendet, um die Impulse zu zählen und die Zeit zu bestimmen, wobei diese Informationen gespeichert werden und mittels Software zum Lesen verfügbar sind, wobei 32 Impulse, die vom externen Oszillator (Q1, 25) ausgesendet und vom ZEITGEBER1 gelesen werden, 1 Millisekunde entsprechen.
7. Elektronischer Zünder nach Anspruch 2, 5 und 6, WOBEI aufgrund des niedrigen Energieverbrauchs, der durch die Aktivierung des externen Oszillators (Q1, 25) erreicht wird, die Aktivierung der "Sleep"-Funktion des Mikroprozessors (IC1, 28) und die Autonomie des Kondensators (C4, 19) einen Sleep-Zustand von mehr als 64.000 Millisekunden erreichen, wobei die Verzögerungszeit von jedem programmierbaren nichtexplosiven elektronischen Zünder (07) programmierbar und auf einen Bereich zwischen 1 und 64.000 Millisekunden begrenzt ist.
8. Elektronischer Zünder nach Anspruch 1, WOBEI das Filament (30) eine Spiralform umfasst, deren Glühen eine hohe Temperatur erreichen kann, die das erste schnell expandierende Metallgemisch (13), das daran haftet, durch die vollständige Entladung des Kondensators (C7, 21) aktiviert.
9. Elektronischer Zünder nach Anspruch 1, WOBEI der programmierbare nichtexplosive elektronische Zünder (07), [07], die Kommunikations- und Stromleitung (02a, 02b) und die Befehlseinrichtung (01) über einen Rechteckwellen-Frame kommunizieren, wodurch der/die programmierbare(n) nichtexplosive(n) elektronische(n) Zünder (07) zeitlich synchronisiert sind.
10. Elektronischer Zünder nach Anspruch 2, WOBEI der Kondensator (C7, 21) mit 35 V und einem in Reihe mit dem Kondensator (C7, 21) geschalteten Widerstand (R9, 21) eine langsame Ladung des Kondensators (C7, 21) ermöglicht, was einen unabhängigen niedrigen Stromverbrauch durch jeden programmierbaren nichtexplosiven elektronischen Zünder (07) ermöglicht.

ischen Zünder (07) impliziert.

5 11. Elektronischer Zünder nach Anspruch 1, WOBEI die Anzahl der parallel geschalteten Einheiten des/der programmierbaren nichtexplosiven elektronischen Zünder(s) (07) auf den Stromverbrauch jedes programmierbaren nichtexplosiven elektronischen Zünder(s) (07) multipliziert mit der Anzahl der programmierbaren nichtexplosiven elektronischen Zünder (07) begrenzt ist, die an die Kommunikations- und Stromleitung (02A, 02B) angeschlossen sind, wobei dieser Wert nicht größer ist als die von der Befehlseinrichtung (01) gelieferte Stromkapazität, wobei die maximale Anzahl der parallel geschalteten Einheiten direkt proportional zum Verbrauch jedes programmierbaren nichtexplosiven elektronischen Zünder(s) (07) im Bereich von 10 bis 30 Milliampere pro Einheit ist, wobei die Aktivierung der maximalen Anzahl von parallel geschalteten Einheiten des/der programmierbaren nichtexplosiven elektronischen Zünder(s) (07) zwischen 24 V und 35 V erfordert.

10 12. Prozess zum Prüfen und zur exothermen Reaktion des programmierbaren nichtexplosiven elektronischen Zünder(s) (07) nach Anspruch 1, WOBEI er die folgenden Schritte umfasst:

- 15 i) Überprüfen eines Kommunikationsfehlers zwischen der Befehlseinrichtung (01) und dem/den programmierbaren nichtexplosiven elektronischen Zünder(n) (07);
 ii) Überprüfen der Anfangsladung des Kondensators (C7, 8, 21), wobei die Entladung des Kondensators (C7, 8, 21) überprüft wird und im Fehlerfall der Transistor (T4, 22) aktiviert und der Kondensator (C7, 21) zur Erdung (Vss, GND) gezwungen wird;
 20 iii) Überprüfen der Kontinuität des Filaments (30), wo im Fehlerfall der Transistor (T4, 22) aktiviert wird und die Entladung des Kondensators (C7, 21) zur Erdung (Vss, GND) gezwungen wird;
 iv) Überprüfen des im EEPROM-Speicher des Mikroprozessors (IC1, 28) programmierten Verzögerungszeitwerts;
 25 v) Nach dem Überprüfen der Stufen i, ii, iii und iv wird durch einen Befehl (6) Folgendes initiiert:
 vi) Alle Interrupts des Mikroprozessors (IC1, 28) werden getrennt, um ein vorzeitiges Aufwachen der Sleep-Funktion zu vermeiden;
 vii) Die Last des Kondensators (C7, 21) wird getrennt, sodass er seine Ladung maximal hält, während sich der Mikroprozessor (IC1, 28) im "Sleep"-Modus befindet und der ZEITGEBER1 herunterzählt;
 30 viii) Informationen, die die im nichtflüchtigen EEPROM-Speicher des Mikroprozessors (IC1, 28) gespeicherte Verzögerungszeit betreffen, werden abgerufen und die programmierte Verzögerungszeit wird in den ZEITGEBER1-Zähler geladen (Befehl 2);
 ix) Die "Sleep"-Funktion des Mikroprozessors (IC1, 28) wird aktiviert und nur ZEITGEBER1 läuft weiter, um das Herunterzählen der Verzögerungszeit zu starten;
 35 x) Das Herunterzählen der Verzögerungszeit beginnt;
 xi) Sobald das Herunterzählen 0 erreicht, wird der E/A-PORT (C5) angehoben, wobei über den Widerstand (R8) der Transistor (T2) aktiviert wird, der über die gespeicherte Energie des Kondensators (C7) seine gesamte Energie über das Filament (30) zur Erde entlädt, wodurch es zum Glühen gebracht wird;
 40 xii) Aktivieren des ersten schnell expandierenden metallischen Gemischs (13) durch das Filament, das mit ihm mittels der Schrumpfhülse (14) komprimiert wird, mit einem Temperaturanstieg, der ausreicht, um das zweite schnell expandierende metallische Gemisch (15) zu aktivieren; und exotherme Reaktion zwischen dem programmierbaren nichtexplosiven elektronischen Zünder (07) und dem schnell expandierenden metallischen Gemisch und/oder Plasma.

45 **Revendications**

50 1. Initiateur électronique programmable non explosif (07) pour un mélange de métaux et/ou un plasma à expansion rapide, DANS LEQUEL il comprend une capsule, contenant, liés, un premier mélange de métaux à expansion rapide (13) et un second mélange de métaux à expansion rapide (15) avec des températures d'activation supérieures à 1000 °C ; où la capsule correspond à un tube ou à un manchon (16) de conteneur qui est fermé avec un bouchon (17) ; qui reçoit un protocole de communication basé sur une modulation de tension (03), au moyen d'une ligne de communication et d'alimentation (02a, 02b) à l'aide d'un algorithme série bidirectionnel provenant d'un équipement de commande externe (01) ; un condensateur (C7, 8, 21), avec une exigence de tension inférieure à 35 V qui, au moyen
 55 d'une décharge contrôlée sur un filament (12, 30) fait briller le filament, où ce filament (12, 30) repose sur une base solide (11) recouverte du premier mélange métallique expansif (13) qui est activé à plus de 1000 °C, dans lequel les deux sont insérés dans un manchon rétractable (14) qui les maintient ensemble, dans lequel le manchon rétractable (14), qui les maintient ensemble, où le manchon rétractable est contenu à l'intérieur du conteneur de capsule (16) qui

EP 4 239 278 B1

contient à son tour le second mélange métallique à expansion rapide (15) activé à plus de 1 200 °C ; une carte de circuit imprimé PCB (10) avec un circuit imprimé PCB (9) qui contrôle la décharge, sa temporisation entre 1 ms et 64 000 ms et son test afin que le circuit puisse être vérifié avant l'allumage.

- 5 **2.** Initiateur électronique selon la revendication 1, DANS LEQUEL la carte de circuit imprimé PCB (9) comprend un microprocesseur (IC1, 28), avec un code d'identification (ID) unique et non reproductible, qui reçoit la communication bidirectionnelle provenant de l'équipement de commande externe (01) et traite les différentes commandes pour activer l'initiateur électronique non explosif programmable (07), où le microprocesseur (IC1, 28) comprend en outre une mémoire EEPROM non volatile, qui stocke le code d'identification unique et non reproductible (ID), les
10 paramètres de temporisation et un oscillateur interne, où un PIN du microprocesseur (IC1, 28) sert d'entrée pour le traitement de signal fonctionnant comme capteur de charge initiale et finale de condensateur (C7, 8, 21) et détectant la continuité de filament (30), un microcontrôleur flash, une unité de programmation (28F) de mémoire RAM (44) appartenant au microprocesseur (IC1, 28) ; un condensateur (C4, 19) qui maintient la stabilité et l'autonomie de la tension d'entrée du microprocesseur une fois que la commande de déclenchement est reçue ; un oscillateur externe
15 Q1 (25) connecté au microprocesseur avec une fréquence d'oscillation inférieure à celle de l'oscillateur interne de ce dernier pour fournir les impulsions à un TEMPORISATEUR (28A) du microprocesseur (IC1, 28).
- 3.** Initiateur électronique, selon la revendication 2, DANS LEQUEL une BROCHE DE PORT E/S (CO) dans le microprocesseur (IC1, 28) qui est connectée à deux résistances (R5, R10), active le transistor (T3) produisant la
20 charge du condensateur (C7, 8, 21).
- 4.** Initiateur électronique, selon la revendication 2, DANS LEQUEL que le condensateur (C4, 19) a une capacité élevée avec des plages supérieures à 300 µF, de préférence 470 µF de tantale, maintenant la stabilité de la tension d'entrée du microprocesseur (IC1, 28) ainsi que le réservoir d'énergie pour permettre au microprocesseur de rester autonome
25 pendant la période de temporisation programmée une fois que le déclencheur a été activé et que la ligne de communication et d'alimentation (02A, 02B) sont interrompues.
- 5.** Initiateur électronique, selon la revendication 2, DANS LEQUEL l'oscillateur externe (Q1, 25) a une fréquence de 32 000 Hertz, une fréquence inférieure à celle de l'oscillateur interne du microprocesseur (IC1, 28), connecté au microprocesseur (IC1, 28), où une commande désactive l'oscillateur interne de microprocesseur (IC1, 28) et active
30 l'oscillateur externe à basse fréquence (Q1, 25), où l'activation d'oscillateur externe (Q1, 25) réduit la fréquence et la consommation d'énergie du microprocesseur (101, 28) de 250 à 500 fois, où l'oscillateur externe (Q1, 25) en combinaison avec l'activation de la fonction « veille » du microprocesseur (101, 28), réduit la consommation d'énergie de mA à nA, ce qui permet d'atteindre le délai de temporisation maximum programmable de 64 000 millisecondes.
35
- 6.** Initiateur électronique, selon la revendication 5, DANS LEQUEL l'oscillateur externe (Q1, 25) est l'agent émettant des impulsions pour que le TEMPORISATEUR1 compte ces impulsions et détermine le délai, ces informations sont stockées et peuvent être lues au moyen d'un logiciel, où 32 impulsions émises par l'oscillateur externe (Q1, 25) et lues
40 par le TEMPORISATEUR1 sont équivalentes à 1 milliseconde.
- 7.** Initiateur électronique, selon les revendications 2, 5 et 6, DANS LEQUEL en raison de la faible consommation d'énergie obtenue grâce à l'activation de l'oscillateur externe (Q1, 25), l'activation de la fonction « veille » du microprocesseur (IC1, 28) et l'autonomie du condensateur (C4, 19), atteignent un état de veille de plus de 64 000 millisecondes, où le délai de temporisation est programmable à partir de chaque initiateur électronique programmable
45 non explosif (07) et limité à une plage comprise entre 1 et 64 000 millisecondes.
- 8.** Initiateur électronique, selon la revendication 1, DANS LEQUEL le filament (30), comprend une forme de spirale, dont l'incandescence est capable d'atteindre une température élevée qui active le premier mélange de métaux à expansion rapide (13) qui y est adhérent, par le biais de la décharge complète du condensateur (C7, 21).
50
- 9.** Initiateur électronique, selon la revendication 1, DANS LEQUEL l'initiateur électronique programmable non explosif (07), [07], la ligne de communication et d'alimentation (02a, 02b) et l'équipement de commande (01) communiquent par le biais d'une trame d'ondes carrées, maintenant le(s) déclencheur(s) électronique(s) programmable(s) non explosif(s) (07) synchronisé(s) dans le temps.
55
- 10.** Initiateur électronique, selon la revendication 2, DANS LEQUEL le condensateur (C7, 21) de 35V et avec une résistance (R9, 21) connectée en série avec ledit condensateur (C7, 21), permet une charge lente de condensateur (C7, 21), ce qui implique une faible consommation de courant indépendante par chaque initiateur électronique

programmable non explosif (07).

5 11. Initiateur électronique, selon la revendication 1, DANS LEQUEL le nombre d'unités connectées en parallèle à ou aux initiateur(s) électronique(s) non explosif(s) programmable(s) (07) est limité à la consommation de courant de chaque initiateur électronique non explosif programmable (07) multiplié par le nombre d'initiateur(s) électronique(s) non explosif(s) programmable(s) (07) connectés à la ligne de communication et d'alimentation (02A), 02B), où cette valeur n'est pas supérieure à la capacité actuelle fournie par l'équipement de commande (01), où le nombre maximal d'unités connectées en parallèle est directement proportionnel à la consommation de chaque initiateur électronique programmable non explosif (07) allant de 10 et 30 milliampères par unité, où l'activation du nombre maximal d'unités d'initiateur(s) électronique(s) programmable(s) non explosif(s) (07), connectés en parallèle, nécessite entre 24 V et 35 V.

10 12. Processus de test et de réaction exothermique de l'initiateur électronique non explosif programmable (07), tel que décrit dans la revendication 1, DANS LEQUEL il comprend les étapes suivantes :

15 i) vérifier une défaillance de communication entre l'équipement de commandement (01) et le(s) initiateur(s) électronique(s) non explosif(s) programmable(s) (07) ;

20 ii) vérifier la charge initiale du condensateur (C7, 8, 21), où la charge finale du condensateur (C7, 8, 21) est vérifiée, et en cas d'erreur, le transistor (T4, 22) est activé et le condensateur (C7, 21) est forcé à la terre (Vss, GND) ;

25 iii) vérifier la continuité du filament (30), où, en cas d'erreur, le transistor (T4, 22) est activé et force la décharge à la terre (Vss, GND) du condensateur (C7, 21) ;

30 iv) vérifier la valeur du délai de temporisation programmée dans la mémoire EEPROM du microprocesseur (IC1, 28) ;

35 v) Une fois que les étapes i, ii, iii et iv ont été vérifiées, une commande (6) déclenche ce qui suit :

vi) Toutes les interruptions de microprocesseur (IC1, 28) sont déconnectées pour éviter un réveil prématuré de la fonction veille ;

30 vii) La charge du condensateur (C7, 21) est déconnectée, de manière à ce qu'il maintienne sa charge au maximum pendant que le microprocesseur (IC1, 28) est en mode « veille » et que le TEMPORISATEUR1 effectue un compte à rebours ;

35 viii) Les informations relatives au délai de temporisation stockées dans la mémoire EEPROM non volatile du microprocesseur (IC1, 28) sont récupérées et le délai de temporisation programmé est chargé dans le compteur TEMPORISATEUR1 (commande 2) ;

40 ix) La fonction « veille » de microprocesseur (IC1, 28) est activée et seule le TEMPORISATEUR1 est maintenu en marche pour démarrer le compte à rebours du délai de temporisation ;

x) Le compte à rebours du délai de temporisation commence ;

45 xi) Lorsque le compte à rebours atteint 0, le PORT IO (C5) est levé, l'activation par le biais du résistor (R8) du transistor (T2) qui, à travers l'énergie stockée dans le condensateur (C7), décharge toute son énergie à la terre en passant par le filament (30), ce qui le fait briller ;

50 xii) Activation du premier mélange métallique à expansion rapide (13) par le biais de la compression de filament avec lui au moyen du manchon rétractable (14), avec une augmentation de température suffisante pour activer le second mélange métallique en expansion rapide (15); et réaction exothermique entre l'initiateur électronique programmable non explosif (07) et le mélange de métaux et/ou le plasma en expansion rapide.

45

50

55

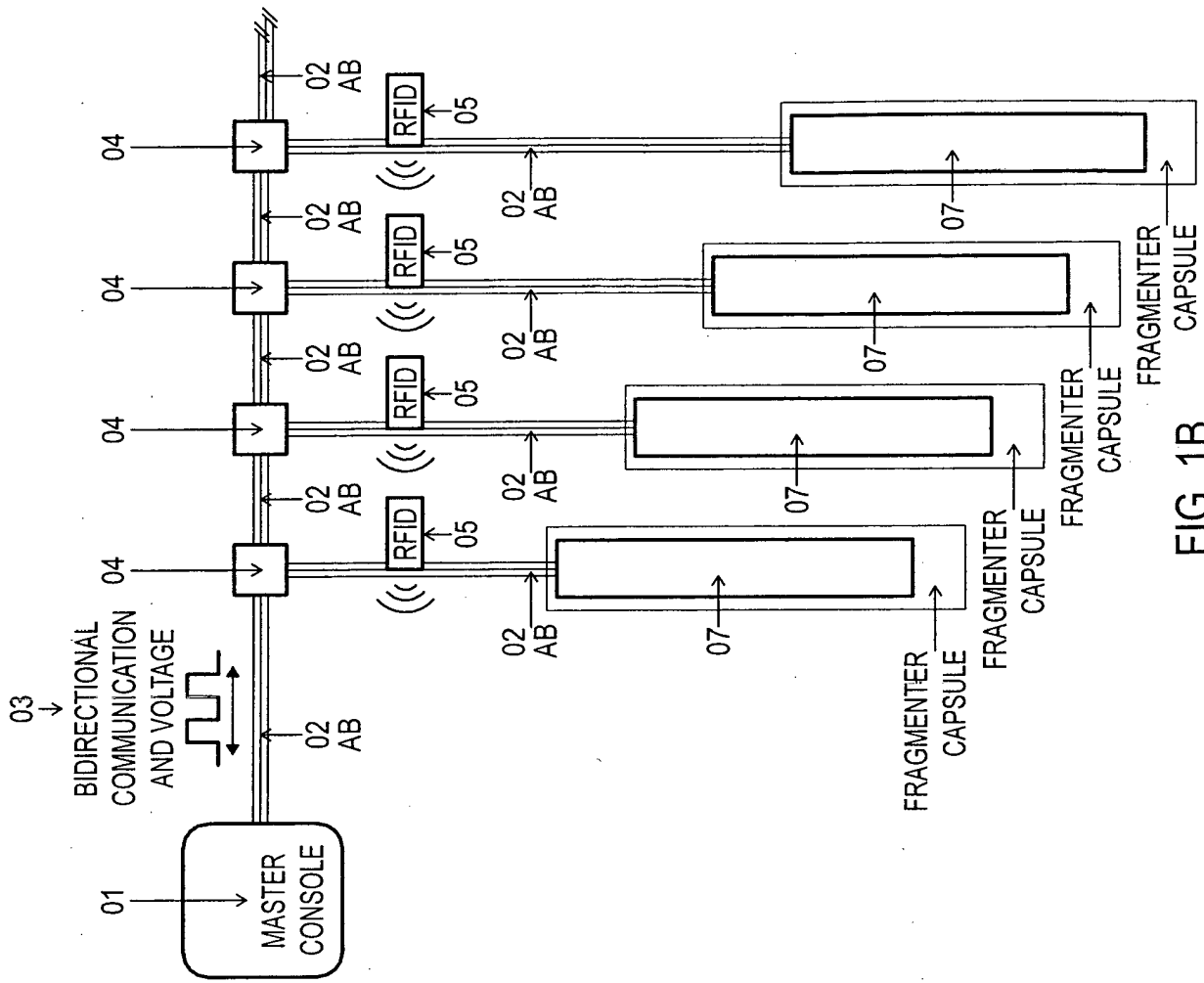

FIG. 1B

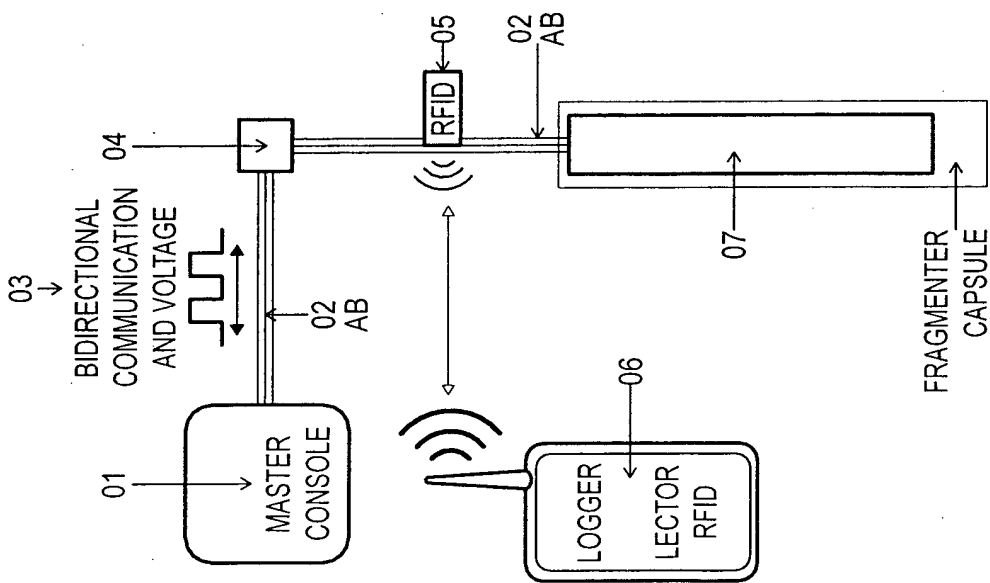

FIG. 1A

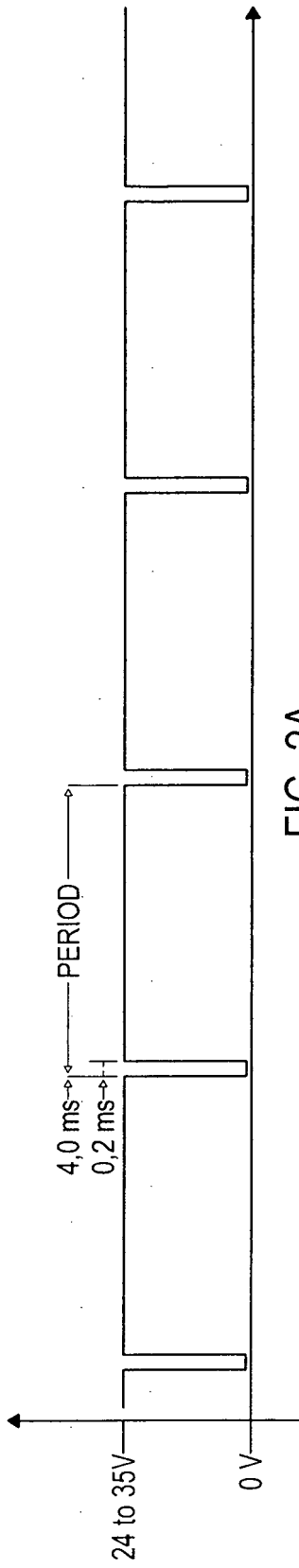

FIG. 2A

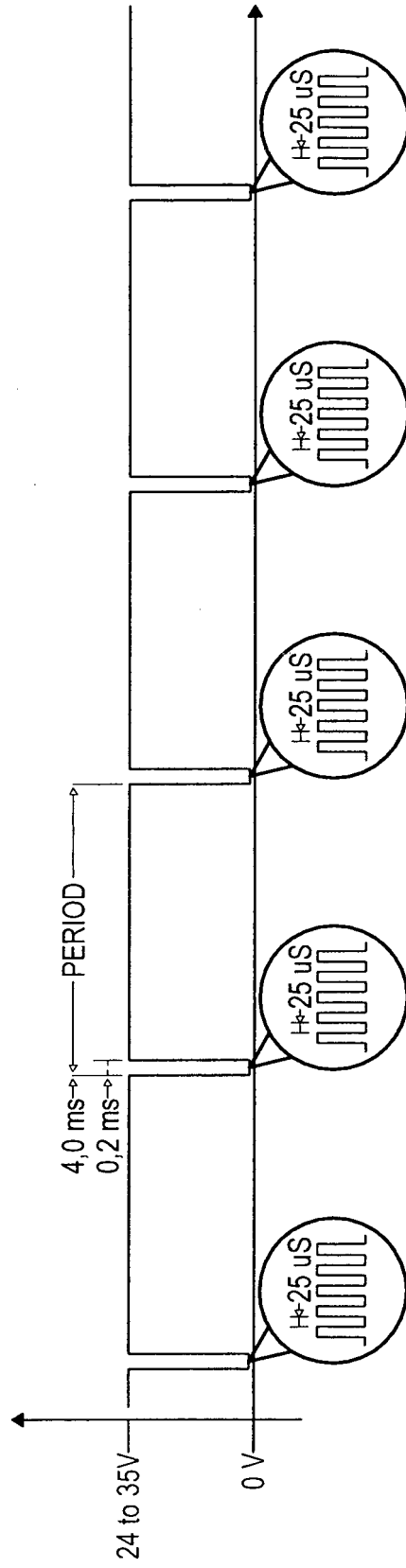

FIG. 2B

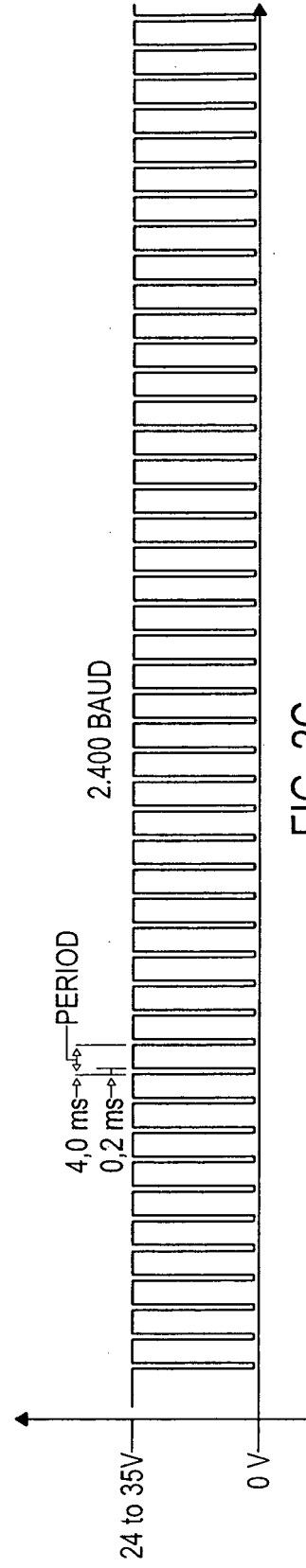

FIG. 2C

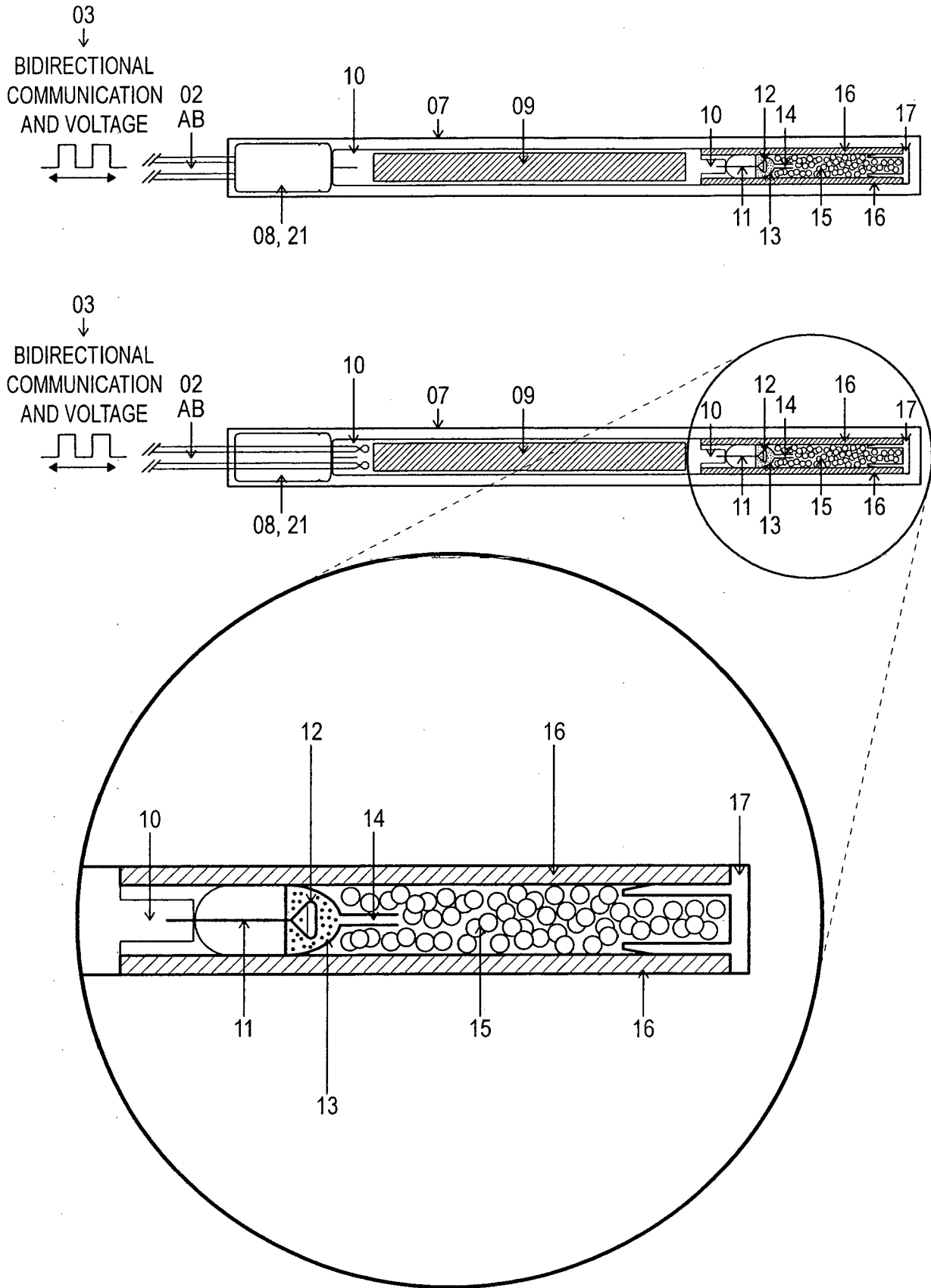

FIG. 3

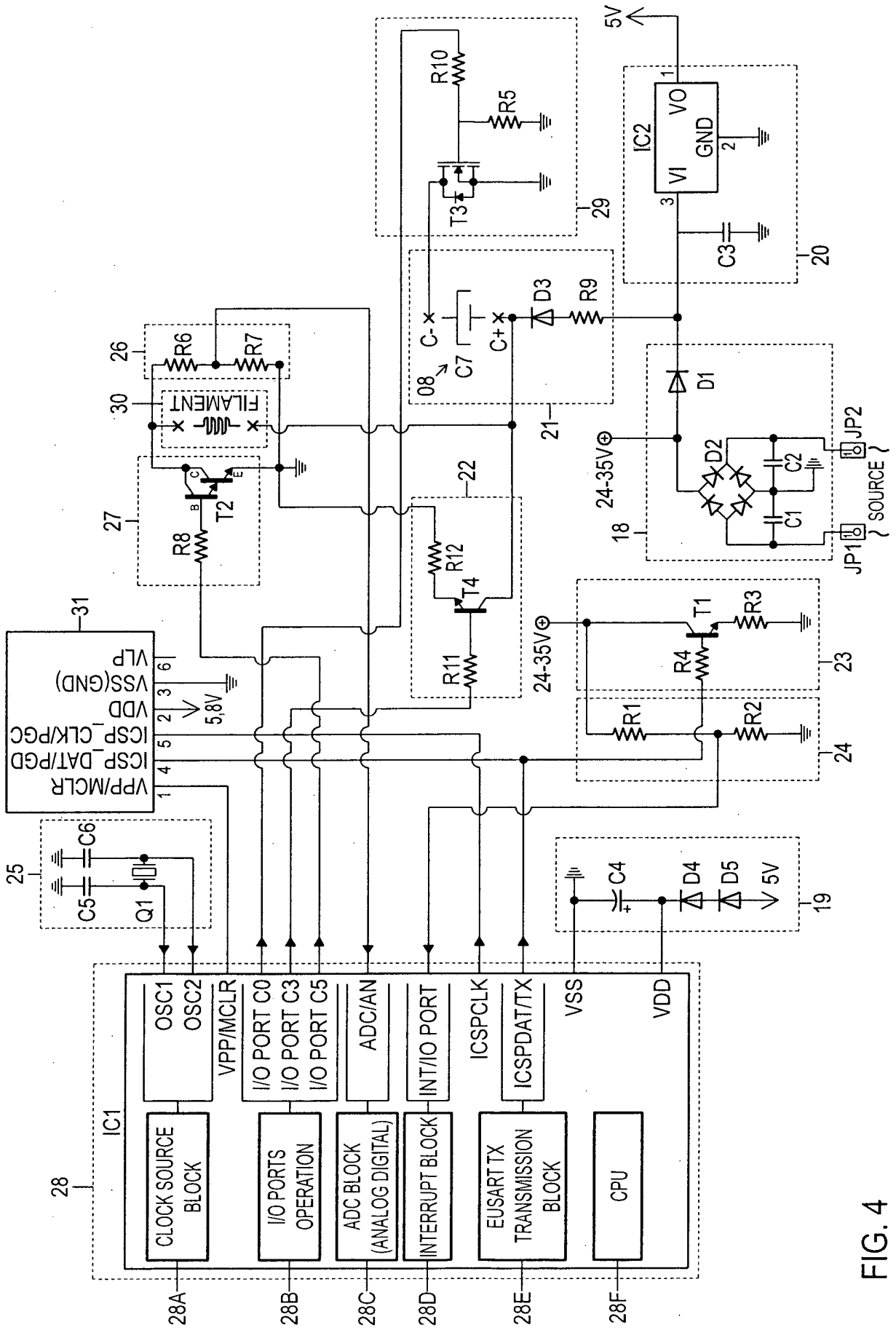

FIG. 4

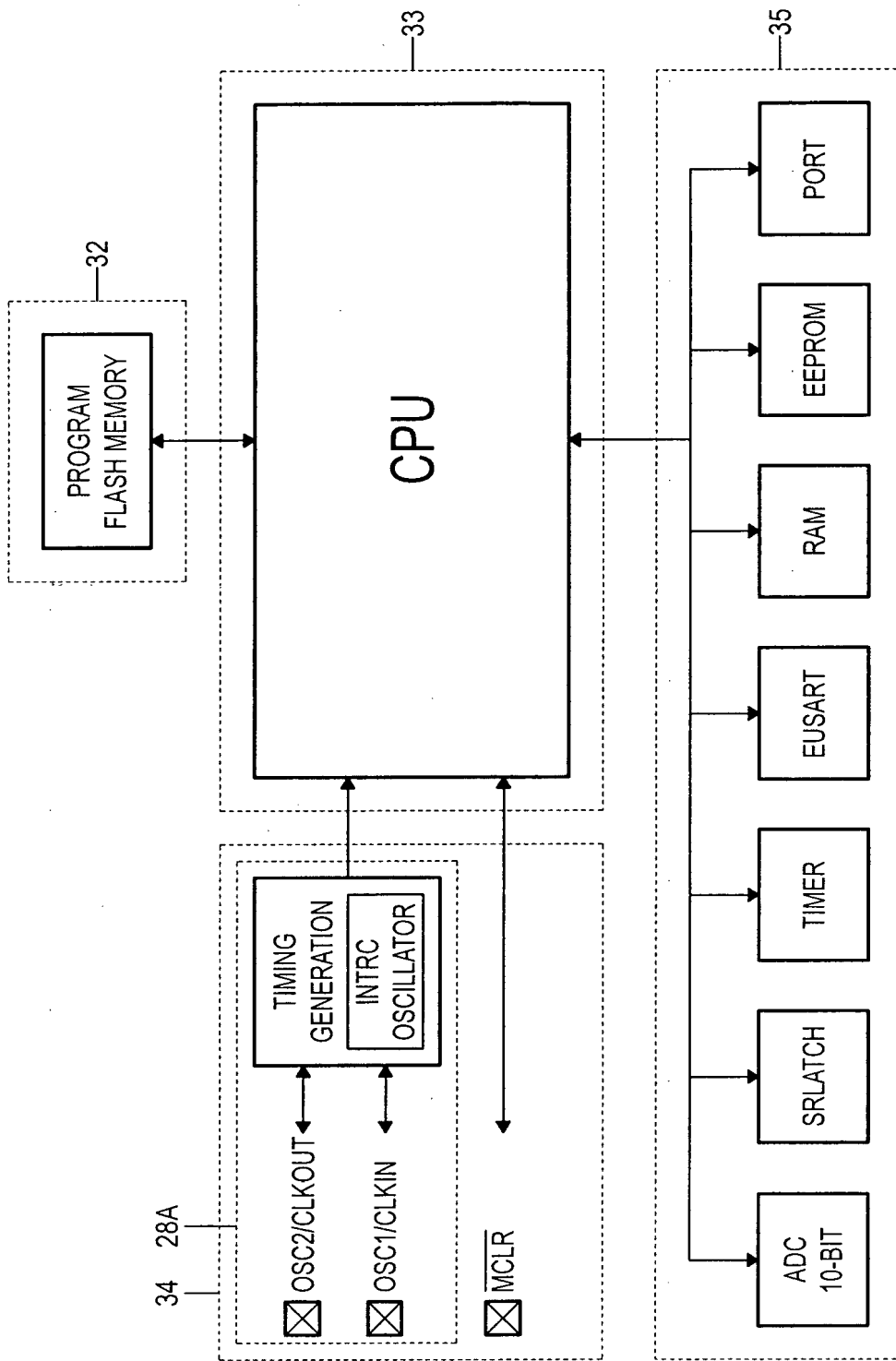

FIG. 5

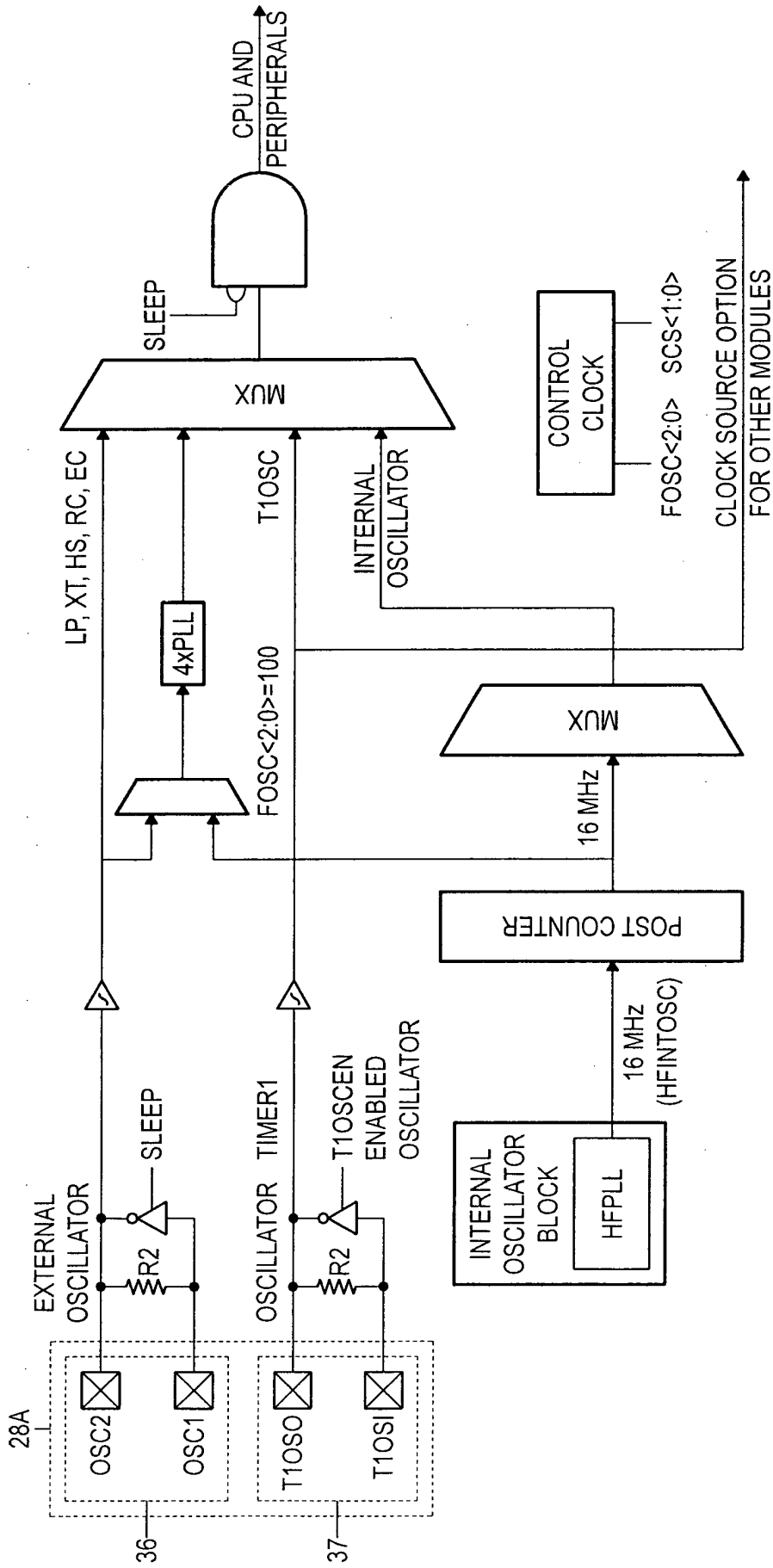

FIG. 6

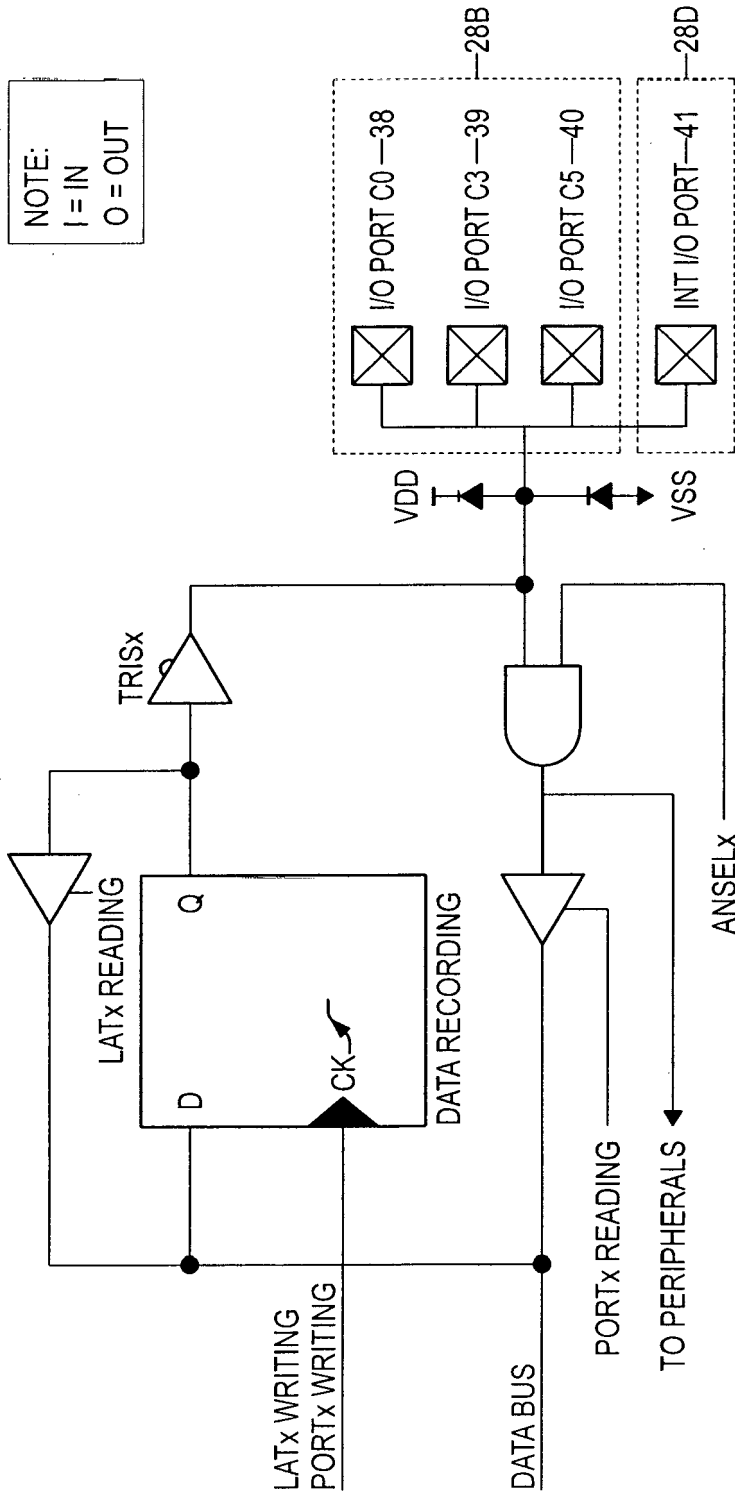

FIG. 7

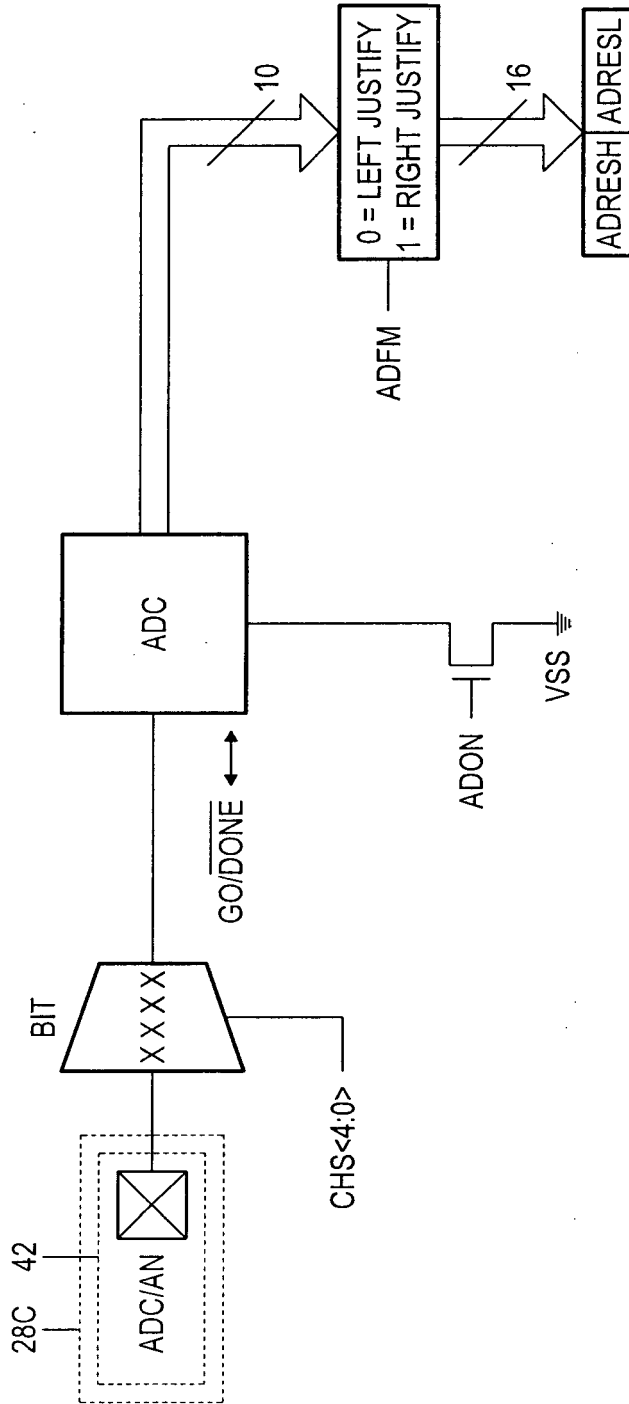

FIG. 8

REFERENCES CITED IN THE DESCRIPTION

This list of references cited by the applicant is for the reader's convenience only. It does not form part of the European patent document. Even though great care has been taken in compiling the references, errors or omissions cannot be excluded and the EPO disclaims all liability in this regard.

Patent documents cited in the description

- DE 102005052578 [0008]
- US 61108277 [0009]
- EP 1105693 A [0010]
- WO 0009967 A [0010] [0052]
- EP 12706936 A [0011]
- EP 2678633 A [0011]
- ES 2540573T3 [0011]
- US 6173651 B1 [0012]
- US 4674047 A1 [0013]
- KR 100213577 [0015]
- WO 100213577 A [0016] [0065]
- EP 1306642 B1 [0023] [0024] [0026] [0034] [0039] [0040] [0043] [0051]
- US 6173651 B [0035]
- EP 1105693 B1 [0035]
- WO 0009967 A1 [0035]
- US 5171935 A [0042]
- CA 2339167 C [0042]
- US 8746144 B2 [0042]