

Jan. 28, 1969

W. C. TRIPLETT

3,424,253

METHOD FOR DRILLING AND WORKING IN OFFSHORE WELLS

Filed Dec. 3, 1956

Sheet 1 of 3

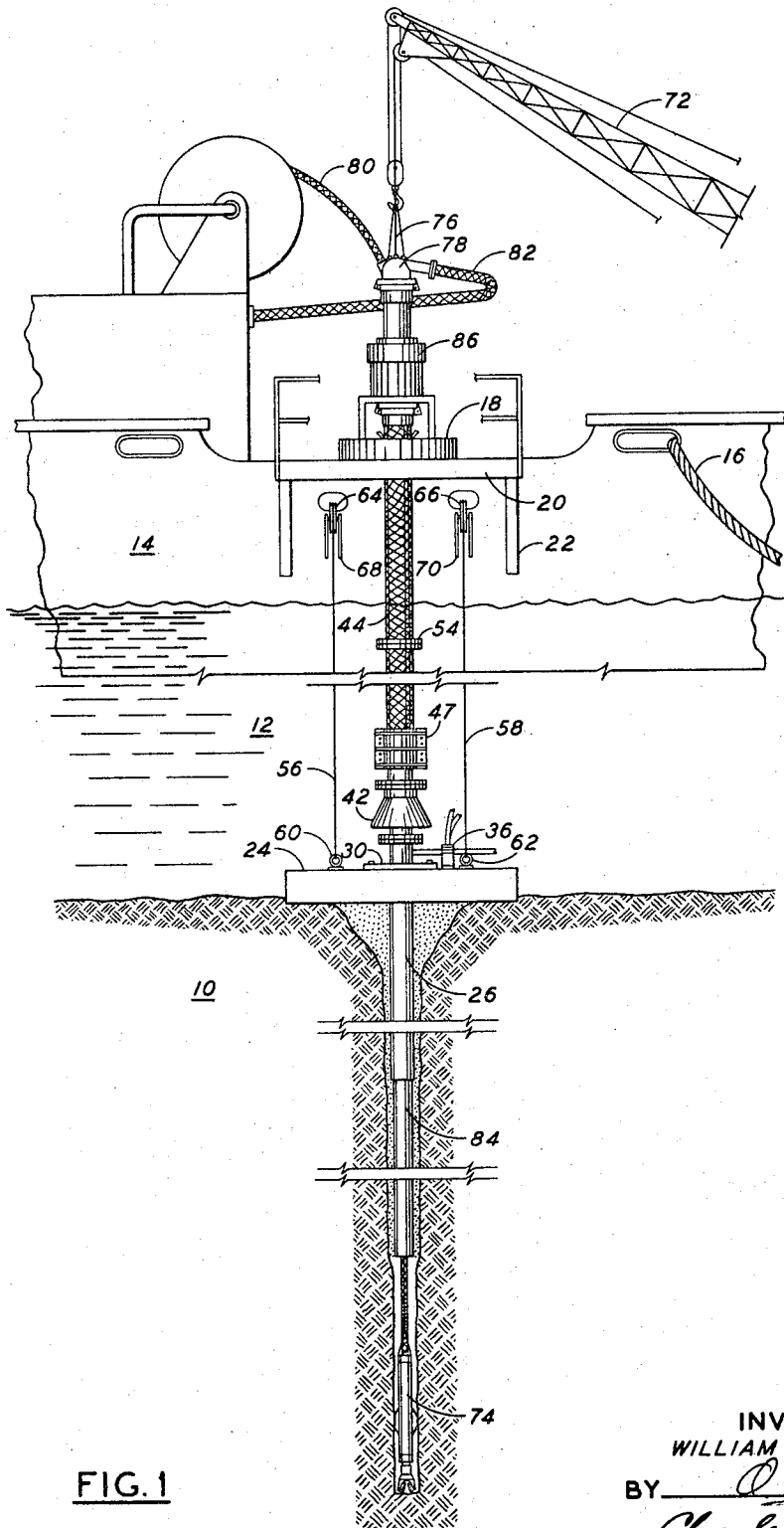

FIG. 1

INVENTOR
WILLIAM C. TRIPLETT
BY *O. L. Lund*
Charles E. Gibson
ATTORNEYS

Jan. 28, 1969

W. C. TRIPLETT

3,424,253

METHOD FOR DRILLING AND WORKING IN OFFSHORE WELLS

Filed Dec. 3, 1956

Sheet 2 of 3

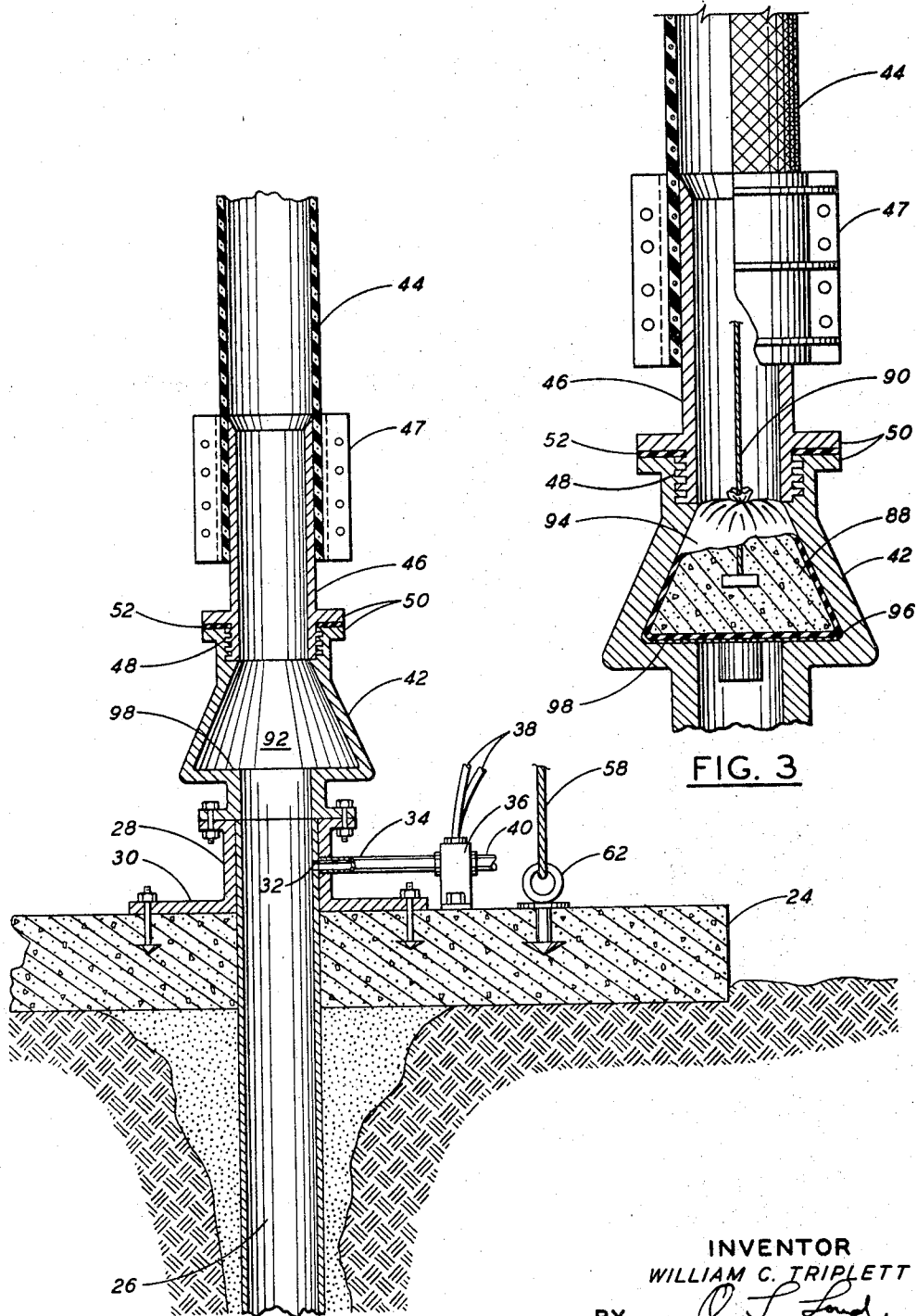

FIG. 2

FIG. 3

INVENTOR
WILLIAM C. TRIPLETT
BY *Charles J. Gibson*
ATTORNEYS

Jan. 28, 1969

W. C. TRIPLETT

3,424,253

METHOD FOR DRILLING AND WORKING IN OFFSHORE WELLS

Filed Dec. 3, 1956

Sheet 3 of 3

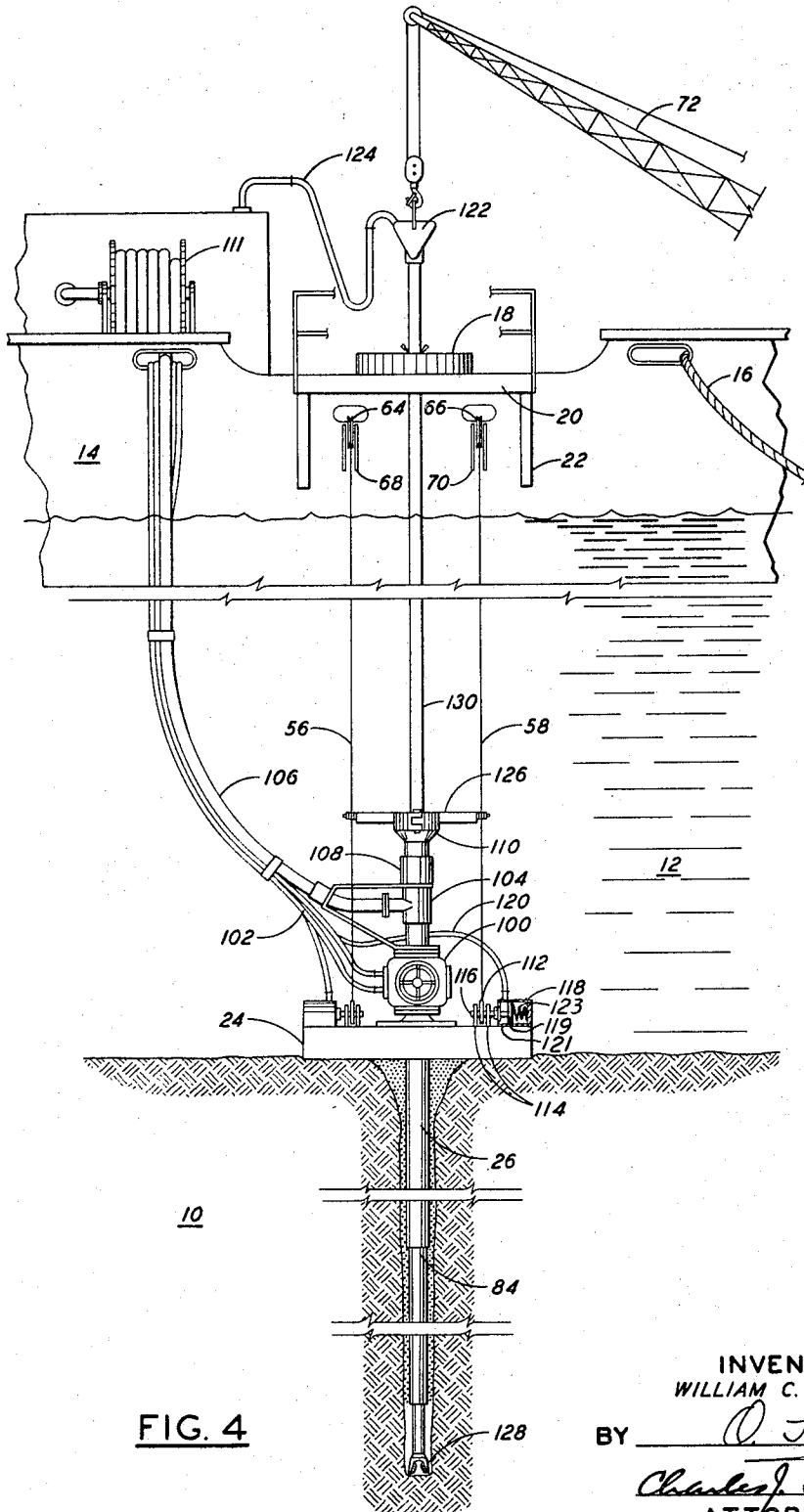

FIG. 4

INVENTOR
WILLIAM C. TRIPLETT

BY Charles J. Gibean
ATTORNEYS

1

2

3,424,253

METHOD FOR DRILLING AND WORKING IN OFFSHORE WELLS

William C. Triplett, Corpus Christi, Tex., assignor to Chevron Research Company, a corporation of Delaware

Filed Dec. 3, 1956, Ser. No. 625,682
U.S. Cl. 175-7
Int. Cl. E21b 15/02; B63b 5/44

4 Claims

ABSTRACT OF THE DISCLOSURE

Methods of drilling and working on wells in submerged formations entailing the use of conduit means extending from a submerged well head to a floating vessel, the jetting-in of a casing attached to well head equipment, the cementing in of casing, and the guiding of drilling equipment.

General background, objects and summary of invention

This invention relates to a method for drilling oil wells in locations submerged under water and more particularly to a method and apparatus for drilling offshore wells from a floating vessel while providing means detachable from the vessel to control the opening of the well by well head equipment submerged in and at the bottom of the water at the well site.

The problem of drilling offshore wells is one which has received much attention and various methods and equipment previously have been proposed for this purpose. The problem has added difficulties when the well site is in deep water and especially in open waters where strong winds, large waves and sudden storms create conditions hazardous to men and equipment. It is desirable in offshore drilling that some means be provided to control the opening of the well in such a manner that the well control apparatus will not be susceptible to damage or malfunctioning because of the natural forces which may occur at the environment of the well site. Together with this, it is desirable that some means be provided for readily disconnecting the drilling vessel from the controlled well so that it can move on to other drilling sites.

It will be appreciated that a sudden storm may require the drilling vessel to leave the well site immediately. Therefore, it is also desirable in these circumstances that some means be provided expeditiously to close the opening of the well in a fluid-tight manner by apparatus free from the hazard of storm damage so that the drilling vessel can abandon the well site to ride out the storm.

It is an object of this invention to provide a novel drilling method which employs a very mobile floating drilling vessel to drill wells in submarine locations.

It is another object of this invention to provide a method for drilling an oil well in subterranean formations located under a body of water and for controlling the flow of fluids into and out of the oil well by well head control apparatus located at the bottom of and submerged in the water.

It is a further object of this invention to provide means for rapidly disconnecting the floating drilling vessel from the well site so that it can be moved away therefrom while leaving the well controlled by the well head equipment at the bottom of the body of water.

Still another object of this invention is to provide for submarine drilling purposes, well head control equipment which is submerged in and at the bottom of the body of water, and secured to the bottom at the well site, by which the opening of the well can be controlled, to eliminate a hazardous condition which arises by having the well head control equipment at the surface of the water, or submerged in the water at some point vertically

displaced from the bottom thereof, and connected to the well by an exposed string of casing.

Other objects of this invention will become apparent as the description of it proceeds hereinafter in conjunction with the accompanying drawings which form part of this specification.

Drawings of preferred embodiments

In the drawings:

FIG. 1 illustrates in elevation a combination of apparatus employed in the method of this invention.

FIG. 2 illustrates in sectional elevation details of parts of the apparatus employed in the method illustrated in FIG. 1.

FIG. 3 illustrates partly in sectional elevation a detail of the operating procedure employed with the apparatus illustrated in FIG. 1.

FIG. 4 illustrates in elevation and partly in section another combination of apparatus employed in the method of this invention.

Referring to the embodiment of the invention illustrated in FIG. 1, the numeral 10 indicates the earth formations into which it is desired to drill a well. These earth formations underlie a body of water 12, which may be several hundreds of feet in depth.

When the offshore site has been selected into which it is desired to drill a well a vessel 14, which may be a boat or a barge for example, is floated over the well site and anchored in position by a plurality of anchors. The numeral 16 indicates an anchor cable attached to one such anchor.

The vessel has mounted on it the power sources, derrick, rotary table, pumps, tanks and other equipment normally used in a rotary drilling operation. In the illustrated embodiment of the invention the rotary table 18 is supported on the platform 20 which extends over a side of the vessel and is supported by a bracket structure 22. The table is placed on the platform so that it is centered several feet away from the side of the vessel for a purpose to be explained hereinafter.

When the vessel is thus positioned, a landing base or platform structure 24 is lightered into place below the platform 20. The base structure will form the positioning means for the well head control equipment which is to be landed on and positioned at the bottom of the water at the well site.

The landing base has integrally attached to and extending from the bottom of it a length of rigid conductor casing 26 which eventually will be sunk vertically into the topmost portions of the earth formations underlying the body of water to prevent these formations from caving into the hole as drilling proceeds. The length of the conductor casing therefore will be determined by the nature and thickness of the uppermost strata of the earth formations. As shown in FIG. 2, the upper portion of the conductor casing extends through the landing base and into a cylindrical projection 28 of a flanged element 30 to which it is fastened in a unitary manner, as by welding. The flanged element is securely fastened to the landing base. A radially directed opening 32 is formed through the wall of cylindrical projection 28 and also through the wall of a portion of the conductor casing extended into it. One end of a conduit 34 is secured in this radial opening in a fluid-tight manner, and the other end is affixed to a valve 36. This valve preferably is of a type which can be remotely controlled from a position at the surface of the water. Remotely operable hydraulic, electric or manually controlled valves are available which are suitable for this installation, and the valve structure per se is not a part of this invention. The valve control lines are indicated by the numeral 38.

The outlet side of the valve 36 is connected to a sec-

ond conduit 40 by which production from the well can be conducted to storage tanks on vessels floating on the surface of the water or, if the environment permits, to land installations. Preferably the conduit 40 is a flexible pipe line made, for example, of a rubber casing reinforced with steel wire.

Attached to the top of the projection 28 is, in this embodiment of the invention, an element 42 which permits the opening of the well to be controlled at the bottom of the water in a manner to be explained hereinafter. The topmost portion of the element 42 has detachably attached to it one end of a flexible conductor casing 44. This flexible casing may be made, for instance, of steel-reinforced rubber. One end of casing 44 is attached to the end of a section of rigid steel casing 46 and a clamp 47 may be used to make a physically strong connection between the parts. The bottom portion of section 46 has formed on it screw threads 48 which mate with and are received by complementary screw threads formed in the upper portion of element 42. Complementary flanges 50 may be formed on the adjacent parts of casing section 46 and element 42 with a packing material interposed between them to assist the mating screw threads in making a physically strong fluid-tight connection.

The flexible conductor casing 44 is made in sections of a length to be handled conveniently and the sections are joined together by flanges 54 to provide a continuous flexible conductor casing which will extend from the well head equipment fixed at the bottom of the water to the deck of the drilling vessel. The flexibility of conductor string 44 will permit the boat to move relative to the fixed well head equipment.

The structure of the landing base and its size will be governed to a great degree by the nature of the bottom into which the well is to be drilled. If the bottom is relatively firm, the landing platform need be only of such size that it will seat on the bottom and bridge the opening of the hole formed when the rigid conductor casing is jetted into the earth formations at the bottom of the water. In this environment the landing base will rest on the topmost surface of the submarine earth formations and serve to position the wellhead control equipment at the bottom of the water, free from being submerged in the mud or silt at the bottom. If the earth formation at the bottom of the water is soft or silty, the landing platform will be made larger so that it will have more surface area to support the well head control equipment in the desired position without permitting it to sink into the bottom silt. If the bottom is very muddy or silty, the landing platform may be made with inner chambers of controllable buoyancy and of such size that the required amount of buoyancy can be maintained in the base to keep the well head control equipment from sinking into the bottom prior to the time surface casing is set and cemented in place to hold it in the desired position.

With the well head equipment assembled on the landing base as explained heretofore and with the flexible conductor casing attached to the well head equipment the apparatus is ready to be lowered into the water. Cables 56 and 58 are attached to the eyes 60 and 62 respectively, which are secured to the landing platform. The cables run over respective sheaves 64 and 66 which are mounted on the side of the vessel on respective bracket structures 68 and 70 so that they will be spaced away from the side to give the landing base and well head control equipment clearance when they are supported from the cables while being lowered into the water. The cables 56 and 58 are attached to suitable power winches aboard the vessel. Thus, the landing platform and the equipment assembled on it can be lifted from the lighter and lowered into the water.

As the well head assemblage is lowered into the water, sections of flexible conductor casing are attached to the conductor casing string 44 so that the upper end of the casing remains above and out of the water. Preferably

the conductor string 44 is inserted through the rotary table so that the casing joints 54 can be made up on the platform 20. The casing string is then lowered into the water by the hoist mechanism 72 as the well head control equipment descends, and slips can be employed to secure the casing to the table if this becomes desirable.

When the lowermost portion of the rigid conductor casing 26 rests on the bottom an appropriate hole forming apparatus such as, for example, a string of tubing of at least sufficient flexibility to accommodate the curvature of the flexible conduction casing and to the end of which jetting nozzles are attached is inserted through the flexible conductor casing string which guides it downwardly through the well head apparatus until it is in contact with the bottom. When jetting nozzles are used rigid conductor casing 26 is then jetted into the subterranean earth formations by a pressure fluid forced down the tubing from aboard the vessel. The jetting will continue until the landing base 24 rests on the bottom, at which time the rigid conductor casing 26 will have been inserted into the earth formations the desired distance. When other hole forming apparatus is used a hole of sufficient diameter and depth to receive the conductor casing is formed below it, and the conductor casing is lowered into the hole until the landing base 24 rests at the bottom of the water. Sections are added to the flexible conductor casing string as the rigid conductor casing is lowered into position so that the topmost portion of the flexible conductor casing remains inserted through the rotary table.

When the base 24 is landed, the jetting apparatus is withdrawn and the conductor casing 26 is cemented in place by cement introduced by a cementing tool such as a tubing inserted through the flexible conductor casing, the well head equipment and the lower rigid conductor casing 26 in a manner comparable to that commonly used in land practice and well known to the drilling art.

While the cement is setting, it is advisable to slack off the cables 56 and 58 and preferably to release them from the landing base. This may be done by a diver if the water is shallow, or if the water is too deep for divers to operate in, an automatic device such as shown in FIG. 4, and to be explained later, may be used. Sufficient slack is placed in the flexible conductor string so that the heaving of the vessel due to water motion will not move the landing base and assembled well head equipment from its position on the bottom.

When the cement has set, a self-contained drilling mechanism 74 such as a turbo drill or an electric drill is inserted into the upper end of the flexible conductor casing string which guides it down into the well. The drilling mechanism is supported by a wire line 76 from the hoisting apparatus 72. The wire line runs slidably through an opening in a head member 78 mounted on the upper end of the flexible casing string. The opening is sealed in a manner to permit the wire line to be lowered into or withdrawn from the well while maintaining a fluid-tight connection at the head member. When a turbo drill is employed, a flexible hose 80 which also runs slidably through the head member in a fluid-tight manner is used to conduct the pressurized motive fluid to the drill. In the case of an electric drill, the same means is employed to permit the electrical conductors and mud hose to run slidably through the head member. The drilling mud and cuttings from the well return upwardly through the conductor casing and are taken from the head member by mud line 82.

When drilling is to proceed, the uppermost portion of flexible conductor casing string 44 is lowered through the rotary table until there is enough slack in it to take care of the motions of the ship without pulling the string taut. The upper portion of the string is then supported in the rotary table, as by slips, the function and operation of which are well known in drilling practice. The drilling mechanism is lowered on the wire line 76 and it is guided into the well by the conductor casing 44. When it is in

contact with the earth formations at the bottom of the rigid conductor casing string 26, it is put into operation and drilling proceeds.

In the initial drilling a bit is used with a reamer to drill a hole large enough to accept a string of surface casing 84. The hole is drilled to a depth to accept a predetermined length of surface casing, determined by the nature of the subterranean formations to which the surface casing will be anchored and by the depth of the well it is desired to drill. The surface casing will act as the principal anchoring means for the well head control equipment, securing it to the bottom against high well pressures. When the hole for the surface casing has reached the desired depth, the drilling mechanism is withdrawn from the hole and the casing strings, head member 78 is removed from the top of the flexible casing, and the drilling mechanism is withdrawn entirely from the casing. The topmost portion of the flexible conductor casing is now open to permit sections of surface casing to be made up into a string and lowered into it. It is desirable now to dismount the upper portion of the flexible casing string from the rotary table and suspend it below the platform 20 with its open end centered below the rotary table. The casing string is supported by cables connected to an appropriate ring fastened to the top portion of it and the cables are run over the sheaves 64 and 66 and wound on the winches aboard the vessel. When this is done, the rotary table is free to be used to make up the string of surface casing 84 as it is lowered into the well. A string of predetermined length is made up and lowered on a wire line through the flexible conductor casing which guides it into the well and is hung in the rigid conductor casing string 26 by casing hangers in a manner well known in drilling practice. The surface casing string is then cemented into place, the cement being squeezed up into contact with the rigid conductor casing string 26 and into the annulus between the casing 26 and the surface casing 84.

When the cement is set the drilling mechanism is again inserted into the flexible conductor casing string 44, the head member 78 is secured in place, and the drilling proceeds.

When oil formations at high pressure or high pressure gas pockets will be penetrated by the drill, it is desirable to place a blowout preventer 86 in the top portion of the flexible conductor casing string to assist in maintaining control of the well.

When the well has been drilled to the desired depth the usual well completion procedure is followed.

It is now desired to close the opening of the well at the submerged well head control apparatus. This is accomplished by lowering a mass of cement slurry 88 on a wire line 90 through the flexible conductor casing until it rests in the chamber 92 of element 42. Preferably the cement is contained in a flexible metal basket formed of interleaved spring metal segments, the use of which is well known in the art. The cement slurry may be confined in a plastic sack 94 within the basket to insure its remaining in a compact mass. When the basket reaches the chamber 92 the spring metal segments will expand outwardly as shown by the numeral 96, FIG. 3, to engage with the bottom portion 98 of the chamber and hence hold the cement slurry localized in the chamber. When the basket has reached this position, drilling mud under pressure is applied to the top of it to force the cement slurry to conform with the configuration of the inner walls of chamber 92. Thus, when the cement has set, the opening from the well will be closed in a fluid-tight manner at element 42.

The flexible conductor casing 44 is now detached from the well head assembly. This is accomplished by removing the equipment from the top of the flexible conductor casing string and securing the upper portion of it in the rotary table 18. The table is then rotated to unscrew the flexible conductor casing from the top of the element 42 at the screw threaded connection 48. As has been men-

tioned previously, the cables 56 and 58 have been disconnected from the landing platform; therefore, the drilling vessel is now completely detached from the well.

The wire line 90 by which the cement plug 88 was lowered into element 42 has been left attached to the plug and, when the flexible conductor casing is withdrawn from the well head, the upper end of the wire line is attached to a buoy which will float on the surface of the water. Thus, the position of the well is marked. The wire line 90 will serve as a means for guiding the flexible conductor casing down to the well head assembly if subsequently it is desired to open the well for reworking or other purposes.

The control lines 38 to the remotely operated valve 36 are also buoyed on the surface when the vessel is detached from the well, so that they may again be picked up and used to operate the valve to control the flow of fluids from the well.

It is apparent that the apparatus described heretofore permits the drilling vessel to be quickly detached from the well if emergency conditions such as a sudden storm requires it to be free to leave the well site. The drilling mechanism employed can be quickly withdrawn from the well by the hoist mechanism and the flexible hose 80 wound back on its reel in much less time than is required to withdrawn drill tubing. The flexible conductor casing 44 is then free to be disconnected as explained heretofore. If time permits, a packer will be lowered on the wire line 90 through the flexible conductor casing prior to disconnecting it and anchored in the element 42 to close the well opening. The wire line will be buoyed at the surface and serve as a means for locating the well site and guiding the flexible conductor casing down to the well head assembly when the well is to be reopened.

FIG. 4 exemplifies another embodiment of the apparatus which may be employed in the method of this invention. The same numerals will be used in the description of FIG. 4 as were used in previous figures to identify comparable parts of the equipment.

In this embodiment, a landing base 24 has attached to the bottom of it a length of rigid conductor casing 26 in the manner described previously for the embodiment shown in FIG. 1.

On top of the landing base is mounted a control element 100 which permits the opening of the well to be closed and which can be operated remotely from aboard the drilling vessel. This control element may be a valve such as is exemplified in the publication "Limitorque Control," catalog L-550, Philadelphia Gear Works, or the publication, "Pneumatic-Hydraulic Power Operated Nordstrom Valves," Bulletin V-214, 1951, Rockwell Manufacturing Company, Pittsburgh, Pa., a blowout preventer, or, if circumstances require, a plurality of valves and blowout preventers mounted in series on top of the landing base. The numeral 102 indicates the operating lines to the control element. Mounted on top of the control element is a connection 104 for a mud return hose 106, and on top of that is attached a drilling head 108. The drilling head has a funnel 110 affixed to the top of it for a purpose to be described hereinafter.

The cables 56 and 58 which are used to lower the landing base to the bottom of the water in a manner previously explained in conjunction with FIG. 1 are attached to the landing base by remotely controlled, detachable connections in the embodiment of the invention illustrated in FIG. 4. These connections take the form of an eye 112 at the end of each cable, and each eye fits within a clevis 114. A pin 116 is inserted through the clevis and eye, and one end of the pin is connected to a motor 118 for withdrawing it from the clevis. As exemplified herein, the motor may take the form of a hydraulic unit comprising a piston 119 within a cylinder 121 and in which a spring 123 biases the pin outwardly in a position to be inserted through the clevis and the eye. When a hydraulic fluid under pressure is applied to the motor

through the line 120, the motor will withdraw the pin and hence cause the cable to be detached from the landing platform.

The valve control lines and the mud return hose are attached to the well head equipment prior to lowering it into the water, and are wound on drums 111 aboard the vessel. Rotary coupling connections are used on the drums so that the lines and mud hose have continuous communication with the appropriate equipment aboard the vessel and with the well head apparatus.

When the landing base is suspended in the water by the cables 56 and 58 and has assumed a vertical position under the center of the rotary table, an appropriate hole forming apparatus such as, for example, a string of drill tubing having jetting nozzles or a drill bit attached to its lower end is lowered through the rotary table and through the well head control apparatus. As the landing base is lowered into the water, the drill string will be lowered in conjunction with it so that when the end of the rigid conductor casing 26 comes in contact with the firmer underwater earth formations the jetting nozzles or drill bit will be in a position to form a hole into which the casing is lowered until the landing base is seated on the bottom. It will be appreciated that a swivel head 122 will be attached to the topmost portion of the tubing string to receive a hose 124 through which the jetting or drilling fluid can be forced down the tubing string to create the jetting or drilling action desired. The tubing string will be supported at its topmost portion by a hoist 72 in a manner well known to the art.

When the landing base is in place on the bottom the tubing string is withdrawn from the casing and well head equipment. As it is withdrawn, a guide member 126 will abut a collar near the end of the string and will travel upwardly with it. This guide member in cooperation with the cables 56 and 58 serves as a means for guiding casing, tubing or tools to the submerged well head equipment. The funnel 110 will act as a centering means to guide the element through the well head equipment and into the well. This guiding equipment is now used to guide a cementing tool such as string of tubing and packers through the well head equipment and into the conductor casing string 26. Cement is forced down through the tubing to cement the conductor casing in place in a manner analogous to the usual field practice. The cables 56 and 58 are slacked off while the cement is setting, so that the landing base will not be moved from its position.

When the cement is set, a drill 128 at the end of a string of drill tubing 130 is guided by the cables 56 and 58 and guide member 126 through the well head equipment and thence into contact with the earth formations at the bottom of the conductor casing. The drill string is rotated by the rotary table in the usual manner to drill a hole of predetermined size and depth to accept a string of surface casing 84. Drilling mud circulation is maintained through the drill tubing and the mud return line 106. During drilling, it is desirable to place enough slack in cables 56 and 58 so that the motion of the drilling vessel acting through the cables will not disturb the position of the landing platform and submerged well head equipment. Alternatively, the cables after passing over the sheaves 64 and 66 may have counterweights attached to their inboard ends and hence be free of any rigid attachment to the vessel, so that the vessel may move without affecting the stress placed on them.

If emergency conditions, such as sudden storms, arise which require the vessel to be detached from the well quickly while drilling is progressing and if there is not sufficient time to withdraw the drill string from the well without hazard to the men and equipment aboard the drilling vessel, the drill string is disconnected and dropped through the rotary table, and the guide lines 56 and 58 are disconnected at the remotely controlled connections 118. It is a relatively simple matter to cast off the valve control lines and mud hose to free the vessel from the well

site. Preferably, if time permits, the ends of the castoff lines will be buoyed at the surface so that they can be picked up again to locate the well site.

Prior to casting off the lines the control element 100 will have been closed, and if blowout preventers are employed on the well head equipment, they preferably will be of the known type wherein the pressure of the well fluids acting against the backs of the rams will hold them in a closed position. Thus, the opening of the well will be close down when the vessel leaves the well site.

The particular embodiment of the invention illustrated in FIG. 4 is designed for use primarily for drilling exploratory wells; therefore, details of the apparatus used for taking production from a flowing well have not been illustrated. However, it is believed apparent that the side take-off conduit 34, valve 36 and pipe line 40 of the apparatus illustrated in FIG. 1 can be incorporated with that shown in FIG. 4 to achieve this result if this embodiment of the invention is used to drill a development well.

There are many advantages in having the well head control equipment submerged at the bottom of the water. In this position, it is free from the hazard of damage due to rough water and the large wave forces generated by storms. Furthermore, when it is so located, it will not form a navigation hazard nor be in a position to be damaged by the impact of debris forced against it by water currents. Still further, this installation eliminates a necessity of having lengths of casing exposed in the water connecting the well with the well control equipment and exposed to the risk of damage or rupture.

It is obvious that other modifications than those illustrated may be made, employing the inventive concept without departing from it; therefore, it is desired that this invention need not be limited by the specific exemplary embodiments illustrated therein, but that it includes all equivalents within the scope of the appended claims.

I claim:

1. The method of drilling and working on a well in earth formations submerged under water by the operation of apparatus controlled solely at the surface of the water comprising anchoring a floating drilling vessel at the surface of a body of water above a submerged well site, supporting from said vessel on cables a landing base to the bottom of which is affixed a length of rigid conductor casing projecting vertically downwardly from said landing base, rigidly affixing to the top of said landing base wellhead control equipment having an opening therethrough and including means permitting said opening to be closed, connecting in a fluid-tight manner the lower end of a string of flexible conductor casing to said wellhead control equipment to communicate through said opening in said wellhead control equipment with the interior of said length of rigid conductor casing, inserting a string of tubing from said vessel through said string of flexible conductor casing and said landing base and said length of rigid conductor casing, attaching jetting nozzles to the lower end of said string of tubing and a source of jetting fluid under pressure to the upper end thereof aboard said vessel to form hole forming jetting apparatus, lowering said cables from said vessel while maintaining the upper end of said string of flexible conductor casing aboard said vessel and projecting said length of rigid conductor casing into the earth formations submerged under said body of water by operation of said jetting apparatus from said vessel until said landing base contacts the submerged land surface to support said length of rigid conductor casing in a fixed position relative to said earth formations and place said wellhead control equipment submerged in and at the bottom of said body of water, withdrawing said string of tubing and said jetting nozzles to aboard said vessel, cementing said length of rigid conductor casing to the wall of the surrounding earth by a cementing tool lowered from said vessel through said string of flexible conductor casing and into

said length of rigid conductor casing to form with said length of rigid conductor casing the upper end portion of a well with said opening through said wellhead control equipment forming the opening of said well, withdrawing said cementing tool and inserting a drilling mechanism through said string of flexible conductor casing, said wellhead control equipment, said landing base and said length of rigid conductor casing, drilling a well in said submerged earth formations with said drilling mechanism while remotely controlling said drilling mechanism from said floating vessel, withdrawing said drilling mechanism from said well and said wellhead control equipment, and closing the opening of said well at said wellhead control equipment by remote operation from said vessel of the said means in said wellhead control equipment.

2. The method of drilling and working in earth formations submerged under water by the operation of apparatus controlled at the surface of the water comprising anchoring a floating vessel at the surface of the water above a well site, lowering from said vessel on cables to a position adjacent the bottom of the water well head control equipment attached to a landing base having a conductor casing projecting from the bottom thereof and with an opening through said well head control equipment and said landing base in axial alignment with said conductor casing, guiding a hole forming apparatus downwardly from said vessel and into alignment with said opening through said well head control equipment by flexible guide means connected to said vessel and to said landing base, lowering said hole forming apparatus through said well head control equipment and said conductor casing and forming a hole in the submerged earth below said conductor casing with said hole forming apparatus controlled from said vessel, lowering said conductor casing into said hole, guiding by said flexible guide means a cementing tool downwardly from said vessel to said opening in said well head control equipment and lowering said cementing tool through said conductor casing, operating said cementing from said vessel and cementing said conductor casing to the walls of said hole to secure said landing base and said well head control equipment to the underwater bottom with said conductor casing forming the upper portion of a well and said opening through said well head control equipment forming the opening at the upper end of the well, lowering a drilling mechanism from said vessel and guiding said drilling mechanism by said flexible guide means through said opening in said well head control equipment, lowering said drilling mechanism through said conductor casing and into contact with the submerged earth formations, drilling a well in said submerged earth formations with said drilling mechanism controlled from said floating vessel, withdrawing said drilling mechanism from said well and said well head control equipment, operating said well head control equipment from said vessel to close said opening of said well, prior to the completing of said well, lowering additional casing from said floating vessel, guiding said additional casing, by said flexible guide means, downwardly from said vessel, through said opening in said well head control equipment and into said conductor casing, and cementing said additional casing and said conductor casing in mutually fixed relation below said water surface.

3. The method of drilling and working in a well in

earth formations submerged under water by the operation of apparatus controlled from a floating vessel located on the surface of the water above a well site comprising anchoring a drilling vessel at the surface of a body of water above a submerged well site, lowering from said vessel to the bottom of and submerged in the water at said well site a landing base having a length of conductor casing extending vertically from the bottom thereof and to the top of which is fixedly attached well head control equipment having a vertically-disposed opening therethrough and including a remotely operable means for selectively closing and opening said opening, said opening forming the top opening of said conductor casing, guiding a hole forming apparatus downwardly from said vessel to said opening through said well head control equipment by flexible guide means connected to said vessel and to said well head control equipment, lowering said hole forming apparatus through said well head control equipment and said conductor casing and forming a hole in the submerged earth below said conductor casing with said hole forming apparatus controlled from said vessel, lowering said conductor casing into said hole, guiding by said flexible means a cementing tool downwardly from said vessel and to said opening in said well head control equipment and lowering said cementing tool through said conductor casing, operating said cementing tool from said vessel and cementing said conductor casing to the walls of said hole to secure said landing base and said well head control equipment to the underwater bottom with said conductor casing forming the upper portion of a well and said opening through said well head control equipment forming the opening at the upper end of the well, lowering a drilling mechanism from said vessel and guiding said drilling mechanism through said opening in said well head control equipment while said drilling vessel is moving with said surface of said water, lowering said drilling mechanism through said conductor casing and into contact with the submerged earth formations, drilling a well into said submerged earth formations while controlling said drilling mechanism from said vessel, withdrawing said drilling mechanism from said well and said well head control equipment, closing said opening in said well head control equipment by the operations thereof from said vessel, prior to the completing of said well, lowering additional casing from said floating vessel, guiding said additional casing, by said flexible guide means, downwardly from said vessel, through said opening in said well head control equipment and into said conductor casing, and cementing said additional casing and said conductor casing in mutually fixed relation below said water surface.

4. The method of drilling and working on a well in earth formations submerged under water by the operation of apparatus controlled solely at the surface of the water comprising anchoring a floating vessel at the surface of a body of water above a submerged well site, lowering from said surface of said water and positioning at the bottom of and submerged in said body of water at said well site well head control equipment having an opening therethrough and having means included therein permitting the closing of said opening by remote operation from said vessel, attaching said well head control equipment to the submerged earth formations at said bottom by a con-

11

ductor casing connected to said well head control
 equipment in communication with said opening and
 lowered from said vessel and inserted in a hole
 formed below said well head control equipment by
 hole forming apparatus operated from said surface
 of said water and by cementing said conductor casing
 5 to the walls of said hole by means of a cementing
 tool operated from said surface of said water,
 providing conduit means extending between said vessel
 and said well site, said conduit means defining flexible
 10 guide means operable to guide a drilling mechanism
 from said vessel to said opening in said well head
 control equipment while said vessel is moving with
 said surface of said body of water and relative to said
 well head control equipment,
 15 lowering said drilling mechanism from said vessel
 through said conduit means and guiding said drilling
 mechanism by said conduit means through said well
 head control equipment and into contact with the
 submerged earth formations, drilling a well into said
 20 submerged earth formations by said drilling mech-
 anism controlled from said vessel with said conductor
 casing forming the upper portion of said well and
 said opening through said well head control equip-
 ment forming the opening of said well,
 25 withdrawing said drilling mechanism from said well and
 said well head control equipment,
 closing said opening of said well at said means in said
 well head control equipment by operation of said
 means from said vessel,

12

providing means operated from said floating vessel to
 detach the said conduit means from said well head
 control equipment,
 prior to the completing of said well, lowering additional
 casing from said floating vessel,
 5 guiding said additional casing, by said conduit means,
 downwardly from said vessel, through said opening
 in said well head control equipment and into said
 conductor casing, and
 10 cementing said additional casing and said conductor
 casing in mutually fixed relation below said water
 surface.

References Cited

UNITED STATES PATENTS

Re. 24,083	11/1955	McNeill	175—7
2,512,783	6/1950	Tucker	175—6
2,669,431	2/1954	Crowell	175—1
20 2,808,229	10/1957	Bauer et al.	175—7
2,808,230	10/1957	McNeill et al.	175—7
1,173,355	2/1916	Jones	61—53.74
1,853,379	4/1932	Rotinoff.	
2,187,871	1/1940	Voorhees	175—8
25 2,676,787	4/1954	Johnson	175—7
2,891,770	6/1959	Bauer et al.	175—7

CHARLES E. O'CONNELL, *Primary Examiner.*30 R. E. FAVREAU, *Assistant Examiner.*