

J. H. McBRIDE.
 COIN CONTROLLED APPARATUS.
 APPLICATION FILED JULY 14, 1910.

973,364.

Patented Oct. 18, 1910.

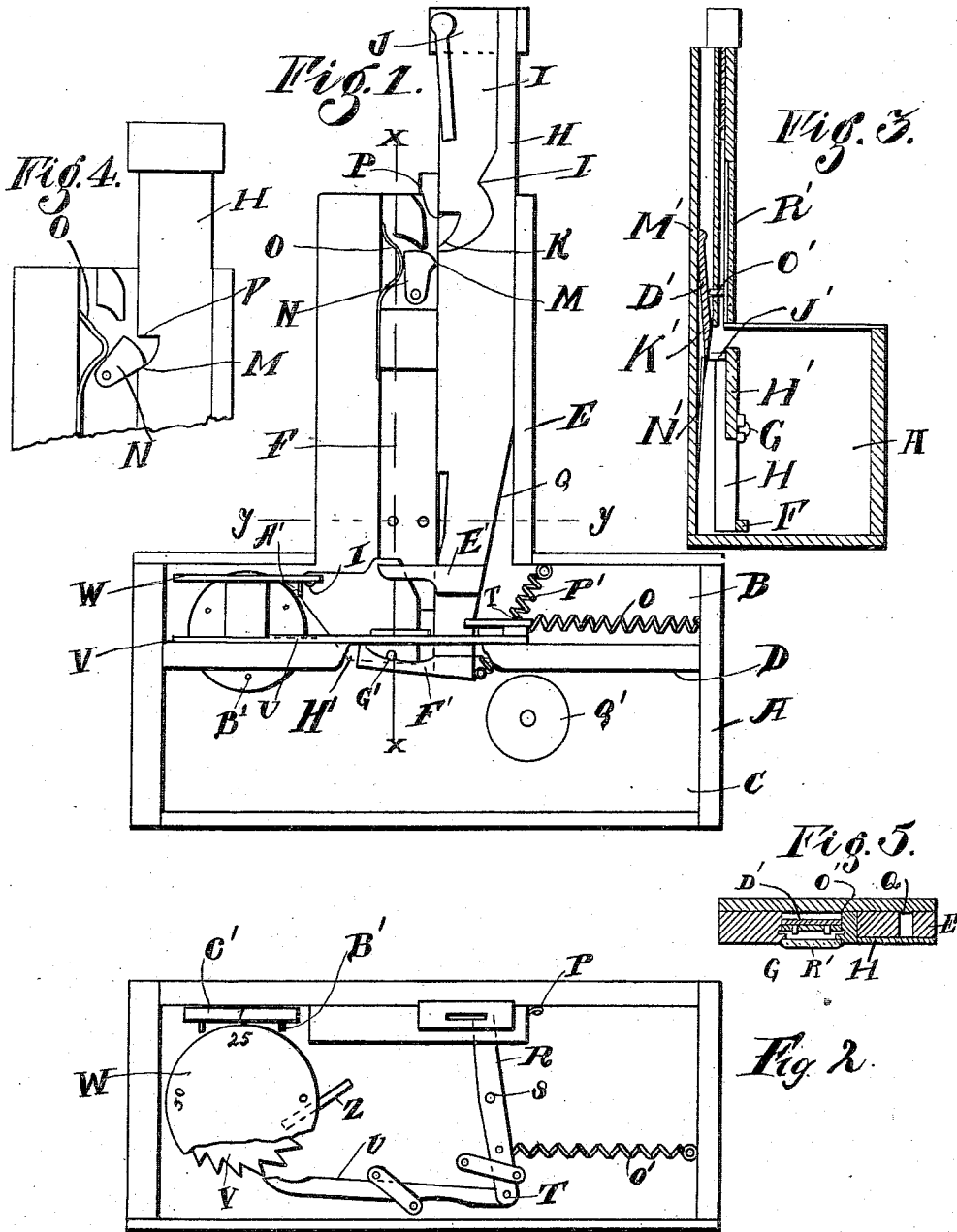

WITNESSES

Francis Woodcock
S. M. Gallagher

INVENTOR

Joseph H. McBride
 BY
W. H. Williamson

ATTORNEY

UNITED STATES PATENT OFFICE.

JOSEPH H. McBRIDE, OF PHILADELPHIA, PENNSYLVANIA.

COIN-CONTROLLED APPARATUS.

973,364.

Specification of Letters Patent.

Patented Oct. 18, 1910.

Application filed July 14, 1910. Serial No. 571,930.

To all whom it may concern:

Be it known that I, JOSEPH H. McBRIDE, a citizen of the United States, residing at Philadelphia, in the county of Philadelphia and State of Pennsylvania, have invented a certain new and useful Improvement in Coin-Controlled Apparatus, of which the following is a specification.

My invention relates to a new and useful improvement in coin controlled apparatus, and has for its object to construct a device which may be applied to telephone pay stations, vending machines and the like, whereby a spurious coin may be seen by a person standing in proximity to the machine, thus readily detecting any one using a worthless coin.

Another object of the invention is to provide for coin controlled apparatus a register which will keep a record of the number of coins entering the receptacle.

A further object of the invention is to provide a plunger having a coin slot formed in a portion thereof, a coin when in the slot operating the lock or dog, disengaging said dog from the plunger, allowing said plunger to operate which will turn the register, and at the same time ring a bell. As here shown the device consists essentially of a vertically sliding plunger having a coin slot, said plunger when unlocked operating suitable levers for turning the register, the end of said plunger coming in contact with a bell, thus notifying persons that the machine is being operated, and having suitable members for holding the last coin within the coin slot at a point where it may be readily seen.

With these ends in view, this invention consists in the details of construction and combination of elements hereinafter set forth and then specifically designated by the claims.

In order that those skilled in the art to which this invention appertains may understand how to make and use the same, I will describe its construction in detail, referring by letter to the accompanying drawing forming a part of this specification, in which—

Figure 1 is a longitudinal sectional view of an apparatus made in accordance with my improvement. Fig. 2, a plan view thereof, the cover being removed from the box containing the mechanism, and a portion of the register being broken away. Fig. 3,

a section at the line $x-x$ of Fig. 1. Fig. 4, a front elevation of the upper portion of the plunger showing the relation of the spring actuated dog thereto, and Fig. 5, a section at the line $y-y$ of Fig. 1.

In carrying out my invention as here embodied, A represents a casing divided into mechanism compartments B and coin compartments C by a partition D. Extending upward from this casing is the upright E, in which is formed the coin channel F, this channel being formed with parallel grooves G along both side walls, into which the coin snugly fits, it being understood that any number of these coin channels may be utilized, each having a plunger and operating mechanism as will be hereinafter described. The different channels may be made in different sizes to accommodate coins of different dimensions and denominations.

In the upright E beside the coin channel is vertically and slidably mounted the plunger H, having a coin slot I in the upper portion thereof, the entrance to said slot being at the top of the plunger, as at J, the exit from said slot being some distance below the end and within the upright E, as at K. In proximity to the exit of said slot is formed a projection L, which prevents backward movement of the coin when said coin engages the beveled nose M of the dog N said dog being held in engagement with the plunger by the spring O and adapted to engage with the notch P to lock the plunger when no coin is in the plunger. One edge of the plunger at its lower end is beveled as shown at Q, said beveled edge engaging one end of the swinging lever R, which is pivoted at S, the opposite end of said lever being pivoted at T to one end of the sliding finger U, the free end of said finger adapted to engage the teeth of the ratchet wheel V, journaled upon the partition D, and having in connection therewith a register disk W, said disk having numbers thereon to specify the number of coins in the coin receptacle or the amount of the coins therein. The ratchet wheel and register disk are held against backward movement by the spring Z, the free end of which rests upon the upper surface of the ratchet wheel producing sufficient friction to prevent any backward movement when the sliding finger U is disengaged from the teeth.

On the under side of the registering disk W is mounted a downwardly projecting pin

110.

or its equivalent which is adapted to successively engage the pins B' mounted upon the outer face of the disk C' which disk is at right angles to the disk W and journaled to the rear wall of the casing. This disk C' is turned one point each time the disk W makes one complete revolution, thus giving the total amount of coins in the receptacle.

The finger U is held out of engagement with the teeth of the ratchet wheel by the spring D', one end of which is attached to the casing, and the opposite end to the outer end of the lever R.

Upon the lower end of the plunger within the casing are mounted the arms E' and F'; these arms adapted to engage the pin G' mounted upon the holding member H' pivoted to the casing at I'; said holding member when in its normal or raised position lying across the coin channel F to hold the coin within the channel until the machine is again operated. On the rear face of the holding member H' is placed a projection J' which engages the bevel face K' of the member L', said member being hinged or pivoted at its upper end, as shown by M'; permitting the lower end to be forced outward by the spring N'. This member carries a pair of pins O' which project into the coin channel, holding the coin thereon while the preceding coin is being dropped to the coin receptacle.

The plunger H is normally held upward by the spring P', one end of which is fastened to the casing, and the opposite end to the plunger with each complete downward movement of the plunger, its lower end will come in contact with a bell Q', thus causing a signal to be sounded to notify the operator or other person that a coin has been placed in the device and said device operated.

In practice, a coin is placed in the coin slot I in the plunger H, said coin dropping to the lower end of the slot in proximity to the exit, then by pushing downward upon the plunger the coin will be brought into engagement with the nose of the dog N, riding over said dog and preventing it from coming in contact with the notch P, the projection L preventing any upward movement of the coin. After the coin has passed the dog N the coin will pass therefrom into the channel F and downward until it engages pins O', and since this channel is covered with a glass R' the coin may be readily seen by a person standing in proximity to the apparatus, and if the coin is a worthless one the user may be arrested. While this operation is taking place the arms E' engage the pin G' forcing the holding member H' downward, permitting the coin held thereby to pass into the coin receptacle C, at the same time the bevel edge Q of the plunger operates the lever R against the action of the spring D', causing the finger U to engage

one of the teeth of the ratchet teeth V, turning said ratchet wheel and the registering disk W, and when this registering disk has made one complete revolution the disk C' will be moved one point, at the same time the lower end of the plunger will ring the bell Q', thus sounding a signal to the operator or anyone within hearing distance. When the plunger is released the spring P' will draw the same upward releasing the end of the lever R so that the spring D' may bring it to its relaxed position. With this upward movement of the plunger the arm F' will engage the pin on the holder H', drawing said holder upward, causing the projection J' to engage the bevel face K' of the member L', forcing it against the action of the spring N' and withdrawing the pins O' from across the coin channel F, permitting the coin held thereby to drop downward to the holding member H', at which time the apparatus is ready to be again operated. Should anyone undertake to force the plunger downward without first placing a coin therein, the dog N will be forced into the notch P by the spring O, holding the plunger at this point and preventing the operation of the other parts.

Of course I do not wish to be limited to the exact details of construction here shown as these may be varied within the limits of the appended claims without departing from the spirit of my invention.

Having thus fully described my invention, what I claim as new and useful, is—

1. In a coin controlled apparatus, a casing, an upright leading therefrom, said upright being provided with a coin channel, a glass for covering said channel, a plunger having a coin slot in the upper end thereof and provided with a notch, and having its lower end beveled, said plunger being slidably mounted in the upright beside the coin channel, a spring actuated dog normally held in engagement with the edge of the plunger, a spring for normally holding the plunger upward, a ratchet wheel, a registering disk connected therewith, a sliding finger adapted to engage the teeth of said ratchet wheel, a pivoted lever, one end connected with the sliding finger, the opposite end engaging the beveled edge of the plunger, a spring for normally holding the finger out of engagement with the ratchet teeth, a pin projecting downward from the under side of the registering disk, a second registering disk mounted at right angles to the first named disk, pins carried thereby, the first named pin adapted to contact with said pins, and means for holding a coin in the coin channel.

2. In a coin controlled apparatus, a casing, an upright leading therefrom, said upright being provided with a coin channel, a glass for covering said channel, a plunger

having a coin slot in the upper end thereof and provided with a notch, and having its lower end beveled, said plunger being slidably mounted in the upright beside the coin channel, a spring actuated dog normally held in engagement with the edge of the plunger, a spring for normally holding the plunger upward, a ratchet wheel, a registering disk connected therewith, a sliding finger adapted to engage the teeth of said ratchet wheel, a pivoted lever, one end connected with the sliding finger, the opposite end engaging the beveled edge of the plunger, a spring for normally holding the finger out of engagement with the ratchet teeth, a pin projecting downward from the under side of the registering disk, a second registering disk mounted at right angles to the first named disk, pins carried thereby, the first named pin adapted to contact with said pins, a pivoted holding member having a forwardly projecting pin, arms mounted upon the plunger adapted to engage therewith, and means for holding a coin in the channel when the holding member is down.

3. In a coin controlled apparatus, a casing, an upright leading therefrom, said upright being provided with a coin channel, a glass for covering said channel, a plunger having a coin slot in the upper end thereof and provided with a notch, and having its lower end beveled, said plunger being slidably mounted in the upright beside the coin channel, a spring actuated dog normally held in engagement with the edge of the

plunger, a spring for normally holding the plunger upward, a ratchet wheel, a registering disk connected therewith, a sliding finger adapted to engage the teeth of said ratchet wheel, a pivoted lever, one end connected with the sliding finger, the opposite end engaging the beveled edge of the plunger, a spring for normally holding the finger out of engagement with the ratchet teeth, a pin projecting downward from the under side of the registering disk, a second registering disk mounted at right angles to the first named disk, pins carried thereby, the first named pin adapted to contact with said pins, a pivoted holding member disposed across the coin channel, a forwardly projecting pin mounted upon said holding member, two parallel arms spaced apart and secured to the plunger for engaging said pin to operate the holding member, a member having a beveled face hinged to the upright, pins carried thereby adapted to project into the coin channel, and a spring for normally causing said pins to enter the coin channel and the projection on the rear of the holding member adapted to engage the beveled face of the member L' to withdraw the pins.

In testimony whereof, I have hereunto affixed my signature in the presence of two subscribing witnesses.

JOSEPH H. McBRIDE.

Witnesses:

EDW. W. AUSTIN,
S. M. GALLAGHER.