

No. 664,448.

Patented Dec. 25, 1900.

F. M. TEEGUARDEN & J. B. HIMES.  
CORN HUSKER AND SHREDDER.

(Application filed Feb. 7, 1900.)

(No Model.)

3 Sheets—Sheet 1.

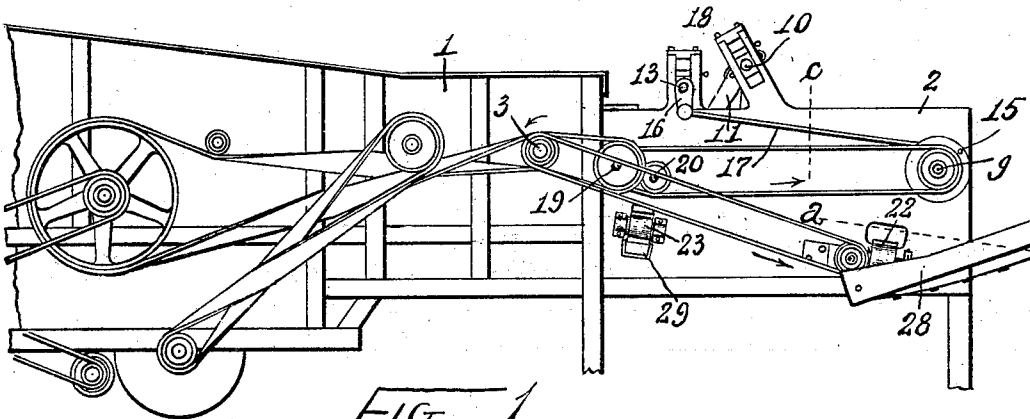

FIG. 1.

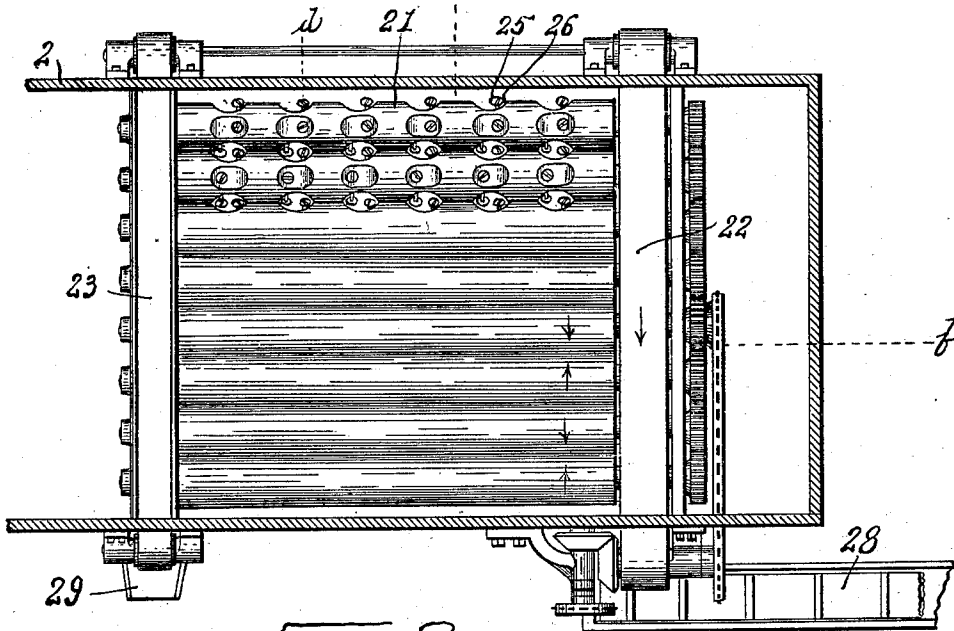

FIG. 2.

Freeman M. Teegarden  
Joseph B. Himes

Inventors

by James W. See

Attorney

Witnesses:  
E. R. Shipley  
M. S. Belden.

No. 664,448.

Patented Dec. 25, 1900.

F. M. TEEGUARDEN & J. B. HIMES.  
CORN HUSKER AND SHREDDER.

(No Model.)

(Application filed Feb. 7, 1900.)

3 Sheets—Sheet 2.

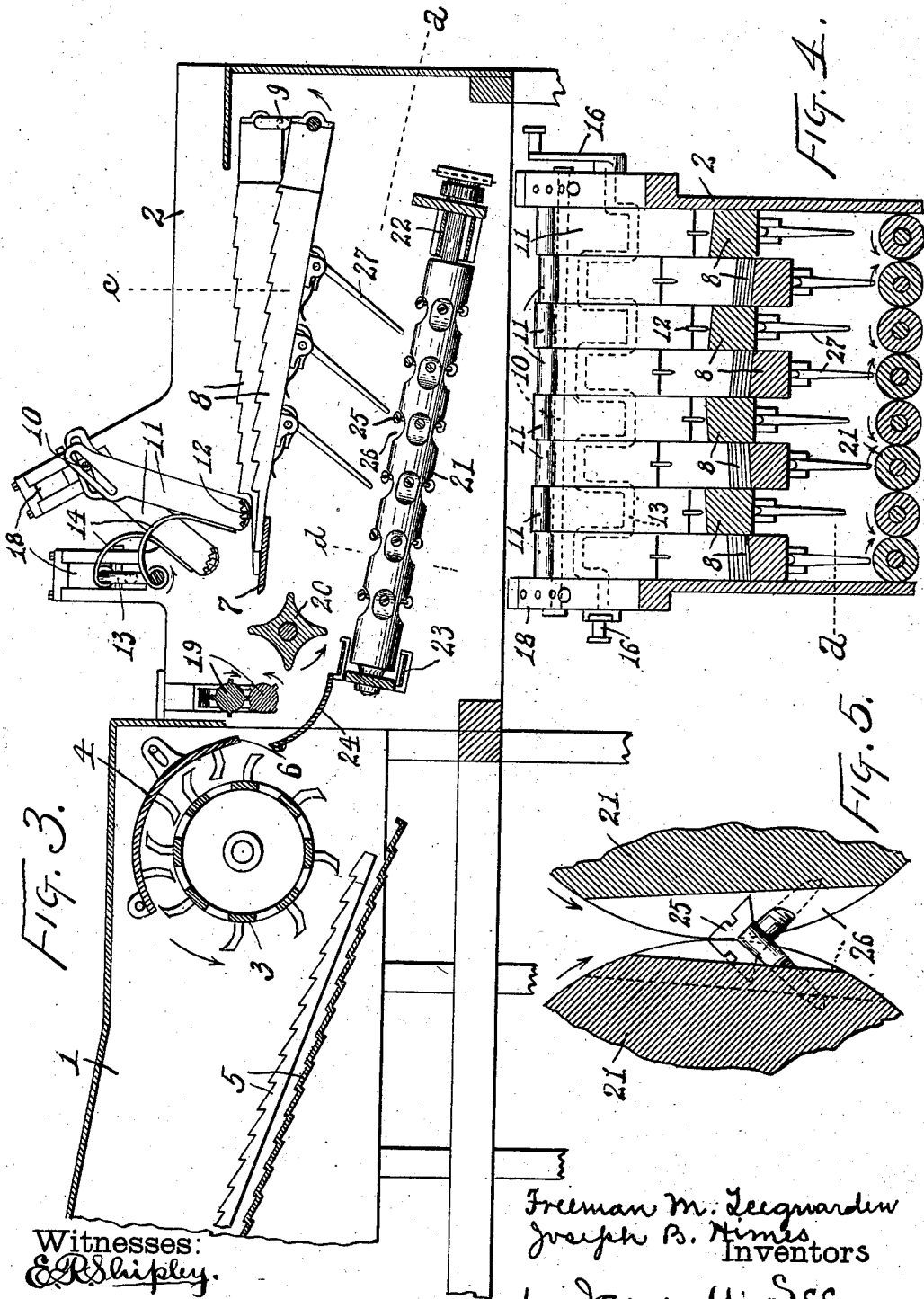

Witnesses:  
*E. R. Shipley.*  
*M. S. Belden.*

*Freeman M. Teegarden*  
*Joseph B. Himes*  
Inventors  
by *James W. Sec*  
Attorney

F. M. TEEGUARDEN & J. B. HIMES.  
CORN HUSKER AND SHREDDER.

(No Model.)

(Application filed Feb. 7, 1900.)

3 Sheets—Sheet 3.

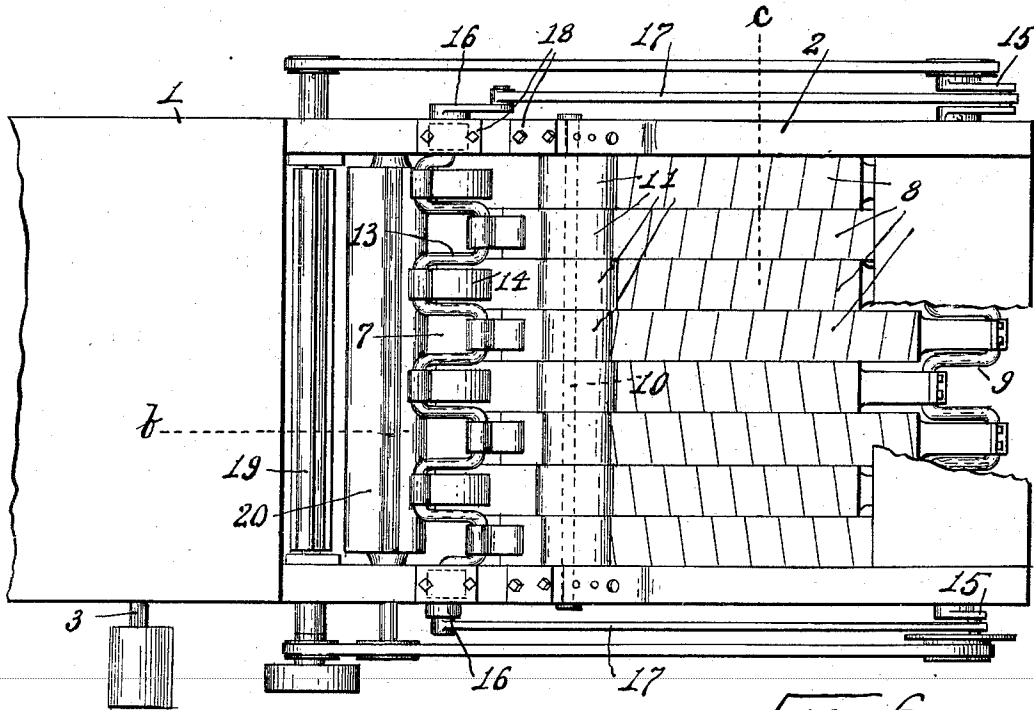

FIG. 6.

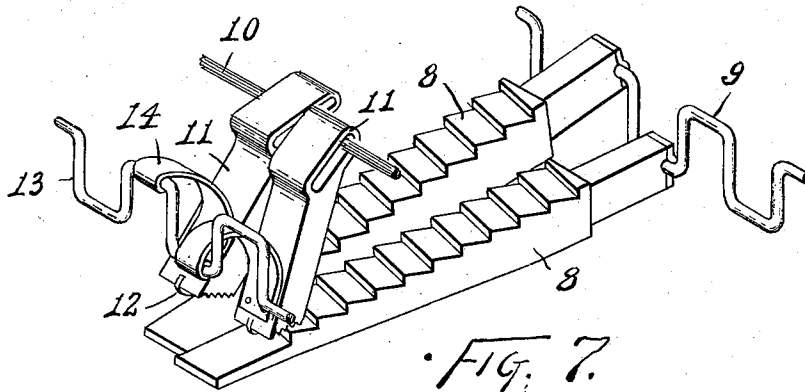

FIG. 7.

Freeman M. Teegarden  
 Joseph B. Himes  
 Inventors  
 by James W. See  
 Attorney

Witnesses:  
*E. Shipley*  
*M. Belden*

# UNITED STATES PATENT OFFICE.

FREEMAN M. TEEGUARDEN AND JOSEPH B. HIMES, OF NEW CASTLE, INDIANA, ASSIGNORS, BY MESNE ASSIGNMENTS, TO SAID TEEGUARDEN AND HIMES AND T. H. GORDON, GEORGE GORDON, AND THOMAS L. CAMPBELL, OF SAME PLACE.

## CORN HUSKER AND SHREDDER.

SPECIFICATION forming part of Letters Patent No. 664,448, dated December 25, 1900.

Application filed February 7, 1900. Serial No. 4,332. (No model.)

*To all whom it may concern:*

Be it known that we, FREEMAN M. TEEGUARDEN and JOSEPH B. HIMES, citizens of the United States, residing at New Castle, Henry county, Indiana, (post-office address, New Castle, Indiana,) have invented certain new and useful Improvements in Corn Huskers and Shredders, of which the following is a specification.

10 This invention pertaining to improvements in machines adapted for the husking and shredding of corn will be readily understood from the following description, taken in connection with the accompanying drawings, in  
15 which—

Figure 1 is a side elevation of the feed-end portion of a machine exemplifying our present invention; Fig. 2, a horizontal section of the same in the plane of line *a*; Fig. 3, a vertical longitudinal section in the plane of line  
20 *b*; Fig. 4, a vertical transverse section in the plane of line *c*; Fig. 5, a vertical transverse section of portions of a pair of husking-rolls in the plane of line *d*; Fig. 6, a plan of the  
25 devices illustrated in Fig. 3, and Fig. 7 a perspective view of a pair of the wriggle-bars and wriggle-feet with their operating-cranks.

In the drawings, giving particular attention to Fig. 3, 1 indicates the usual framing, &c.,  
30 at the feed-end portion of a husking and shredding machine; 2, the outer prolongation of the same for the support of the feeding and husking mechanism; 3, the beating-cylinder, of usual form and disposition and provided with the usual teeth, the rake of the  
35 teeth, however, and the direction of motion of the cylinder being such that the upper portion of the cylinder runs from the feeding end of the machine—that is to say, material fed  
40 in to the beating-cylinder passes over instead of under the cylinder; 4, the usual concave provided with teeth cooperating with the beating-cylinder, this concave, however, being located over the cylinder and having the rake  
45 of its teeth appropriate to the above-stated direction of motion of the beating-cylinder; 5, the usual vibrating fodder-conveyers leading from the cylinder of the machine rear-

wardly toward the discharge end of the machine; 6, the front extremity of the concave, 50 the same being a trifle above the horizontal plane of the axis of the cylinder and at the front of the cylinder, the term "front" as herein used having reference to the feeding or receiving end of the machine; 7, a horizontal 55 table-bar extending across the framing some distance in front of breaking edge 6 of the concave and by preference a trifle below the level of breaking edge 6; 8, a series of wriggle-bars lying side by side and 60 having their inner ends resting on table-bar 7, these wriggle-bars being capable of an end-wise-reciprocating motion and their front ends being capable of rising-and-falling motion, the upper surfaces of these wriggle-bars 65 being provided with ratchet-shaped teeth presenting their vertical faces toward the cylinder and concave, the upper surfaces of these bars being arranged at an outward transverse decline, as seen in Fig. 4, and the vertical 70 faces of the ratchet-teeth inclining outwardly and rearwardly, as seen in Fig. 6; 9, a multiple crank-shaft journaled in the framing at the front ends of the wriggle-bars, contiguous cranks of this shaft being set opposite each 75 other and each crank being engaged by a wriggle-bar, so that as the shaft is rotated the alternate wriggle-bars will have their front or right-hand ends elevated and the bars be moved toward the cylinder and concave, while the intermediate wriggle-bars will 80 descend and move away from the cylinder and concave; 10, a rod disposed across the framing some distance above the inner ends of the wriggle-bars; 11, a series of wriggle- 85 feet disposed side by side and mounted on rod 10, the feet being provided with diagonal slots engaging the rod, the toes of the feet being transversely corrugated, and there being one of these feet for and over each of the wriggle-bars; 12, a band-cutting knife 90 disposed fore and aft in the sole of each of the wriggle-feet, these knives having their lower edges forming the arc of a circle and by preference provided with bearded or sickle 95 edges; 13, a multiple crank-shaft disposed

across the framing to the rear of the wriggle-feet and having its contiguous cranks set opposite each other, there being one crank for each of the wriggle-feet, this multiple crank-shaft turning in unison with multiple crank-shaft 9, which operates the wriggle-bars; 14, spring connections between wriggle-feet 11 and the appropriate cranks of shaft 13; 15, Fig. 6, a crank on each outer end of multiple crank-shaft 9, these two cranks being set in quartering relationship to each other; 16, a crank on each outer end of multiple crank-shaft 13, these two cranks being set in quartering relationship to each other, cranks 16 and 15 having equal stroke; 17, connecting-rods, one at each side of the machine, connecting cranks 15 and 16, whereby rotary motion imparted to one of the multiple crank-shafts results in rotary motion being transmitted in unison to the other of the multiple crank-shafts; 18, slotted housings carried by the framing to support rod 10 and crank-shaft 13 and permit of their adjustment at various heights above the wriggle-bars, the adjustment being effected by pinning the supporting-boxes of the rod and shaft higher or lower in the slots of the housings; 19, a pair of horizontal snapping-rolls journaled in the framing in front of breaking edge 6 of the concave, one roll being over the other and the space between the two rolls being at or a trifle below the level of breaking edge 6 of the concave, these snapping-rolls being cylindrical, but being provided each with four longitudinally-extending ribs margining extended plain peripheral surfaces of the rolls and the acting rib of one roll coming between the ribs of the other roll, these snapping-rolls being spring-mounted in the usual manner; 20, a roll of star section mounted horizontally in the framing in the space between snapping-rolls 19 and table-bar 7, the upper portion of this star-shaped roll turning toward the snapping-rolls and projecting a trifle above the level of table-bar 7; 21, the usual transverse series of husking-rolls arranged, as usual, at an inclination, with their receiving ends below the snapping-rolls, these husking-rolls being arranged, as usual, to run together in pairs, with contiguous surfaces of the rolls of a pair running downwardly, the actuating-gearing being of the usual character; 22, (see also Fig. 2,) ear-corn-conveying belt extending across the lower ends of the husking-rolls and adapted, as usual, to receive from those rolls the husked ears of corn and to convey them outside the casing of the machine; 23, (see also Fig. 2,) a shelled-corn-conveying belt extending across the higher ends of the husking-rolls and serving to gather shelled corn falling from the snapping-rolls and prevent it from going to the husking-rolls and to convey it outside the casing of the machine; 24, a gutter disposed across the framing below snapping-rolls 19 and arranged at a transverse inclination and being so disposed that its lower edge will discharge

to conveyer-belt 23; 25, (see also Fig. 5,) husking-pins projecting, as usual, from the surface of the husking-rolls, these pins in the present case, however, being so disposed in the rolls and the motion of the rolls being so timed that the downwardly-running pins of contiguous rolls come opposite each other, clearing each other sidewise to permit the pins to pass; 26, the usual recesses in the husking-rolls to permit of the passage of the pins of the contiguous rolls; 27, a series of feed-fingers projecting downwardly from each of the wriggle-bars 8 toward and near to the husking-rolls, these feed-fingers projecting diagonally toward the higher ends of the husking-rolls and the heels of the fingers being flexibly coupled to the wriggle-bars, so that the fingers are capable of elastically yielding upwardly and rearwardly; 28, Fig. 2, the usual ear-corn elevator receiving the ears of corn from conveyer-belt 20 and serving to take it to the ear-pile or receiving-wagon, and 29, Fig. 2, discharge-spout of shelled-corn conveyer 23, the same being adapted to discharge the shelled corn to a vessel or elevator or other receiving agent.

The exemplifying system of gearing for transmitting motion to the parts will be obvious from the drawings and will call for no description.

The series of wriggle-bars 8 constitute a four-motion feed-table. The set of alternate bars and the set of intermediate bars move forward toward the cylinder and concave in alternation. Each set of bars moves to the right under the stalks or grain, which is placed over the wriggle-bars, then descends and rises and moves toward the cylinder and concave, the ratchet form of teeth with which the wriggle-bars are provided tending in an obvious manner to produce a feeding motion of the material toward the cylinder and concave. The outward transverse slope of the tops of the wriggle-bars gives a general crowning effect to the feeding-table, produced by the wriggle-bars, and tends to even and distribute the material thrown upon the wriggle-bars.

The wriggle-feet 11 have a four-motion step-like action, each foot working in unison with the wriggle-bar directly below it, a given wriggle-bar ascending, then retreating, then descending upon the stalks, which become caught between the feet and the wriggle-bar, the foot and the wriggle-bar then moving toward the cylinder and concave and forcing the stalks along, the wriggle-foot then rising and releasing the grip upon the stalks, the wriggle-feet and wriggle-bar returning for a new grip, and so on. The elastic connections 14 between the wriggle-feet and the cranks of shaft 13, which actuate them, endow the feeding system with a capacity for gripping the stalks elastically and properly yielding to accommodate irregularities in quantity being gripped. By adjusting shaft 13 and rod 10 up and down in the slots of housings 18

the normal distance between the soles of the wriggle-feet and the tops of the wriggle-bars may be adjusted, thus providing for an adjustment of the general quantity of material to be fed. The corrugations in the soles of the wriggle-feet increase the gripping capacity of the feet, and the knives 12, with which the feet are provided, serve in cutting the bands of bundles fed by the mechanism.

10 Stalks fed by the feeding mechanism pass under the breaking edge 6 of the concave and are bent upward by the action of the cylinder-teeth and given a preliminary breaking at frequent intervals as they pass breaking  
15 edge 6.

Corn fed by the feeding mechanism enters the throat of snapping-rolls 19 and is by them carried forward to the cylinder and concave, the ribs of the snapping-rolls, however, snapping off the ears, which fall down in front of the snapping-rolls. The peculiar cross-section of the snapping-rolls, comprising extended peripheral surfaces and prominent ribs, increases the effectiveness of the snapping-rolls and results in the shelling of less corn than usual from the ears.

There must necessarily be some space between table-bar 7 and the snapping-rolls in order that the detached ears may fall down to the husking-rolls below. Much in the way of leaves, loose husks, and fine stalk parts tend to descend through the space in question, when it is desirable that they go onward to be shredded by the cylinder. Star-shaped  
35 roll 20 in the space in question serves in beating upward upon and carrying onward the material just referred to, while not interfering with the falling of the detached ears of corn. This star-shaped roll 20 also serves as  
40 a clearing device for the upper ends of the husking-rolls, it serving to dislodge and start forward any accumulation of ears or other material upon the heads of the husking-rolls.

The detached ears of corn fall from the snapping-rolls to the head of the husking-rolls and are husked by the latter, as usual, the husked ear-corn passing away by conveyer-belt 20.

More or less corn will necessarily be shelled by the snapping-rolls. This corn instead of falling to the husking-rolls with the ears is caught by gutter 24 and delivered to conveyer-belt 23, which carries it away.

The peculiar arrangement of the pins in the husking-rolls results in superior action. Heretofore a pin projecting from a roll has cooperated merely with a clearance-recess in the opposing roll, the pins being so disposed in the rolls and the motion of the rolls being so timed that a pin of one roll alternated in action with the pin of the mating roll. In the present arrangement the pins are so disposed in the rolls and the motion of the rolls is so timed that pins of the pair of mating  
65 rolls come opposite each other and coact with each other in gripping the husks and removing them from the ears of corn.

Fingers 27 reciprocate with the wriggle-bars which carry them and serve to accelerate the traveling motion of the ears of corn  
70 down the incline of the husking-rolls. In case these fingers meet with extraordinary heavy duty their flexible mounting on the wriggle-bars permits of their yielding.

We claim as our invention—

75 1. In a corn husker and shredder, the combination, substantially as set forth, of a toothed beating-cylinder, a toothed concave, a pair of snapping-rolls disposed in front of said cylinder, a series of husking-rolls with  
80 their heads below the snapping-rolls and adapted to receive ears of corn falling therefrom, and a conveyer disposed across the heads of the husking-rolls and under the snapping-rolls and adapted to catch shelled  
85 corn falling from the snapping-rolls and convey the same away free of the husking-rolls.

2. In a corn husker and shredder, the combination, substantially as set forth, of a toothed beating-cylinder, a toothed concave,  
90 a pair of snapping-rolls disposed in front of the cylinder, a feed-table in front of but a distance from the snapping-rolls, a transversely-inclined gutter below the snapping-rolls, a conveyer-belt below the lower edge of  
95 said gutter, a series of husking-rolls with their heads disposed below the upper member of said conveyer-belt, and a roller of star-shaped section disposed in the space between the feed-table and the snapping-rolls and  
100 over said conveyer-belt.

3. In a corn husker and shredder, the combination, substantially as set forth, of a toothed beating-cylinder, a toothed concave, a feed-table disposed in front of said cylinder,  
105 a series of wriggle-feet with rigid soles presented toward said feed-table, a supporting-rod engaging slots in the upper portion of said wriggle-feet, a shaft provided with a crank for each of said wriggle-feet and having its  
110 contiguous cranks oppositely set, connections between said cranks and wriggle-feet, and springs interposed in said connections, one between each wriggle-foot and its crank.

4. In a corn husker and shredder, the combination, substantially as set forth, of a toothed beating-cylinder, a toothed concave, a pair of snapping-rolls in front of the cylinder, a series of husking-rolls with their heads  
120 disposed below said snapping-rolls, and husking-pins projecting from recesses in said husking-rolls, said pins being so positioned in the rolls, and the motions of the rolls being so timed that as a given pair of mating rolls move their contiguous surfaces downwardly  
125 a husking-pin of one of the rolls will meet and pass a husking-pin in a recess of the mating roll.

5. In a corn husker and shredder, the combination, substantially as set forth, of a  
130 toothed beating-cylinder, a toothed concave, a pair of snapping-rolls disposed in front of the cylinder, a series of husking-rolls disposed with their axes at right angles to the axes of

the snapping-rolls and below said snapping-rolls, a feed-table disposed over the husking-rolls and in front of the snapping-rolls and formed of a series of reciprocating wriggle-bars, and a series of feed-fingers projecting diagonally downwardly from each of the wriggle-bars toward and near to the husking-rolls and having their heels flexibly coupled to the wriggle-bars so that the fingers are capable of elastically yielding upwardly and rearwardly.

6. In a corn husker and shredder, the combination, substantially as set forth, of a toothed beating-cylinder, a toothed concave, a pair of snapping-rolls disposed in front of the cylinder, a feed-table disposed in front of said snapping-rolls and formed of a series of reciprocating wriggle-bars, and ratchet-shaped teeth in the upper surfaces of said wriggle-bars, the upper surfaces of said teeth declining outwardly from the transverse center of the series of wriggle-bars.

7. In a corn husker and shredder, the combination, substantially as set forth, of a toothed beating-cylinder, a toothed concave, a pair of snapping-rolls disposed in front of the cylinder, a feed-table disposed in front of said snapping-rolls and formed of a series of reciprocating wriggle-bars, and ratchet-shaped teeth in the upper surface of said wriggle-bars, the upper surfaces of said teeth declining outwardly from the transverse center of the series of wriggle-bars and the vertical faces of said teeth being disposed at an angle transverse to the bars so that the faces of the teeth at the inner edges of the bars are closer to said cylinder than the faces of the teeth at the outer edges of the bars.

FREEMAN M. TEEGUARDEN.  
JOSEPH B. HIMES.

Witnesses:

ROBT. N. CAMPBELL,  
HARRY H. STRETCH.