

J. C. ST. CLAIR.
 AUTOMATIC FIRE KINDLER.
 APPLICATION FILED MAR. 16, 1907.

919,085.

Patented Apr. 20, 1909.

2 SHEETS—SHEET 1.

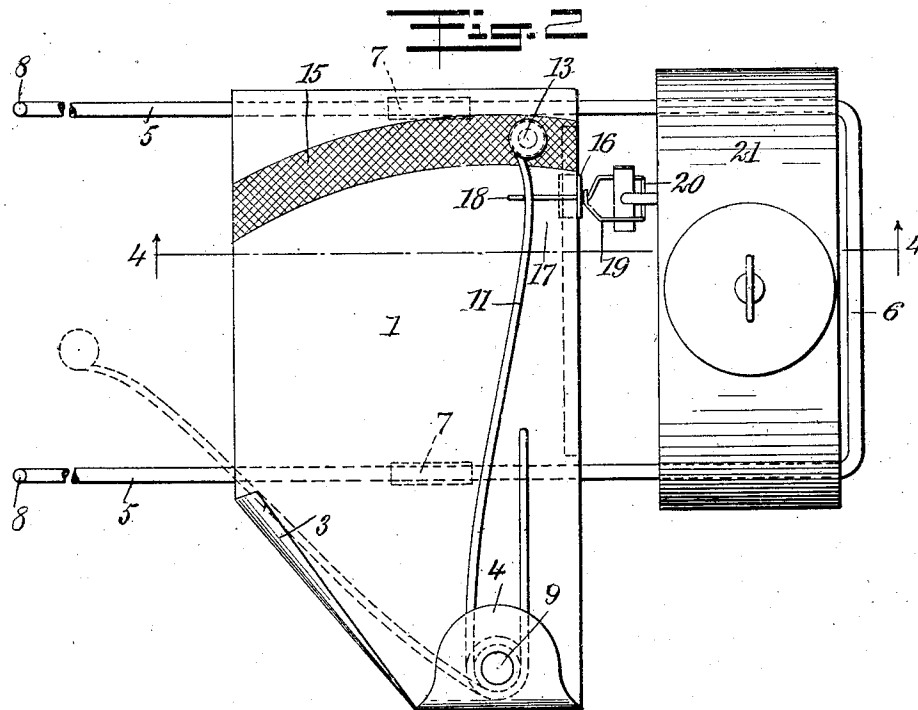
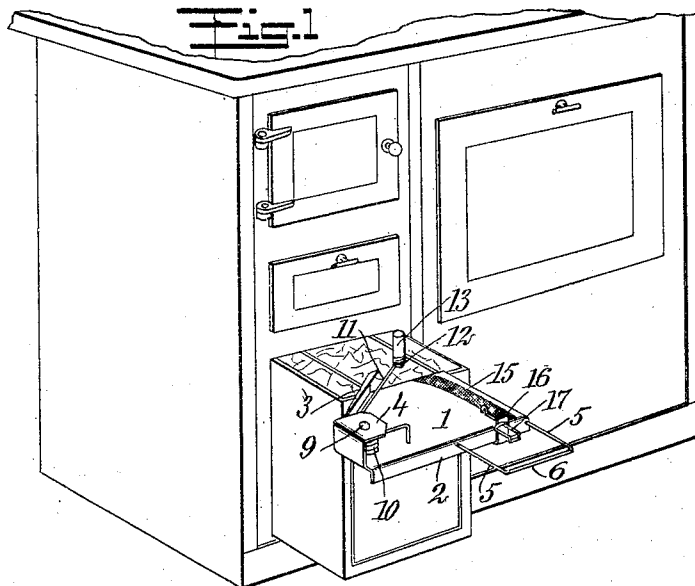

WITNESSES

F. D. Sweet.
W. W. A. Co.

INVENTOR

John Christian St. Clair

BY *Munroe*

ATTORNEYS

919,085.

J. C. ST. CLAIR.
AUTOMATIC FIRE KINDLER.
APPLICATION FILED MAR. 15, 1907.

Patented Apr. 20, 1909.

2 SHEETS—SHEET 2.

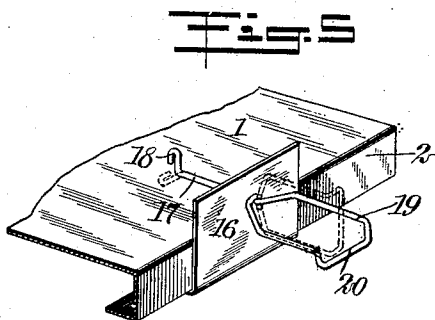
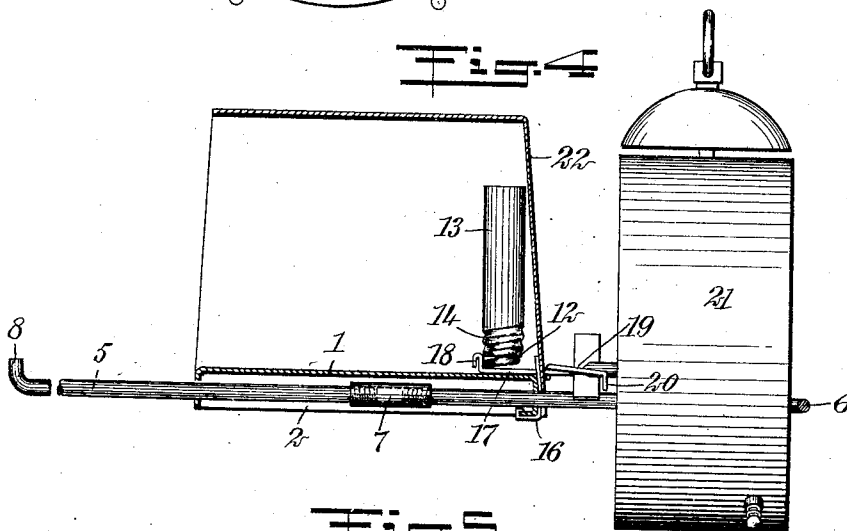
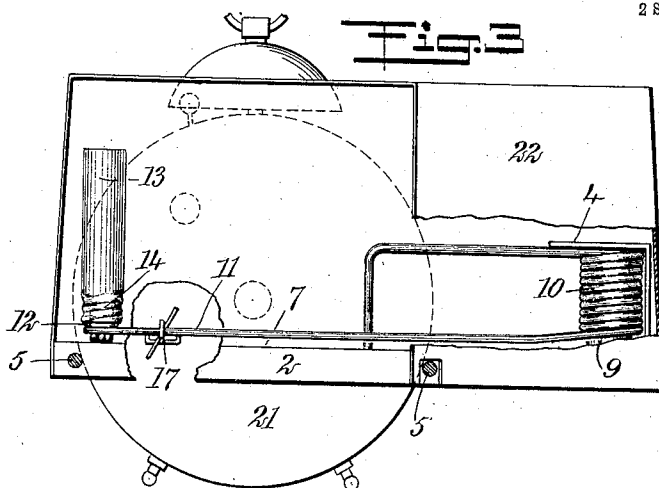

WITNESSES
F. D. Sweet
W. W. Hobb

INVENTOR
John Christian St. Clair
BY *Mum & Co*
ATTORNEYS

UNITED STATES PATENT OFFICE.

JOHN C. ST. CLAIR, OF BUTTE, MONTANA.

AUTOMATIC FIRE-KINDLER.

No. 919,085.

Specification of Letters Patent.

Patented April 20, 1909.

Application filed March 15, 1907. Serial No. 362,472.

To all whom it may concern:

Be it known that I, JOHN C. ST. CLAIR, a citizen of the United States, and a resident of Butte, in the county of Silverbow and State of Montana, have invented a new and Improved Automatic Fire-Kindler, of which the following is a full, clear, and exact description.

The invention has in view the provision of a kindler adapted to automatically operate at any predetermined time to start a fire.

As shown and hereinafter described, the invention is more especially designed for cooking ranges. It will, however, be apparent that the kindler can be applied to other types of stoves, as well as to open fire-places and operate with equal effectiveness.

Reference is to be had to the accompanying drawings forming a part of this specification, in which similar characters of reference indicate corresponding parts in all the figures.

Figure 1 is a fragmentary view of a cooking range with my improvements applied thereto; Fig. 2 is a plan of the kindler showing the same as set in full lines and when released in dotted lines; Fig. 3 is a rear side elevation partly broken away to show the interior construction; Fig. 4 is a longitudinal section substantially on the line 4—4 of Fig. 2, looking in the direction of the arrows, and Fig. 5 is a fragmentary, perspective view of the base plate and the trigger for releasing the kindling mechanism supported thereby.

The preferred construction of my improved kindler comprises a base plate 1 of sheet metal having downwardly-turned flanges 2 at the front, rear and at one side, and with a curled-over corner 3 and a tongue 4 bent upon the plate at the opposite side. Passing through the front and rear flanges of the base plate are rods 5 joined together at their forward ends by a crossbar 6, the rear ends of each of said rods being detachably connected by threaded couplings 7, which are arranged underneath the plate 1. As shown in Figs. 2 and 4, the rear extremities of the rods 5 are upwardly-turned, as indicated at 8, which serve as hooks for engaging underneath the grate-bar of the stove and thus support the releasing and striking mechanism.

Surrounding a pin 9 fixed between the plate and tongue 4, is a coiled spring 10, one end of which is fixed to the plate 1 by passing it through an opening therein, as indicated in Fig. 1, and the opposite end

being extended to form an arm 11, the outer free end of which is coiled upwardly to provide a tubular holder 12. Fitting over the holder 12 is a cap 13 having screw-threads 14 pressed into its lower end and providing a screw-threaded engagement with the convolutions of the holder. The tension of the spring 10 is such as to normally tend to force the arm 11 in the direction of the plate 1, as also in the direction of the corner 3, the latter providing a stop therefor.

The plate 1, as shown in Figs. 1 and 2, is roughened as indicated at 15, in the path of the holder 12 in order that when matches are placed within said holder and the screw cap 13 properly adjusted to bring them to the face of said plate, they will be ignited in the travel of the arm from its position shown in full lines in Fig. 2 to the position shown in dotted outline in this figure.

As best shown in Figs. 4 and 5, a portion of the lower edge of the flange 2 is inwardly turned and slidably embraced by the lower angular end of a plate 16 forming a support for a trigger 17 which passes through it. This sliding engagement of the plate permits its lateral adjustment to accommodate the trigger to clocks having their winding stems variously located. The trigger 17 is preferably constructed of wire with an inner hooked end 18 at the inner side of the plate 16 and a loop 19 at the opposite and outer side, the latter being bent substantially at right angles, as indicated at 20.

In the use of the kindler, an ordinary alarm or other form of clock 21 is seated on the rods 5 adjacent to the crossbar 6 after the alarm mechanism of the clock has been wound and set to be released at the time desired to start the fire, the ash-box of the stove at this time being slightly withdrawn and containing inflammable matter, such as paper. The arm 11 is then drawn against the tension of the spring 10 and engaged with the hooked end of the trigger, as shown in Fig. 4, the looped end of said trigger being passed over the winding stem of the alarm in such a manner that the trigger will be caused to turn therewith when the alarm is released. The operation of setting the kindler is then completed on placing one or more matches within the holder 12 and properly adjusting the cap 13 to bring the heads of the matches in contact with the roughened portion of the plate 1. When the time for starting the fire is now reached, the arm 11 is released,

which, under the influence of the spring 10, strikes the matches in its travel against the roughened portion 15 and drops them into the inflammable material placed within the ash-pan, the arm being brought to a stop in the manner aforesaid.

In order that the sparks from the matches as they are ignited, may be prevented from falling into the room, a hood 22 is so shaped as to neatly fit and inclose the plate 1 and attached mechanism except that portion adjacent to the ash-pan. This hood is easily removed and replaced after the kindler has been set.

Although I have described the construction in detail, I, nevertheless, regard the precise embodiment as not material provided the essential characteristics are employed as pointed out in the annexed claims.

Having thus described my invention I claim as new and desire to secure by Letters Patent:

1. A fire-kindler comprising a spring arm having the free end thereof coiled to form a match-holder, and a cap passing over said coil.

2. A fire-kindler comprising a spring arm having the free end thereof coiled to form a match-holder, and a cap threaded on the convolutions of said coil.

3. A fire-kindler comprising a base-plate, a spring arm having a match-holder operating over said plate, means for holding said arm against the tension of the spring, a stop

for limiting the movement of said arm when released, and rods on which the base-plate is slidably supported.

4. A fire-kindler comprising a coiled match-holder, and a cap threaded on the convolutions of said coil.

5. A fire-kindler comprising a base, a spring arm having a match-holder movably mounted over the base, and a revoluble trigger adjustable transversely on the base adapted to hold said arm under the tension of its spring.

6. A fire-kindler comprising a base plate, a spring arm having a match-holder movable over said plate, a stop for limiting the movement of said arm formed by bending an edge of the plate upwardly into the path thereof, and a revoluble trigger carried by said base plate for retaining said arm under the tension of its spring.

7. A fire kindler comprising a base, a spring arm having a match holder movable over said base, and an axially revoluble trigger carried by the base adapted to hold said arm under the tension of the spring, and having a loop for detachably connecting it with a releasing mechanism.

In testimony whereof I have signed my name to this specification in the presence of two subscribing witnesses.

JOHN C. ST. CLAIR.

Witnesses:

F. D. CHANDLER,
W. E. MUNROE.