

No. 831,739.

PATENTED SEPT. 25, 1906.

A. L. NOONE.
PRESSURE REGULATOR.
APPLICATION FILED MAR. 22, 1905.

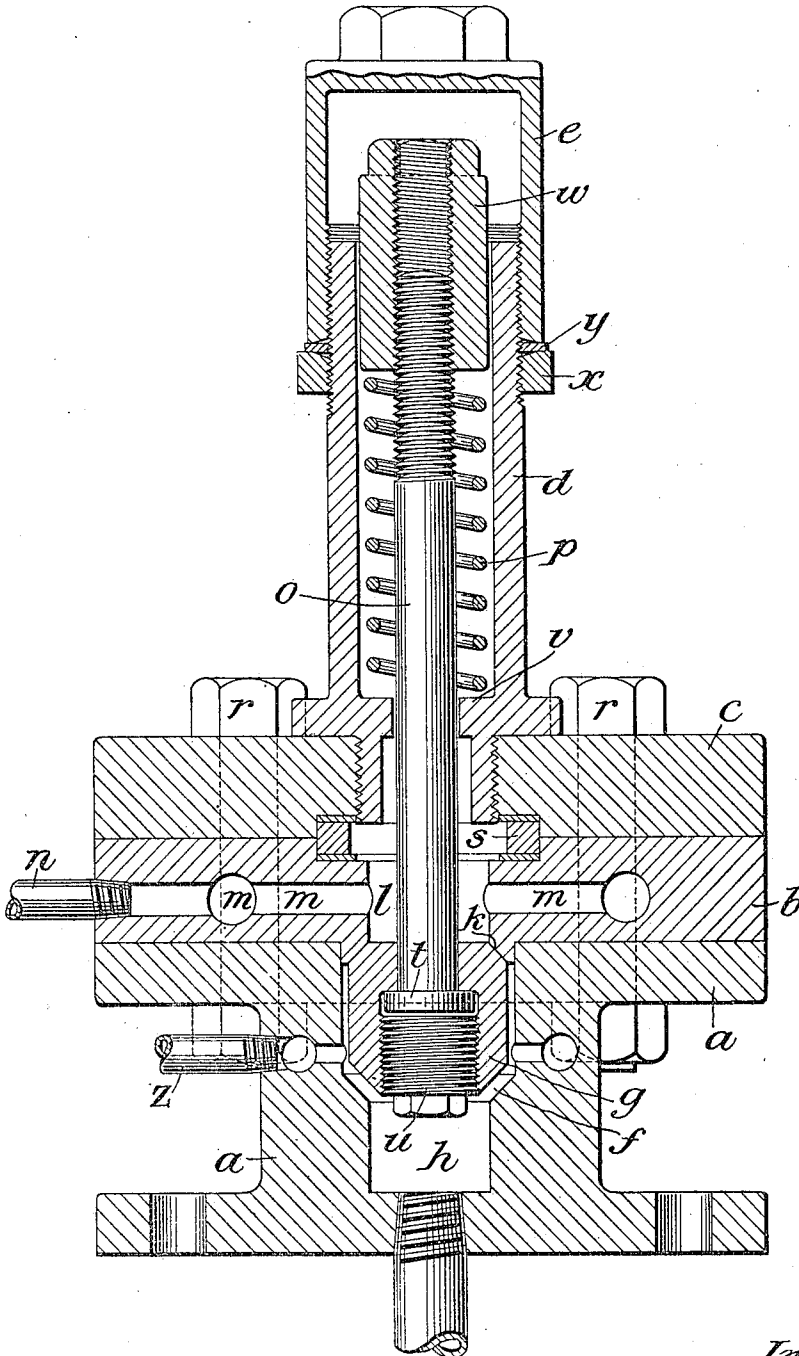

Witnesses

Chas. D. King.
A. H. Jesbera.

Inventor:

Anthony L. Noone
by Redding Kiddle Greeley
Attys.

UNITED STATES PATENT OFFICE.

ANTHONY L. NOONE, OF NEW YORK, N. Y.

PRESSURE-REGULATOR.

No. 831,739.

Specification of Letters Patent.

Patented Sept. 25, 1906.

Application filed March 22, 1905. Serial No. 251,409.

To all whom it may concern:

Be it known that I, ANTHONY L. NOONE, a citizen of the United States, and a resident of the borough of Brooklyn, of the city of New York, in the State of New York, have invented certain new and useful Improvements in Pressure-Regulators, of which the following is a specification, reference being had to the accompanying drawing, forming a part hereof.

The object of this invention is to provide a simple device for regulating with great accuracy the pressure of gas transmitted through it, whereby gas under reduced pressure may be supplied to any system from a source of gas-supply. Devices of this sort in use heretofore have generally been complicated structures and have not possessed all the sensitiveness that could be desired, and on this account they have not been entirely successful in keeping up a constant pressure of the desired degree in the system in which they have been employed.

In accordance with the present improvements one regulating-valve is employed, which is arranged loosely between its inclosing walls, so as to prevent, as far as possible, all friction in the operation thereof. This valve coöperates with two valve-seats, which are provided at either end thereof, and said valve is also provided with a valve-stem, which is held loosely in said valve, whereby the moving out of true of the stem does not throw the valve out of center, but permits it at all times to seat itself squarely.

The improvements will be more fully described with reference to the accompanying drawing, in which a regulator embodying the invention is shown in central vertical section.

In the present embodiment of the invention the regulator is made up of four castings *a*, *b*, *c*, and *d*, respectively, the last being provided with a cap *e*; but the precise construction illustrated in the drawing is not an essential, as will be obvious from the description as it proceeds.

The casting *a*, which may be formed so as to be readily attached to a part of the apparatus with which it is used, is also formed with the valve-seat *f* for the valve-plug *g*.

Said casting is also hollowed to form a relatively small chamber or space *h* at one end of the valve-plug for the return-gas, as will be explained hereinafter, and said space broadens out above the valve-seat *f*, thereby providing a place for the valve-plug to reciprocate in, the area of which is sufficient to form a space around the valve-plug. In this space around the valve-plug the gas is adapted to circulate, and from said space it is discharged into the system in which the regulator is employed through a suitable discharge-pipe, (indicated at *z*,) said discharge-pipe being located between the upper and lower ends of the valve. The other end of the valve—that is, the upper end—coöperates with the valve-seat *k*, formed in the casting *b*, which casting is hollowed to form a central space *l* at that end of the valve and spaces *m* of any suitable design for the reception of the gas from a source of supply, (indicated at *n*.) The valve-seat *k* preferably forms a circular flange upon the casting *b*, which flange enters the hollow space in the casting *a*, thereby forming a tight joint between these two castings, as well as forming the upper valve-seat. The casting *c*, which is also hollowed centrally to permit the valve-stem *o* to extend therethrough, has threaded in this central space the casting *d*, which is provided for the upper part of the valve-stem and for the regulating-spring *p*. The castings *a*, *b*, and *c* are secured together in any suitable way, as by bolts *r*, and a suitable packing *s* is provided between the castings *b* and *c* in order to secure a tight joint therebetween.

The valve-stem *o* is loosely secured to the valve-plug, and for this purpose it is provided with a head *t*, the stem being inserted through an opening in the top of the valve-plug and held therein with a certain amount of play by a nut *u*, threaded in the bottom of the valve-plug. The upper end of the stem has a regulating-nut *w* threaded thereon, by means of which the regulating-spring *p*, which is held between said nut and a flange *v* in the casting *d*, may be extended or compressed to regulate the tension thereof. The nut *w* and the casting *d* are of such dimensions as to form a free annular space between the nut and the walls of said casting,

whereby the space above the nut and around the stem is at all times in communication with the space *l*.

The cap *e* is threaded upon the end of the casting *d*, a jam-nut *x* being provided to tighten the same thereon, and a washer or other suitable packing-ring *y* may be provided between the cap *e* and the jam-nut *x* in order to prevent the gas from leaking out around the edges of the cap.

The operation of the device is as follows: The gas enters from a suitable source of supply and fills the space *l* and the space *m* and also the space surrounding the entire stem of the valve, such gas being at the pressure of the supply-gas, which may be at a very high pressure in some cases, such as in the case of steam or of carbonic-acid gas, or may exist at a moderate pressure, as in other cases. This gas acts upon the top of the valve-plug, tending to force it downward against the action of the regulating-spring, which has been set for a given pressure. The regulating-spring, as is obvious, tends to hold the valve upon its seat *k*; but as the pressure from the main source fills the chamber *l* it causes the valve-plug to be depressed against the action of the spring unless the tension of the spring is greater than the force of the gas acting upon the top of the valve. Inasmuch as the gas surrounds the entire valve-stem, it is clear that the pressure of the gas upon the top of the valve will always be proportional to the pressure of the main supply and to the total area of the top of the valve. As soon as the valve is depressed the gas will flow down around the valve and into the discharge-pipe *z*, which leads to the system to be supplied. The depression of the valve will cause it to seat itself upon the lower valve-seat *f*, whereby it will be subject to any pressure which may exist in the lower space or chamber *h*. This chamber is made to communicate with the system which is supplied from the discharge-pipe *z*, and said chamber preferably communicates with the system near the point of application of the gas-pressure and will therefore receive gas from the system at substantially the same pressure at which it exists in the system. There will therefore be an upward pressure exerted upon the valve by the return-gas in the space *h*, and this upward pressure will act over the entire area of the valve and will therefore be substantially proportional to the total area of the valve and the pressure of the gas in the space *h*. This pressure, as is obvious, will act with the spring and when sufficiently great will cause the valve to rise again, thus diminishing the supply of gas to the system or cutting it off entirely. In case the pressure of the gas which is received from the

source of supply be sufficient to exert a pressure of one hundred pounds upon the top of the valve while the spring is set to have a tension of ninety pounds the valve will remain in its depressed position upon the seat *f* until the pressure in the system with which the chamber *h* cooperates is such as to supply to the chamber *h* a pressure sufficient to exert a force of ten pounds upon the lower end of the valve. Any excess of pressure in the system, it is obvious, will cause the valve to rise and diminish or entirely cut off the supply of gas to the system. Inasmuch as the gas in the space *l*, which is at the main pressure, and the gas in the space *h*, which is at the reduced pressure of the system, act upon the same valve area, the pressure in the system will be reduced to an amount proportional to the difference between the force the main pressure exerts upon the valve-plug and the tension of the spring. An equilibrium will thus be established between the main pressure acting upon the top of the valve on the one hand and between the tension of the spring and the pressure of the reduced gas upon the bottom of the valve on the other hand. The action of the valve-plug will be very quick and positive as soon as this equilibrium is established, inasmuch as the loose fit which the valve has between its inclosing walls eliminates all possible friction in the reciprocation of the valve and as the valve is always perfectly centered and fits its seat squarely. Furthermore, this equilibrium will occur precisely when the pressure in the system has reached a degree proportional to the difference between the main pressure and the tension of the spring, owing to the fact that the pressure of the main supply always exists around the valve-stem, and therefore equal areas of the valve are acted upon, respectively, by the main pressure and the reduced pressure.

I claim as my invention—

1. The combination with a gas-supply and a system to which gas is to be supplied, of a pressure-regulator, having a valve and a valve-casing, said valve and valve-casing being constructed to form a space around the valve for the passage of the gas a space at one end of the valve to receive the gas and a space at the other end of the valve for the return from the system, valve-seats cooperating with each end of the valve to control the communication between the first-mentioned space and the other two spaces respectively, and means to connect the first-mentioned space with the system, the second-mentioned space with the gas-supply and the other space with the return from the system.

2. The combination with a gas-supply and a system to which gas is to be supplied, of a

pressure-regulator, having a valve and a
valve-casing, said valve and valve-casing
being constructed to form a space around the
valve for the passage of the gas a space at one
5 end of the valve to receive the gas and a
space at the other end of the valve for the re-
turn from the system, valve-seats coöperat-
ing with each end of the valve to control the
communication between the first-mentioned

space and the other two spaces respectively 10
and means to discharge the gas from the
space around the valve.

This specification signed and witnessed
this 16th day of March, A. D. 1905.

ANTHONY L. NOONE.

In presence of—

ANTHONY N. JESBERA,
LUCIUS E. VARNEY.