

D. W. HOLLIHAN.

Shoe for Thrashing Machines.

No. 111,541.

Patented Feb. 7, 1871.

Fig. 1.

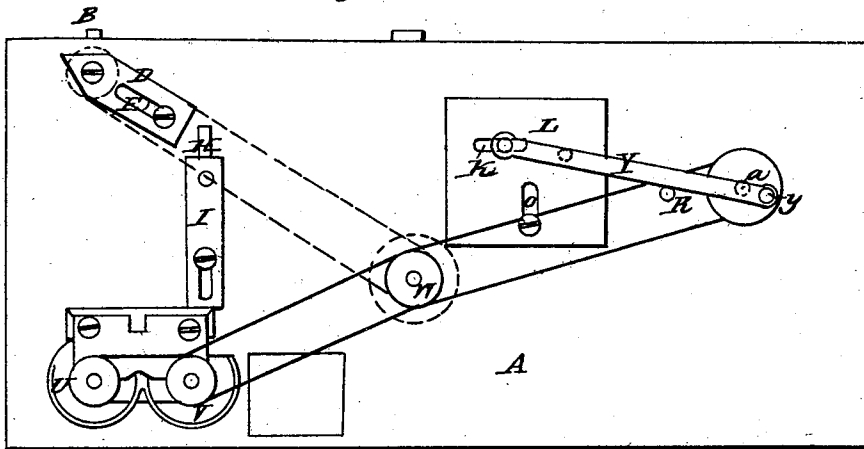
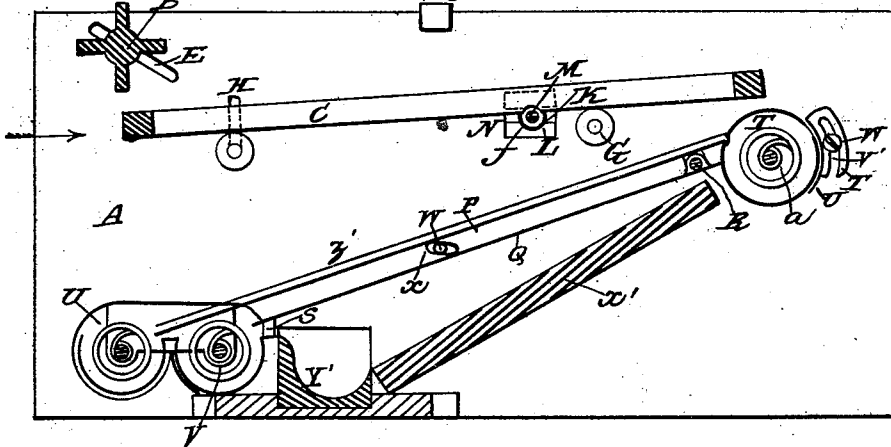

Fig. 2.



Witnesses:
David A. Smith
G. A. Gray

Inventor:
D. W. Hollihan,
By G. W. Smith, atty

United States Patent Office.

DENNIS W. HOLLIHAN, OF SAN FRANCISCO, CALIFORNIA.

Letters Patent No. 111,541, dated February 7, 1871; antedated January 26, 1871.

IMPROVEMENT IN SHOES FOR THRASHERS.

The Schedule referred to in these Letters Patent and making part of the same.

To all whom it may concern:

Be it known that I, DENNIS W. HOLLIHAN, of the city and county of San Francisco, State of California, have invented certain new and useful Improvements in Shoes for Thrashers; and I do hereby declare that the following is a full, clear, and exact description of the same, reference being had to the accompanying drawing and to the letters marked thereon.

My invention relates to certain improvements in that class of machinery for cleaning grain that is attached to and works in connection with thrashing-machines; and consists of certain novel arrangements of screens, screws, and conveyers, with a device for distributing the grain as it comes from the thrasher, an inclined bottom, and a drawer for receiving and saving grass, and mustard, and other fine seeds, together with certain other details of construction that will hereafter more fully appear.

In the accompanying drawing—

Figure 1 is a side elevation, and

Figure 2, a longitudinal section of a machine embodying my invention.

Like letters refer to like parts in each of the figures.

A is the frame.

B is a distributor, employed instead of the board or ribbed apron generally used for receiving the grain as it falls from the thrasher, and conveying it to or distributing it upon the upper sieve or riddle C.

The distributor B has its bearings in the slotted plates D, and can be adjusted in regard to height by means of plates D and slots E.

Sieve C rests upon friction-rollers F and G, and is given a proper inclination by raising or lowering the roller F, made adjustable by means of the slot H and slotted plate I.

The height of the distributor B and the angle of inclination of the sieve C are regulated to correspond to the moist, dry, or other condition of the grain when leaving the thrasher, and the speed at which the machine is running.

The under side of the frame of sieve C is provided with bearings J, opposite which, on the outside of the frame, are horizontal slots K in the adjustable guide-plates L.

Through slots K and bearings J passes loosely a transverse rod, M.

Suitable openings N are made in the frame A, and slot O in the plates L, to provide for the proper adjustment of the parts to correspond to the height of sieve C; but instead of the rod M and bearings J, I prefer to employ gudgeons secured to the under side of sieve C, because it is objectionable to have the rod M extend across under the sieve.

P and Q are screens or sieves, both of which are hinged to the transverse bar R.

To the under side of the sieve Q is attached a spring, S, that constantly tends to force the sieve upward.

T, U, and V are conveyers, that carry the grain-headings or screenings out of the machine to the elevators or receptacles.

Power is applied to the shaft W, the revolutions of which communicate motion to all the moving parts of the machine, to the conveyer-shafts, and distributor B, by means of belts, as shown in the drawing.

A quick or rapid oscillating motion to the sieves P and Q is imparted by means of the cams X, and a rapid reciprocating motion to the sieve C by means of the rods Y connecting crank-pins Z on the extremities of the shaft *a* of the conveyer T to the extremities of the transverse rod M.

Instead of this apparatus for working the screen or sieve C, cams or beaters similar to cams X, attached to a revolving shaft and working against the under side of the frame of that sieve, may be employed.

Z' is a blank screw, to be used when thrashing oats or barley, or when it is desirable to conduct everything that passes the sieve C to the screw U.

The bottom X' is to be sufficiently slanting to run off the seeds that pass through the lower screens into the drawer or trough Y.

U is an adjustable side plate or rim for the conveyer T, that can be raised or lowered and secured at any height by means of the slotted lug-plates T' and screw W'.

The height of this rim is adjusted when the machine is at work for the purpose of intercepting any valuable substance that would be blown away if the rim was not too low, or of allowing chaff and dirt to escape that would be intercepted if the rim was too high.

In attaching this machine to a thrasher it may be so arranged as to admit of raising, or lowering, or tilting, to conform to the direction and force of the blast from the fan of the thrasher.

The operation of my invention is as follows:

The shoe is attached to the thrasher so as to receive the blast from the thrasher-fan in the direction of the arrow, and all the grain, with headings, seeds, chaff, &c., as they come from the cylinder of the thrasher, are thrown and distributed by the distributor B onto the screen C, the wheat and everything smaller than the grain of the wheat passing through the screen, the chaff and dust being blown away by the force of the blast, and the headings and any grain that may be blown over finding its way into the conveyer T.

The wheat being separated from everything smaller

than its grain by the screen P finds its way down the inclined face of said screen to the conveyer U.

All that passes through the screen P is again separated by the screen Q, the broken wheat, &c., finding its way down the face of said screen to screw or conveyer V, and the fine seeds passing through screen Q find their way down the inclined face of the bottom X' to the drawer Y', which can be withdrawn and emptied when full.

Having thus described my invention,

What I claim, and desire to secure by Letters Patent, is—

1. The side plate or rim v' , provided with the slotted lug-plates T', as and for the purpose described.

2. The arrangement of parts hereinafter named, to wit, the frame A, the distributor B, the screens C F Q, and conveyers T U V, when constructed as described, for the purpose set forth.

In testimony whereof I have hereunto set my hand and seal.

D. W. HOLLIHAN. [L. S.]

Witnesses:

C. W. M. SMITH,
H. S. TIBBEY.