



(51) International Patent Classification:

B65F 1/06 (2006.01) B65F 1/16 (2006.01)
B65F 1/10 (2006.01)

(21) International Application Number:

PCT/EP2024/087649

(22) International Filing Date:

19 December 2024 (19.12.2024)

(25) Filing Language:

English

(26) Publication Language:

English

(30) Priority Data:

1044776 02 January 2024 (02.01.2024) NL
2037221 11 March 2024 (11.03.2024) NL

(71) Applicant: **CONFUCIUS HOLDING B.V.** [NL/NL];
Lochemseweg 45, 7214 RD Epse (NL).

(72) Inventor: **MIDDELKOOP, Maarten**; Lochemseweg 45,
7214 RD Epse (NL).

(74) Agent: **ARNOLD & SIEDSMA**; Bezuidenhoutseweg 57,
2594 AC THE HAGUE (NL).

(81) Designated States (unless otherwise indicated, for every
kind of national protection available): AE, AG, AL, AM,

AO, AT, AU, AZ, BA, BB, BG, BH, BN, BR, BW, BY, BZ,
CA, CH, CL, CN, CO, CR, CU, CV, CZ, DE, DJ, DK, DM,
DO, DZ, EC, EE, EG, ES, FI, GB, GD, GE, GH, GM, GT,
HN, HR, HU, ID, IL, IN, IQ, IR, IS, IT, JM, JO, JP, KE, KG,
KH, KN, KP, KR, KW, KZ, LA, LC, LK, LR, LS, LU, LY,
MA, MD, MG, MK, MN, MU, MW, MX, MY, MZ, NA,
NG, NI, NO, NZ, OM, PA, PE, PG, PH, PL, PT, QA, RO,
RS, RU, RW, SA, SC, SD, SE, SG, SK, SL, ST, SV, SY, TH,
TJ, TM, TN, TR, TT, TZ, UA, UG, US, UZ, VC, VN, WS,
ZA, ZM, ZW.

(84) Designated States (unless otherwise indicated, for every
kind of regional protection available): ARIPO (BW, CV,
GH, GM, KE, LR, LS, MW, MZ, NA, RW, SC, SD, SL, ST,
SZ, TZ, UG, ZM, ZW), Eurasian (AM, AZ, BY, KG, KZ,
RU, TJ, TM), European (AL, AT, BE, BG, CH, CY, CZ,
DE, DK, EE, ES, FI, FR, GB, GR, HR, HU, IE, IS, IT, LT,
LU, LV, MC, ME, MK, MT, NL, NO, PL, PT, RO, RS, SE,
SI, SK, SM, TR), OAPI (BF, BJ, CF, CG, CI, CM, GA, GN,
GQ, GW, KM, ML, MR, NE, SN, TD, TG).

(54) Title: DEVICE FOR HOLDING SOILED OBJECTS AND METHOD FOR MAINTAINING AN AIRTIGHT SEAL OF A TRASH BAG DURING INSERTION OF A SOILED OBJECT THEREIN

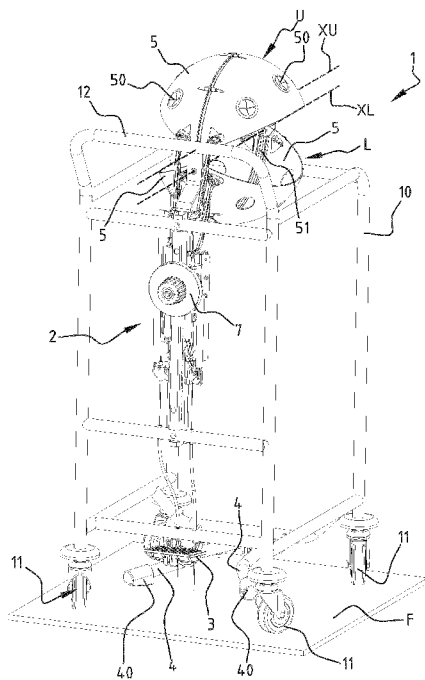

FIG. 2

(57) Abstract: Device (1) for holding soiled objects (OBJ), such as diapers, comprising a lower and an upper clamping hatch (L, U) having an open position and a closed position, and a support frame (10) for supporting them, wherein the upper clamping hatch (U) is higher than the lower clamping hatch (L), wherein the upper clamping hatch (U) comprises mounting means (50) for holding an edge of a trash bag (B), wherein the lower and upper clamping hatch (L, U) define a temporary holding volume (T), wherein the device has an input state and an output state, wherein, in the input state the lower clamping hatch (L) is in the closed position, and the upper clamping hatch (U) is in the open position, and in the output state of the device the lower clamping hatch (L) is in the open position, and the upper clamping hatch (U) is in the closed position. The invention also relates to a related method for maintaining an airtight seal of a trash bag (B) during insertion of a soiled object (OBJ) therein.



Published:

- *with international search report (Art. 21(3))*
- *in black and white; the international application as filed contained color or greyscale and is available for download from PATENTSCOPE*

**DEVICE FOR HOLDING SOILED OBJECTS AND METHOD FOR MAINTAINING AN
AIRTIGHT SEAL OF A TRASH BAG DURING INSERTION OF A SOILED OBJECT
THEREIN**

5

FIELD

The present disclosure relates to a device for holding soiled objects, such as diapers, and a method for maintaining an airtight seal of a trash bag during insertion of a soiled object, such as a diaper, in the trash bag.

10

BACKGROUND

Devices for holding soiled objects, such as diapers, are well known in the art. It is noted that diapers may be baby diapers and/or adult diapers. Soiled objects can further include soiled clothes, wipes, paper, towels, pads, et cetera, without limitations. Soiled object may also be referred to as soiled articles or contaminated objects, or the like. An example of such device can be found in European patent EP 0 776 305, or the like. It is generally desired that an airtight seal of the device, particularly a trash bag placed in the device, is maintained whilst inserting a soiled object in the device. In European patent EP 0 776 305 it is exemplified that this can be achieved, for example, by using a lid containing a channel running through the lid with a piston situated therein, wherein the soiled object can be placed in the channel, and the lid can be subsequently pivoted around such that the piston pushes the soiled object in the trash bag in the device.

Such devices are generally used in the healthcare industry, particularly in hospitals and elderly care, for disposing soiled articles. Healthcare facilities are high-pressure environment, wherein excellent hygiene is of utmost importance when handling soiled articles. Accordingly, there is a need for improvement of both hygiene and efficiency in these devices.

Whilst the known devices are capable of at least partially mitigating smells from leaving the device by means of an airtight seal, the issue that certain surfaces of the device are soiled by the soiled object still remains. Accordingly, these surfaces still require regular cleaning and inspection. It is an object of the present disclosure to provide a device for holding soiled objects, wherein this issue is substantially mitigated or resolved.

SUMMARY

According to a first aspect of the disclosure, a device for holding soiled objects, such as diapers, is provided. The device comprises a lower clamping hatch having an open position and a closed position; an upper clamping hatch having an open position and a closed position; and a support

frame for supporting the upper clamping hatch and the lower clamping hatch, wherein the upper clamping hatch is supported above (e.g., at a higher elevation than) the lower clamping hatch, wherein the upper clamping hatch further comprises mounting means configured for holding an edge of a trash bag, the edge defining an open end of the trash bag, and the trash bag being
5 intended for containing the soiled objects, wherein the lower clamping hatch and the upper clamping hatch define a temporary holding volume therebetween, and wherein the trash bag, in use, is directed (or wherein the trash bag can be directed) from the mounting means downwardly through the upper clamping hatch and the lower clamping hatch (in other words, wherein the upper clamping hatch and the lower clamping hatch, and the temporary holding volume therebetween,
10 are configured for receiving a trash bag therethrough, wherein the trash bag may be held by the mounting means), and wherein the device has at least an input state and an output state, wherein, in the input state of the device: the lower clamping hatch is in the closed position, such that a soiled object cannot pass therethrough and the trash bag, in use, is clamped (or the trash bag can be clamped) thereby (in other words, the lower clamping hatch is configured to clamp the trash bag in
15 the input state of the device), and the upper clamping hatch is in the open position, such that the trash bag, in use, is open, or can be held open, (preferably spread open) at its open end and the soiled object can pass through the open end of the trash bag, in use, and the upper clamping hatch to the temporary holding volume (in other words, the upper clamping hatch is configured to open the trash bag at its open end in the input state of the device); and in the output state of the device:
20 the lower clamping hatch is in the open position, such that the soiled object can pass through the lower clamping hatch from the temporary holding volume into a lower part of the trash bag, in use, and the upper clamping hatch is in the closed position, such that the trash bag, in use, is clamped (or can be clamped) closed thereby at its open end (in other words, the lower clamping hatch is configured to not clamp the trash bag in the output state of the device and the upper clamping hatch
25 is configured to clamp the trash bag in the output state of the device).

The above-proposed device mitigates the issue of soiling/contaminating surfaces of the device, as the soiled object only touches a trash bag installed in the device when the device is correctly used. Particularly, in the input state, the user can input the soiled object through the upper clamping
30 hatch directly into the open end of the trash bag. As the lower clamping hatch is then still closed, the trash bag and its contents are still sealed by the lower clamping hatch, thus preventing (or at least mitigating) foul smells from escaping from the trash bag. When the device subsequently moves from the input state to the output state, the upper clamping hatch seals the trash bag near its open end to prevent (or at least mitigate) foul smells from escaping, and the lower clamping hatch
35 is (preferably temporarily) opened to allow the soiled object to move further into the trash bag where the soiled objects are contained. Accordingly, the present device essentially functions as an

airlock (or “sluice”) for trash bags, whilst simultaneously preventing soiled objects from touching the device itself. Accordingly, the device is not easily contaminated and soiled objects can be disposed whilst preventing smells (e.g., gases or vapor or the like from older soiled objects that are already in the trash bag) from escaping (at least partially) from the trash bag.

5

Optionally, when the device is moved from the input state to the output state, the upper clamping hatch is moved (or is configured to move) to the closed position before the lower clamping hatch is moved (or is configured to move) to the open position. By ensuring that one of the upper clamping hatch and the lower clamping hatch is always closed during normal operation, it is better ensured that escape of smells and the like from the trash bag is mitigated.

10

Optionally, the device further comprises a resting state, wherein, in the resting state of the device: the lower clamping hatch is in the closed position, such that the trash bag is clamped thereby, and the upper clamping hatch is also in the closed position, such that the trash bag is clamped (or can be clamped) closed thereby at its open end. Preferably, the device is biased (or is configured to be biased) to move automatically from the output state to the resting state, preferably by biasing the upper clamping hatch and/or the lower clamping hatch to the closed position. The biasing may be achieved by gravity, resilient elements (e.g., springs) or other methods known to those skilled in the art.

15

20

Optionally, the device further comprises a service state, wherein, in the service state of the device: the lower clamping hatch and the upper clamping hatch are both in the open position, such that the trash bag can be removed, inserted, and/or replaced. In the service state, the upper and lower clamping hatches are preferably manually locked in the open position, for instance by a control element, such as a knob, that can be operated to lock certain parts of the mechanism for moving the hatches.

25

Optionally, the device further comprises a lever configured to move the upper clamping hatch and the lower clamping hatch into their respective open position and closed positions. Preferably, the lever is a pedal, and more preferably a foot pedal. Even further preferably, depressing the pedal moves the upper clamping hatch from its closed position to its open position, so as to bring the device in its input state, and further loads or energizes (e.g., charges) a movement mechanism that configured to engage with the lower clamping hatch; and releasing the pedal moves the upper clamping hatch from its open position to its closed position, and further moves the lower clamping hatch from its closed position to its open position by engagement of the movement mechanism, thus bringing the device in its output state. Additionally or alternatively, the movement mechanism

30

35

may comprise a spring (e.g., torsion, compression, extension and/or gas spring), or an electromechanical element that is capable of being energized by mechanical force and subsequently releasing that energy as another mechanical force, such as an opposite mechanical force opposite to the energizing mechanical force. Accordingly, with a single action of the user, e.g., depressing and later releasing a pedal by foot, the entire cycle from input state to output state, and preferably subsequently the resting state, can be achieved. For instance, when depressing the pedal, a first part of the movement of the pedal may actuate the upper clamping hatch, and a second part of the movement of the pedal may load or energize (e.g., charge) the movement mechanism. For instance, when releasing the pedal, a first part of the movement of pedal may actuate the upper clamping hatch, and a second part of the movement may activate the movement mechanism to actuate the lower clamping hatch.

Further preferably, the device comprises a first actuation element mechanically connected with the upper clamping hatch; a second actuation element mechanically connected with the lower clamping hatch; and a third actuation element mechanically connected with and movable by the pedal, wherein: the first actuation element has a first engagement member, and the third actuation element has a third engagement member configured to engage with the first engagement member when the pedal is depressed, such that the first actuation element can be moved by the pedal, through the third actuation element, in a first direction by depressing the pedal, wherein movement of the first actuation element in the first direction causes the upper clamping hatch to move from the closed position to the open position, the second actuation element has a second engagement member, and the movement mechanism is connected with the third actuation element and has a first position and a second position, and further comprises a fourth engagement member configured to engage with the second engagement member of the second actuation element in the second position of the movement mechanism, wherein the movement mechanism is biased towards the second position (preferably by a resilient element, such as a torsion spring) when the pedal is depressed, such that the second actuation element can be moved by the third actuation element, through the movement mechanism, in a second direction when the pedal is released, wherein movement of the second actuation element in the second direction causes the lower clamping hatch to move from the closed position to the open position.

Even further preferably, the first actuation element further comprises a first disengagement portion and the movement mechanism comprises a second disengagement portion, wherein the first disengagement portion is configured to engage with the second disengagement portion when the movement mechanism is in the second position and the pedal is released, and wherein engagement of the first disengagement portion and the second disengagement portion moves the movement

mechanism to the first position. This arrangement allows for the upper and lower clamping hatch to be operated in a specific order, such that the trash bag, in use, is always clamped by either the upper or the lower clamping hatch during normal operation. Particularly, when depressing the pedal the upper clamping hatch is opened, and the movement mechanism is engaged (e.g.,
5 activated, charged, energized, etc.). When subsequently releasing the pedal, the upper clamping hatch is closed first, wherein the closing action of the upper clamping hatch activates the movement mechanism which subsequently opens the lower clamping hatch until the pedal is released further and the movement mechanism is disengaged by engagement of the disengagement portions. The movement of the parts as described above is further exemplified below by means of
10 the figures and accompanying description thereof.

Optionally, the upper clamping hatch and/or the lower clamping hatch comprise a first hatch part and a second hatch part, wherein, in the closed position, the first and second hatch parts abut each other, so as to be able to clamp the trash bag therebetween, and, in the open position, the first and
15 second hatch parts are moved apart from each other. Preferably, the first and second hatch parts are each a spherical shell wedge, pivotable about a common pivot axis, wherein both end points of each wedge are positioned on the common pivot axis, more preferably wherein each spherical shell wedge is identical. Preferably, when the two spherical shell wedges abut each other in the closed position, they essentially delimit a spherical shell wedge double the size of each of the two
20 spherical shell wedges. It is preferred that at least part of an abutment surface of the first hatch part and/or the second hatch part is covered by a resilient sealing material, such as an elastomer, the abutment surface being a contact surface between the first and second hatch parts in the closed position. The resilient sealing material may for instance be a rubber, but may also be a flexible piece of plastic or the like. Other sealing materials, or sealing strips or the like, will be apparent to
25 those skilled in the art.

Preferably, the upper clamping hatch and/or the lower clamping hatch are configured to clamp the trash bag, in the closed position, with sufficient force to clamp the trash bag in an airtight manner. More preferably, the lower clamping hatch is further configured to clamp the trash bag, in the
30 closed position, with a force that still allows the trash bag to slide through the lower clamping hatch whilst maintaining an airtight seal. This allows for some play of the bag between the upper and lower clamping hatches. Particularly, when the lower clamping hatch is closed and the upper clamping hatch moves from the open position to the closed position, the bag can be pulled upwards by the upper clamping hatch, which is preferably not hindered by the lower clamping hatch.
35 Otherwise, the material of the trash bag may be stressed which can potentially cause damage (e.g., tearing).

Optionally, the mounting means of the upper clamping hatch are placed on an exterior surface of the upper clamping hatch. Accordingly, a trash bag installed in the device runs from the exterior of the device through the upper and lower clamping hatches downwardly, and thus hangs from the
5 upper clamping hatch.

Preferably, the support frame comprises a housing to enclose the trash bag. This conceals the trash bag from sight, and also enables for the soiled objects to be caught in case the trash bag is damaged, therefore preventing soiling of the surroundings of the device.

10

According to a second aspect of the disclosure, a method for maintaining an airtight seal of a trash bag during insertion of a soiled object therein is provided. The method comprises the steps of: clamping the trash bag closed, in an airtight manner, at a first location near an open end of the trash bag, and simultaneously clamping the trash bag closed, in an airtight manner, at a second location
15 away from the open end of the trash bag and the first location; subsequently releasing the clamp at the first location, and inserting the soiled object in the trash bag between the first and second locations; after inserting the soiled object in the trash bag between the first and second locations, re-establishing the clamp at the first location and subsequently releasing the clamp at the second location, such that the soiled object is inserted in the trash bag whilst maintaining the airtight seal
20 of the trash bag to the exterior of the trash bag.

Optionally, the method is performed using the device according to the first aspect of the disclosure, wherein clamping the trash bag at the first location is effected by the upper clamping hatch and clamping the trash bag at the second location is effected by the lower clamping hatch. Preferably,
25 an edge of the trash bag, defining its open end, is attached to the upper clamping hatch at an external portion thereof, more preferably by means of the mounting means.

BRIEF DESCRIPTION OF THE DRAWINGS

FIGS. 1A – 1E show a schematic view of operation principles for a device for maintaining an
30 airtight seal of a trash bag during insertion of a soiled object therein;
FIG. 2 shows a perspective view of an exemplary device for maintaining an airtight seal of a trash bag during insertion of a soiled object therein;
FIG. 3 shows another perspective view of the exemplary device of FIG. 2;
FIG. 4 shows a detailed perspective view of the device of FIGS. 2 and 3;
35 FIG. 5 shows upper and lower clamping hatches in a resting state of a device for maintaining an airtight seal of a trash bag during insertion of a soiled object therein;

FIG. 6 shows upper and lower clamping hatches in an input state of the device;
FIG. 7 shows upper and lower clamping hatches in an output state of the device;
FIG. 8 shows upper and lower clamping hatches in a service state of the device;
FIG. 9 shows schematically an operation mechanism for operating upper and lower clamping
5 hatches of an exemplary device for maintaining an airtight seal of a trash bag during insertion of a
soiled object therein;
FIG. 10 shows an exemplary implementation of the schematic depiction of the operation
mechanism according to FIG. 9;
FIGS. 11A – 11F schematically show the operation principles of an exemplary device for
10 maintaining an airtight seal of a trash bag during insertion of a soiled object therein, by showing
several states of the device;
FIGS. 12 and 13 show two relative positions of actuation elements of the mechanism of FIG. 10
useful for understanding disengagement of a movement mechanism;
FIG. 14 shows an overview of an operation mechanism in an assembled state for a device for
15 maintaining an airtight seal of a trash bag during insertion of a soiled object therein; and
FIGS. 15 – 18 show various perspectives of an operation mechanism, useful for understanding the
service state of a device for maintaining an airtight seal of a trash bag during insertion of a soiled
object therein.

20

DETAILED DESCRIPTION

FIGS. 1A – 1E show a schematic view of operation principles for a device 1 for maintaining an
airtight seal of a trash bag B during insertion of a soiled object OBJ therein. In FIG. 1A the device
1 is in a resting state, in FIG. 1B the device 1 is in an input state, in FIG. 1C the device 1 is in a
temporary holding state, in FIG. 1D the device 1 is in an output state, and in FIG. 1E the device 1
25 is in a service state. Hereafter, each of the depicted states is explained in further detail.

In the resting state (FIG. 1A), the upper clamping hatch U of the device 1 is in the closed position,
and the lower clamping hatch L is also in the closed position. The upper clamping hatch U and
lower clamping hatch L may also be referred to as upper lid U and lower lid L, respectively. In
30 their closed positions the upper lid U and lower lid L clamp the trash bag B at a first position P1
and a second position P2, respectively. This means that the trash bag B is sealed, preferably air
tight, at the first position P1 and the second position P2. Accordingly, foul smells from the interior
I of the bag B are prevented from escaping from the bag B in the resting state of the device 1.

35 In the input state of the device 1 (FIG. 1B), the upper lid U is in the opened position and the lower
lid L is in the closed position. The bag B is attached to the upper lid U, at an exterior portion

thereof, such that opening the upper lid U also opens the open end of the trash bag B, as shown. This allows for a user to insert a soiled object OBJ into the bag B. As the lower lid L is still in the closed position, the trash bag B, particularly the interior I thereof, is still sealed. Therefore, also in the input state, foul smells from the interior I of the bag B are prevented from escaping from the
5 bag B.

The temporary holding state of the device 1 (FIG. 1C) is a temporary state when the device 1 moves from the input state (FIG. 1B) to the output state (FIG. 1D). Similar to the resting state, the upper lid U and lower lid L are closed in the temporary holding state. A temporary holding volume
10 T is formed between the upper lid U and lower lid L, such that the soiled object OBJ can temporarily be held between the upper and lower lids U, L. The temporary holding state ensures that foul smells from the interior I of the bag B are prevented from escaping from the bag B when moving from the input state (FIG. 1B) to the output state (FIG. 1D). Particularly, if the device 1 would move to the output state (FIG. 1D) from the input state (FIG. 1B) instantaneously, there
15 would be a period wherein both the upper lid U and the lower lid L are opened, such that foul smells would be able to escape. This is thus effectively prevented by the temporary holding state.

In the output state (FIG. 1D), the upper lid U is in the closed position and the lower lid L is in the open position. This allows the object OBJ to move from the temporary holding volume T to the
20 interior I of the bag B to be held there. As the upper lid U clamps the bag B in the first position P1, also in this case foul smells from the interior I of the bag B are prevented from escaping from the bag B.

Lastly, in the service state of the device 1 (FIG. 1E) both the upper lid U and the lower lid L are
25 opened. This is a special state wherein the bag B can be removed, replaced and installed in the device 1. In practice, one would manually clamp the bag B below the second position P2, e.g., at a third position P3, before bringing the device 1 in the service state, such that still no foul smells would escape from the bag. Accordingly, it is possible to prevent smells from escaping throughout the entire use of the device 1, from installing the bag B to replacing it when it is full.

30
FIG. 2 shows a device 1 for maintaining an airtight seal of a trash bag B (not shown here) during insertion of a soiled object OBJ (not shown here) therein. The device 1 has an upper clamping hatch U and a lower clamping hatch L, also referred to as upper lid U and lower lid L, respectively, which can be operated as described above regarding FIGS. 1A – 1E. The upper lid U and lower lid
35 L can be operated by means of an operating mechanism 2, which is described in further detail below. The upper lid U, lower lid L, and operating mechanism 2 are supported on a frame 10 of the

device 1. The device 1 can be placed on a floor F, and can be supported on swiveling wheels 11 connected with the frame 10. The user can push the device 1 around by engaging the handle bar 12 of the frame 10. The operating mechanism 2 is operable by a user (not shown) through a foot pedal 3. Depressing and releasing the foot pedal 3 leads the device 1 from its initial resting state (as shown here and in FIG. 1A) through the input state (see FIG. 1B), temporary holding state (see FIG. 1C), output state (see FIG. 1D) and back to its resting state (as shown here in FIG. 2 as well as schematically in FIG. 1A). The foot pedal 3 is also coupled with a braking mechanism 4. When depressing the pedal 3 the braking mechanism 4 is pivoted downwards until the brake pads 40 touch the floor F. The braking mechanism 4 prevents the device 1 from rolling away when the user depresses the foot pedal 3. The brake pads 40 can for instance be made of rubber for increased friction with the floor F.

The upper lid U and lower lid L are both formed by two spherical shell wedges 5, which are in the present example identical, such that they can be manufactured from a single mold. The wedges 5 of the upper lid U are provided with mounting points 50 to which the trash bag B (not shown) can be mounted, in use. In the present example, an edge of a trash bag B can be wedged into place in the mounting points 50, such that the trash bag B is suspended from the wedges 5 of the upper lid U. In FIG. 2 the upper lid U and lower lid L are in the closed position, which means that the respective two wedges 5 of the upper lid U and those of the lower lid L abut each other at their clamping interface 51. The clamping interface 51 can be provided with a resilient material to form a better seal between the two wedges 5, thereby forming a better seal for the trash bag B installed therebetween. In use, the trash bag B is led from the mounting points 50, through the interface 51 of the upper lid U and then through the interface 51 of the lower lid L, and further downwards. As the wedges 5 are identical in the present example, the upper lid U has an upper pivot axis XU and the lower lid L has a lower pivot axis XL. This enables the device 1 to have the service state (see FIG. 1E), wherein both the upper lid U and lower lid L are opened to remove, replace or insert a trash bag B. If the upper lid U and lower lid L had the same pivot axis, one would not be able to use identical wedges 5, as they would then collide in the service state.

FIGS. 3 and 4 show the device 1 of FIG. 2 from other perspectives, wherein parts are denoted with the same reference signs as in FIG. 2. In FIG. 4, the device 1 is shown in closer detail. It can be seen that the upper lid U is operated by actuation rods 6U, and the lower lid L is operated by actuation rods 6L. When the actuation rods 6U of the upper lid U are pulled downwards, the two wedges 5 of the upper lid U are pivoted about the upper pivot axis XU to bring the upper lid U in its open position (shown, e.g., in FIG. 6). When the actuation rods 6L of the lower lid L are pushed upwards, the two wedges 5 of the lower lid L are pivoted about the lower pivot axis XL to bring

the lower lid L in its open position (shown, e.g., in FIG. 7). The actuation rods 6U, 6L are operated by the operation mechanism 2, as further explained below. The operation mechanism 2 also has a service knob 7, which can be turned to enable the user to lock the upper lid U and lower lid L in the service state (see, e.g., FIG. 1E) wherein the upper lid U and lower lid L are both in the open position. The service knob 7 is further explained below.

In FIGS. 5 – 8, the upper lid U and lower lid L of the device of FIGS. 2 – 4 are isolated and shown in various positions corresponding to various states of the device 1. In FIG. 5 the device 1 is in the resting state, in FIG. 6 the device 1 is in the input state, in FIG. 7 the device 1 is in the output state, and in FIG. 8 the device 1 is in the service state. In the resting state of FIG. 5, the upper lid U and lower lid L are both in the closed position. In the input state of FIG. 6, the upper lid U is in the open position and the lower lid L is in the closed position. In the output state of FIG. 7, the upper lid U is in the closed position and the lower lid L is in the open position. In the service state of FIG. 8 the upper lid U and lower lid L are both in the open position.

FIG. 9 shows a schematic drawing of the operation mechanism 2 of a device 1 as mentioned above, and FIG. 10 shows the isolated operating mechanism 2 as embodied in FIGS. 2 – 4. In FIGS. 9 and 10, the components of the operation mechanism 2 are briefly introduced. In FIGS. 11A – 11F the operation principles are explained in further detail.

The operation mechanism 2 comprises a first actuation element 21, a second actuation element 22, and a third actuation element 23. The first actuation element 21 can be coupled with the upper lid U, particularly the actuation rods 6U thereof. Moving the first actuation element 21 downwards thus moves the upper lid U from the closed position to the open position. The second actuation element 22 can be coupled with the lower lid L, particularly the actuation rods 6L thereof. Moving the second actuation element 22 upwards thus moves the lower lid L from the closed position to the open position. The third actuation element 23 is coupled with the foot pedal 3 (not shown here), for instance by tethers 30. The mechanism 2 further comprises a movement mechanism 20, that is pivotally coupled with the third actuation element 23. The movement mechanism 20 is provided with a biasing member 200, which is here embodied as a torsion spring 200. The torsion spring 200 biases the movement mechanism 20 to rotate in the clockwise direction CW as indicated. In the presently shown situation, movement of the movement mechanism 20 in the clockwise direction CW is blocked by the second actuation element 22. The first actuation element 21, second actuation element 22, and third actuation element 23 are all biased to their resting positions by, respectively, a first biasing spring 210, a second biasing spring 220, and a third biasing spring 230, which are all anchored to the frame 10 of the device 1, which is shown schematically here. The

resting positions of the first second and third actuation elements 21, 22, 23 correspond the positions these elements take in the resting state of the device 1, i.e., a state wherein both the upper lid U and the lower lid L are closed, thus clamping the trash bag B at a first position P1 and a second position P2.

5

The first, second, and third actuation elements 21, 22, 23, in the shown example in FIG. 9, are movable in the vertical direction, i.e., upwards and downwards. The first actuation element 21 further comprises a first engagement member 211, and the third actuation member 23 comprises a third engagement member 231 configured to engage with the first engagement member 211 when
10 the pedal 3 is depressed, as will become apparent in FIGS. 11A – 11F. This means that the first actuation member 21 can be moved by means of the pedal 3, through the third actuation member 23. The second actuation member 22 comprises a second engagement member 221, and the movement mechanism 20 comprises a fourth engagement member 201. The fourth engagement member 201 is configured to engage with the second engagement member 221 of the second
15 actuation element 22 in a second position (not shown here) of the movement mechanism 20. In the shown example of FIG. 9, the movement mechanism is in its first position. Once the third actuation element 23 is moved downwardly far enough (by depressing the pedal 3) the fourth engagement member 201 passes the second engagement member 221, such that the movement mechanism springs into its second position, as it is biased by the torsion spring 200 to do so. Accordingly, the
20 fourth engagement member 201 and second engagement member 221 can then engage with each other. When this is the case, upward movement of the third actuation element 23, and thus the movement mechanism 20, causes the second actuation element 22 to move upward, thereby moving the lower lid L to its open position, as will become apparent in FIGS. 11A – 11F.

25 The first actuation element 21 further comprises a first disengagement portion 212, and the movement mechanism 20 comprises a second disengagement portion 202. The first disengagement portion 212 is configured to engage with the second disengagement portion 202 when the movement mechanism 20 is in the second position (not shown here). Engagement of the first disengagement portion 212 and the second disengagement portion 202 moves the movement
30 mechanism 20 to the first position, as shown here in FIG. 9.

FIG. 10 shows an implementation of the schematic depiction of the operation mechanism 2 according to FIG. 9. Components are denoted by the corresponding reference signs. Additionally, two gear racks 213, 223 are shown in FIG. 10. The first actuation element 21 comprises a first gear rack 213, and the second actuation element 22 comprises a second gear rack 223. The gear racks
35 213, 223 can each be engaged by resistance gear wheels 214, 224 (not shown here). The racks 213,

223 and resistance gear wheels damp the motion of the first and second actuation elements 21, 22 towards their resting positions, such that the movements of the actuation elements 21, 22 in both directions (upward and downwards) are smooth and not sudden.

5 FIG. 11A shows the device 1 in the resting state, with the upper lid U and lower lid L in the closed positions. The pedal 3 is also in the resting position, and ready to be engaged by a user. When the pedal 3 is depressed by a user, the device 1 goes into the input state (FIG. 11B). It can be seen that the pedal 3 pulls the third actuation element 23 downwards, such that the third engagement member 231 engages with the first engagement member 211 and the first actuation element 21 is
10 pulled down together with the third actuation element 23, thereby bringing the upper lid U in the open position as shown (FIG. 11B). Accordingly, the device 1 is then in its input state in FIG. 11B. It can also be seen that the movement mechanism 20 moves with the third actuation element 23 until it clears the second actuation element 22, such that the movement mechanism 20 moves in clockwise direction CW to its second position (as shown in FIG. 11B) by means of the torsion
15 spring 200. This means that the fourth engagement member 201 of the movement mechanism 20 is now in position to engage with the second engagement member 221 of the second actuation element 22. Thus, when the pedal is released (FIG. 11C) the second engagement member 221 and fourth engagement member 201 come into contact with each other as the third actuation element 23 moves back upwards. Also, the upper lid U is closed again due to upward movement of the first
20 actuation element 21. Accordingly, the device 1 is in its temporary holding state in FIG. 11C.

When the pedal 3 is released further, the second actuation element 22 moves upwards with the third actuation element 23 through engagement with the movement mechanism 20, thereby opening the lower lid L. Accordingly, the device 1 goes into its output state, as shown in FIG. 11D.
25 Also, it can be seen that the first engagement member 211 and third engagement member 231 are now disengaged.

In FIG. 11E, the pedal 3 is released even further as compared to FIG. 11D. This means that the first disengagement portion 212 of the first actuation element 21 comes into contact with the second
30 disengagement portion 202 of the movement mechanism 20, such that the movement mechanism is eventually pushed back to its resting position, being its first position (as shown in FIG. 11F). This engagement between the first and second disengagement portions 202, 212 forces movement of the movement mechanism 20 against the spring force of the torsion spring 200, which biases the movement mechanism 20 towards its second position.

As shown in FIG. 11F, the fourth engagement member 201 of the movement mechanism 20 eventually clears the second engagement member 221 of the second actuation element 22, the first, second and third actuation elements 21, 22, 23 will automatically move back to their resting positions, as also shown for instance in FIG. 11A.

5

FIGS. 12 and 13 utilize the same reference signs as the FIGS. described above, and illustrate the relative movement of the first actuation element 21 and third actuation element 23 with respect to the movement mechanism 20, to illustrate how the first disengagement portion 212 engages with the second disengagement portion 202. In FIG. 12 the disengagement portions 202, 212 are still
10 apart, and in FIG. 13 the disengagement portions 202, 212 are into contact. This thus illustrates a situation in which the pedal 3 is released. The first disengagement portion 212 will eventually push the movement mechanism 20 back to its first position, such that the second actuation element 22 is free to move back downwards, such that the lower lid L is brought into its closed position.

15

FIG. 14 gives an overview of the operation mechanism 2 in an assembled state. In addition to the FIGS. described above, the first biasing spring 210, second biasing spring 220, and third biasing spring 230 are shown, as well as the resistance gear wheels 214, 224 that engage with the gear racks 213, 223.

20

Finally, FIGS. 15 – 18 illustrate how the device 1 can be brought into its service state, in which both the upper lid U and the lower lid L are opened, such that a trash bag B (not shown here) can be removed, inserted or replaced. The user can bring the device 1 in the service state by turning the service knob 7. The service knob 7 comprises a rotation plate 70 that rotates with the knob 7, and two service plates 71, that extend from the rotation plate 70 in a direction away from the operation
25 mechanism 2. The service plates 71 are inclined, as can be seen in the FIGS. As seen in for instance FIG. 16, the operation mechanism 2 further comprises a service state mechanism 8, with two service paddles 80U, 80L. The paddles 80U, 80L can rotate about a pivot axis 81. The paddles 80U, 80L are further engaged by two spring-loaded rods 82. The spring-loaded rods 82 are biased towards the knob 7. It can be seen in FIG. 16 that the rods 82 engage with the rotation plate 70, in
30 which case the device 1 is not in the service state, but instead in the normal operating state. This normal operating state is also shown in FIG. 17. In FIG. 18, instead the knob 7 is turned to the service state position, which means that the two service plates 71 align with the spring-loaded rods 82, which are thus allowed to move the paddles 80U, 80L in direction of the knob 7. In this position as shown in FIG. 18, the first paddle 80U is configured to engage with a service catch 9U
35 of the first actuation element 21, and the second paddle 80L is configured to engage with a service

catch 9L of the second actuation element 22. The service catch 9U of the first actuation element 21 corresponds to the first engagement member 211.

The figures and the description thereof presented herein are not to be construed as limiting the scope of the disclosure, particularly the claims, to any extent, but merely as illustrative examples used to elucidate the present disclosure and invention(s) described therein.

CLAUSES

The disclosure further comprises the following clauses:

10

1. Device for holding soiled objects, such as diapers, comprising:
 - a lower clamping hatch having an open position and a closed position;
 - an upper clamping hatch having an open position and a closed position; and
 - a support frame for supporting the upper clamping hatch and the lower clamping
- 15 hatch, wherein the upper clamping hatch is supported above the lower clamping hatch, wherein the upper clamping hatch further comprises mounting means configured for holding an edge of a trash bag, the edge defining an open end of the trash bag, and the trash bag being intended for containing the soiled objects,
- wherein the lower clamping hatch and the upper clamping hatch define a
- 20 temporary holding volume therebetween, and wherein the trash bag, in use, is directed from the mounting means downwardly through the upper clamping hatch and the lower clamping hatch, and
- wherein the device has at least an input state and an output state, wherein,
- in the input state of the device:

25

the lower clamping hatch is in the closed position, such that a soiled object cannot pass therethrough and the trash bag, in use, is clamped thereby, and

the upper clamping hatch is in the open position, such that the trash bag, in use, is open at its open end and the soiled object can pass through the open end of the trash bag, in use, and the upper clamping hatch to the temporary holding volume; and

30

in the output state of the device:

the lower clamping hatch is in the open position, such that the soiled object can pass through the lower clamping hatch from the temporary holding volume into a lower part of the trash bag, in use, and

the upper clamping hatch is in the closed position, such that the trash bag, in use, is clamped closed thereby at its open end.

35

2. Device according to clause 1, wherein, when the device is moved from the input state to the output state, the upper clamping hatch is moved to the closed position before the lower clamping hatch is moved to the open position.
- 5 3. Device according to clause 1 or 2, the device further comprising a resting state, wherein, in the resting state of the device:
the lower clamping hatch is in the closed position, such that the trash bag is clamped thereby, and
the upper clamping hatch is also in the closed position, such that the trash bag is
10 clamped closed thereby at its open end.
4. Device according to clause 3, wherein the device is biased to moves automatically from the output state to the resting state, preferably by biasing the upper clamping hatch and/or the lower clamping hatch to the closed position.
15
5. Device according to any one of clauses 1-4, the device further comprising a service state, wherein, in the service state of the device:
the lower clamping hatch and the upper clamping hatch are both in the open position, such that the trash bag can be removed, inserted, and/or replaced.
20
6. Device according to any one of clauses 1-5, the device further comprising a lever configured to move the upper clamping hatch and the lower clamping hatch into their respective open position and closed positions.
- 25 7. Device according to clause 6, wherein the lever is a pedal, preferably a foot pedal.
8. Device according to clause 7, wherein:
depressing the pedal moves the upper clamping hatch from its closed position to its open position, so as to bring the device in its input state, and further loads or energizes a movement mechanism that configured to engage with the lower clamping hatch; and
30 releasing the pedal moves the upper clamping hatch from its open position to its closed position, and further moves the lower clamping hatch from its closed position to its open position by engagement of the movement mechanism, thus bringing the device in its output state.
35

9. Device according to clause 8, further comprising:
a first actuation element mechanically connected with the upper clamping hatch;
a second actuation element mechanically connected with the lower clamping hatch;
and
5 a third actuation element mechanically connected with and movable by the pedal,
wherein:
the first actuation element has a first engagement member, and the third
actuation element has a third engagement member configured to engage with the first
engagement member when the pedal is depressed, such that the first actuation element can
10 be moved by the pedal, through the third actuation element, in a first direction by
depressing the pedal, wherein movement of the first actuation element in the first direction
causes the upper clamping hatch to move from the closed position to the open position,
the second actuation element has a second engagement member, and
the movement mechanism is connected with the third actuation element
15 and has a first position and a second position, and further comprises a fourth engagement
member configured to engage with the second engagement member of the second
actuation element in the second position of the movement mechanism, wherein the
movement mechanism is biased towards the second position when the pedal is depressed,
such that the second actuation element can be moved by the third actuation element,
20 through the movement mechanism, in a second direction when the pedal is released,
wherein movement of the second actuation element in the second direction causes the
lower clamping hatch to move from the closed position to the open position.
10. Device according to clause 9, wherein the first actuation element further comprises
25 a first disengagement portion and the movement mechanism comprises a second
disengagement portion, wherein the first disengagement portion is configured to engage
with the second disengagement portion when the movement mechanism is in the second
position and the pedal is released, and wherein engagement of the first disengagement
portion and the second disengagement portion moves the movement mechanism to the first
30 position.
11. Device according to any of the preceding clauses, wherein the upper clamping
hatch and/or the lower clamping hatch comprise:
a first hatch part and a second hatch part, wherein, in the closed position, the first
35 and second hatch parts abut each other, so as to be able to clamp the trash bag
therebetween, and, in the open position, the first and second hatch parts are moved apart

from each other.

12. Device according to clause 11, wherein the first and second hatch parts are each a spherical shell wedge, pivotable about a common pivot axis, wherein both end points of each wedge are positioned on the common pivot axis, preferably wherein each spherical shell wedge is identical.
13. Device according to clause 11 or 12, wherein at least part of an abutment surface of the first hatch part and/or the second hatch part is covered by a resilient sealing material, such as an elastomer, the abutment surface being a contact surface between the first and second hatch parts in the closed position.
14. Device according to any of the preceding clauses, wherein the upper clamping hatch and/or the lower clamping hatch are configured to clamp the trash bag, in the closed position, with sufficient force to clamp the trash bag in an airtight manner.
15. Device according to clause 14, wherein, the lower clamping hatch is further configured to clamp the trash bag, in the closed position, with a force that still allows the trash bag to slide through the lower clamping hatch whilst maintaining an airtight seal.
16. Device according to any of the preceding clauses, wherein the mounting means of the upper clamping hatch are placed on an exterior surface of the upper clamping hatch.
17. Method for maintaining an airtight seal of a trash bag during insertion of a soiled object, such as a diaper, in the trash bag, comprising the steps of:
clamping the trash bag closed, in an airtight manner, at a first location near an open end of the trash bag, and simultaneously clamping the trash bag closed, in an airtight manner, at a second location away from the open end of the trash bag and the first location;
subsequently releasing the clamp at the first location, and inserting the soiled object in the trash bag between the first and second locations;
after inserting the soiled object in the trash bag between the first and second locations, re-establishing the clamp at the first location and subsequently releasing the clamp at the second location, such that the soiled object is inserted in the trash bag whilst maintaining the airtight seal of the trash bag to the exterior of the trash bag.

18. Method of clause 17, using the device of any one of clauses 1 – 16, wherein clamping the trash bag at the first location is effected by the upper clamping hatch and clamping the trash bag at the second location is effected by the lower clamping hatch.
- 5
19. Method of clause 18, wherein an edge of the trash bag, defining its open end, is attached to the upper clamping hatch at an external portion thereof, preferably by means of the mounting means.

CLAIMS

1. Device for holding soiled objects, such as diapers, comprising:
a lower clamping hatch having an open position and a closed position;
5 an upper clamping hatch having an open position and a closed position; and
a support frame for supporting the upper clamping hatch and the lower clamping hatch, wherein the upper clamping hatch is supported above the lower clamping hatch,
wherein the upper clamping hatch further comprises mounting means configured for holding an edge of a trash bag, the edge defining an open end of the trash bag, and the
10 trash bag being intended for containing the soiled objects,
wherein the lower clamping hatch and the upper clamping hatch define a temporary holding volume therebetween, and wherein the trash bag can be directed from the mounting means downwardly through the upper clamping hatch and the lower clamping hatch, and
15 wherein the device has at least an input state and an output state, wherein,
in the input state of the device:
the lower clamping hatch is in the closed position, such that a soiled object cannot pass therethrough and the trash bag can be clamped thereby, and
the upper clamping hatch is in the open position, such that the trash bag
20 can be held open at its open end and the soiled object can pass through the open end of the trash bag and the upper clamping hatch to the temporary holding volume; and
in the output state of the device:
the lower clamping hatch is in the open position, such that the soiled object
25 can pass through the lower clamping hatch from the temporary holding volume into a lower part of the trash bag, and
the upper clamping hatch is in the closed position, such that the trash bag can be clamped closed thereby at its open end.
2. Device according to claim 1, wherein, when the device is moved from the input
30 state to the output state, the upper clamping hatch is configured to move to the closed position before the lower clamping hatch moves to the open position.
3. Device according to claim 1 or 2, the device further comprising a resting state,
wherein, in the resting state of the device:
35 the lower clamping hatch is in the closed position, such that the trash bag can be clamped thereby, and

the upper clamping hatch is also in the closed position, such that the trash bag can be clamped closed thereby at its open end.

4. Device according to claim 3, wherein the device is biased to moves automatically
5 from the output state to the resting state, preferably by biasing the upper clamping hatch and/or the lower clamping hatch to the closed position.
5. Device according to any one of claims 1-4, the device further comprising a service
state, wherein, in the service state of the device:
10 the lower clamping hatch and the upper clamping hatch are both in the open position, such that the trash bag can be removed, inserted, and/or replaced.
6. Device according to any one of claims 1-5, the device further comprising a lever
15 configured to move the upper clamping hatch and the lower clamping hatch into their respective open position and closed positions.
7. Device according to claim 6, wherein the lever is a pedal, preferably a foot pedal.
8. Device according to claim 7, wherein:
20 depressing the pedal moves the upper clamping hatch from its closed position to its open position, so as to bring the device in its input state, and further loads or energizes a movement mechanism that configured to engage with the lower clamping hatch; and
releasing the pedal moves the upper clamping hatch from its open position to its
25 closed position, and further moves the lower clamping hatch from its closed position to its open position by engagement of the movement mechanism, thus bringing the device in its output state.
9. Device according to claim 8, further comprising:
a first actuation element mechanically connected with the upper clamping hatch;
30 a second actuation element mechanically connected with the lower clamping hatch;
and
a third actuation element mechanically connected with and movable by the pedal,
wherein:
35 the first actuation element has a first engagement member, and the third actuation element has a third engagement member configured to engage with the first engagement member when the pedal is depressed, such that the first actuation element can

be moved by the pedal, through the third actuation element, in a first direction by depressing the pedal, wherein movement of the first actuation element in the first direction causes the upper clamping hatch to move from the closed position to the open position,

the second actuation element has a second engagement member, and

5 the movement mechanism is connected with the third actuation element and has a first position and a second position, and further comprises a fourth engagement member configured to engage with the second engagement member of the second actuation element in the second position of the movement mechanism, wherein the movement mechanism is biased towards the second position when the pedal is depressed, 10 such that the second actuation element can be moved by the third actuation element, through the movement mechanism, in a second direction when the pedal is released, wherein movement of the second actuation element in the second direction causes the lower clamping hatch to move from the closed position to the open position.

15 10. Device according to claim 9, wherein the first actuation element further comprises a first disengagement portion and the movement mechanism comprises a second disengagement portion, wherein the first disengagement portion is configured to engage with the second disengagement portion when the movement mechanism is in the second position and the pedal is released, and wherein engagement of the first disengagement 20 portion and the second disengagement portion moves the movement mechanism to the first position.

11. Device according to any of the preceding claims, wherein the upper clamping hatch and/or the lower clamping hatch comprise: 25 a first hatch part and a second hatch part, wherein, in the closed position, the first and second hatch parts abut each other, so as to be able to clamp the trash bag therebetween, and, in the open position, the first and second hatch parts are moved apart from each other.

30 12. Device according to claim 11, wherein the first and second hatch parts are each a spherical shell wedge, pivotable about a common pivot axis, wherein both end points of each wedge are positioned on the common pivot axis, preferably wherein each spherical shell wedge is identical.

35 13. Device according to claim 11 or 12, wherein at least part of an abutment surface of the first hatch part and/or the second hatch part is covered by a resilient sealing material,

such as an elastomer, the abutment surface being a contact surface between the first and second hatch parts in the closed position.

14. Device according to any of the preceding claims, wherein the upper clamping hatch and/or the lower clamping hatch are configured to clamp the trash bag, in the closed position, with sufficient force to clamp the trash bag in an airtight manner.
15. Device according to claim 14, wherein, the lower clamping hatch is further configured to clamp the trash bag, in the closed position, with a force that still allows the trash bag to slide through the lower clamping hatch whilst maintaining an airtight seal.
16. Device according to any of the preceding claims, wherein the mounting means of the upper clamping hatch are placed on an exterior surface of the upper clamping hatch.
17. Method for maintaining an airtight seal of a trash bag during insertion of a soiled object, such as a diaper, in the trash bag, using the device of any one of claims 1 – 16, comprising the steps of:
- clamping the trash bag closed, in an airtight manner, at a first location near an open end of the trash bag, and simultaneously clamping the trash bag closed, in an airtight manner, at a second location away from the open end of the trash bag and the first location;
 - subsequently releasing the clamp at the first location, and inserting the soiled object in the trash bag between the first and second locations;
 - after inserting the soiled object in the trash bag between the first and second locations, re-establishing the clamp at the first location and subsequently releasing the clamp at the second location, such that the soiled object is inserted in the trash bag whilst maintaining the airtight seal of the trash bag to the exterior of the trash bag,
 - wherein clamping the trash bag at the first location is effected by the upper clamping hatch and clamping the trash bag at the second location is effected by the lower clamping hatch.
18. Method of claim 17, wherein an edge of the trash bag, defining its open end, is attached to the upper clamping hatch at an external portion thereof.

19. Method of claim 18, wherein the edge of the trash bag is attached to the upper clamping hatch by means of the mounting means.

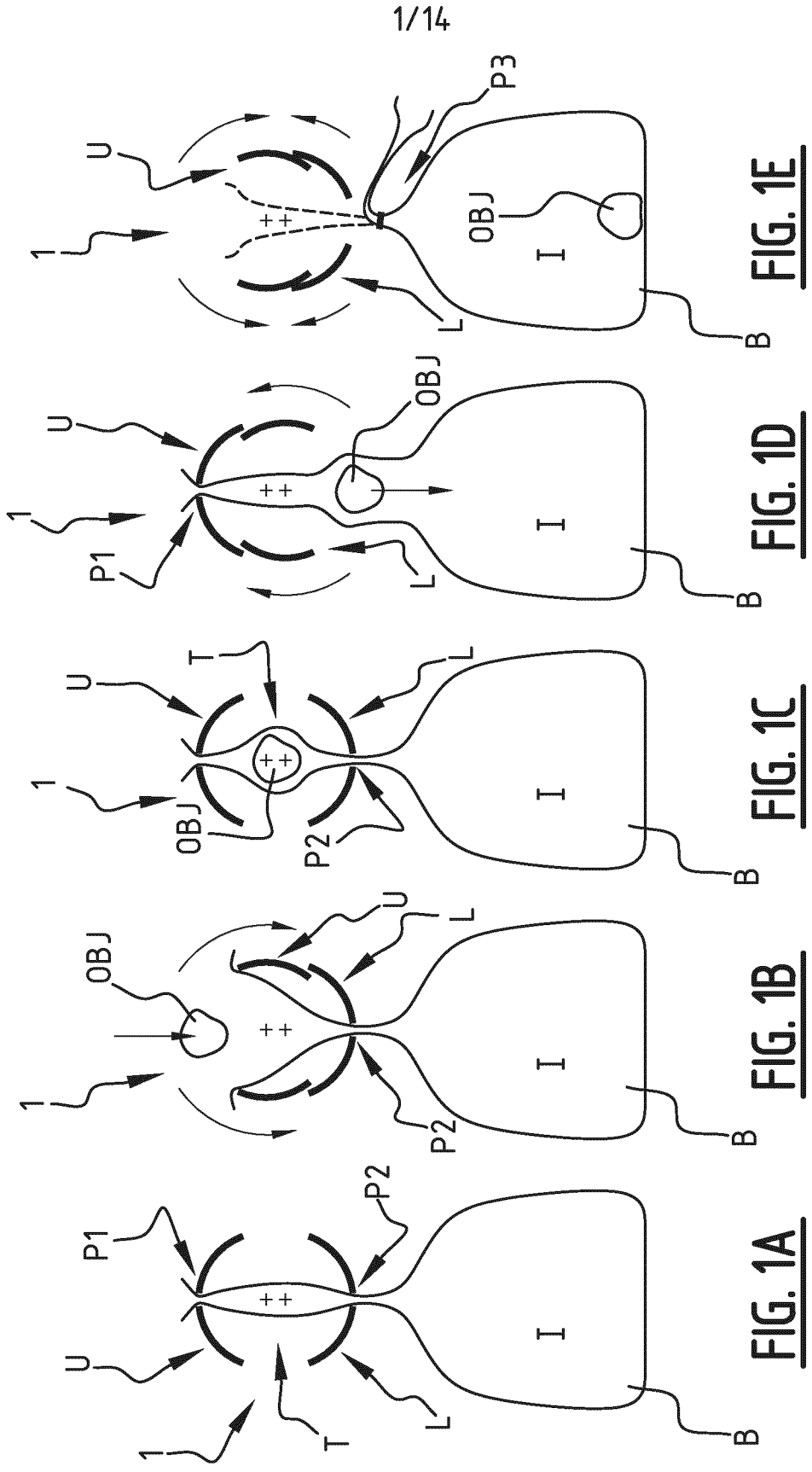

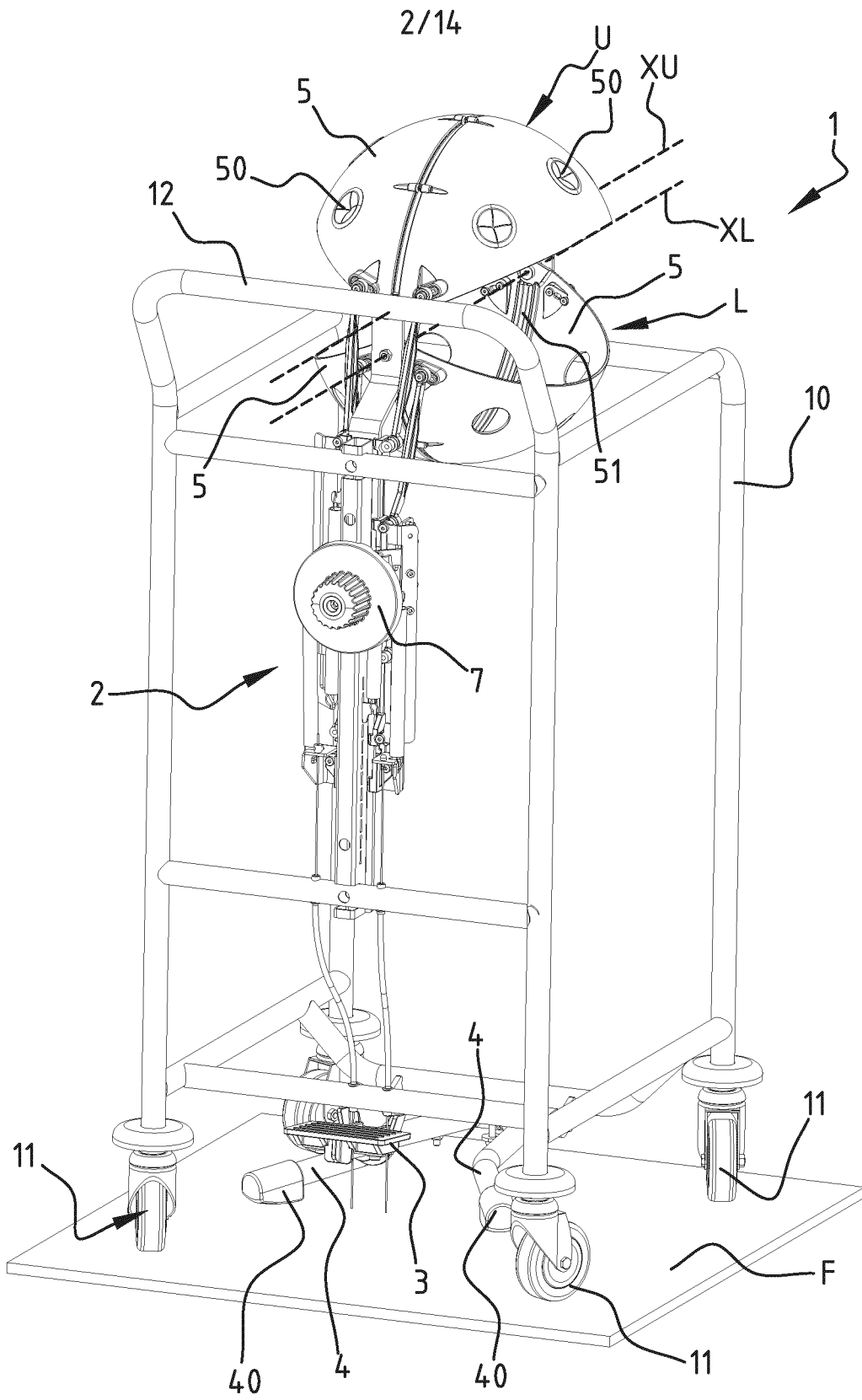

FIG. 2

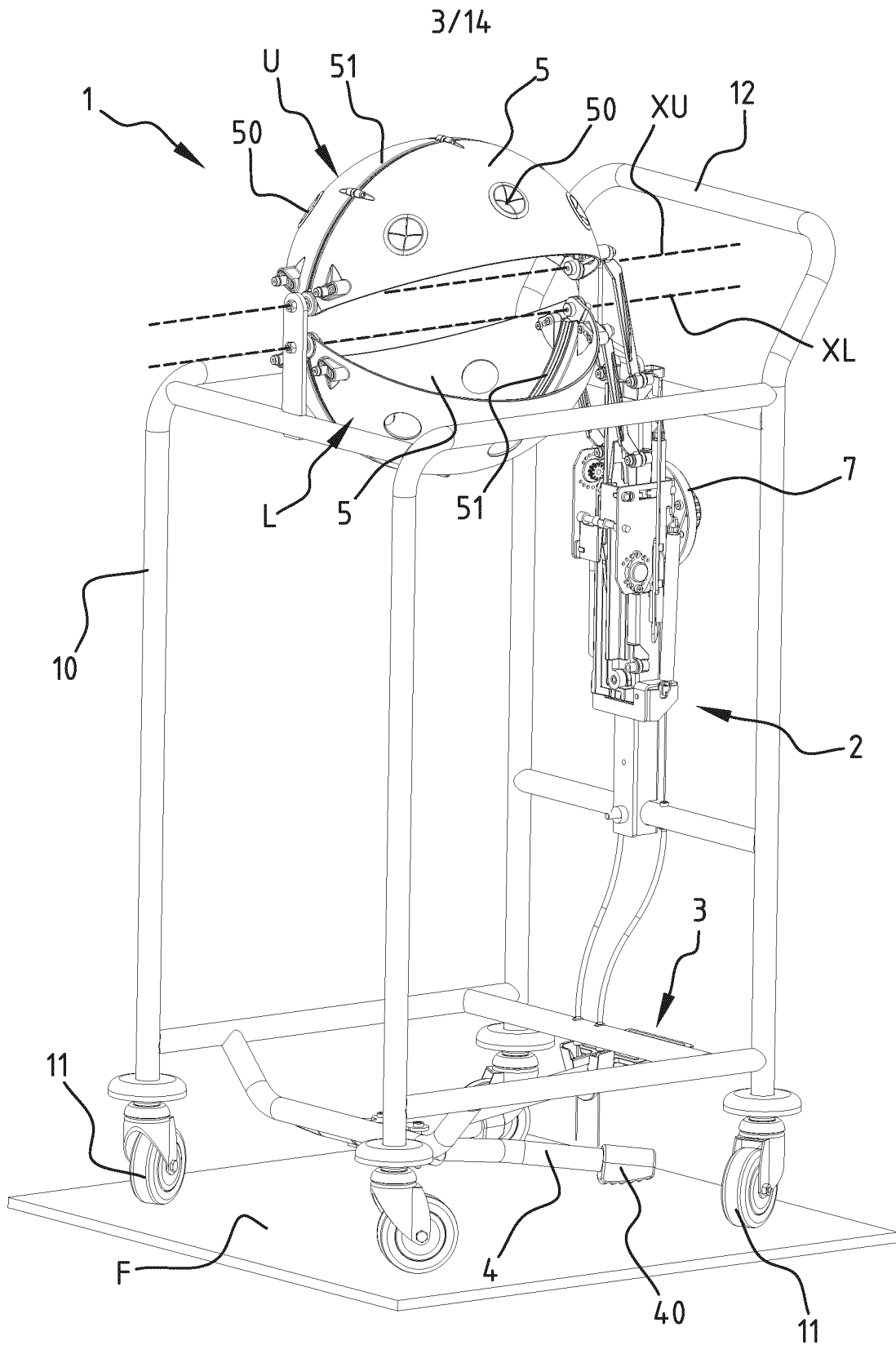

FIG. 3

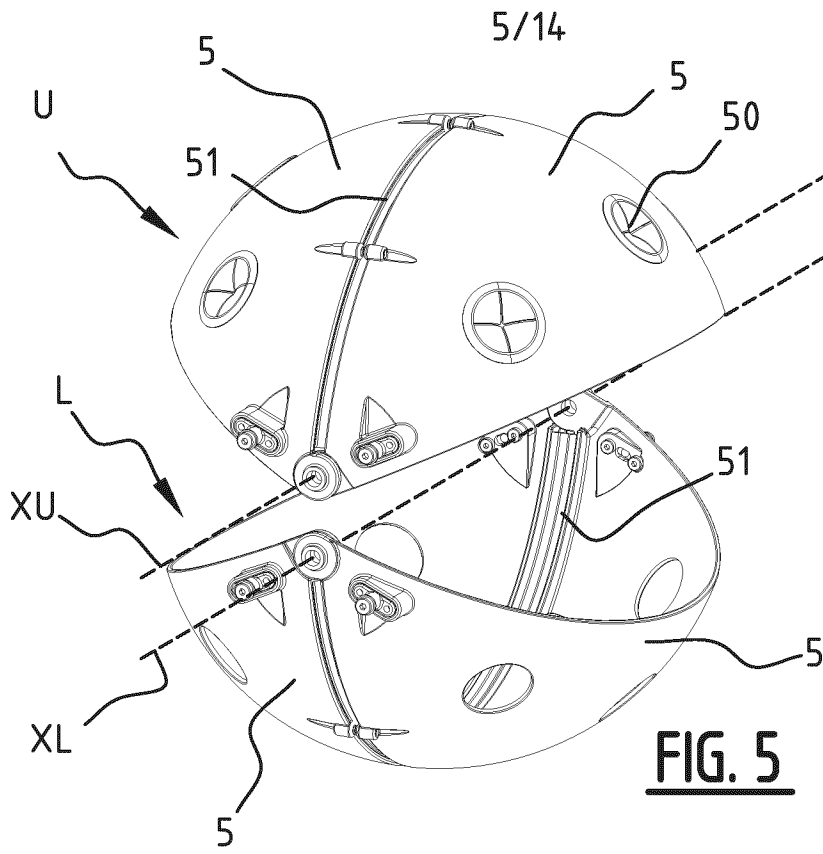

FIG. 5

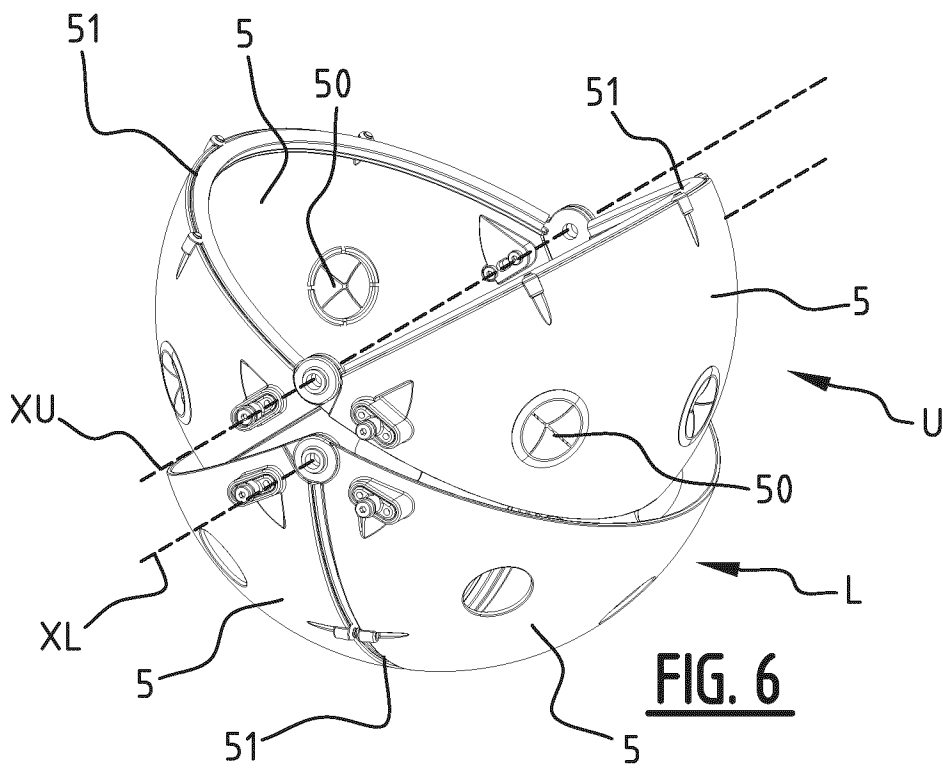

FIG. 6

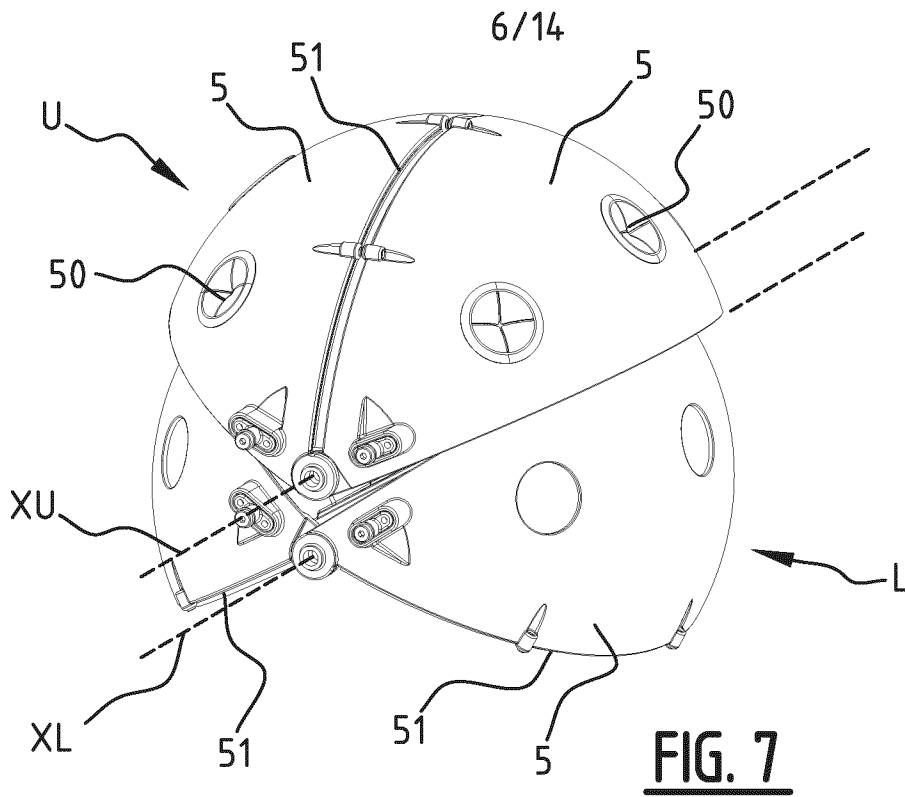

FIG. 7

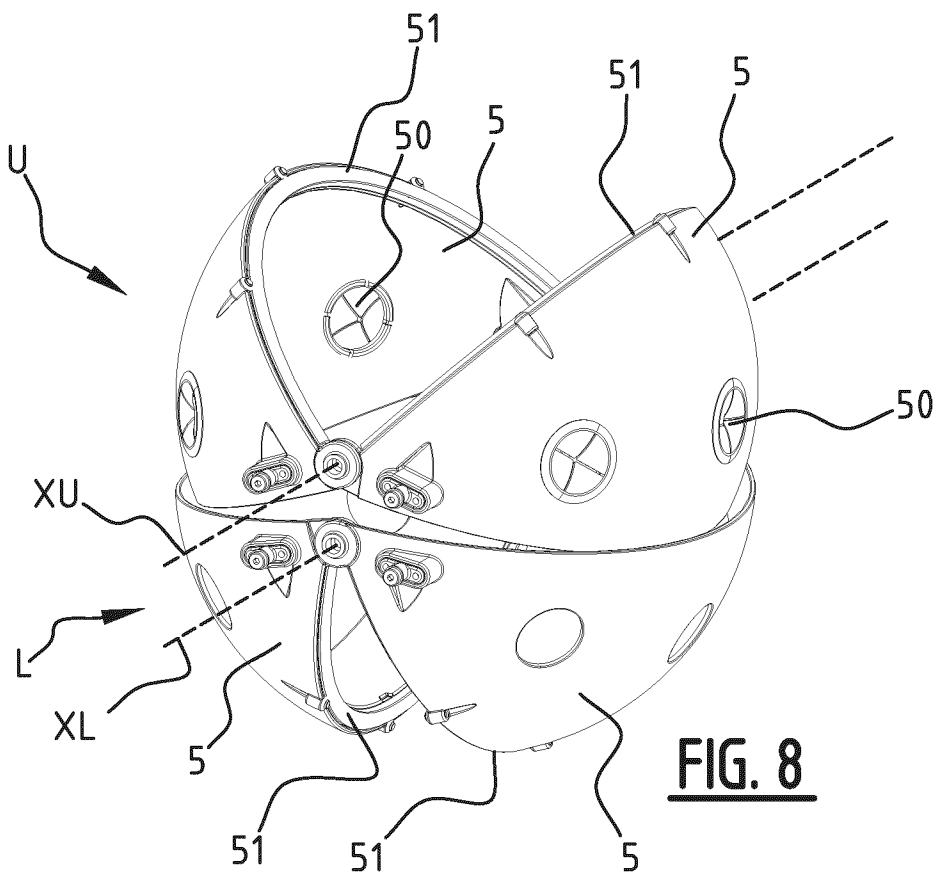

FIG. 8

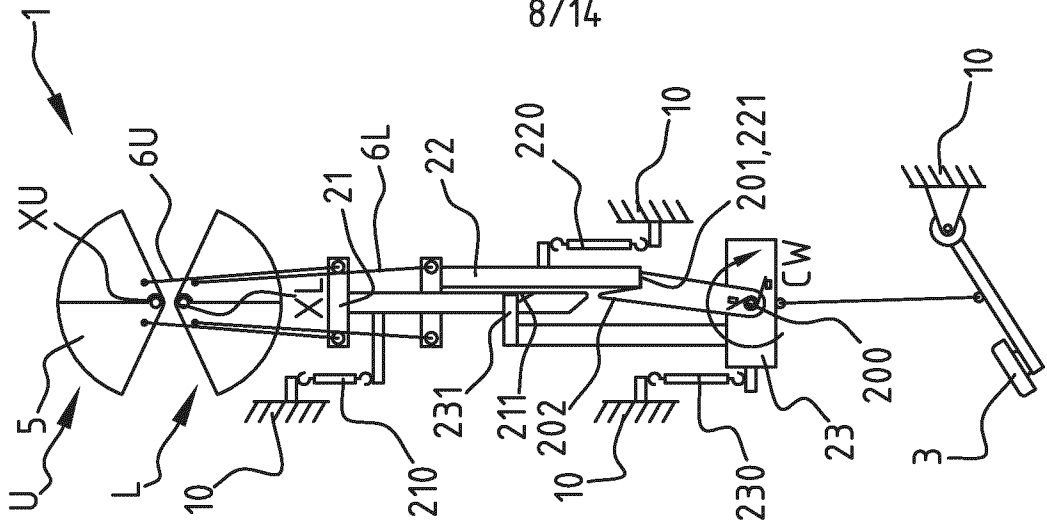

FIG. 11A

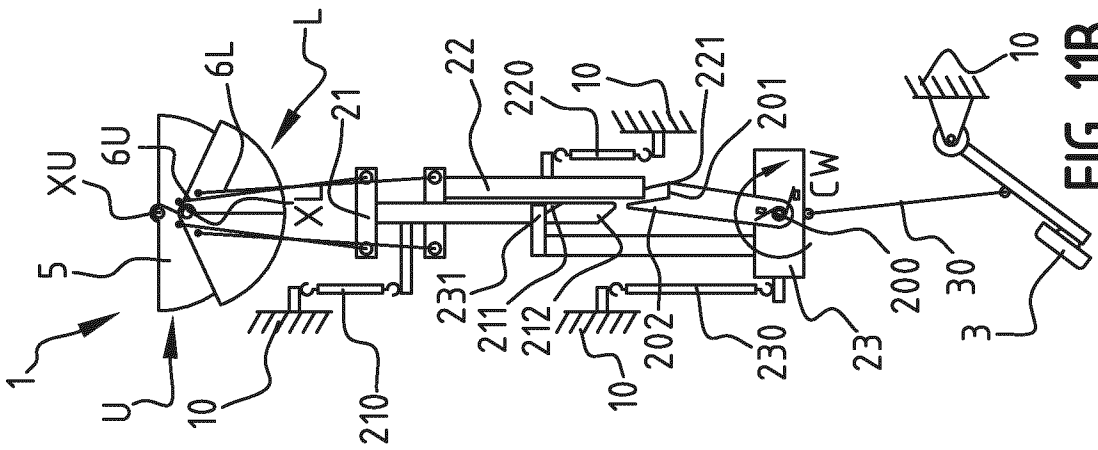

FIG. 11B

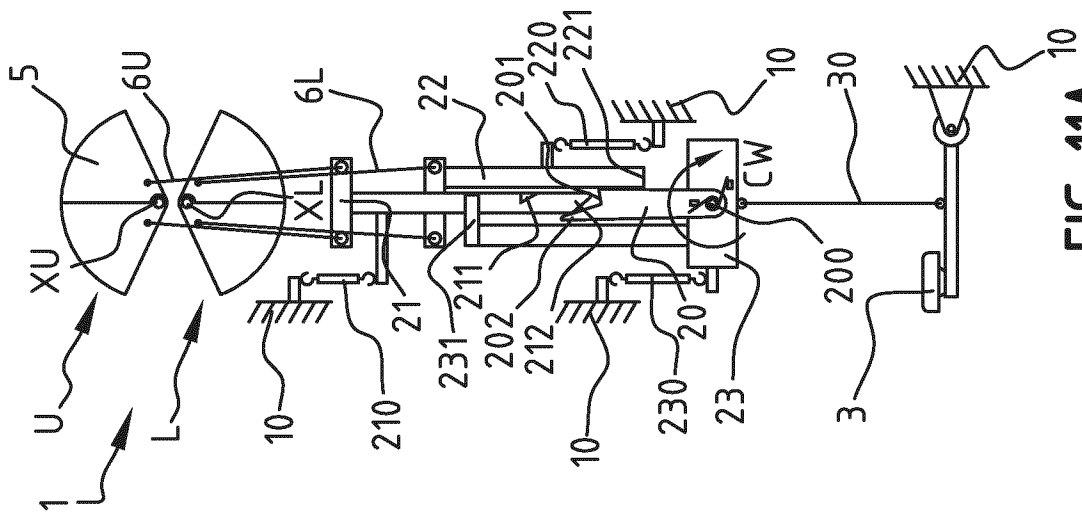

FIG. 11C

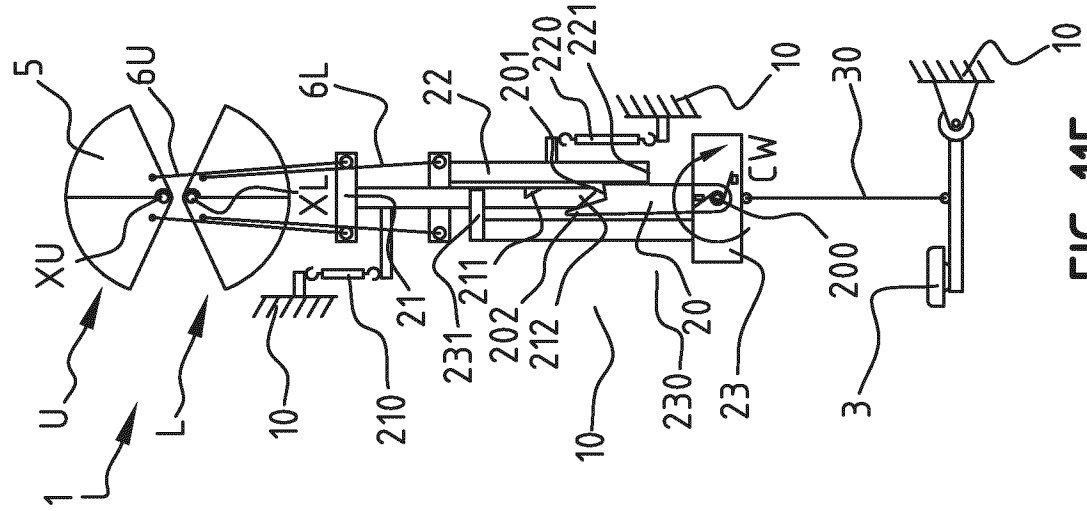

FIG. 11D

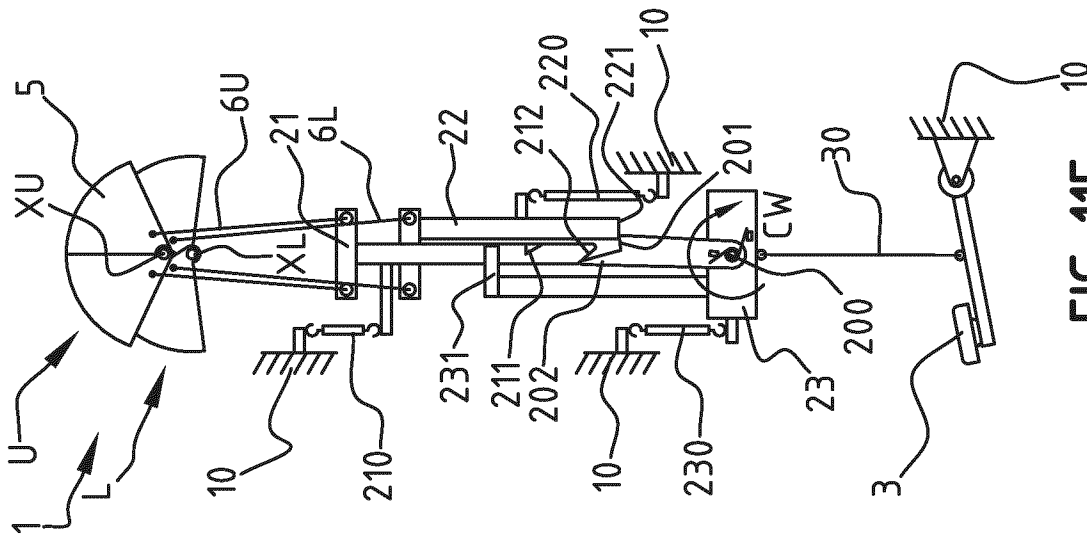

FIG. 11E

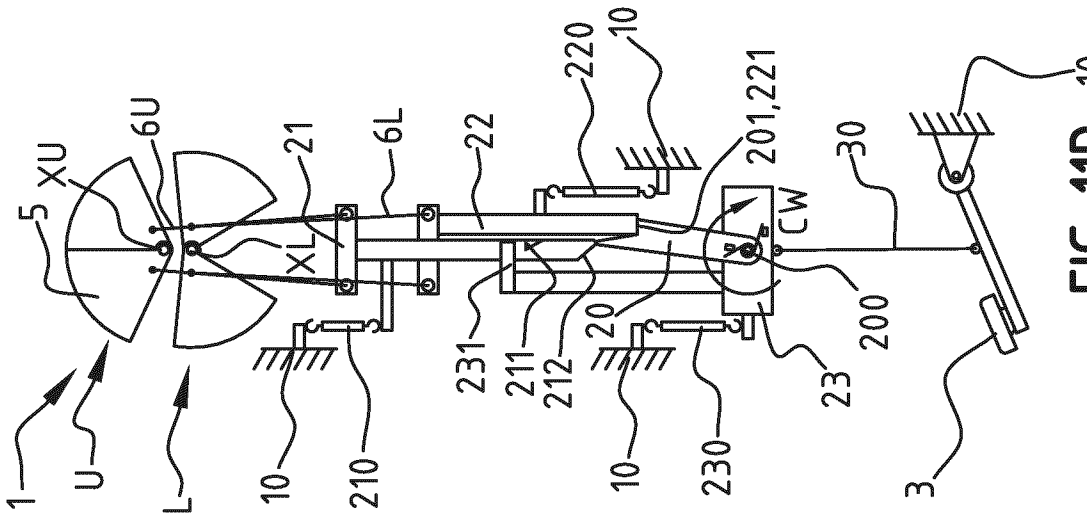

FIG. 11F

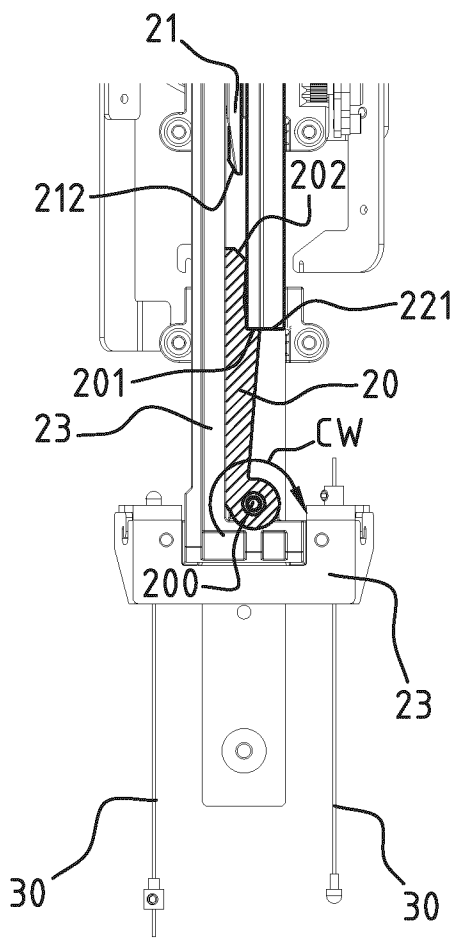

FIG. 12

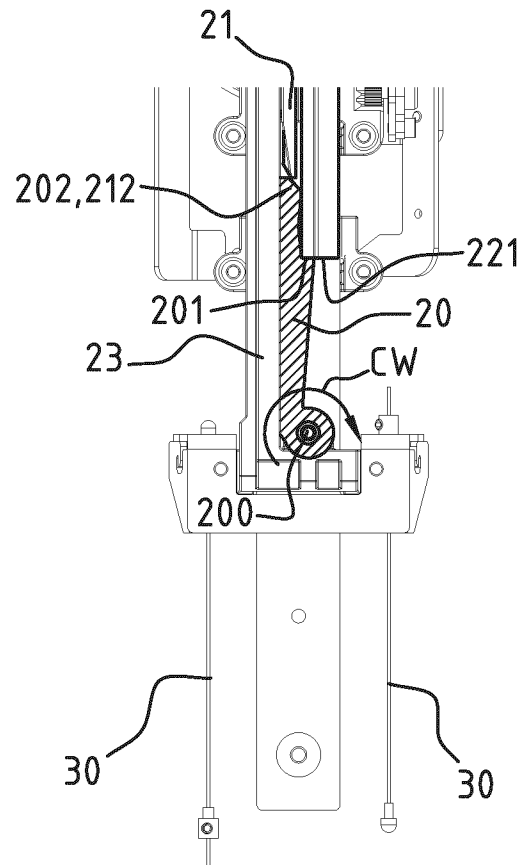

FIG. 13

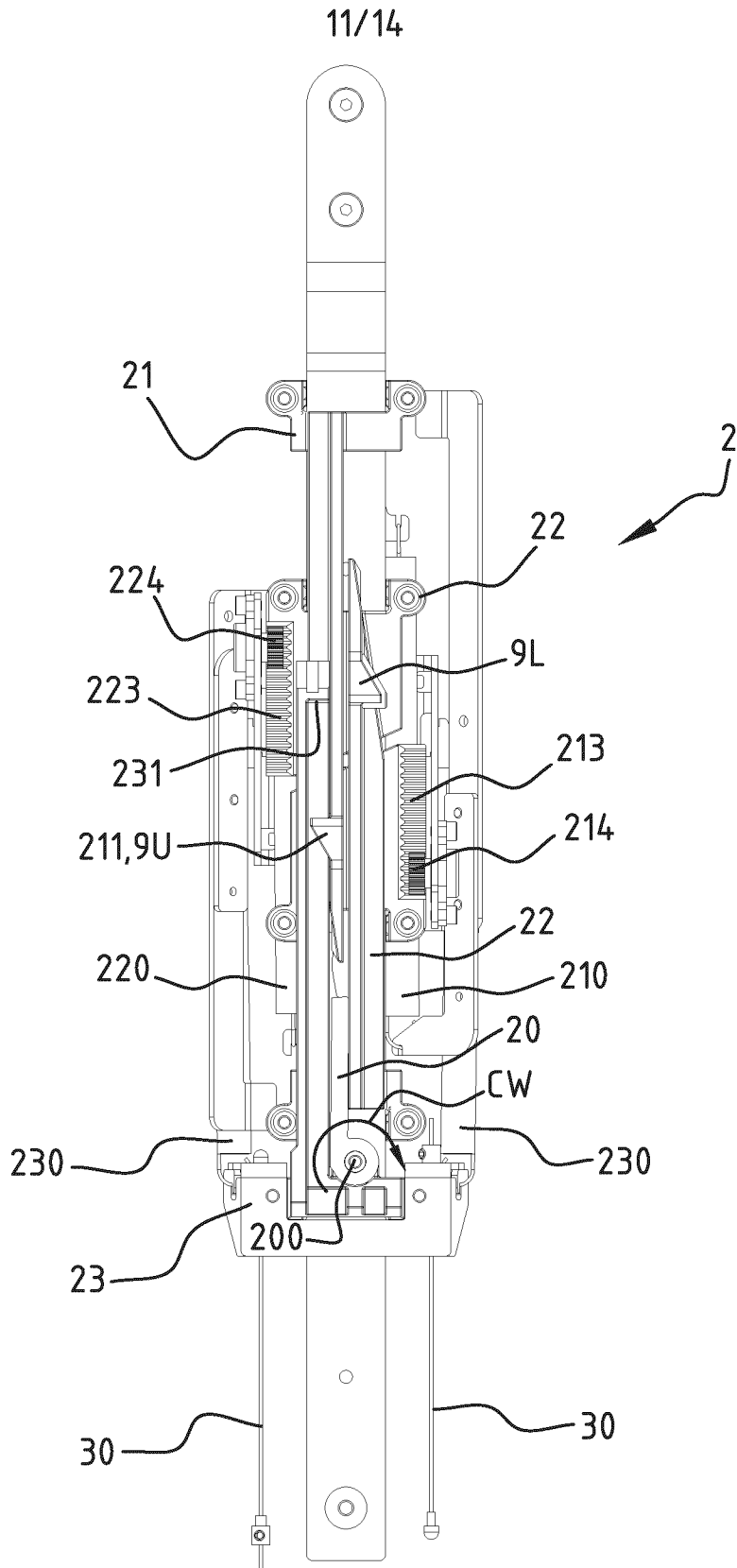

FIG. 14

12/14

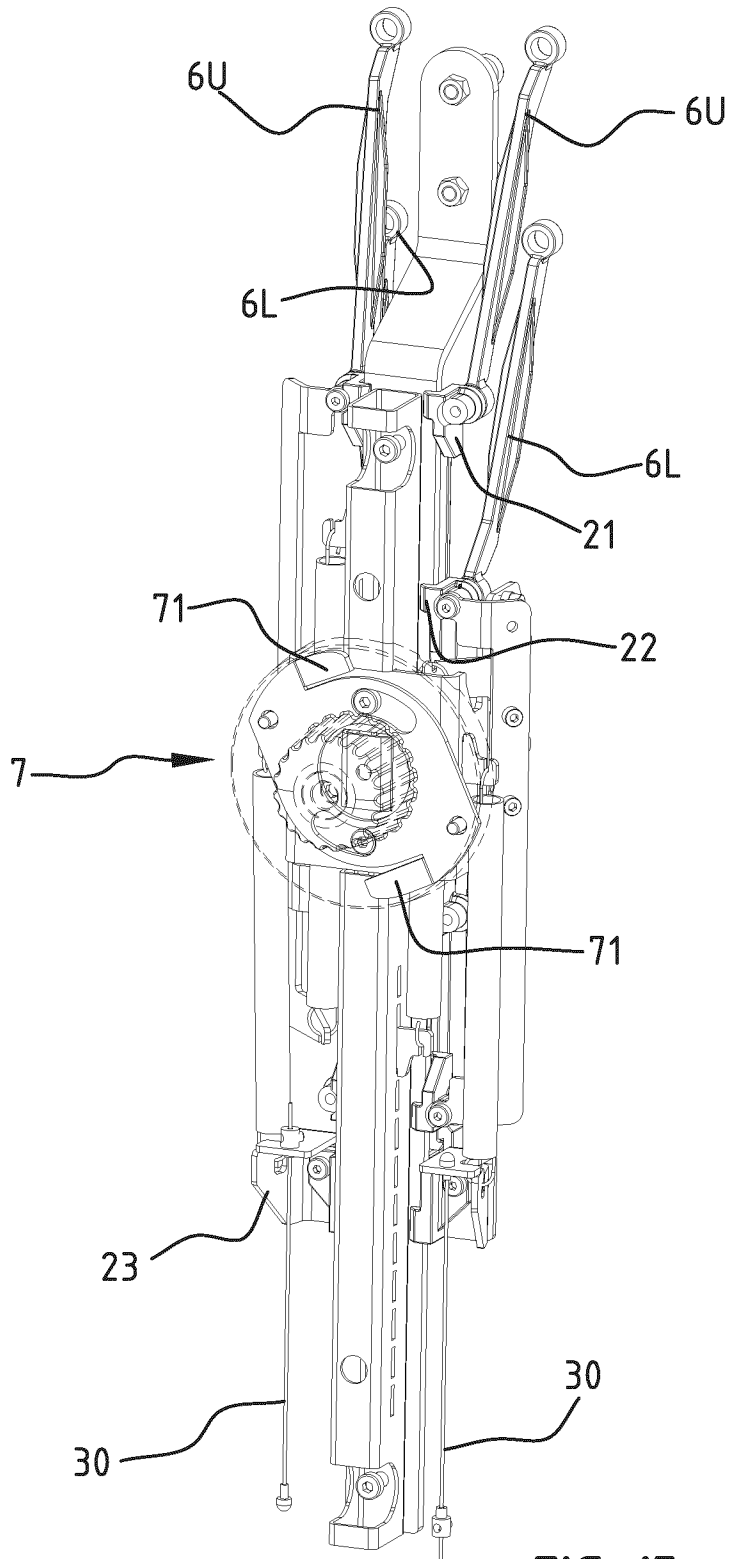

FIG. 15

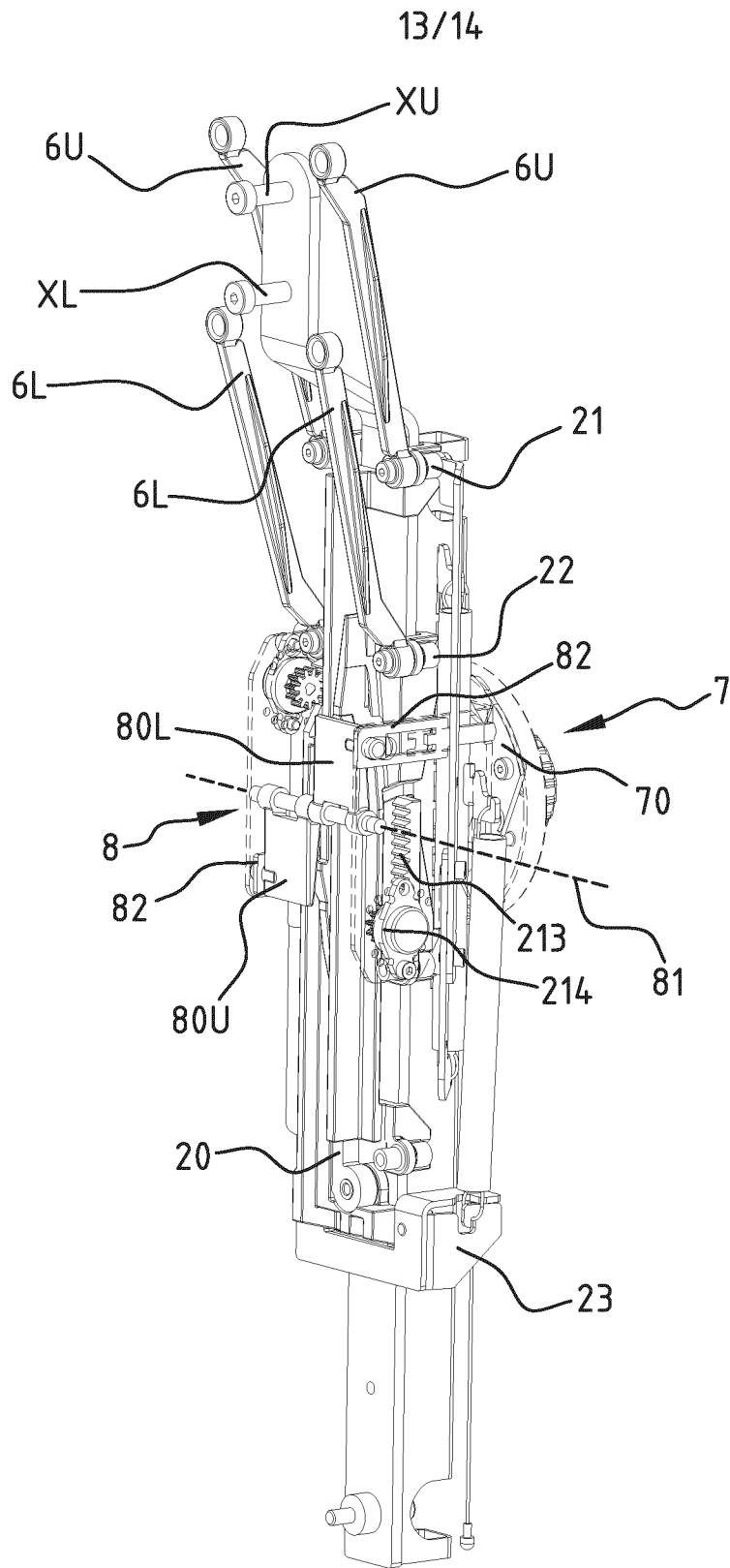

FIG. 16

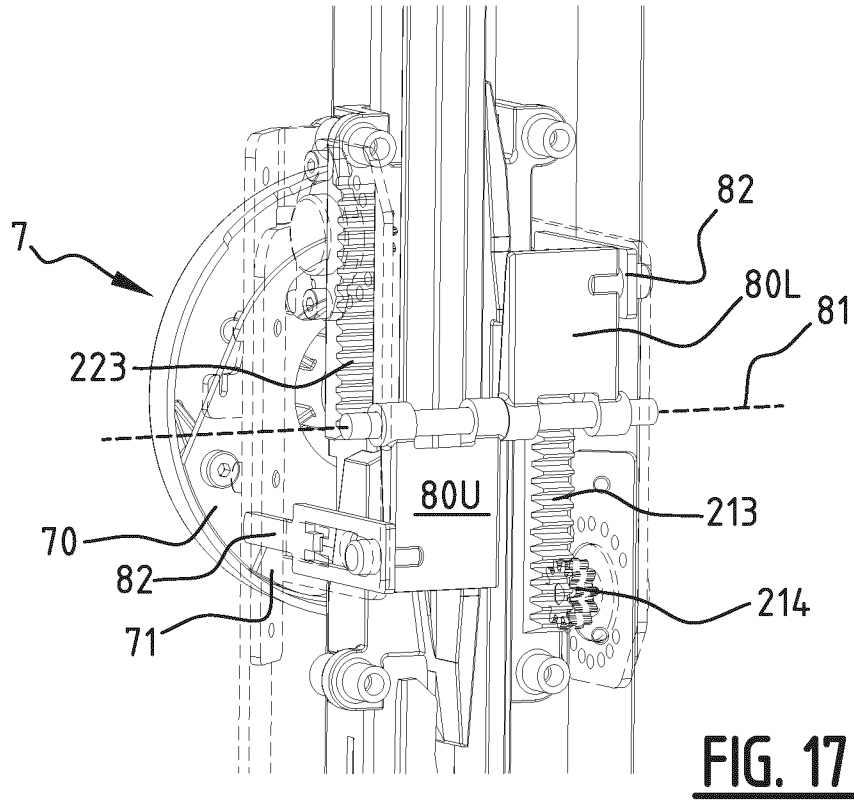

FIG. 17

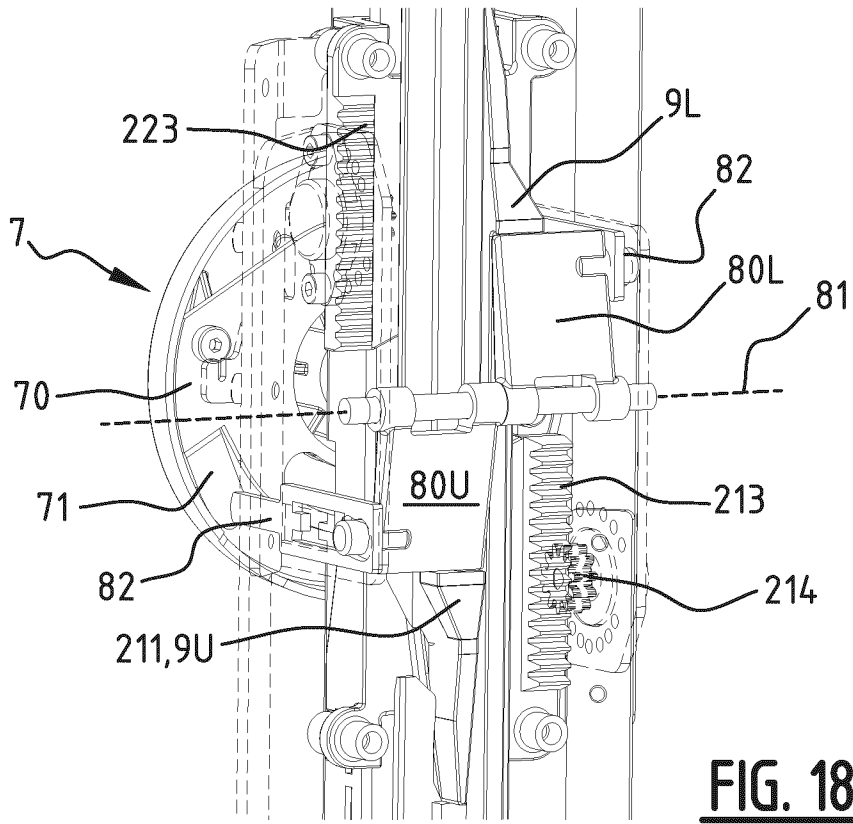

FIG. 18

INTERNATIONAL SEARCH REPORT

International application No PCT/EP2024/087649

A. CLASSIFICATION OF SUBJECT MATTER
 INV. B65F1/06 B65F1/10 B65F1/16
 ADD.

According to International Patent Classification (IPC) or to both national classification and IPC

B. FIELDS SEARCHED

Minimum documentation searched (classification system followed by classification symbols)
B65F

Documentation searched other than minimum documentation to the extent that such documents are included in the fields searched

Electronic data base consulted during the international search (name of data base and, where practicable, search terms used)
EPO- Internal

C. DOCUMENTS CONSIDERED TO BE RELEVANT

Category*	Citation of document, with indication, where appropriate, of the relevant passages	Relevant to claim No.
A	WO 96/06788 A1 (JONES JONES & JONES COMPANY N [NL]) 7 March 1996 (1996-03-07) figures 15-23 page 13, line 5 - page 14, line 3 -----	1 - 19
A	JP H08 282801 A (MATSUSHITA ELECTRIC IND CO LTD) 29 October 1996 (1996-10-29) figures 1-4 -----	1 - 19

Further documents are listed in the continuation of Box C. See patent family annex.

* Special categories of cited documents :

<p>"A" document defining the general state of the art which is not considered to be of particular relevance</p> <p>"E" earlier application or patent but published on or after the international filing date</p> <p>"L" document which may throw doubts on priority claim(s) or which is cited to establish the publication date of another citation or other special reason (as specified)</p> <p>"O" document referring to an oral disclosure, use, exhibition or other means</p> <p>"P" document published prior to the international filing date but later than the priority date claimed</p>	<p>"T" later document published after the international filing date or priority date and not in conflict with the application but cited to understand the principle or theory underlying the invention</p> <p>"X" document of particular relevance; the claimed invention cannot be considered novel or cannot be considered to involve an inventive step when the document is taken alone</p> <p>"Y" document of particular relevance; the claimed invention cannot be considered to involve an inventive step when the document is combined with one or more other such documents, such combination being obvious to a person skilled in the art</p> <p>"&" document member of the same patent family</p>
---	---

Date of the actual completion of the international search 23 January 2025	Date of mailing of the international search report 10/02/2025
---	---

Name and mailing address of the ISA/ European Patent Office, P.B. 5818 Patentlaan 2 NL - 2280 HV Rijswijk Tel. (+31-70) 340-2040, Fax: (+31-70) 340-3016	Authorized officer Pardo Torre, Ignacio
--	---

INTERNATIONAL SEARCH REPORT

Information on patent family members

International application No

PCT/EP2024/087649

Patent document cited in search report	Publication date	Patent family member(s)	Publication date
WO 9606788	A1	07-03-1996	AT E179948 T1 15-05-1999
			AT E253511 T1 15-11-2003
			AU 3518795 A 22-03-1996
			DE 69509660 T2 02-12-1999
			DE 69532090 T2 09-09-2004
			EP 0776305 A1 04-06-1997
			EP 0915033 A2 12-05-1999
			ES 2136303 T3 16-11-1999
			ES 2207789 T3 01-06-2004
			US 5651231 A 29-07-1997
			WO 9606788 A1 07-03-1996

JP H08282801	A	29-10-1996	NONE
