



US 20030157308A1

(19) **United States**

(12) **Patent Application Publication**  
**McDonald**

(10) **Pub. No.: US 2003/0157308 A1**

(43) **Pub. Date: Aug. 21, 2003**

(54) **FOLDED SHEET PRODUCT**

(30) **Foreign Application Priority Data**

(76) Inventor: **George Wallace McDonald**, Guernsey  
(GB)

Jul. 6, 2000 (GB)..... 0016598.5  
Jul. 8, 2000 (GB)..... 0016763.5

Correspondence Address:

**SQUIRE, SANDERS & DEMPSEY L.L.P.**  
**14TH FLOOR**  
**8000 TOWERS CRESCENT**  
**TYSONS CORNER, VA 22182 (US)**

**Publication Classification**

(51) **Int. Cl.<sup>7</sup>** ..... **D03D 13/00**  
(52) **U.S. Cl.** ..... **428/222; 220/9.3**

(21) Appl. No.: **10/332,063**

(22) PCT Filed: **Jul. 6, 2001**

(86) PCT No.: **PCT/GB01/03097**

(57) **ABSTRACT**

The present invention discloses a folded sheet product comprising a folded sheet having a first set of folds and a blister strip attached to a segment of said sheet. A stiff portion may be provided at a corner segment of the sheet.

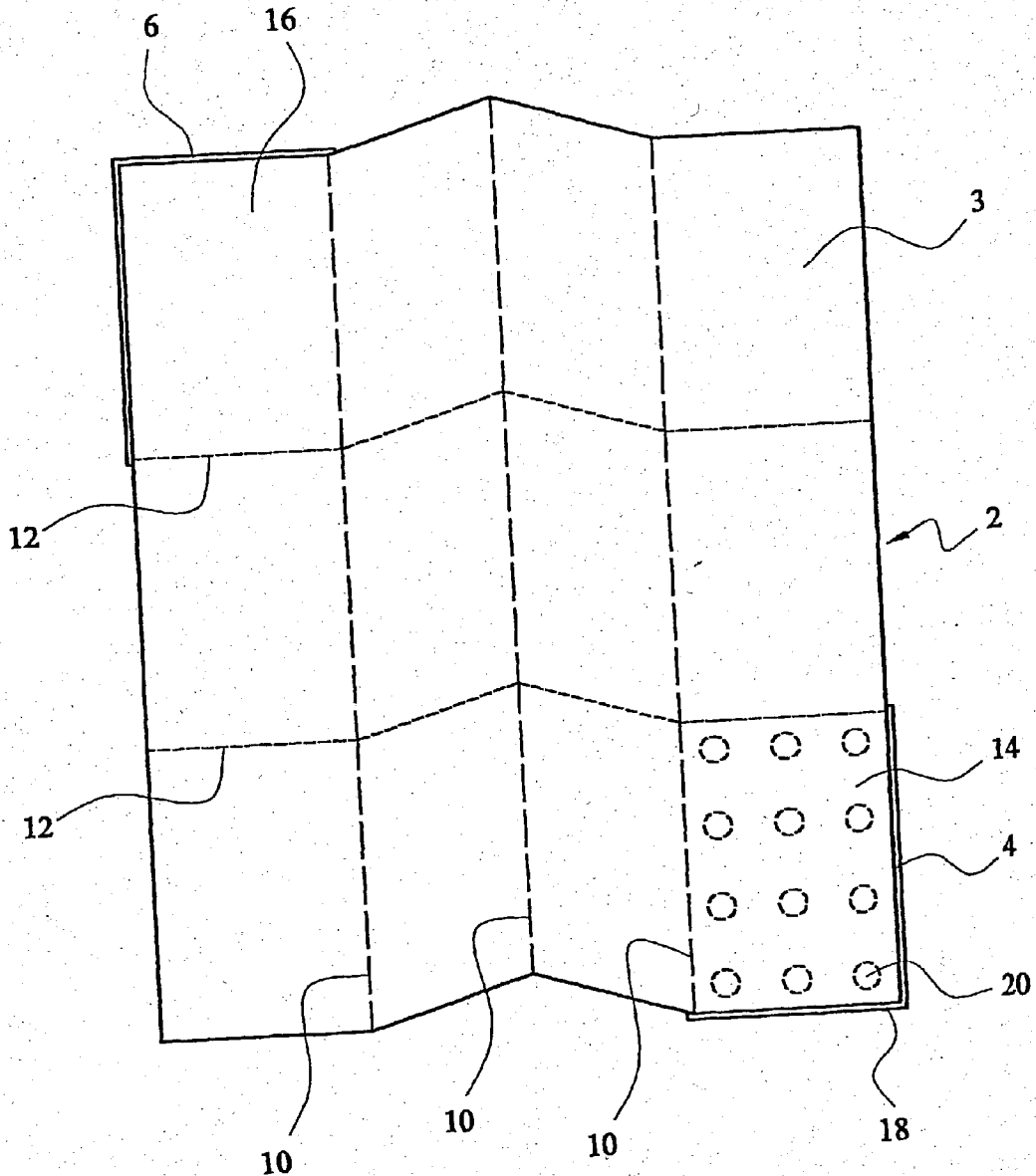

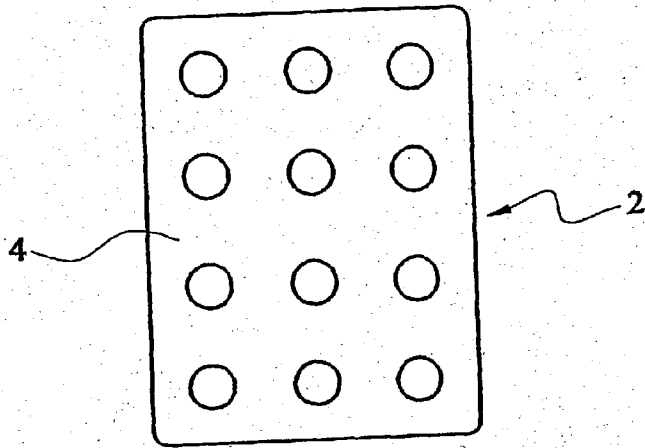

FIG. 1

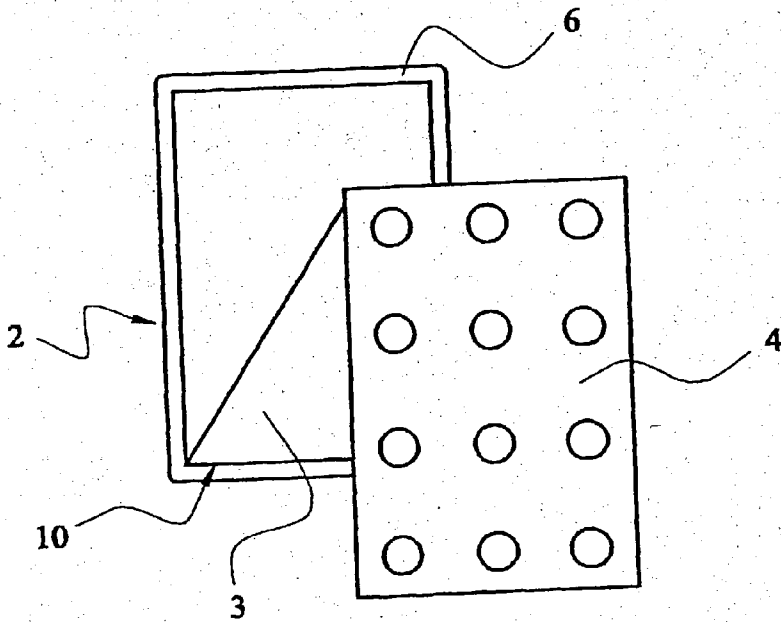

FIG. 2

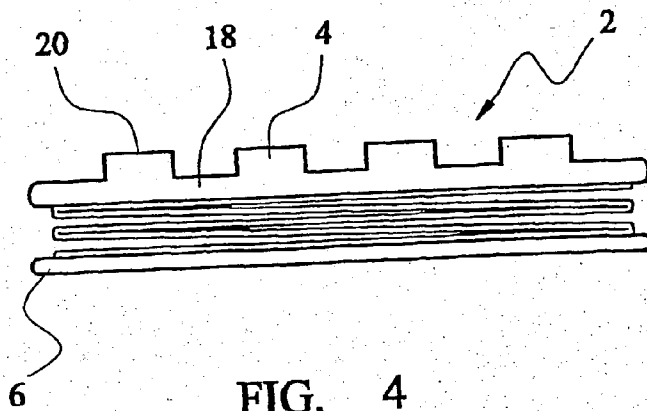

FIG. 4

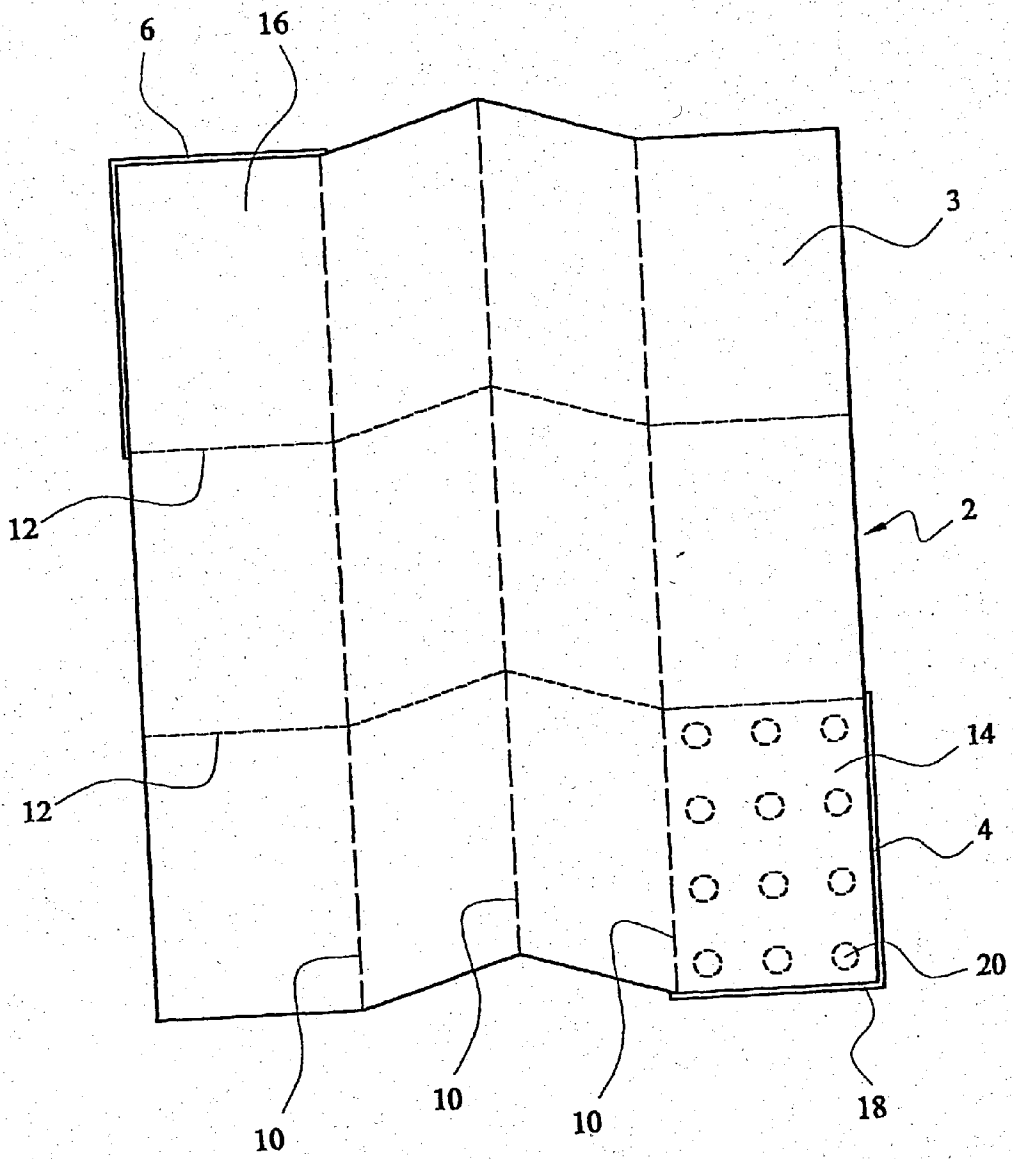

FIG. 4

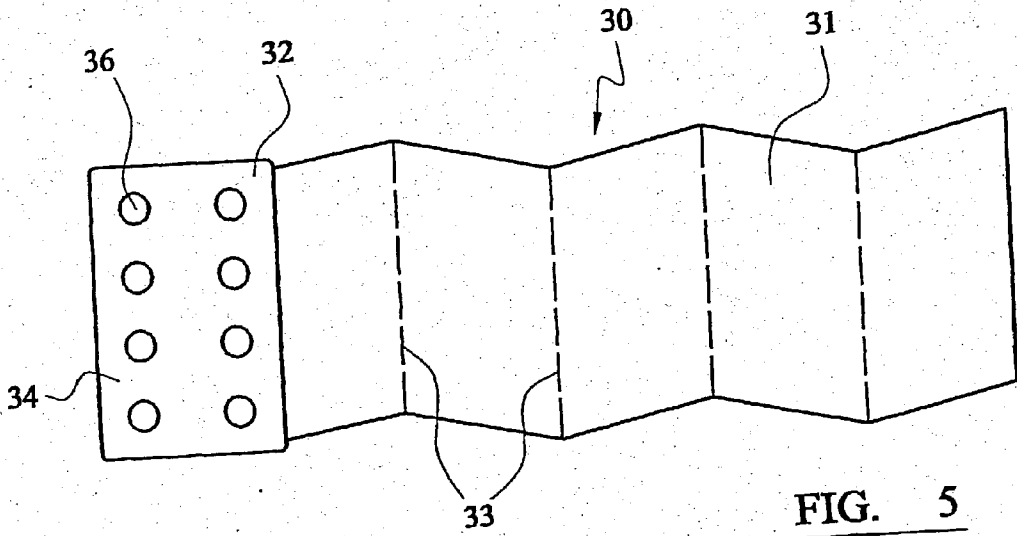

FIG. 5

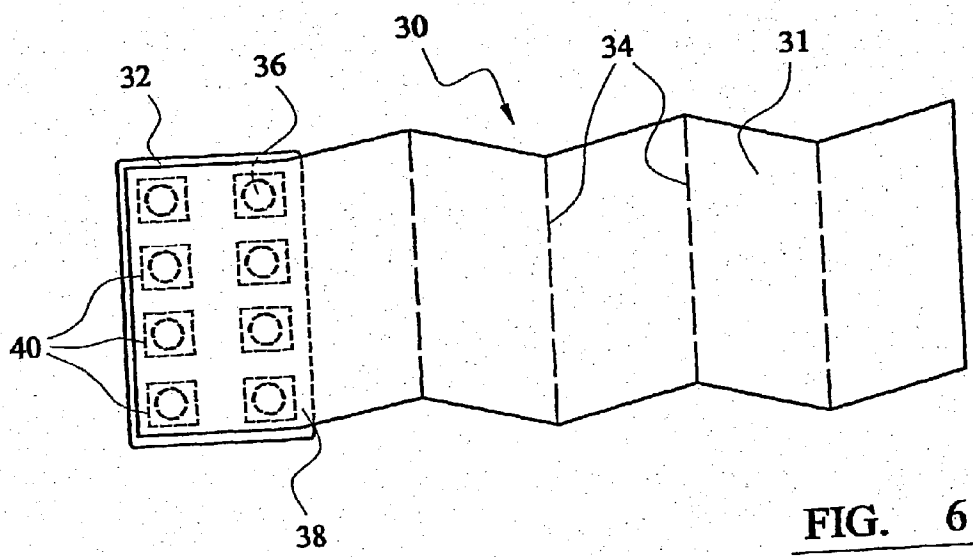

FIG. 6

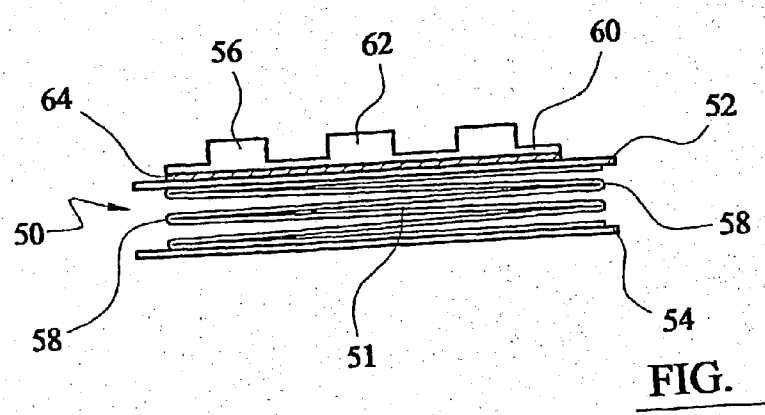

FIG. 7

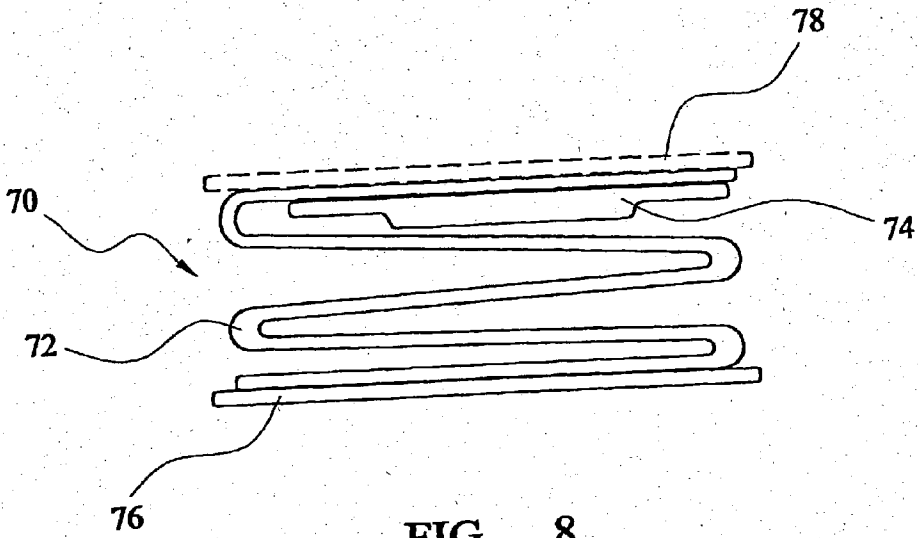

FIG. 8

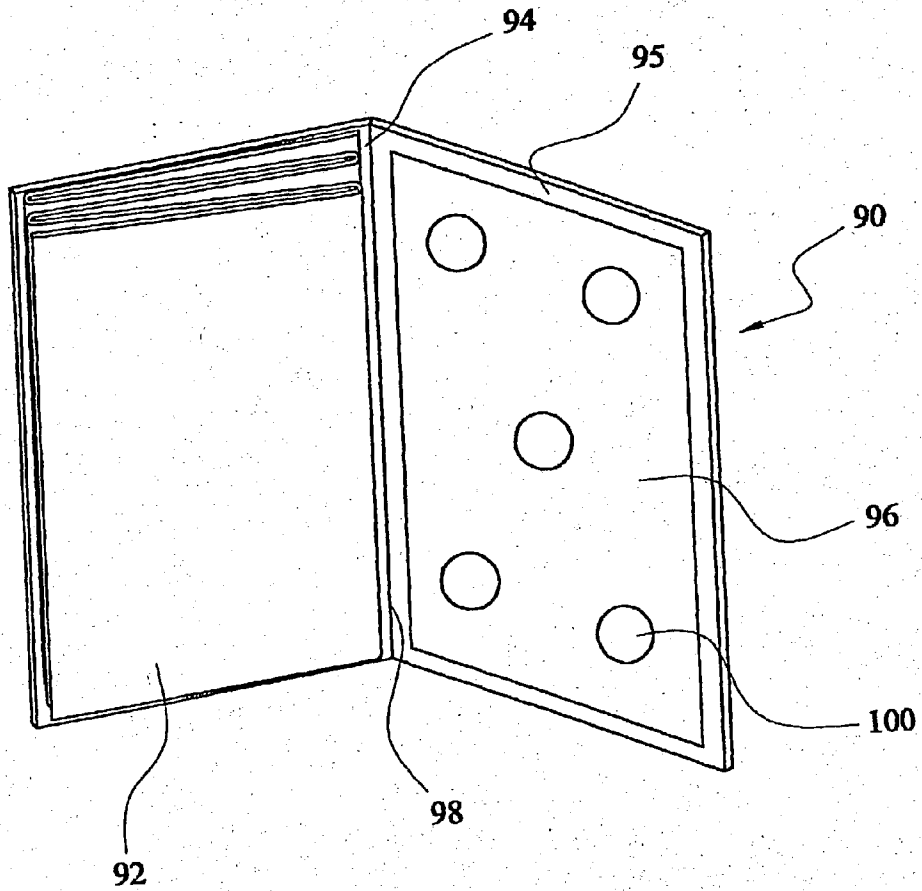

FIG. 9

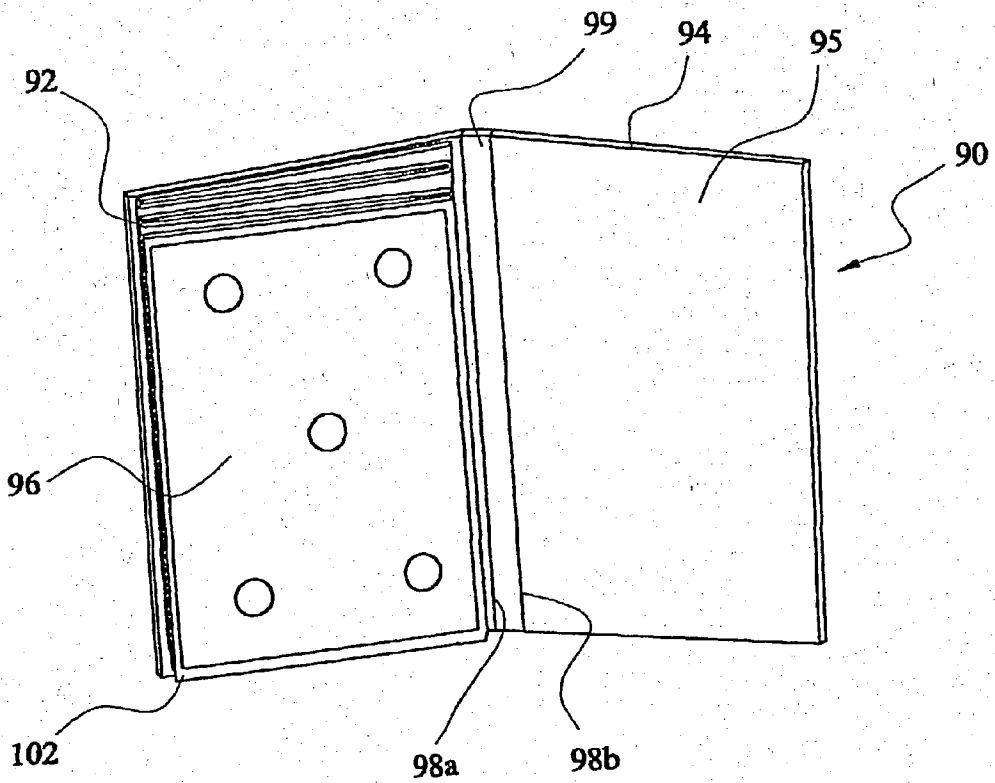

FIG. 10

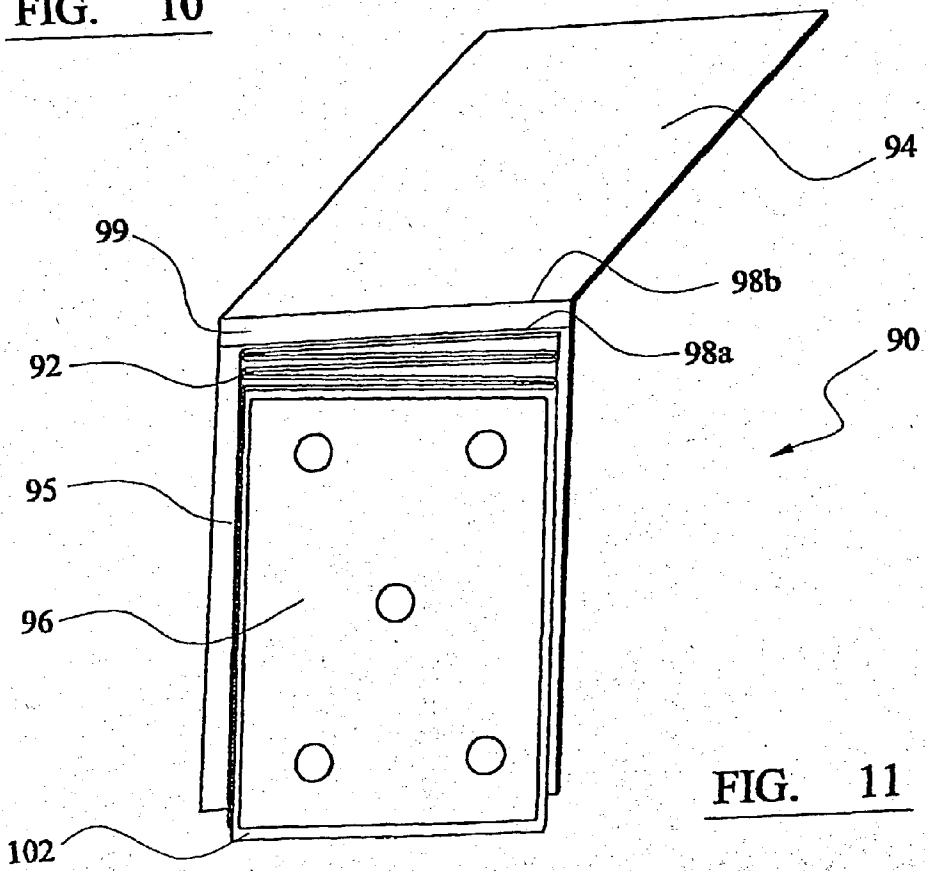

FIG. 11

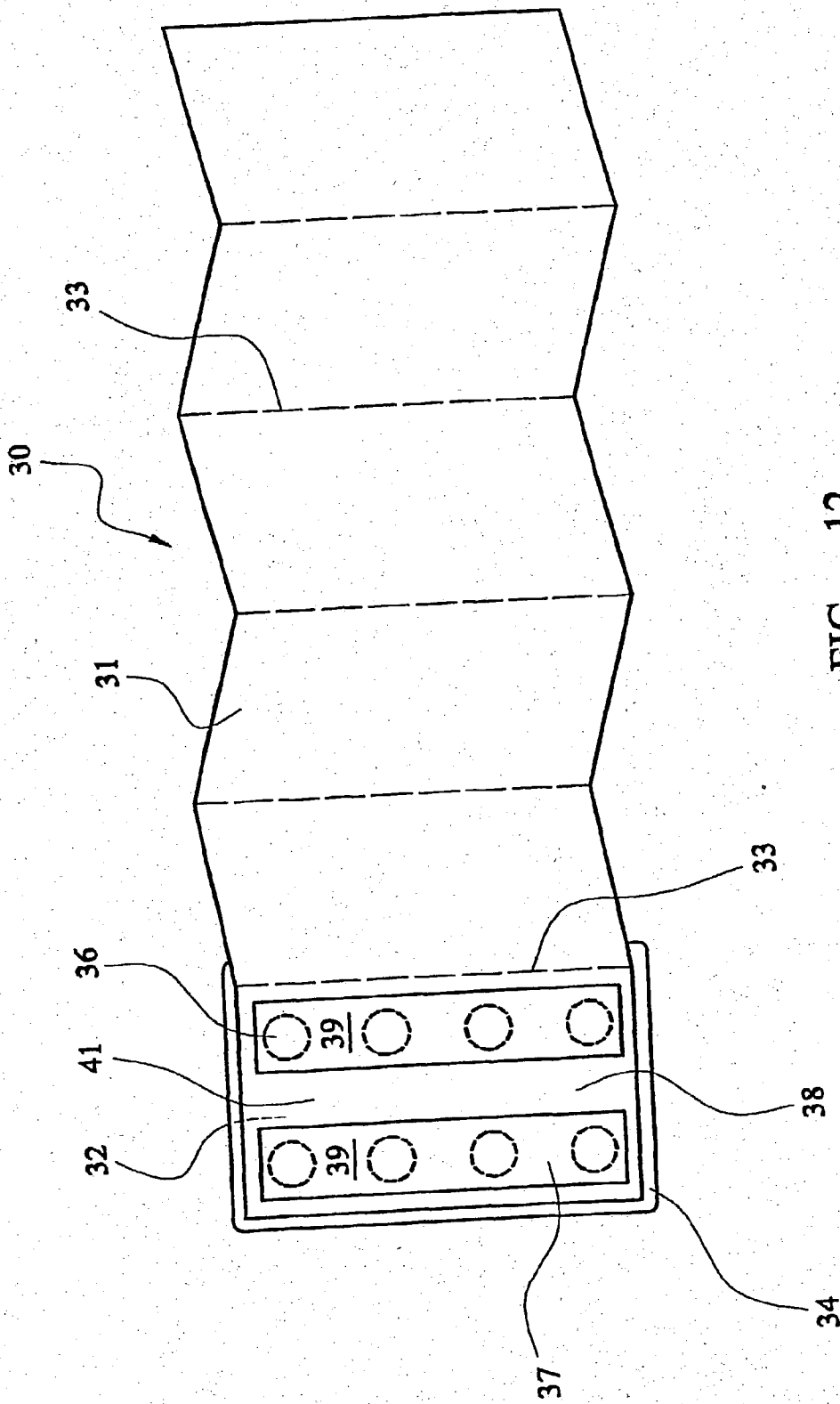
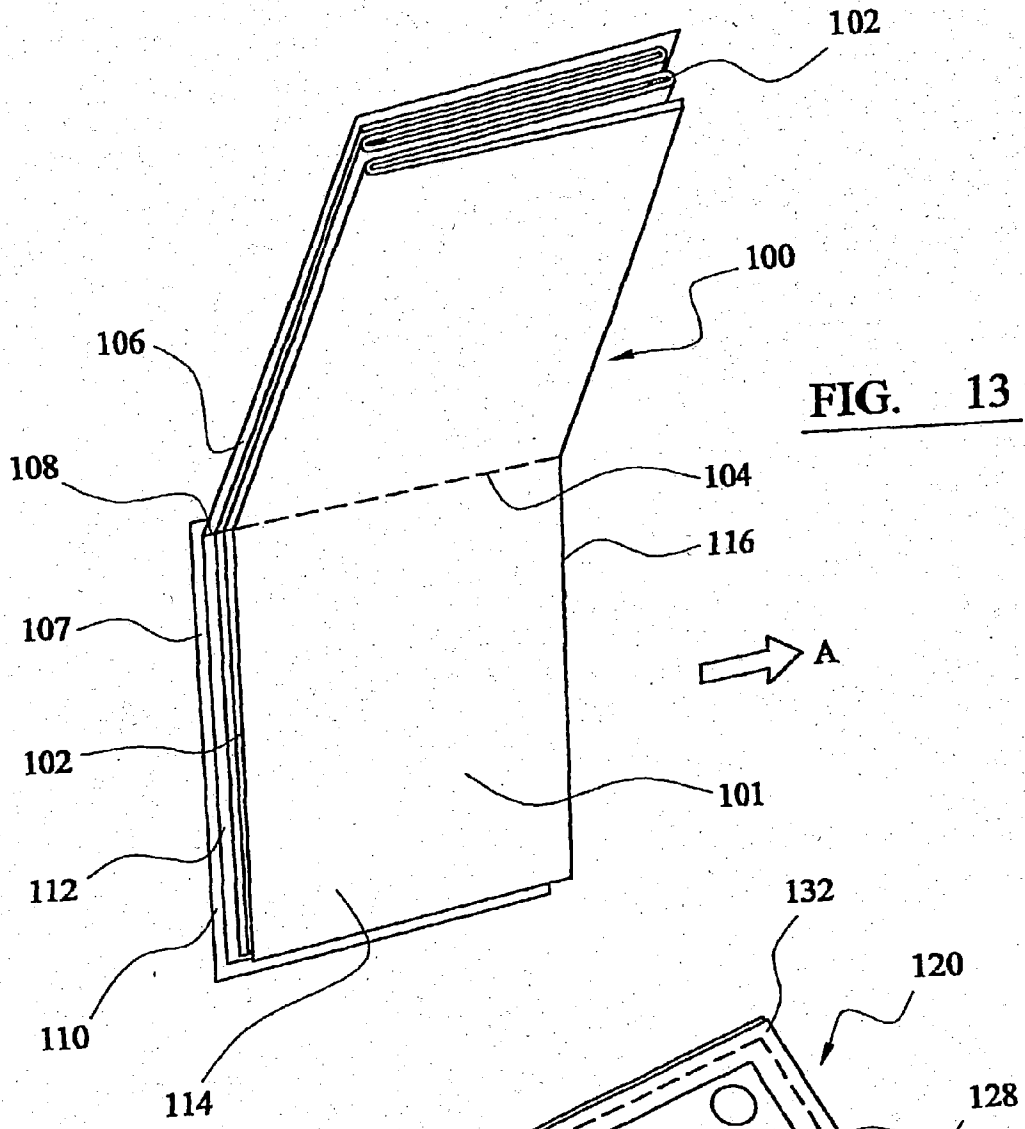
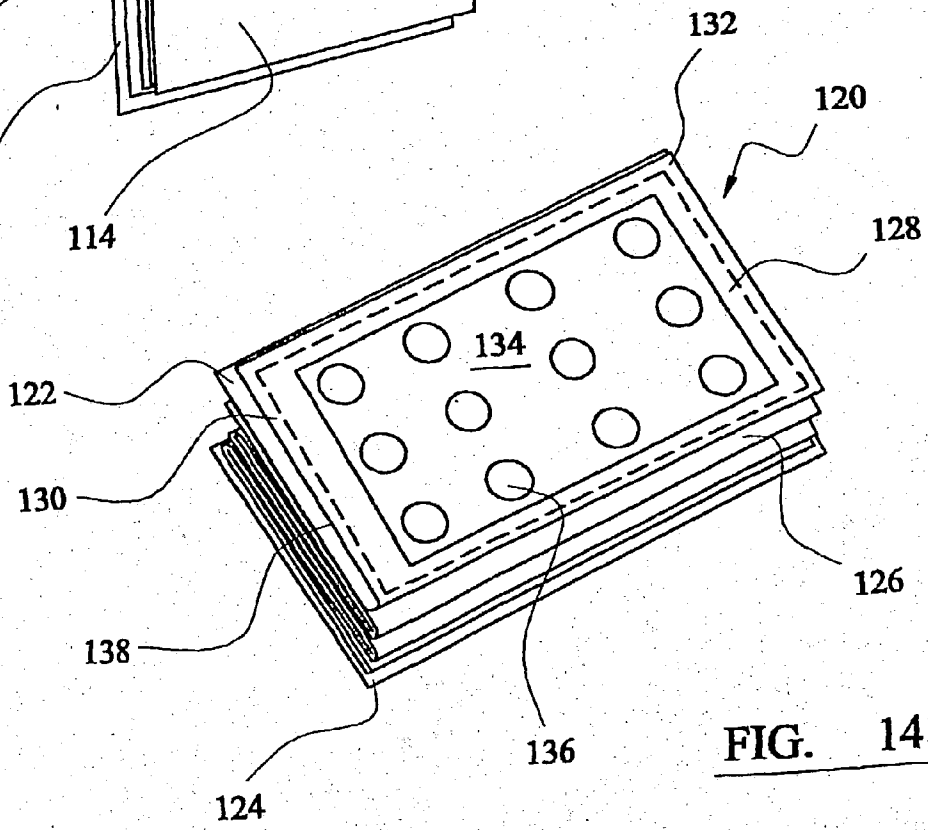

FIG. 12



**FIG. 13**



**FIG. 14**

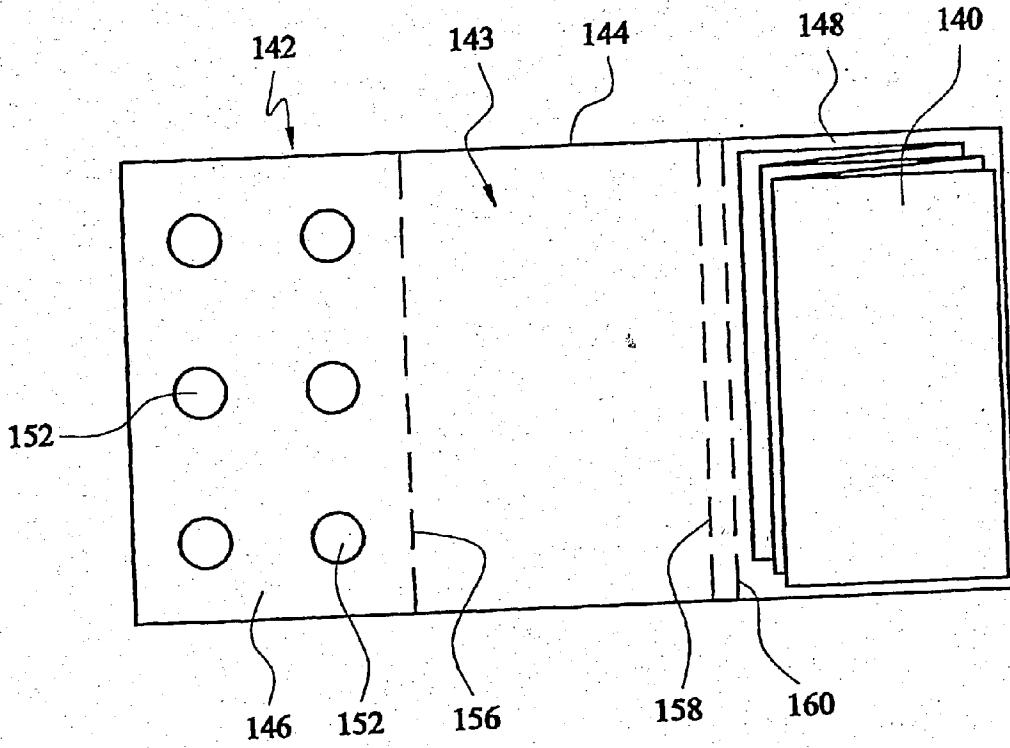

**FIG. 15**

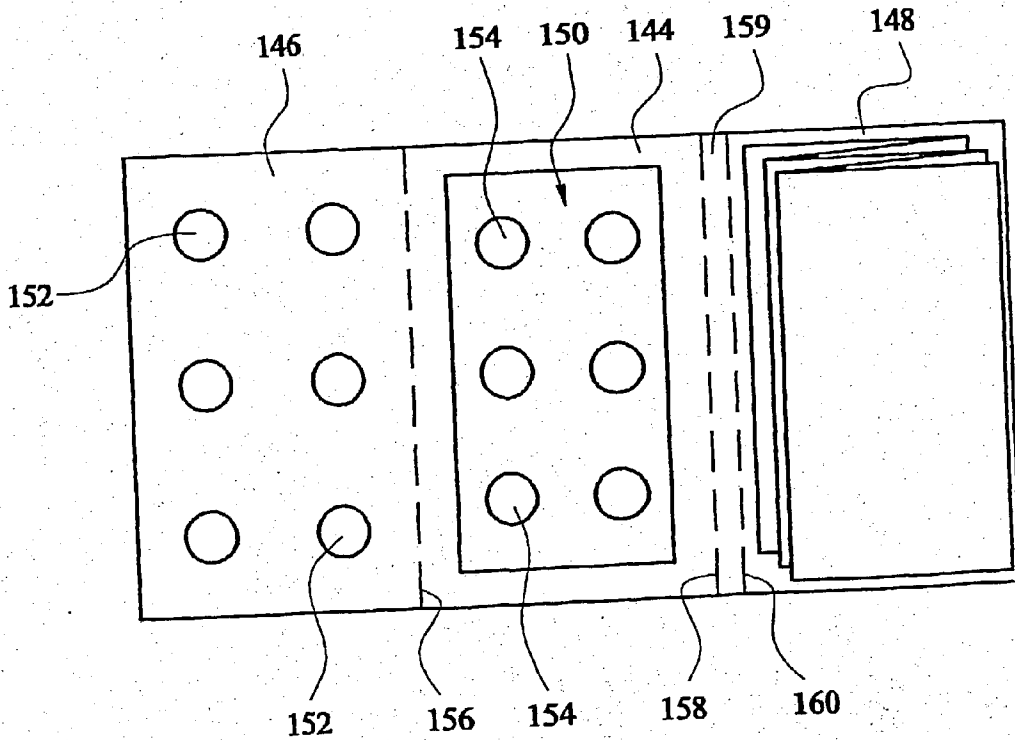

**FIG. 16**

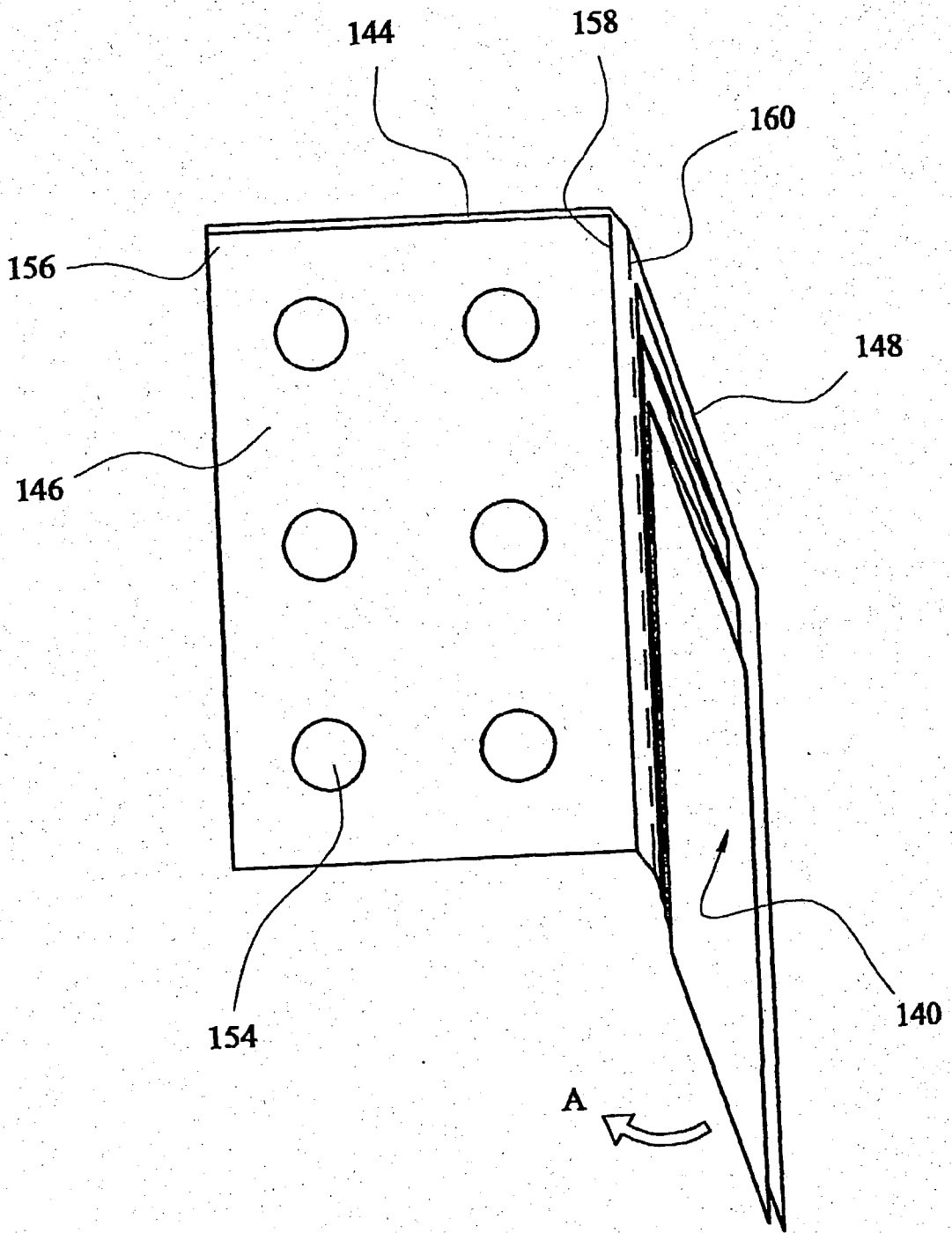

FIG. 17

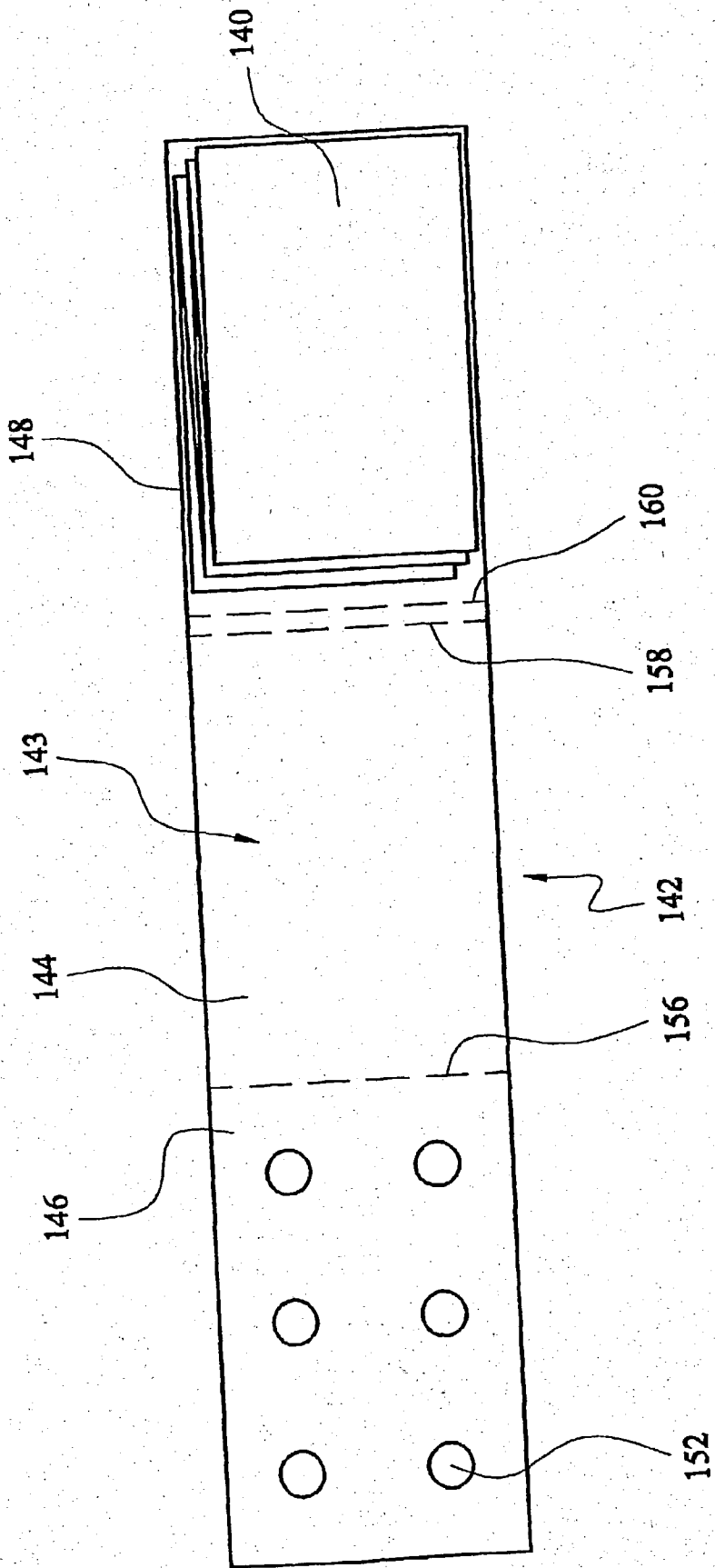

FIG. 18

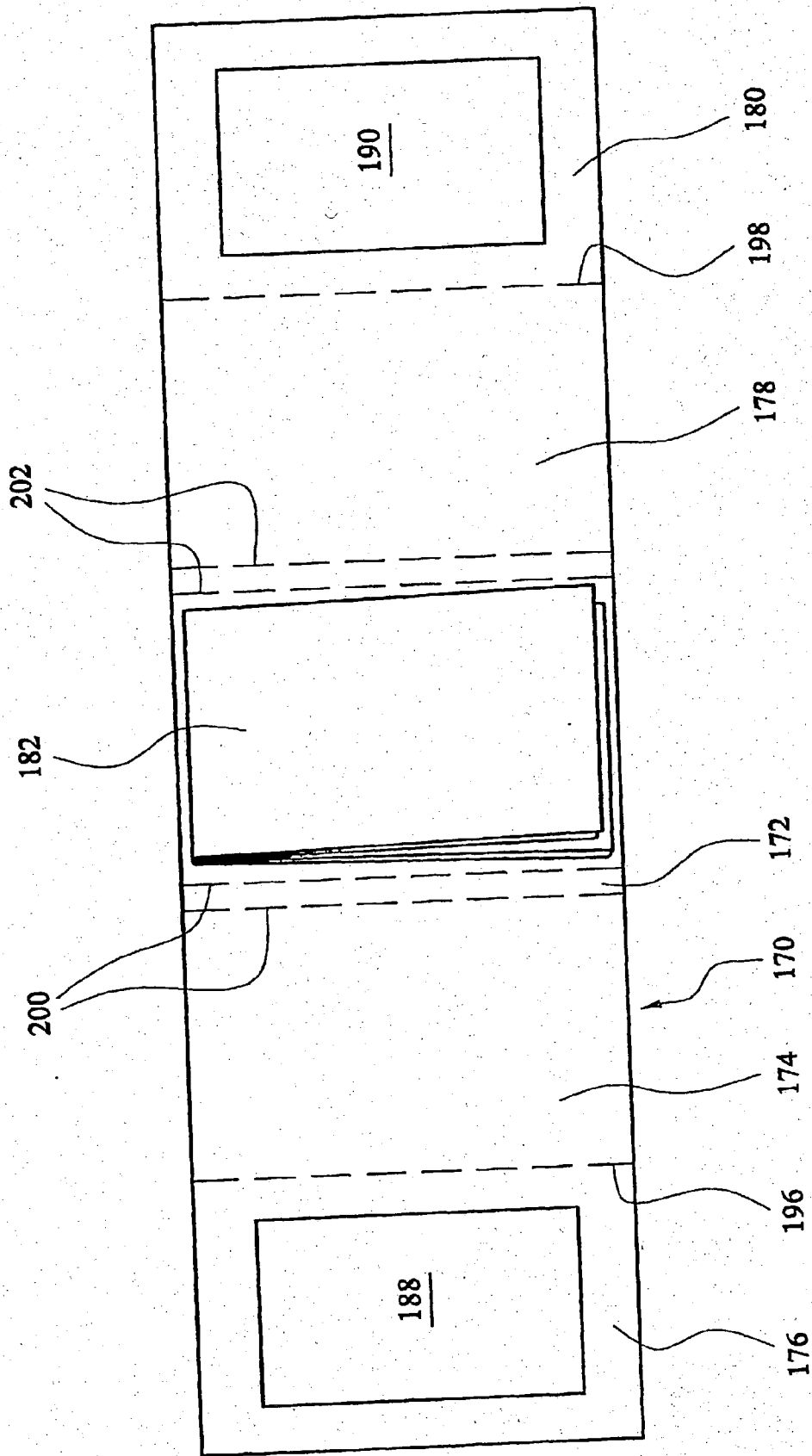

FIG. 19

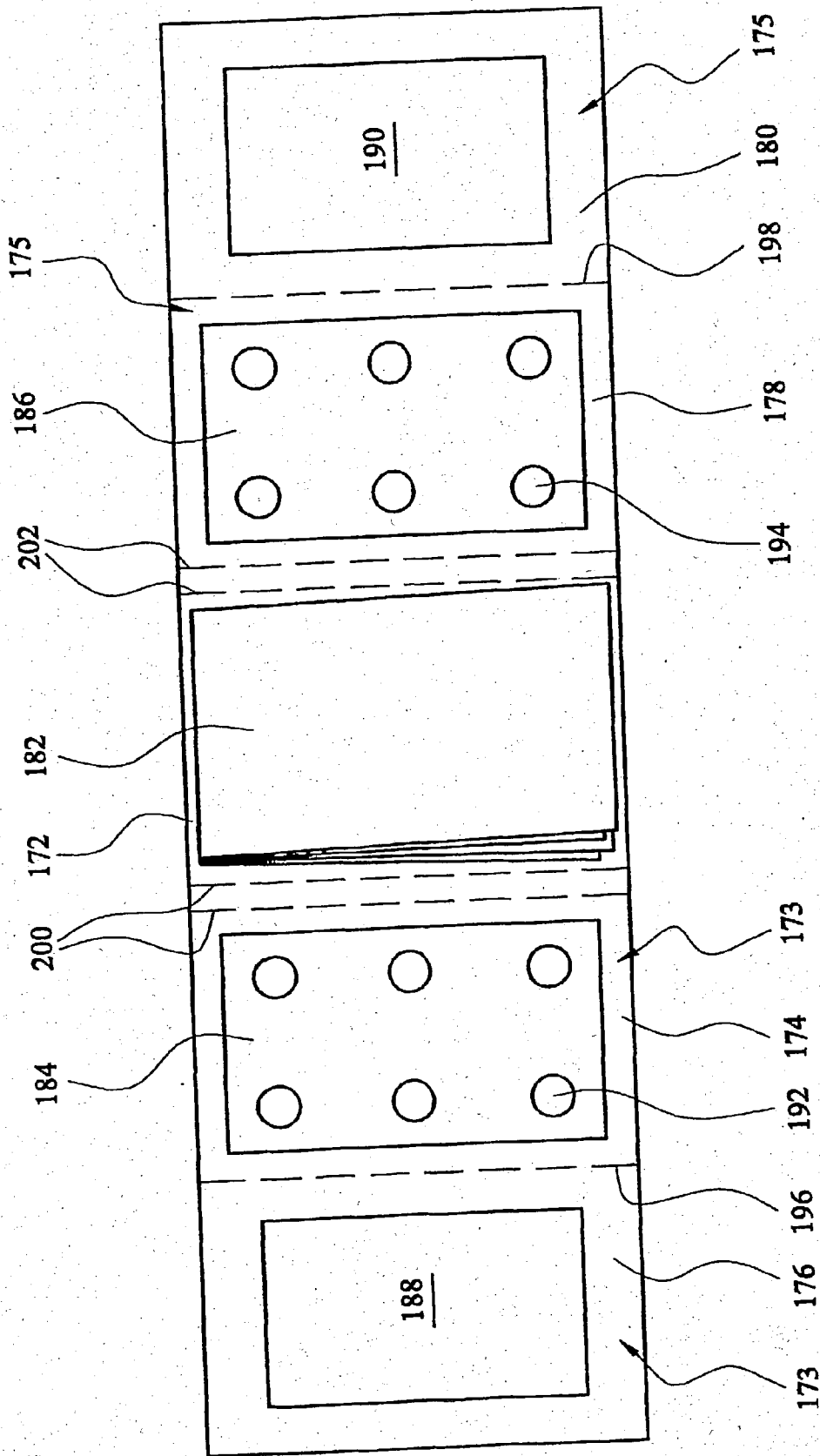

FIG. 20

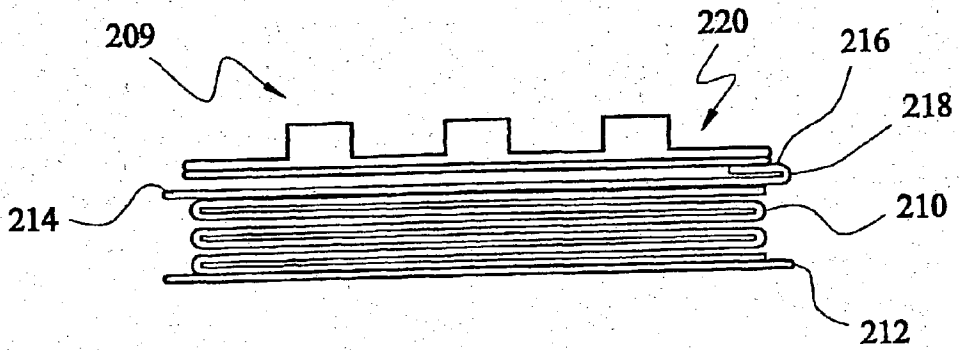

FIG. 21

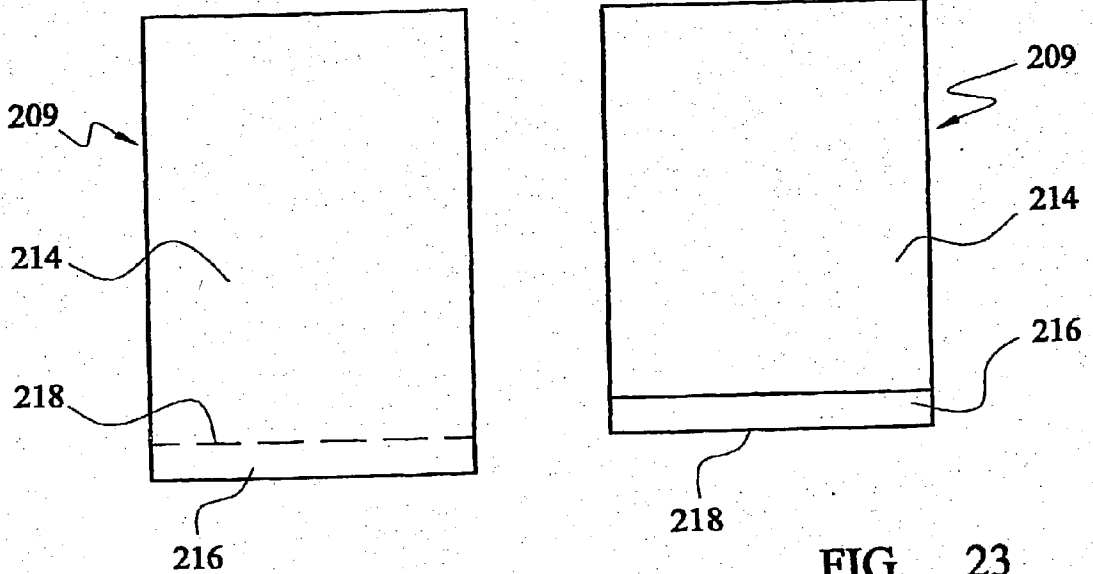

FIG. 22

FIG. 23

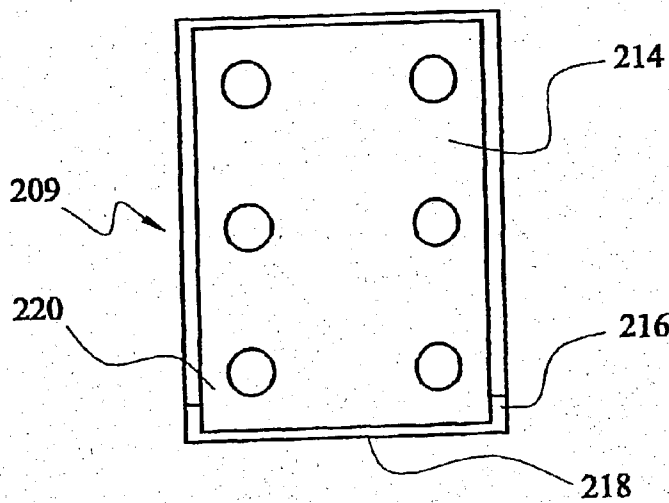

FIG. 24

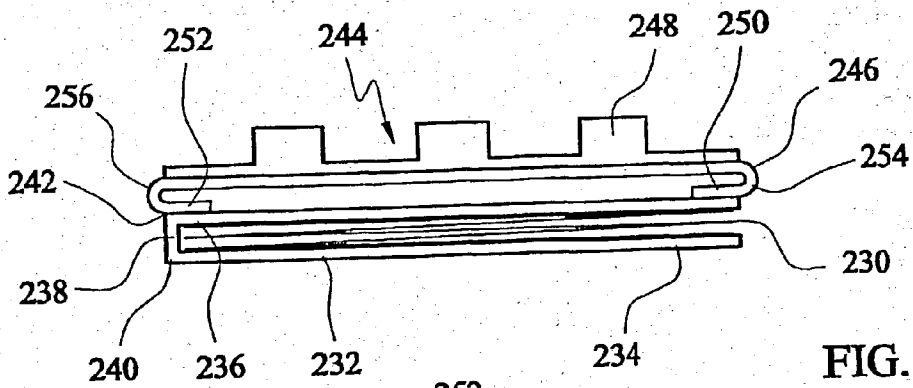

FIG. 25

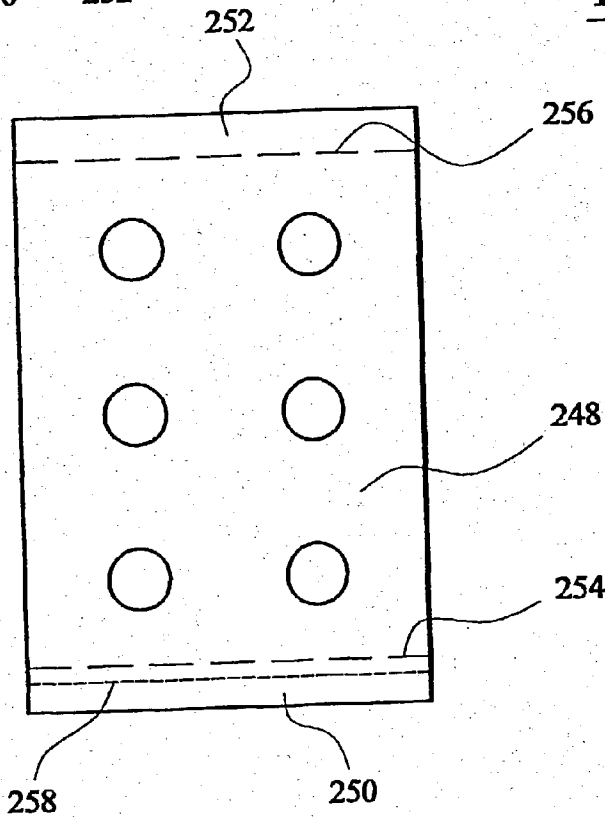

FIG. 26

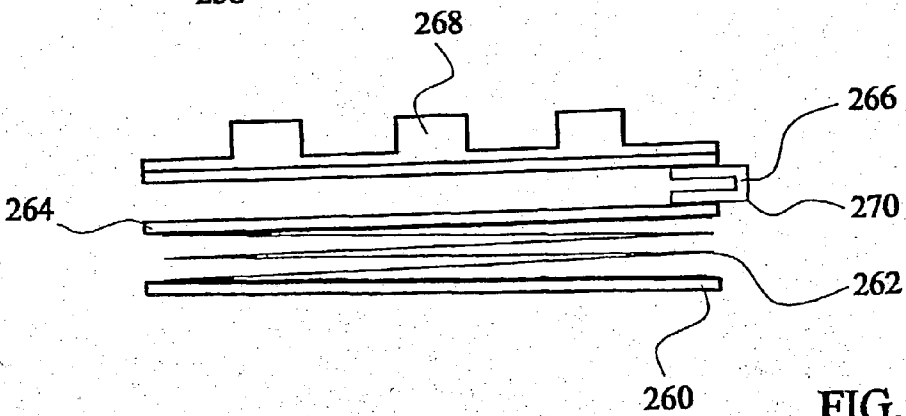

FIG. 27

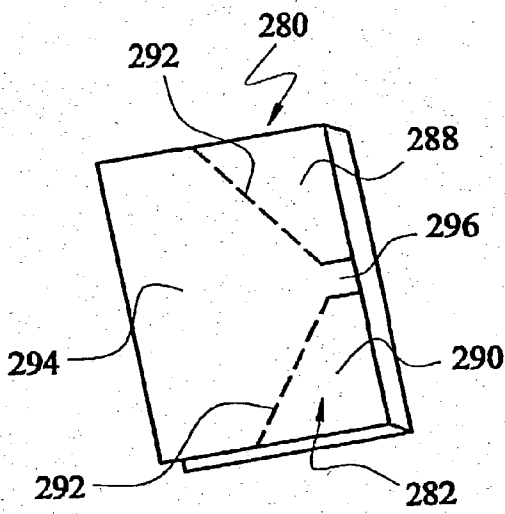

FIG. 28A

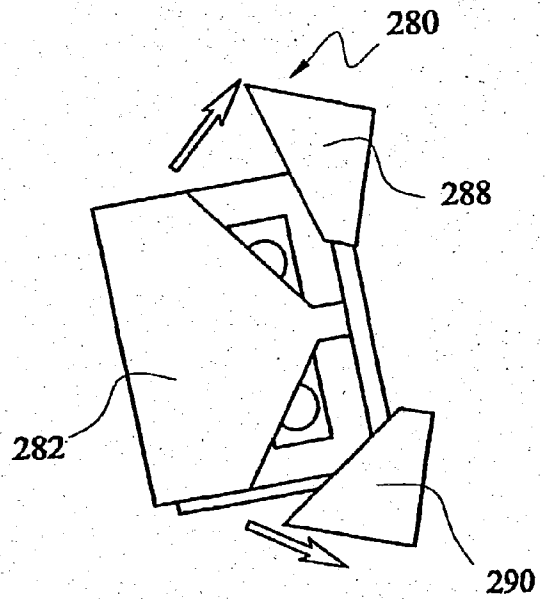

FIG. 28B

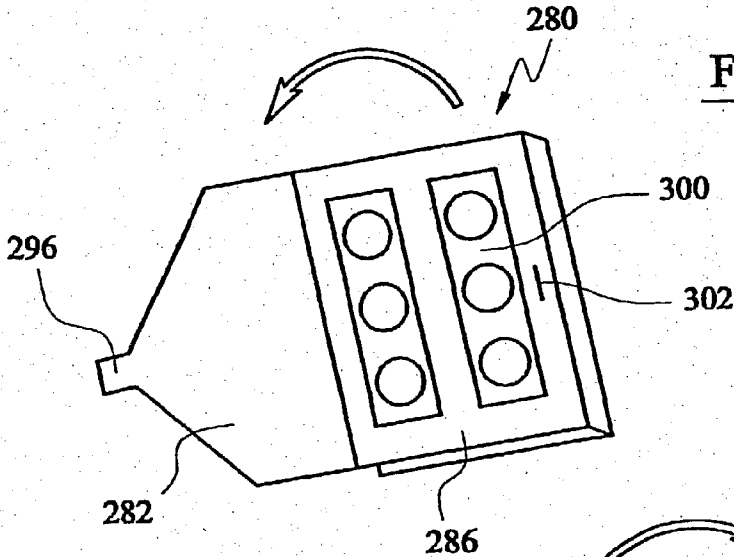

FIG. 28C

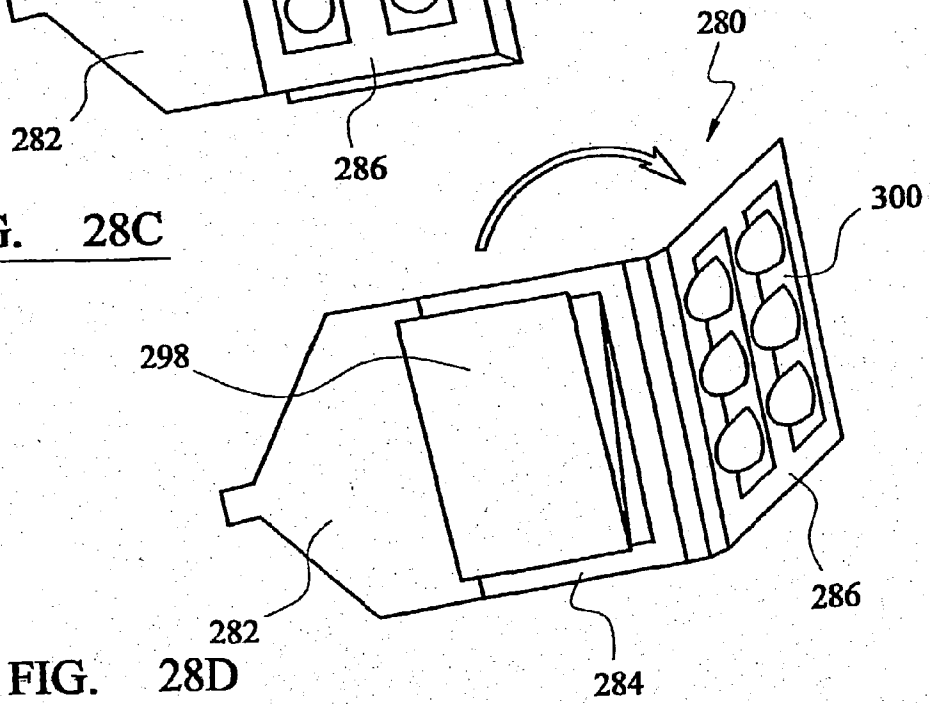

FIG. 28D

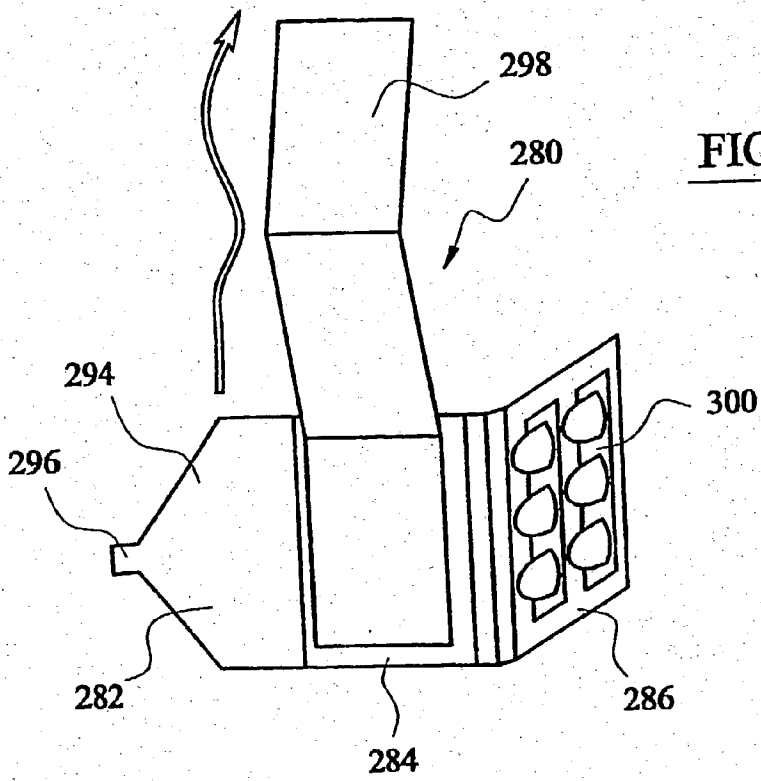

FIG. 28E

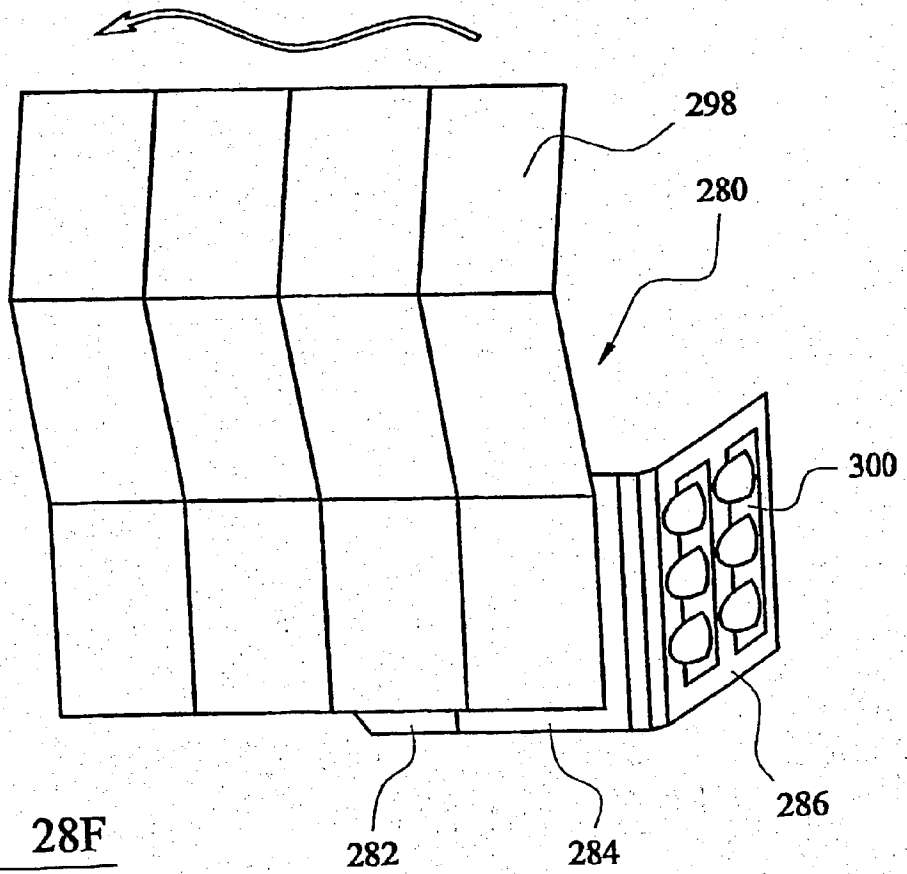

FIG. 28F

## FOLDED SHEET PRODUCT

### FIELD OF THE INVENTION

[0001] The present invention relates to folded sheet, products, whether in a folded or unfolded condition.

### BACKGROUND OF THE INVENTION

[0002] It is known from European Patent No. EP-A-288 472 to provide a folded sheet product comprising folded sheet with a first and second set of concertina folds, which sets of folds are transverse to one another. Provision of such folded sheets with stiff portions at segments of the sheet in the region of diagonally opposite corners of the sheet provides a means of easily unfolding and refolding the sheet material.

[0003] Manufacturers of pharmaceuticals must supply product information with the products they sell, in particular with pre-packaged products that are sold without prescription. This product information is important so that the purchaser is aware of the manner in which the product should be used, the dosage, any possible side effects of taking the product and what to do in an emergency.

[0004] This type of product information is generally enclosed in the packaging of the product in the form of a leaflet. A problem associated with such products, is that consumers rarely read the product information set out on the leaflet. Also, the leaflet often remains wedged in the packaging and is disposed of with the packaging once the product has been removed therefrom. Furthermore, as a result of automated and high speed packaging processes the wrong leaflet can be supplied with a product.

[0005] Manufacturers of other products such as shampoos, moisture creams, cosmetics, instant coffee, artificial sweeteners, seeds for gardening etc, often use blister strips to distribute samples of their products for advertising purposes. A disadvantage of this arrangement is that only a limited amount of product information, if any at all, can be displayed on blister strips.

[0006] It is an aim of preferred embodiments of the present invention to overcome problems associated with the prior art, whether mentioned herein or otherwise.

### SUMMARY OF THE INVENTION

[0007] Generally, unless otherwise stated herein, the phrase "sheet" is hereby defined as a material that takes folds at which it can be unfolded without the folds disappearing and refolded. It may be paper, or a paper-like material such as plastics sheet on which books are commonly printed, or may be very thin card or any other suitable material. It is conceivable that the sheet material may be stiff card except at the folds, e.g. very thin stiff cards interconnected by paper or cloth, but this is deprecated as not allowing full realisation of the advantages of the invention.

[0008] The present invention provides a folded sheet product comprising a folded sheet having a first set of folds and a blister strip attached to a segment of said sheet.

[0009] Unless otherwise stated herein, the phrase "blister strip" means a packaging arrangement comprising a cover sheet and a substrate. The cover sheet comprises one or more indentations in which a product can be contained. The

substrate is attached to the cover sheet so as to cover the openings of the indentations \*and thereby seal the product therein. The substrate usually comprises a foil or film material that can be easily ruptured or pierced to release the product by pushing the exterior surface of the indentation inwards. However, the substrate may be such that it is less easily ruptured. In this case, the substrate and or the cover sheet must be cut or torn in the region of the indentation to release the product.

[0010] The blister strip may be attached directly or indirectly to the folded sheet.

[0011] Suitably, the blister strip is located at or near a corner segment of the sheet. If the sheet comprises a single row of segments, the blister strip is suitably located at an end segment of the row.

[0012] The blister strip may be attached to a segment of the sheet by any suitable means, for example, by an adhesive. Heat sealing techniques may be used to attach the blister strip to a segment of the sheet.

[0013] The substrate of the blister strip may be attached to the folded sheet. Alternatively, the substrate of the blister strip may be provided by a segment of the sheet.

[0014] Suitably, the segment of the sheet to which the blister strip is attached comprises perforations. The perforations are arranged to facilitate removal of the product from the blister strip. Suitably, the perforations correspond in location with the opening(s) of the indentation(s) of the cover sheet of the blister strip. The perforations may be substantially X shaped.

[0015] Alternatively, or in addition, the segment of the sheet to which the blister strip is attached may comprise one or more cut out sections, which one or more cut out sections suitably correspond in location with the opening(s) of the indentation(s) of the cover sheet of the blister strip.

[0016] The one or more perforations and/or cut out sections may define an opening in the sheet having any suitable shape for example, circular or rectangular. Suitably, the one or more openings defined by the one or more perforations and/or cut out sections has or have dimensions which correspond substantially with the dimensions of the one or more openings of the indentations of the blister strip. A single cut out section and/or perforated region may be provided for each indentation of the blister strip. Alternatively, a single cut out section and/or perforated region may be provided for a plurality of indentations of the blister strip.

[0017] Suitably, a folded sheet product in accordance with the present invention further comprises a stiff portion. Suitably, the stiff portion is attached to a segment of the folded sheet. The stiff portion may be provided by the blister strip.

[0018] Alternatively, the stiff portion may be separate from the blister strip. If the stiff portion is separate from the blister strip, the stiff portion may be attached to the blister strip or the stiff portion may be at a separate segment of the sheet.

[0019] The substrate of the blister strip may be attached to the stiff portion. Alternatively, an edge of the stiff portion may be attached to an edge of the blister strip.

[0020] Suitably, the stiff portion is substantially the same size and/or shape as the blister-strip.

[0021] An edge of the stiff portion may be attached to an edge of the blister strip by any suitable means. For example, the stiff portion and/or the blister strip may have a marginal flange extending along a portion of the edge for attachment therebetween. The marginal flange may extend along a major portion or substantially the full length of the edge.

[0022] If the marginal flange extends from the stiff portion it may be attached directly to the blister strip. Alternatively, the marginal flange of the stiff portion may be attached indirectly to the blister strip. The blister strip may also comprise a marginal flange, to which the marginal flange of the stiff portion is either directly or indirectly attached.

[0023] If the marginal flange extends from the blister strip it may be attached directly to the stiff portion. Alternatively, the marginal flange of the blister strip may be attached indirectly to the stiff portion.

[0024] The marginal flange may be attached to the stiff portion and/or the blister strip by any suitable means, for example, by means of an adhesive.

[0025] The marginal flange may comprise a line of weakness, e.g. a perforated tear line, extending along the length thereof to facilitate removal of the blister strip from the stiff portion.

[0026] Suitably, a fold line is provided between the marginal flange and the edge of the stiff portion and/or the edge of the blister strip from which it extends.

[0027] Suitably, the blister strip can be arranged to lie flat against the stiff portion.

[0028] The marginal flange may be an extension of the stiff portion and/or the blister strip, which may form another stiff portion. Alternatively, the marginal flange may be provided by a tab which is attached to the edge of the stiff portion and/or the blister strip.

[0029] Once an edge of the blister strip has been attached to an edge of the stiff portion, one or more of the free edges of the blister strip may be fastened to a corresponding edge of the stiff portion by fastening means in order to maintain the blister strip folded against the stiff portion. Suitably, the fastening means temporarily fasten the one or more free edges of the blister strip against the stiff portion. The fastening means may, be re-usable, so that the blister strip may be unfastened and then refastened in its folded condition against the stiff portion.

[0030] Suitable fastening means are disclosed in GB 2263885 as referred to below.

[0031] The blister strip may be attached to the stiff portion at a plurality of edges suitably, opposing edges of the blister strip are attached to corresponding opposing edges of the stiff portion. Suitably, one or both of the marginal flanges, comprises a line of weakness to facilitate separation of an edge of the blister strip from the corresponding edge of the stiff portion.

[0032] The blister strip may be arranged relative to the stiff portion such that the cover sheet is adjacent the stiff portion or such that the substrate is adjacent the stiff portion.

[0033] Suitably, the stiff portion is located at or near a corner segment of the sheet. If the sheet comprises a single row of segments, the stiff portion is suitably located at an end segment of the row.

[0034] Suitably, a stiff portion and a separate blister strip are located at substantially diagonally opposite corners of the sheet.

[0035] The stiff portion may comprise one or more folds dividing the stiff portion into separate stiff portion segments. Suitably, the one or more folds is or are parallel to an edge of the stiff portion. If the stiff portion comprises a plurality of folds, the plurality are suitably parallel to one another. Suitably the plurality of folds form a spine when folded.

[0036] A folded sheet in accordance with the present invention may comprise a second stiff portion. Suitably, the second stiff portion is located at or near a corner segment of the sheet. Preferably, the second stiff portion is located at a segment of the sheet, which is diagonally opposite the segment at which the first stiff portion is located.

[0037] The second stiff portion may be provided by a second blister strip.

[0038] A stiff portion may be provided by a segment of the sheet that has been treated to make it stiffer than the rest of the sheet. For example, a segment may be soaked in a UV curable resin and then cured to provide the stiff portion.

[0039] Suitably, the blister strip provides an outside cover of the sheet when the sheet is in a folded condition. If the folded sheet material comprises a stiff portion, the stiff portion suitably provides an outside, cover of the sheet when the sheet is in a folded condition.

[0040] If a folded sheet in accordance with the present invention comprises two stiff portions, both of the stiff portions suitably provide a cover of the sheet when the sheet is in a folded condition.

[0041] A stiff portion (like a book-cover) may comprise a fold such that a flap-over cover is provided for the folded sheet when in a folded condition. The fold may be, provided by two stiff portions connected together along corresponding edges to provide a flap-over cover. As a further alternative a flap-over cover may be provided by two connected blister strips or a blister strip and a stiff portion.

[0042] If a flap-over cover is provided, the cover suitably comprises closure means to maintain the sheet folded. Suitable closure means are disclosed in United Kingdom patent specification number 2 263 885, the disclosure of which is incorporated herein by reference.

[0043] Suitably, the first set of folds is a set of concertina folds.

[0044] The first set of, folds may form the folded sheet into a single row of segments.

[0045] The folded sheet material may further comprise a second set of folds, which-second set of folds are transverse to said first set of folds when said sheet is in a folded condition. Suitably, said second set of folds comprises a set of concertina folds.,

[0046] Suitably, the first set of folds comprises an odd number of folds. Suitably, the second set of folds comprises an even number of folds.

[0047] Although one or both sets of folds may be non-parallel, e.g. convergent, and/or one or both of the stiff portions may, when the sheet is folded, not be outer portions, in a preferred embodiment-the sheet is rectangular, the sets

of folds being mutually perpendicular and parallel to the respective edges of the sheet, and the stiff portions being such as to be at the outside of the sheet when it has been folded by the first and second set of folds and being at least as large as the respective corner segments of the sheet.

[0048] The indentations of the blister strip may be located on the inside or the outside of the sheet when the sheet is in a folded condition.

[0049] If the folded sheet comprises a row of segments the stiff portion is suitably located at an end segment of the folded sheet.

[0050] If the folded sheet comprises a first and second set of folds, the stiff portion is suitably located at a corner segment of the folded sheet.

[0051] Suitably, the stiff portion is located at the outside of the sheet when it has been folded.

[0052] Suitably, a stiff portion comprises a first section and a second section for at least partly sandwiching the blister strip between the first-section and the second section.

[0053] The folded sheet may be attached to the first and/or second section of the stiff portion. Alternatively, or as well, the folded sheet may be attached to a further section of the stiff portion.

[0054] Suitably, the sections of the stiff portion, are of substantially the same size. However, the sections of the stiff portions may be of different sizes.

[0055] Suitably, the first section of the stiff portion is at least as large as the segment of the sheet to which it is attached.

[0056] Suitably, the second section of the stiff portion attaches the blister strip to the first section of the stiff portion.

[0057] Although the first and second sections of the stiff portion may be provided by separate elements, the first and second sections are preferably provided by a single element and are separated from one another by means of a fold line.

[0058] The folded sheet may be attached to one surface of the stiff portion and the blister strip is connected to another surface of the stiff portion.

[0059] The stiff portion may comprise a second stiff portion to which the folded sheet is attached. Preferably, the third section is attached to the first section. Although, the third section may be attached to the second section. Suitably, the second stiff portion is separated from the first stiff portion by a further fold line.

[0060] Suitably, a cover portion is provided to cover the blister pack. Suitably, the cover portion comprises a further stiff portion.

[0061] Suitably, the folded sheet is provided at a first stiff portion, the blister pack is provided at a second stiff portion and the cover portion is a third stiff portion.

[0062] Suitably, the stiff portions are foldably connected. Suitably, the first stiff-portion is between the second and third stiff portions whereby the second stiff portion can fold over the folded sheet and the third stiff portion can cover at least partly, the second stiff portion.

[0063] Suitably, part of the third stiff portion is attached to the second portion. Suitably, the part of the third portion attached to the second portion is releasably connected to another part of the third portion, preferably by a perforation, whereby the blister pack can be accessed by separating the attached part of the third stiff portion from the rest of the third stiff portion.

[0064] A fastening means may be provided by a tongue and slot (which term includes a slit) arrangement of the second and third stiff portions. Suitably, the tongue is on the third stiff portion and the slot is on the second stiff portion. Suitably, the tongue is provided by removing the attached parts of third stiff portion from the rest.

[0065] Any of the sections of the stiff portion may be separated from one another by means of a plurality of fold lines. Suitably, the plurality of fold lines are substantially parallel to one another.

[0066] A plurality of fold lines may be used to provide a spine between one section of the stiff portion and another when the stiff portion is folded about the fold lines. The width of the spine may be used to take account of the thickness of the blister strip attached to the article. The width of the spine may be determined by the thickness of the blister strip. Suitably, the width of the spine between the outer most fold lines of the plurality of fold lines corresponds substantially with the thickness of the blister strip.

[0067] The second section of the stiff portion suitably comprises one or more openings therein. The opening in the second section of the stiff portion is suitably configured to receive indentations of a blister strip, when a blister strip is attached to the stiff portion.

[0068] The second section may comprise a plurality of openings each of a size suitable to receive one indentation of a blister strip.

[0069] The second section may comprise one or more openings of a size suitable to receive a plurality of indentations of a blister strip.

[0070] The openings in the second section of the stiff portion may have a shape that corresponds to the shape of the indentations of a blister strip. Alternatively, the openings of the second section of the stiff portion may have a novelty shape, for example, a star shape.

[0071] The second section may provide one or more separators between the indentations of a blister strip. The or each separator may be configured to separate rows and/or columns of indentations of the blister strip.

[0072] Suitably, a stiff portion comprises perforations. Suitably, the perforations correspond in location with the opening of the indentations of the cover sheet of the blister strip when attached thereto.

[0073] The first section may comprise one or more cut out sections, which sections correspond in location with the openings of the indentations of the cover sheet of the blister strip when attached thereto. The first section may provide one or more separators between openings of the indentations of the blister strip. The or each separator may separate rows and/or columns of openings of the indentations of the blister strip.

[0074] The perforations and/or cut out sections in the first stiff portion are arranged to facilitate removal of the product from the blister strip.

[0075] The perforations and/or cut out sections may define an opening in the stiff portion having any suitable shape, for example, circular or rectangular. The perforations may be substantially X-shapes. Suitably, the openings defined by the perforations and/or cut out sections have dimensions that correspond substantially with the dimensions of the openings of the indentations.

[0076] A single perforated region and/or cut out section may be provided for each indentation of the blister strip. Alternatively, a single cut out section and/or perforated region may be provided for a plurality of indentations of the blister strip.

[0077] As would be apparent to a person skilled in the art, the openings in second section and/or the cut out sections or perforated regions of the first section may have dimensions slightly greater than the indentations or openings of the indentations respectively to allow for, tolerances in locating the blister strip on the stiff portion.

[0078] Suitably, in use of a preferred embodiment of the present invention, a blister strip is located on a surface of the first section of a stiff portion. The second section is then folded over the first section, such that the protrusions of the blister strip are received in the one or more openings of the second section and the first and second sections are then attached to one another.

[0079] The first and second sections may be attached to one another by any suitable means, for example, by means of an adhesive. A tamper-proof adhesive may be used such as a glue that changes colour on exposure to air. The first and second sections may be attached to one another using a heat sealing technique.

[0080] If the folded sheet is located on a third section of the stiff portion, the third section is suitably folded over the first and second sections. In this case, the protrusions of the blister strip are suitably covered by the third section of the stiff portion. The third section would then provide a degree of protection for the blister strip. The folded sheet may be located either inside or outside of the article when the third section is folded over the first and second sections.

[0081] The stiff portion may be provided with closure means, arranged to fasten the second stiff portion in a position wherein it is folded over the first stiff portion. Any suitable closure means may be used, for example, as described in GB 2 263 885 as referred to above.

[0082] The stiff portion may be arranged to allow a plurality of blister strips to be attached thereto.

[0083] The stiff portion may comprise more than three sections.

[0084] Suitably, the plurality of sections of the stiff portion are arranged to longitudinally abut one another.

[0085] According to the present invention in a second aspect, there is provided a folded sheet product comprising a folded sheet having at least a first set of folds, and a stiff portion at a segment of said sheet, in which the stiff portion comprises a tongue portion formable by removing at least

one part of the stiff portion which part is separated from the tongue portion by a frangible region.

[0086] Suitably, the frangible region is formed by a weakening of the stiff portion, which weakening is preferably formed by perforations.

[0087] According to the present invention in a third aspect, there is provided a folded sheet product comprising a folded sheet having a first set of folds and a stiff portion forming a sealable cover about the folded sheet, which product further comprises a tamper evident feature.

[0088] Suitably, the tamper evident feature comprises the cover being sealable whereby breaking the seal is visible.

[0089] Suitably, part of the cover is separable from another part of the cover to open the product.

[0090] Suitably, a cover portion is provided to cover the blister pack. Suitably, the cover portion comprises a further stiff portion.

[0091] Suitably, the folded sheet is provided at a first stiff portion, the blister pack is provided at a second stiff portion and the cover portion is a third stiff portion. Suitably, the stiff portions are foldably connected. Suitably, the first stiff portion is between the second and third stiff portions whereby the second stiff portion can fold over the folded sheet and the third stiff portion can cover at least partly, the second stiff portion.

[0092] Suitably, part of the third portion is attached to the second portion. Suitably, the part of the third portion attached to the second portion is releasably connected to another part of the third portion, preferably by a perforation, whereby the blister pack can be accessed by separating the attached part of the third stiff portion from the rest of the third stiff portion.

[0093] A fastening means may be a tongue and groove arrangement of the second and third stiff portions. Suitably, the tongue is on the third stiff portion and the groove is on the second stiff portion. Suitably, the tongue is provided by removing the attached parts of third stiff portion from the rest.

[0094] The present invention finds particular advantage in respect of medical products in tablet form. However, the present invention does not find its only application in medical products and can be used in respect of, any goods that can suitably be stored in and dispensed from blister strips, for example, product samples for advertising purposes.

[0095] In order to, ensure that the information leaflet corresponds to the product in the blister strip, a corresponding barcode may be applied to the sheet and the blister strip. During assembly of the product a barcode reader would then be used to check that the codes correspond and only allow assembly of the product when this is the case.

[0096] Another advantage of the present invention resides in the fact that the information leaflet is part of or attached to the blister strip and in some cases no additional packaging is required. This means products or samples are easier to manufacture and cheaper to manufacture.

[0097] However, once assembled the finished product may be subjected to further packaging such as shrink wrapping or packaging in a box.

## BRIEF DESCRIPTION OF THE DRAWINGS

[0098] The present invention will now be described, by way of example only, with reference to the following drawings, in which:

[0099] FIG. 1 shows a plan view of a first embodiment of a folded sheet material in accordance with the present invention in a folded condition.

[0100] FIG. 2 shows a plan view of the sheet of FIG. 1 in a partially unfolded condition.

[0101] FIG. 3 shows the sheet of FIGS. 1 and 2 in an unfolded condition.

[0102] FIG. 4 shows a side view of the sheet of FIGS. 1, 2 and 3 in a folded condition.

[0103] FIG. 5 shows a front plan view of a second embodiment of a folded sheet material in accordance with the present invention in a substantially unfolded condition.

[0104] FIG. 6 shows a rear plan view of the sheet of FIG. 5.

[0105] FIG. 7 shows a side view of a third embodiment of a folded sheet material in accordance with the present invention, in a folded condition.

[0106] FIG. 8 shows a side view of a fourth embodiment of the present invention.

[0107] FIG. 9 shows a perspective view of a fifth-embodiment of a sheet in accordance with the present invention in a partially unfolded condition.

[0108] FIG. 10 illustrates an alternative embodiment of the folded sheet material of FIG. 9.

[0109] FIG. 11 illustrates an alternative embodiment of the folded sheet material of FIG. 10.

[0110] FIG. 12 illustrates a variation of the embodiment of the folded sheet of FIGS. 5 and 6.

[0111] FIG. 13 illustrates a perspective view of a sixth embodiment of a folded sheet material in accordance with the present invention, in a partially unfolded condition.

[0112] FIG. 14 illustrates a seventh embodiment of a folded sheet material in accordance with the present invention, in a folded condition.

[0113] FIG. 15 illustrates an eighth embodiment of a folded sheet in accordance with the present invention.

[0114] FIG. 16 shows the embodiment of FIG. 15 with a blister strip located thereon.

[0115] FIG. 17 shows the embodiment of FIG. 16 is a partially folded condition.

[0116] FIG. 18 shows an alternative arrangement of the embodiment of FIG. 15.

[0117] FIG. 19 shows a ninth embodiment of the present invention.

[0118] FIG. 20 shows the embodiment of FIG. 19 with a plurality of blister strips located thereon.

[0119] FIG. 21 shows a side view of tenth embodiment of the present invention.

[0120] FIG. 22 shows a plan view of part of the embodiment of FIG. 21 in an unfolded condition.

[0121] FIG. 23 shows a plan view of FIG. 22 in a folded condition.

[0122] FIG. 24 shows a plan view of the article of FIG. 21.

[0123] FIG. 25 shows a side view of an eleventh embodiment of the present invention.

[0124] FIG. 26 is a plan view of part of FIG. 25 in an unfolded condition.

[0125] FIG. 27 is a side view of a twelfth embodiment of the present invention.

[0126] FIGS. 28A-28F are perspective views of a thirteenth embodiment of the present invention.

## DETAILED DESCRIPTION OF PREFERRED EMBODIMENTS

[0127] FIGS. 1, 2, 3 and 4 show a first embodiment of a folded sheet product 2: in accordance with the present invention.

[0128] The folded sheet product 2 of FIGS. 1, 2, 3 and 4 comprises a folded sheet 3 blister strip 4, providing a first stiff portion, a second stiff portion 6, a first set of folds 10 (represented by broken lines in FIG. 3) and a second set of folds 12 (represented by dotted lines in FIG. 3).

[0129] The stiff portion is relatively stiffer than the material at the folded sheet 3.

[0130] Both the first set of folds 10 and the second set-of folds 12 comprises a set of concertina folds.

[0131] The sheet 3 is a paper material.

[0132] The blister strip 4 is located at a corner segment 14 of the sheet 3. The second stiff portion is located at a corner segment 16 of the sheet 3. The corner segments 14 and 16 are at diagonally opposite corner segments of the sheet 3.

[0133] As can be more clearly seen from FIG. 4, the blister strip 4 comprises a cover sheet 18 comprising a plurality of indentations 20. The substrate of the blister strip 4, which covers the openings in the indentations, is provided by the segment 4 of the sheet 3 at which the blister strip 4 is located. The dashed markings on FIG. 3 indicate the locations of the indentations 20. In this case, the folded sheet material 3 should be such that it is easily ruptured by pushing the indentations 20 inwards to release the product (not shown) contained within the indentations 20.

[0134] FIGS. 5 and 6 illustrate a second embodiment of the invention.

[0135] The folded sheet product 30 illustrated in FIGS. 5 and 6 comprises a folded sheet 31, a blister strip 32, providing a stiff portion and a first set of folds 33 (represented by broken lines).

[0136] The blister strip 32 comprises a cover sheet 34 comprising a plurality of indentations 36, the substrate of the blister strip 32 is again provided by the segment of the sheet 38 at which the blister strip 32 is provided.

[0137] In this case, the sheet comprises perforations 40 (represented by broken lines), which perforations corre-

spond with the location of the openings in the indentations **36** (indicated in **FIG. 6** by dotted lines). Therefore, when an indentation **36** is pushed inwards to release the product contained therein (not shown), the corresponding perforations **40** tear to release the product.

[0138] **FIG. 7** illustrates a third embodiment of a folded sheet product **50** in accordance with the present invention.

[0139] The folded sheet product **50** of **FIG. 7** comprises a folded sheet **51**, a first stiff portion **52**, a second stiff portion **54** and a blister strip **56**. The folded sheet **51** comprises at least a first set of folds **58** and may comprise a second set of folds (not shown).

[0140] The blister strip **56** comprises a cover sheet **60** comprising a plurality of indentations **62** in which a product (not shown) can be located. The blister strip **56** further comprises a substrate **64** which is easily pierced or ruptured by pushing an indentation **62** inwards to release the product contained therein.

[0141] In this case, the first stiff portion **52** comprises a material that is also easily pierced or ruptured when an indentation **62** is pushed inwards to release the product contained therein. Alternatively, the stiff portion comprises perforations that correspond to the openings in the indentations **62**, as discussed in relation to the embodiment shown in **FIG. 6**.

[0142] **FIG. 8** illustrates a folded sheet product **70** in accordance with the present invention, comprising a folded sheet **72**, a blister strip **74** and a stiff portion **76**.

[0143] When in a folded condition the blister strip **74** of the folded sheet product **70** is located on the inside of the sheet. The stiff portion **76** is located on the outside of the folded sheet **72** and thereby provides a cover for said sheet **72**.

[0144] A folded sheet product **70** as illustrated in **FIG. 8** may further comprise a second stiff portion **78** as, denoted by dashed lines in **FIG. 8**. The second stiff portion is located on the outside of the sheet **72** when the folded sheet product **70** is in a folded condition. The second stiff portion **78** also provides a cover for the sheet **72** when the folded sheet product **70** is in a folded condition.

[0145] **FIG. 9** illustrates a folded sheet product **90** in accordance with fifth embodiment of the present invention.

[0146] The folded sheet product **90** comprises a folded sheet **92**, comprising a first set of concertina folds, a first stiff portion **94**, a second stiff portion **95** and a blister strip **96**.

[0147] The first stiff portion **94** is separated from second stiff portion **95** by a fold **98**. The blister strip comprises indentations **100**.

[0148] In a folded condition, the stiff portions **94**, **95** (forming stiff portion segments) fold about fold line **98** to provide a cover for the folded sheet **92**. In this embodiment the blister strip **96** is located on the inside surface of the second stiff portion **95**.

[0149] In an alternative embodiment (not shown), blister strip **96** is located on the outside surface of the stiff portion **95**.

[0150] **FIG. 10** illustrates an alternative embodiment of the folded sheet product **90** of **FIG. 9**. In this embodiment

the, blister strip **96** is located on the outside surface of the end segment **102** of the folded sheet **92**. In an alternative embodiment (not shown) the blister strip **96** may be located on the inside surface of the end segment **102** of the folded sheet **92**.

[0151] Furthermore, the stiff portion **94** comprises two fold lines **98a** and **98b** defining a spine **99**. The stiff portions **94**, **95** provide a cover which folds about fold lines **98a** and **98b** to enclose the folded sheet **92** and the blister strip **96**.

[0152] **FIG. 11** shows an alternative arrangement of the embodiment of **FIG. 10**, wherein like numerals refer to like features. The embodiment of **FIG. 11** comprises stiff portion **94**, **95** which comprise fold lines **98a** and **98b** parallel to the narrow edge of the folded sheet **92** and the stiff portions **94**, **95**. The stiff portions **94**, **95** again providing a flap-over cover by means of folds **98a** and **98b**.

[0153] **FIG. 12** shows a variation of the embodiments shown in **FIGS. 5 and 6**, wherein like features are represented by like reference numerals.

[0154] Like the embodiment shown in **FIGS. 5 and 6**, the folded sheet product **30** illustrated in **FIG. 12** comprises a folded sheet **31**, a blister strip **32**, providing a stiff portion and a first set of folds **33**. (represented by dashed lines).

[0155] The blister strip **32** comprises a cover sheet **34** comprising a plurality of indentations **36** (represented by dotted lines). The substrate of the blister strip is provided by a foil sheet **37**.

[0156] In place of perforations **40** of **FIG. 6**, the sheet product **30** of **FIG. 12** comprises cut out sections **39**, which correspond with the location of the openings of the indentations **36**. The columns of indentations **36** are separated by a separator **41**. As the indentation **36** it pushed inwards, the foil tears and the product passes out of the opening, through the broken foil substrate **37** and through the cut of section **39** of the sheet.

[0157] **FIG. 13**, shows a sixth embodiment of a folded sheet product **100** in accordance with the present invention.

[0158] The folded sheet product **100** comprises a folded sheet **101** within first set of concertina folds **102** and a second fold **104**. The folded sheet product **100** further comprises a first stiff portion **106** and a second stiff portion **107** foldably connected thereto by a fold line **108**, which fold line is around the centre of the stiff portions **106**, **107** and is substantially parallel with the short edge of the stiff portion **106** as illustrated in **FIG. 13**. The folded sheet product **100** further comprises a blister strip **110** attached to the outer surface of a segment **112** of the stiff portion **107**.

[0159] In a folded condition, the sheet **101** of the folded sheet product **100** is folded by means of concertina folds **102** and then folded in half along fold line **104**. The adjacent end segments of each row of the folded sheet **101** are attached to each segment of the respective stiff portions **106**, **107**. Therefore, when the sheet **101** is folded in half along fold line **104**, the stiff portion is folded in half along fold line **108**.

[0160] When in a folded condition, the stiff portions **106**, **107** provide a cover for the folded sheet **101**. The folded sheet product **100**, may be provided with suitable closure means to maintain the article in a folded condition.

[0161] In this embodiment, the blister strip 110 is located with the indentations (not shown) on the external surface of the second stiff portion 107. However, the blister strip 110 may be located in any other suitable location of the folded sheet material 100.

[0162] To open the folded sheet, the stiff portions 106, 107 are unfolded about fold line 108 which in turn causes sheet 101 to be unfolded about fold line 104. The sheet can then be unfolded about concertina folds 102 by pulling the free edge 116 of the sheet 101 in the direction illustrated by arrow A.

[0163] FIG. 14 shows a folded sheet product 120, which comprises a first stiff portion 122, a second stiff portion 124, a folded sheet 126, a blister strip 128 and a pocket 130.

[0164] The pocket 130 comprises a cover portion 132, which cover portion 132 has a cut-out section 134. The pocket 130 may also comprise a base portion (not shown), which base portion would require a cut out section (not shown) corresponding with cut out section 134.

[0165] The blister strip 128 comprises indentations 136, which indentations 136 protrude through the cut out section 134 when the blister strip 128 is inserted in the pocket 130, as illustrated.

[0166] In order to allow for removal of the product contained in the indentations 136 whilst the blister strip 128 remains in the pocket 130, a cut out section (not shown) corresponding to cut out section 134 could be provided in the second stiff portion 124. If the second stiff portion 124 is attached to a segment of the sheet 126 a corresponding cut out section would need to be provided in the sheet. Alternatively, the second stiff portion 124w and/or the sheet 126 may comprise perforated sections (not shown) which correspond with the openings (not shown) of the indentations 136.

[0167] The blister strip 128 is inserted into the pocket 130 through opening 138. Once all the product has been removed from the indentations 136 of the blister strip 128, the blister strip 128 may be removed from the pocket 130 via opening 138 and a replacement strip 128 may be inserted into the pocket 130.

[0168] The second stiff portion 124 may be omitted from the folded sheet material 120. In which case, the pocket 130 or the folded sheet 126, or the blister strip 128 may serve as a replacement therefor.

[0169] The cover portion 132, at least, of the pocket 130 comprises material which is sufficiently deformable to allow for insertion and removal of the blister strip 128 whilst maintaining a grip on the blister strip 128 to maintain it inside the pocket 130 during use.

[0170] The opening 138 of the pocket 130 may comprise closure means (not shown) to prevent accidental removal of the blister strip 128 from the pocket 130.

[0171] FIG. 15 shows a folded sheet product 142 comprising a folded sheet 140 attached to a first stiff portion 148, which first stiff portion 148 is foldably connected to a second stiff portion 143 made up of a first section 144 and a second section 146.

[0172] The second section 144 is suitable for receiving a blister strip 150, as shown in FIG. 16.

[0173] The second section 146 comprises a plurality of openings 152 suitable for receiving the indentations 154 of the blister strip 150.

[0174] The first section 144 of the second stiff portion 143 is separated from the second section 146 by means of a fold line 156 (indicated by broken line). The first section 144 of the second stiff portion 143 is separated from the first stiff portion 148 by two parallel fold lines 158 and 160 (also indicated by broken lines).

[0175] In use of the article of FIGS. 15, 16 and 17, a blister strip 154 is located on the first section 144 of the second stiff portion 143. The second stiff portion 143 is then assembled by being folded along fold line 156, so that the second section 146 is superimposed over the first section 144. The openings 152 of the second section 146 are arranged to receive the indentations 154 of the blister strip when the second section 146 is superimposed on the first section 144. The first section is adhered to the second section by heat-sealing techniques, thus attaching the blister strip 150 on the second stiff portion 143 and indirectly to the folded sheet 140.

[0176] The first stiff portion 148 is then folded over the first and second sections 144, 146, now together second stiff portion 143 as illustrated by arrow A in figure 17. The pair of fold lines 158, 160 provide a degree of spacing between the third section 148 and the first and second sections 144, 146 to form a spine 159, so that the third section 148 lies flat over the indentations 154 when folded. The spacing of the fold lines 158, 160 corresponds to the depth of the indentations 154 and allows for the thickness of the folded sheet.

[0177] FIG. 18 shows the article of FIGS. 15-17, but the stiff portion 148 and sections 144, 146 and 148 of the stiff portion 142 are arranged differently relative to one another. An article as shown in FIG. 18 can have manufacturing advantages over the article of FIGS. 15-17, in that a narrower manufacturing conveyor can be used.

[0178] FIGS. 19 and 20 show an alternative embodiment of the invention, wherein the cover 170 comprises first, second and third foldably connected stiff portions 172, 173 and 175 respectively. Second stiff portion 173 is made up from first and second sections 174, 176. Third stiff portion 175 is made up from third and fourth sections 178, 180.

[0179] A folded sheet 182 is attached to the first stiff portion 172. The first 174 and third 178 sections are each suitable for receiving a respective blister strip 184 and 186 as shown in FIG. 20.

[0180] The second 176 and fourth 180 sections each comprise an opening 188 and 190 respectively for receiving the indentations 192 and 194 of the blister strips 174 and 178 respectively.

[0181] In use, the blister strips 184 and 186 are located on the first 174 and third 178 sections of the stiff portions 173, 175 respectively.

[0182] The stiff portion 170 is then folded about fold line 196 (indicated by broken line) to superimpose the second portion 176 onto the first portion 174. The first 176 and third 174 sections are then adhered to one another in order to attach the blister strip 184 to the stiff portion 173.

[0183] The fourth section 180 is attached to the third section 178 in the same manner, by folding about fold line 198.

[0184] The first/second sections and the third/fourth sections may then be folded over the first stiff portion 172, by folding about parallel pairs of fold lines 200 and 202 respectively.

[0185] Although, FIGS. 19 and 20 illustrate an article wherein the blister strips 184, 186 are located on the same side of the respective stiff portions 173, 175, the blister strips 184, 186 may be located on opposing surfaces of the stiff portions 173, 175. The first/second sections 174, 176 and the third/fourth sections 178, 180 may also be folded over opposing surfaces of the first stiff portion 172.

[0186] FIGS. 21 to 24 show a folded sheet product 209 comprising a folded sheet 210 having a first stiff portion 212 attached to a segment thereof and a second stiff portion 214 attached to another segment thereof.

[0187] The second stiff portion 214 comprises a marginal flange 216 extending therefrom and separated therefrom by fold line 218. An edge of a blister strip 220 is attached to an edge of the second stiff portion 214 by means of the marginal flange 216.

[0188] FIGS. 22 and 23 show a plan view of the article of FIG. 21 without the blister strip 220 attached thereto. The fold line 218 is designated by the broken line in FIG. 22.

[0189] FIG. 25 shows an article having a folded sheet 230 with a first stiff portion, 232 attached to a segment thereof. First stiff portion 232 is foldably connected to second stiff portion 236 separated from each other by a spine 238 formed by two folds 240, 242.

[0190] Opposing edges of a blister strip 244 comprising a substrate 246 and a cover 248 are attached to corresponding edges of the second stiff portion 236 by means of marginal flanges 250, 252. The marginal flanges 250, 252 are extensions of the substrate 246 of the blister strip 248 and are separated from the blister strip by fold lines 254, 256.

[0191] FIG. 26 shows a plan view of the blister strip 244 of FIG. 26 in an unfolded condition. Flange 250 comprises a tear line 258 illustrated by a dashed line, to provide a means of releasing one end of the blister strip 244 from the stiff portion 232, 236.

[0192] FIG. 27 shows an article comprising a first stiff portion 260 attached to a segment of a folded sheet 262, a second stiff portion 264 attached to another segment of the folded sheet 262, a tab 266 and a blister strip 268.

[0193] The tab 266 is folded along fold line 270. A first section is attached to the second stiff portion 264 and a second section is attached to the blister strip 268.

[0194] FIGS. 28A-28F show a folded sheet product 280 according to a further embodiment of the present invention. The product 280 comprises a first stiff portion 282 foldably connected to a second stiff portion 284, foldably connected to a third stiff portion 286. Fold lines separate the respective stiff portions, with spacing spines to provide for blister pack and folded sheet thickness.

[0195] First stiff portion 282 comprises a first tear off part 288 and a second tear off part 290 forming part of first stiff portion 282, but frangibly connected by perforations 292 to leave a tongue part 294 of first stiff portion, having a tongue 296.

[0196] A double-concertina folded sheet 298 is attached to second stiff portion 284.

[0197] A blister pack 300 is attached to third stiff portion 286, which is made up from two foldably connected sections as described with reference to FIGS. 15-18 above. Third stiff portion 286 also includes a slot or slit 302 for receiving tongue 296.

[0198] In use, the perforated parts 288, 290 can be torn off to reveal a tongue 296 that can be used to re-seal the package in slot 302. The product can then be opened as shown.

[0199] Alternatively, perforated parts 288, 290 can be affixed (eg adhered) to third stiff portion 286 so that tongue part 294 must be separated therefrom to open the product and access the blister pack 300. This had the additional advantages of providing a tamper evident seal over the blister pack 300 and also protecting it from premature rupture.

[0200] The reader's attention is directed to all papers and documents which are filed concurrently with or previous to this specification in connection with this application and which are open to public inspection with this specification, and the contents of all such papers and documents are incorporated herein by reference.

[0201] All of the features disclosed in this specification (including any accompanying claims, abstract and drawings), and/or all of the steps of any method or process so disclosed, may be combined in any combination, except combinations where at least some of such features and/or steps are mutually exclusive.

[0202] Each feature disclosed in this specification (including any accompanying claims, abstract and drawings), may be replaced by alternative features serving the same, equivalent or similar purpose, unless expressly stated otherwise. Thus, unless expressly stated otherwise, each feature disclosed is one example only of a generic series of equivalent or similar features.

[0203] The invention is not restricted to the details of the foregoing embodiment(s). The invention extend to any novel one, or any novel combination, of the features disclosed in this specification (including any accompanying claims, abstract and drawings), or to any novel one, or any novel combination, of the steps of any method or process so disclosed.

1. A folded sheet product comprising a folded sheet having a first set, of folds and a blister strip attached to a segment of said sheet.

2. A folded sheet product according to claim 1, in which the blister strip is located at or near a corner segment of the sheet.

3. A folded sheet product according to claim 1 or claim 2, in which the blister strip is attached to a segment of the sheet.

4. A folded sheet product according to claim 3, in which the blister strip is attached to a segment by an adhesive.

5. A folded sheet product according to claim 3 or claim 4, in which the blister strip comprises a cover sheet and a substrate, and the substrates of the blister strip is attached to the folded sheet.

6. A folded sheet product according to claim 3 or claim 4, in which the substrate of the blister strip is provided by a segment of the sheet.

7. A folded sheet product according to any one of claims 3 to 6, in which the segment of the sheet to which the blister strip is attached comprises perforations.

8. A folded sheet product according to any one of claims 3 to 9, in which the perforations correspond in location with the opening(s) of the indentation(s) of the cover sheet of the blister strip.

9. A folded sheet product according to claim 8 or claim 9, in which the perforations may be substantially X shaped.

10. A folded sheet product according to any one of claims 3 to 9, in which the segment of the sheet to which the blister strip is attached comprises one or more cut out sections.

11. A folded sheet product according to claim 10, in which one or more cut out sections correspond in location with the opening(s) of the indentation(s) of the cover sheet of the blister strip.

12. A folded sheet product according to any one of claims 7 to 11, in which one or more opening defined by the one or more perforations and/or cut out sections has or have dimensions which correspond substantially with the dimensions of the one or more openings of the indentations of the blister strip.

13. A folded sheet product according to any one of claims 7 to 12, in which a single cut out section and/or perforated region is provided for the or each indentation of the blister strip.

14. A folded sheet product according to any one of claims 7 to 12, in which a single cut out section and/or perforated region is provided for a plurality of indentations of the blister strip.

15. A folded sheet product according to any preceding claim, in which a folded sheet product in accordance with the present invention further comprises a stiff portion.

16. A folded sheet product according to claim 15, in which the stiff portion is attached to a segment of the folded sheet.

17. A folded sheet-product according to claim 15 or claim 16, in which the stiff portion is provided by the blister strip.

18. A folded sheet product according to any one of claims 15 to 17, in which the blister strip comprises a cover sheet and a substrate, and the substrate of the blister strip is attached to the stiff portion.

19. A folded sheet product according to any one of claims 15 to 19,; in which an edge of the stiff portion is attached to an edge of the blister strip.

20. A folded sheet product according to any one of claims 15 to 19, in which the stiff portion is substantially the same size and/or shape as the blister strip.

21. A folded sheet product according to any one of claims 15 to 20, in which the stiff portion and/or the blister strip have a marginal flange extending along a portion of the edge for attachment therebetween.

22. A folded, sheet product according to claim 21, in which the marginal flange extends from the stiff portion and is attached directly to the blister strip.

23. A folded sheet product according to claim 21, in which the marginal flange extends from the stiff portion and the marginal flange of the stiff portion is attached in directly to the blister strip.

24. A folded sheet product according to claim 21, in which the marginal flange extends from the blister strip and is attached directly to the stiff portion.

25. A folded sheet product according to claim 21, in which the marginal flange extends from the blister strip and the marginal flange of the blister strip is attached indirectly to the stiff portion.

26. A folded sheet product according to any one of claims 21 to 25, in which the marginal flange comprises a line of weakness extending along the length thereof to facilitate removal of the blister strip from the stiff portion.

27. A folded sheet product according to any one of claims 21 to 27, in which a fold line is provided between the marginal flange and the edge of the stiff portion and/or the edge of the blister strip from which it extends.

28. A folded sheet product according to any one of claims 21 to 27, in which the marginal flange is an extension of the stiff portion and/or the blister strip.

29. A folded sheet product according to claim 28, in which the marginal flange forms another stiff portion.

30. A folded-sheet product according to any one of claims 21 to 27, in which the marginal flange is provided by a tab which is attached to the edge of the stiff portion and/or the blister strip.

31. A folded sheet product according to any one of claims 15 to 30, in which the blister strip is arranged to lie flat against the stiff portion.

32. A folded sheet product according to claim 31, in which is an edge of the blister strip is attached to an edge of the stiff portion, and one or more of the free edges of the blister strip is fastened to a corresponding edge of the stiff portion by fastening means in order to maintain the blister strip folded against the stiff portion.

33. A folded sheet product according to claim 32, in which the fastening means temporarily fasten the one or more free edges of the blister strip against the stiff portion.

34. A folded sheet product according to claim 33, in which the fastening means is re-usable, so that the blister strip may be unfastened and then refastened in its folded condition against the stiff portion.

35. A folded sheet product according to claim 15, in which the marginal flange comprises a line of weakness to facilitate separation of an edge of the blister strip from the corresponding edge of the stiff portion.

36. A folded sheet product according to any one of claims 15 to 35, in which the blister strip is arranged relative to the stiff portion such that the cover sheet is adjacent the stiff portion or such that the substrate is adjacent the stiff portion.

37. A folded sheet product according to any one of claims 15 to 36, in which the stiff portion is located at or near a corner segment of the sheet.

38. A folded sheet product according to any one of claims 15 to 37, in which a stiff portion and a separate blister strip are located at substantially diagonally opposite corners of the sheet.

39. A folded sheet product according to any one of claims 15 to 38, in which the stiff portion comprises one or more folds dividing the stiff portion into separate stiff portion segments.

40. A folded sheet product according to claim 39, in which the one or more folds is or are parallel to an edge of the stiff portion.

41. A folded sheet product according to claim 39 or claim 40, in which the stiff portion comprises a plurality of folds, and the plurality are parallel to one another.

42. A folded sheet product according to claim 41, in which the plurality of folds form a spine when folded.

- 43.** A folded sheet product according to any one of claims 15 to 42, in which comprises a second stiff portion.
- 44.** A folded sheet product according to claim 43, in which the second stiff portion is located at or near a corner segment of the sheet.
- 45.** A folded sheet product according to claim 44, in which the second stiff portion is located at a segment of the sheet, which is diagonally opposite the segment at which the first stiff portion is located.
- 46.** A folded sheet product according to any one of claims 43 to 45, in which the second stiff, portion is provided by a second blister strip.
- 47.** A folded sheet product according to any one of claims 15 to 46, in which a stiff portion is provided by a segment of the sheet that has been treated to make it stiffer than the rest of the sheet.
- 48.** A folded sheet product according to any preceding claim, in which the blister strip provides an outside cover of the sheet when the sheet is in a folded condition.
- 49.** A folded sheet product according to, claim 46 or claim 47, or claim 48 when dependent on claim 46 or claim 47, in which comprises two stiff portions, both of the stiff portions provide a cover of the sheet when the sheet is in a folded condition.
- 50.** A folded sheet product according to claim 15, in which a stiff portion may comprise a fold such that a flap-over cover is provided for the folded sheet when in a folded condition.
- 51.** A folded sheet product according to claim 50, in which the cover comprises closure means to maintain the sheet folded.
- 52.** A folded sheet product according to any preceding claim, in which the first set of folds is a set of concertina folds.
- 53.** A folded sheet product according to claim 52, in which the first set of folds form the folded sheet into a single row of segments.
- 54.** A folded-sheet product according to claim 52 or claim 53, in which the folded sheet material further comprises a second set of folds, which second set of folds are transverse to said first set of folds when said sheet is in a folded condition.
- 55.** A folded sheet product according to claim 54, in which said second set of folds comprises a set of concertina folds.
- 56.** A folded sheet product according to claim 54 or claim 53, in which the second set of folds comprises an even number of folds.
- 57.** A folded sheet product, according to any preceding claim, in which the first set of folds comprises an odd number of folds.
- 58.** A folded sheet product according to any preceding claim, in which the folded sheet comprises a row of segments and the stiff portion is located at an end segment of the folded sheet.
- 59.** A folded sheet product according to claim 54, in which the stiff portion is suitably located at a corner segment of the folded sheet.
- 60.** A folded sheet product according to claim 15, in which the stiff portion is located at the outside of the sheet when it has been folded.
- 61.** A folded sheet product according to claim 15, in which a stiff portion comprises a first section and a second section for at least partly sandwiching the blister strip between the first section and the second section.
- 62.** A folded sheet product according to claim 61, in which the sections of the stiff portion are of substantially the same size.
- 63.** A folded sheet product according to claim 61 or claim 62, in which the first section of the stiff portion is at least as large as the segment of the sheet to which it is attached.
- 64.** A folded sheet product according to any one of claims 61 to 63, in which the second section of the stiff portion attaches the blister strip to the first section of the stiff portion.
- 65.** A folded sheet product according to any one of claims 61 to 64, in which the first and second sections are provided by a single element and are separated from one another by means of a fold line.
- 66.** A folded sheet product according to claim 15, in which the folded sheet is attached to one surface of the stiff portion and the blister strip is connected to another surface of the stiff portion.
- 67.** A folded sheet product according to any one of claims 61 to 66, in which the first and second section comprise a first stiff portion, and the product comprises a second stiff portion to which the folded sheet is attached.
- 68.** A folded sheet product according to claim 67, in which the second stiff portion is attached to the first section of the first stiff portion.
- 69.** A folded sheet product according to claim 67, in which the second stiff portion is attached to the second section of the first stiff portion.
- 70.** A folded sheet product according to any one of claims 67 to 69, in which the second stiff portion is separated from the first stiff portion by a further fold line.
- 71.** A folded sheet product according to any preceding claim, in which a cover portion is provided to cover the blister pack.
- 72.** A folded sheet product according to claim 71, in which the cover portion comprises a stiff portion.
- 73.** A folded sheet product according to claim 71 or claim 72, in which the folded sheet is provided at a first stiff portion, the blister pack is provided at a second stiff portion and the cover portion is a third, stiff portion.
- 74.** A folded sheet product according to claim 73, in which the stiff portions are foldably connected.
- 75.** A folded sheet product according to claim 74, in which the first stiff portion is between the second and third stiff portions whereby the second stiff portion can fold over the folded sheet and the third stiff portion can cover at least partly, the second stiff portion.
- 76.** A folded sheet product according to any one of claims 73 to 75, in which part of the third stiff portion is attached to the second portion.
- 77.** A folded sheet product according to claim 76, in which the part of the third portion attached to the second portion is releasably connected to another part of the third portion, whereby the blister pack can be accessed by separating the attached part of the third stiff portion from the rest of the third stiff portion.
- 78.** A folded sheet product according to any one of claims 73 to 77, in which a fastening means may be provided by a tongue and slot arrangement of the second and third stiff portions.
- 79.** A folded sheet product according to claim 78, in which the tongue is on the third stiff portion and the slot is on the second stiff portion.

**80.** A folded sheet product according to claim 78 or claim 79, when dependent on claim 77, in which the tongue is provided by removing the attached parts of third stiff portion from the rest.

**81.** A folded sheet product according to claim 61, in which the second section of the stiff portion suitably, comprises one or more openings therein.

**82.** A folded sheet product according to claim 81, in which the opening in the second section of the stiff portion is configured to receive indentations of a blister strip, when a blister strip is attached to the stiff portion.

**83.** A folded sheet product according to claim 81, in which the second section may comprise a plurality of openings each of a size suitable to receive one indentation of a blister strip.

**84.** A folded sheet product according to claim 61, in which the second section may comprise one or more openings of a size suitable to receive a plurality of indentations of a blister strip.

**85.** A folded sheet product according to claim 83 or claim 84, in which the openings in the second section of the stiff portion by have a shape that corresponds to the shape of the indentations of a blister strip.

**86.** A folded sheet product according to claim 81, in which the second section may provide one or more separators between the indentations of a blister strip.

**87.** A folded sheet product according to claim 86, in which the or each separator is configured to separate rows and/or columns of indentations of the blister strip.

**88.** A folded sheet product according to claim 71, in which, the first section comprises one or more cut out sections, which sections correspond in location with the openings of the indentations of the cover sheet of the blister strip when attached thereto.

**89.** A folded sheet product according to claim 88, in which the first section provides one or more separators between openings of the indentations of the blister strip.

**90.** A folded sheet product according to claim 88 or claim 89, in which the or each separator separates rows and/or columns of openings of the indentations of the blister strip.

**91.** A folded sheet product according to claim 71, in which a stiff portion comprises perforations.

**92.** A folded sheet product according to claim 91, in which the perforations correspond in location with the opening of the indentations of the cover sheet of the blister strip when attached thereto.

**93.** A folded sheet product according to claim 67, in which the stiff portion is provided with closure means, arranged to fasten the second stiff portion in a position wherein it is folded over the first stiff portion.

**94.** A folded sheet product comprising a folded sheet having at least a first set of folds, and a stiff portion at a segment of said sheet, in which the stiff portion comprises a tongue portion formable by removing at least one part of the stiff portion which part is separated from the tongue portion by a frangible region.

**95.** A folded sheet product according to claim 94, in which the frangible region is formed by a weakening of the stiff portion.

**96.** A folded sheet product according to claim 95, in which weakening is formed by perforations.

**97.** A folded sheet product comprising a folded sheet having a first, set of folds and a stiff portion forming a sealable cover about the folded sheet, which product further comprises a tamper evident feature.

**98.** A folded sheet product according to claim 97, in which the tamper evident feature comprises the cover being sealable whereby breaking the seal is visible.

**99.** A folded sheet product according to claim 97 or claim 98, in which part of the cover is separable from another part of the cover to open the product.

**100.** A folded sheet product according to any one of claims 97 to 99, in which a cover portion is provided to cover the blister pack.

**101.** A folded sheet product according to claim 100, in which the cover portion comprises a further stiff portion.

**102.** A folded sheet product according to any one of claims 97 to 101, in which the folded sheet is provided at a first stiff portion, the blister pack is provided at a second stiff portion and the cover portion is a third stiff portion.

**103.** A folded sheet product according to claim 102, in which the stiff portions are foldably connected.

**104.** A folded sheet product according to claim 103, in which the first stiff portion is between the second and third stiff portions whereby the second stiff portion can fold over the folded sheet and the third stiff portion can cover at least partly, the second stiff portion.

**105.** A folded sheet product according to any one of claims 102 to 104, in which part of the third portion is attached to the second portion.

**106.** A folded sheet product according to claim 105, in which the part of the third portion attached to the second portion is releasably connected to another part of the third portion.

**107.** A folded sheet product according to claim 106, in which by a perforation, whereby the blister pack can be accessed by separating the attached part of the third stiff portion from the rest of the third stiff portion.

\* \* \* \* \*