

(19) World Intellectual Property Organization
International Bureau



(43) International Publication Date
20 May 2010 (20.05.2010)

(10) International Publication Number
WO 2010/055087 A2

(51) International Patent Classification:
F25D 25/02 (2006.01)

(21) International Application Number:
PCT/EP2009/065043

(22) International Filing Date:
12 November 2009 (12.11.2009)

(25) Filing Language: English

(26) Publication Language: English

(30) Priority Data:
A 2008/08650 13 November 2008 (13.11.2008) TR

(71) Applicant (for all designated States except US): ARCE-
LIK ANONIM SIRKETI [TR/TR]; E5 Ankara Asfalti
Uzeri, Tuzla, 34950 Istanbul (TR).

(72) Inventors; and

(75) Inventors/Applicants (for US only): KAHRAMAN,
Soner [TR/TR]; E5 Ankara Asfalti Uzeri, Tuzla, 34950
Istanbul (TR). MOZA, Ahmet Onur [TR/TR]; E5
Ankara Asfalti Uzeri, Tuzla, 34950 Istanbul (TR).
OZSEKER, Gokhan [TR/TR]; E5 Ankara Asfalti Uzeri,

Tuzla, 34950 Istanbul (TR). OZTURK, Fatih Mehmet
[TR/TR]; E5 Ankara Asfalti Uzeri, Tuzla, 34950 Istanbul
(TR).

(81) Designated States (unless otherwise indicated, for every
kind of national protection available): AE, AG, AL, AM,
AO, AT, AU, AZ, BA, BB, BG, BH, BR, BW, BY, BZ,
CA, CH, CL, CN, CO, CR, CU, CZ, DE, DK, DM, DO,
DZ, EC, EE, EG, ES, FI, GB, GD, GE, GH, GM, GT,
HN, HR, HU, ID, IL, IN, IS, JP, KE, KG, KM, KN, KP,
KR, KZ, LA, LC, LK, LR, LS, LT, LU, LY, MA, MD,
ME, MG, MK, MN, MW, MX, MY, MZ, NA, NG, NI,
NO, NZ, OM, PE, PG, PH, PL, PT, RO, RS, RU, SC, SD,
SE, SG, SK, SL, SM, ST, SV, SY, TJ, TM, TN, TR, TT,
TZ, UA, UG, US, UZ, VC, VN, ZA, ZM, ZW.

(84) Designated States (unless otherwise indicated, for every
kind of regional protection available): ARIPO (BW, GH,
GM, KE, LS, MW, MZ, NA, SD, SL, SZ, TZ, UG, ZM,
ZW), Eurasian (AM, AZ, BY, KG, KZ, MD, RU, TJ,
TM), European (AT, BE, BG, CH, CY, CZ, DE, DK, EE,
ES, FI, FR, GB, GR, HR, HU, IE, IS, IT, LT, LU, LV,
MC, MK, MT, NL, NO, PL, PT, RO, SE, SI, SK, SM,

[Continued on next page]

(54) Title: A COOLING DEVICE COMPRISING A MOVABLE HOLDER

Figure 1

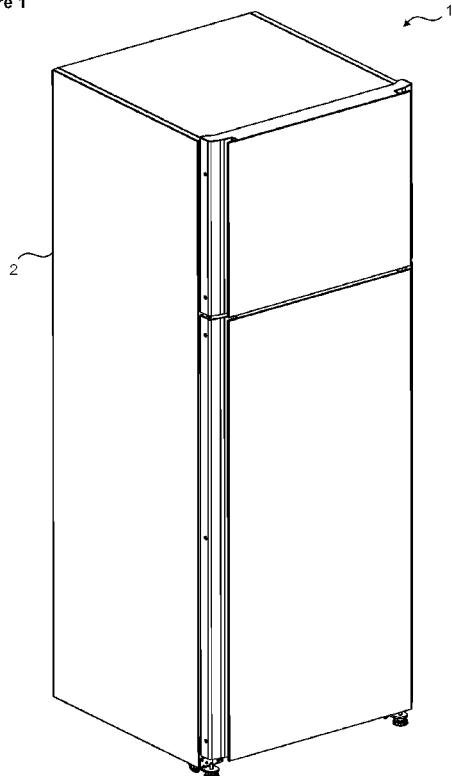

(57) Abstract: The cooling device (1) of the present invention comprises a body (2) wherein items to be cooled are stored, a door allowing access to the inside of the body (2) from the outer environment, one or more shelves positioned into the body (2) at different heights and a fixed holder (3) having at least two brackets (4) bent in "U"-shape which are mounted to the shelf and which are located in the same loading direction (X), and a connector (5) that connects these brackets (4) to each other.



WO 2010/055087 A2

TR), OAPI (BF, BJ, CF, CG, CI, CM, GA, GN, GQ, GW, ML, MR, NE, SN, TD, TG). **Published:**

— *without international search report and to be republished upon receipt of that report (Rule 48.2(g))*

Description**A COOLING DEVICE COMPRISING A MOVABLE HOLDER**

- [0001] The present invention relates to a cooling device comprising holders that occupy less volume and provide bottles to be carried and stored.
- [0002] Various solutions are developed in order that bottles can be stored horizontally in the inner volume of the body without occupying much space. In the state of the art, bottle holders of various structures positioned on top of or under the shelves that divide the inner volume of the body into partitions are located.
- [0003] In the state of the art European Patent No EP0917639, a storage device for stocking bottles and which is folded under the shelf for occupying less space when not used is explained.
- [0004] Another state of the art document is the International Patent Application No WO05059458. In this patent application, one or more bottle carriers are explained providing one bottle to be stored when they are aligned at the same level such that their horizontal or vertical axes intercept, and when not aligned at the same level, enabling more than one bottle to be stored.
- [0005] Another state of the art embodiment is explained in the International Patent Application No WO2008015188. Also in this embodiment, a bottle holder is explained which is mounted onto the shelf from a single point such that it will rotate around this point and which provides bottles of various dimensions to be carried.
- [0006] Another state of the art embodiment is explained in the Korean Patent Application No KR1020000050485. In this application, a bottle holder is explained which comprises brackets being brought to the closed position by being folded onto each other by being connected such that they will rotate around the axis whereon they are mounted to each other, and the usage volume of which can be changed.
- [0007] The aim of the present invention is the realization of a cooling device comprising a movable holder that occupies less volume when not used and provides bottles to be carried and stored in a safe way.
- [0008] The cooling device realized in order to attain the aim of the present invention, explicated in the first claim and the respective claims thereof,

comprises a movable holder which is fixed to the fixed holder, which allows only one bottle to be loaded thereon when it is in the closed position wherein it is folded on the fixed holder to be carried, and when it is brought to the opened position by being rotated 180 degrees and translated, provides also a second bottle to be carried by creating an additional loading volume next to the fixed holder.

- [0009] The movable holder comprises movable brackets that are fastened to the brackets and a movable connector that connects the movable brackets arranged at intervals to each other and thus, provides the movable brackets to move together.
- [0010] Thus, the movable holder does not occupy unnecessary volume inside the body when not used.
- [0011] The movable bracket comprises an extension that is formed by the arm wherefrom the movable bracket is connected to the bracket being bent to the outside such that it will remain in the same plane. The extension remains outside the loading volume, the boundaries of which are formed by the movable bracket, and the movable connector is connected to each movable bracket through these extensions. While the movable holder passes from the opened position to the closed position or from the closed position to the opened position, the movable connector constantly moves outside the loading volume of the movable holder and depending on the movable holder.
- [0012] The movable bracket located in the forefront of the movable holder comprises an extension on the arm mounted to the bracket and a handle formed by the other arm being bent towards the outside such that the handle will remain in the same plane with the extension. While the movable connector is connected to the extension, the handle enables the user to activate the movable holder by triggering the bracket in the front and thus, to change the position of the movable holder.
- [0013] The fixed holder and the movable holder are mounted by the brackets and the movable brackets being connected to each other by means of connecting elements that comprise two "C"-shaped housings such that their backs will bear against each other.

- [0014] The movable connector is mounted to the movable holder by means of a joint.
- [0015] The joint comprises a first bearing which moves together with the movable bracket and which comprises a first housing that extends in the horizontal plane and wherein the extension is mounted by bearing, and a second housing that extends vertically to the first housing and wherein one end of the pin is seated freely.
- [0016] The joint, furthermore, comprises a second bearing which moves together with the movable connector and which comprises a first housing that extends in the horizontal plane and wherein the movable connector is mounted by bearing, and a second housing that extends vertically to the first housing and wherein the other end of the pin is seated freely.
- [0017] The length of the movable brackets is longer than the length of the brackets to which they are connected. Thus, by a level difference being created between the arms of the brackets connected to each other, the movable brackets that have a protrusion formed towards the outside of the loading volume due to the extension are enabled to rotate around the brackets easily and when the movable holder comes to the fully opened position, also the movable connector is provided to partially pass into the loading volume of the fixed holder due to this level difference.
- [0018] By means of the present invention, a movable holder consisting of movable brackets that are connected to each other by a movable connector is provided to pass to the closed position by being folded onto a fixed holder consisting of brackets that are arranged at certain intervals and that are, again, connected to each other by a connector. Thus, when the movable holder is in the opened position, a carrying volume in addition to the fixed holder is created, and in the closed position, the movable holder is prevented from unnecessarily occupying volume when not used.
- [0019] A cooling device realized in order to attain the aim of the present invention is illustrated in the attached figures, where:
- [0020] Figure 1 – is the perspective view of a cooling device.
- [0021] Figure 2 – is the exploded view of a fixed and a movable holder.
- [0022] Figure 3 – is the perspective view of the movable holder and the fixed

holder in the closed position.

[0023] Figure 4 – is the view of detail A in Figure 3.

[0024] Figure 5 – is the exploded view of a joint.

[0025] Figure 6 - is the perspective view of the movable holder and the fixed holder in a phase while passing to the opened position.

[0026] Figure 7 - is the perspective view of the movable holder and the fixed holder in another phase while passing to the opened position.

[0027] Figure 8 – is the perspective view of the movable holder and the fixed holder in the opened position.

[0028] The elements illustrated in the figures are numbered as follows:

1. Cooling device
2. Body
3. Fixed holder
4. Bracket
5. Connector
6. Movable holder
7. Movable bracket
8. Movable connector
9. Extension
10. Handle
11. Connecting element
12. Housing
13. First bearing
14. Second bearing
15. , 115. First housing
16. , 116. Second housing
17. Pin
18. Joint

[0029] The cooling device (1) of the present invention comprises a body (2) wherein items to be cooled are stored (Figure 1), a door allowing access to the inside of the body (2) from the outer environment, one or more shelves positioned into the body (2) at different heights and a fixed holder (3) having at least two brackets (4) bent in “U”-shape which are mounted to

the shelf and which are located in the same loading direction (X), and a connector (5) that connects these brackets (4) to each other.

[0030] The cooling device (1), furthermore, comprises a movable holder (6) which has movable brackets (7) bent in "U"-shape, fastened pivotably to an arm of each bracket (4) such that it will rotate around that arm in the vertical axis and be translated, located in the same loading direction with the brackets (4) while in the closed position, creating an additional loading volume next to the fixed holder (3) when being brought to the opened position by being rotated 180 degrees in the horizontal plane and translated, and which has a movable connector (8) connecting the movable brackets (7) to each other through the arms wherefrom they are connected to the brackets (4) and thus, providing the movable brackets (7) to move together (Figure 2).

[0031] Thus, the movable brackets (7) that are connected to the brackets (4) arranged at intervals can easily enter between the brackets (4) and be folded onto the brackets (4) to which they are connected. Therefore, when required, the movable holder (6) is brought to the closed position such that it will occupy least volume in the body (2) by being folded onto the fixed holder (3). In this situation, the loading direction (Y) of the movable holder (6) and the loading direction (X) of the fixed holder (3) overlap. In this position, only one bottle can be carried on the fixed and the movable holders (3 and 6). When the movable holder (6) is brought to the opened position, two bottles can be easily carried both on the fixed holder (3) and on the movable holder (6) that is right next to the fixed holder (3). In this situation, the movable brackets (7) on the movable holder (6) are located in the same loading direction (Y) and both loading directions (X and Y) are parallel to each other. Thus, the movable holder (6) does not occupy unnecessary volume inside the body (2) when not used.

[0032] The movable bracket (7) comprises at least one extension (9) that is formed by the arm wherefrom the movable bracket (7) is connected to the bracket (4) being bent such that the arm will remain in the same plane with the movable bracket (7). The extension (9) remains outside the loading volume, the boundaries of which are formed by the movable bracket (7),

and the movable connector (8) is connected to each movable bracket (7) through these extensions (9). By means of this extension (9), the rotational movement around the arm wherefrom the movable brackets (7) are connected to the brackets (4) is transmitted to the movable connector (8) and the movable connector (8) performs an arc movement such that its direction will be parallel to the loading direction without changing. While the movable holder (6) passes from the opened position to the closed position or from the closed position to the opened position, the movable connector (8) constantly moves outside the loading volume of the movable holder (6) depending on the movable holder (6).

[0033] The movable bracket (7) located in the forefront of the movable holder (6) has an extension (9) on the arm mounted to the bracket (4) and a handle (10) formed by the other arm being bent such that the handle (10) will remain in the same plane with the extension (9). In this situation, the movable bracket (7) is shaped as an upside-down "Ω". The movable connector (8) is fastened to the extension (9) as in the above explained manner, and the handle (10) provides the user to easily hold and activate the movable bracket (7) and hence the movable holder (6).

[0034] The length of the movable bracket (7) is longer than the length of the bracket (4) to which it is connected, excluding the foremost and the backmost brackets (4). Thus, by means of the level difference between the arms of the movable bracket (7) and of the bracket (4) that are connected to each other, the movable connector (8) mounted to the extensions (9) of the movable brackets (7) is enabled to move by performing a 180 degree arc movement around the brackets (4). Furthermore, when the movable bracket (7) rotating around the arm wherefrom it is connected to the bracket (4) completely comes to the opened position, the movable connector (8) exiting out of the loading volume of the movable holder (6), thus, partially enters the loading volume of the fixed holder (3) and hence the movement is completed.

[0035] The movable connector (8) remains out of the volume bordered by the fixed holder (3) when the movable holder (6) is in the closed position, and remains at least partially in the volume bordered by the fixed holder (3)

when the movable holder (6) is in the opened position.

[0036] The cooling device (1) comprises a connecting element (11) that connects the fixed holder (3) and the movable holder (6) to each other and that has two "C"-shaped housings (12), the backs of which face each other, and into one of which the end of the bracket (4) and into the other the arm of the movable bracket (7) is seated. The movable bracket (7) is mounted to the bracket (4) by means of the connecting element (11) and the connecting element (11) rotates around the arm of the bracket (4). When the movable bracket (7) is activated by the user, the connecting element (11) and the movable bracket (7) connected thereto rotate around the rotational axis formed by the arm of the fixed holder (3) and, at the same time, are translated. Since the connecting element (11) moves during the rotational movement, the movable brackets (7) located in front of the brackets (4) while in the closed position pass to the back of the brackets (4) when the movable holder (6) passes to the opened position. Thus, the movable holder (6) is translated back and forth in the horizontal axis by means of the connecting element (11) through which the movable holder (6) is connected to the fixed holder (3).

[0037] The cooling device (1), furthermore, comprises a joint (18) having a first bearing (13) which is mounted to the extension (9) and moves together with the movable bracket (7), a second bearing (14) which is mounted to the movable connector (8) and moves together with the movable connector (8), and which is positioned on top of the first bearing (13), and a pin (17) which articulately connects the first and the second bearing (13 and 14) to each other and transmits the movement of the movable bracket (7) to the movable connector (8), and which provides the bearings (13 and 14) being one over the other to move in alignment and coaxially. The first bearing (13) does not move according to the extension (9) and the second bearing (14) does not move according to the movable connector (8), however, the first and the second bearing (13 and 14) move according to each other by means of the pin (17). The pin (17) only forms a rotational axis and stands freely in both bearings (13 and 14).

[0038] The first bearing (13) comprises a first housing (15) which extends in the

horizontal plane and wherein the extension (9) is borne, and a second housing (16) which extends vertically to the first housing (15). The second bearing (14) comprises a first housing (115) which extends in the horizontal plane and wherein the movable connector (8) is borne, and a second housing (116) which extends vertically to the first housing (115). The second housings (16 and 116) on both bearings (13 and 14), which are connected to each other by means of the pin (17), are located in the same direction and coaxial with the pin (17) (Figure 4 and Figure 5).

[0039] The fixed holder (3) is fixed by being mounted to the shelf by the foremost and the backmost brackets (4). The movable brackets (7) are mounted to the brackets (4) on the fixed holder (3) by means of the connecting element (11). In one of the two adjacent housings (12) on the connecting element (11), one arm of the bracket (4) and in the other one, one arm of the movable bracket (7) is borne. The connection between the movable holder (6) and the fixed holder (3) is hence provided.

[0040] The movable connector (8) is mounted onto the movable holder (6) by means of the joint (18). To the extension (9) provided by the arm wherefrom the movable brackets (7) are mounted to the brackets (4) being bent, the first bearing (13) is mounted. In this situation, while the extension (9) is borne in the first housing (15), one end of the pin (17) enters the second housing (16). Similarly, the second bearing (14) is mounted to the movable connector (8). In this situation, by mounting the movable connector (8) to the first housing (115) and the other end of the same pin (17) to the second housing (116) such that it will enter therein, the assembly of the movable connector (8) to the movable holder (6) by means of the joint (18) is completed.

[0041] When the movable holder (6) is in the closed position, it is located in the same loading direction (X and Y) with the fixed holder (3). This allows a bottle that is located on the bracket (4) or on the movable brackets (7) folded onto the brackets (4) to be carried (Figure 3).

[0042] When the movable holder (6) is desired to be passed to the opened position from the closed position, the user applies a force to the handle (10) on the movable bracket (7) in front of the movable holder (6). As a

result of this force, the movable bracket (7) starts rotating around the vertical axis in the housing (12) on the connecting element (11), through which it is connected to the bracket (4) (Figure 6 and Figure 7). While the movable bracket (7) rotates around the vertical axis, the extension (9) and the first bearing (13) fixed thereto are also translated together with the movable bracket (7). This translatory movement is transmitted to the movable connector (8) by means of the pin (17), one end of which is seated into the second housing (16) on the first bearing (13). In this situation, by the movable connector (8) performing the same movement with the extension (9), the movement of the movable bracket (7) in the front is transmitted simultaneously to all movable brackets (7) connected to the movable connector (8) by means of the movable connector (8). When the movable bracket (7) is rotated with an angle of 180 degrees by the user, it both rotates and is translated by means of the connecting element (11). As a result of this movement, all movable brackets (7) that are folded onto the brackets (4) in the closed position pass to the back of the brackets (4) and stand as one being in front of the other such that there will be a distance almost as much as the wall thickness of the bracket (4) between them and the brackets (4) and thus, create an additional carrying volume (Figure 8). In this situation, although the loading directions (X and Y) of the movable holder (6) and the fixed holder (3) standing side by side are parallel to each other, the movable brackets (7) and the brackets (4) do not stand in alignment and a distance as much as the wall thickness of the brackets (4 and 7) is present between them. Thus, both the fixed holder (3) and the movable holder (6) are brought to a position wherein they can carry one bottle each.

[0043] The bracket (4), the movable bracket (7), the connector (5) and the movable connector (8) are produced from wire.

[0044] By means of the present invention, a movable holder (6) consisting of movable brackets (7) that are connected to each other by a movable connector (8) is provided to pass to the closed position by being folded onto a fixed holder (3) consisting of brackets (4) that are arranged at certain intervals and that are, again, connected to each other by a

connector (5). Thus, when the movable holder (6) is in the opened position, a carrying volume in addition to the fixed holder (3) is created, and in the closed position, the movable holder is prevented from unnecessarily occupying volume when not used.

[0045] It is to be understood that the said present invention is not limited to the embodiments disclosed above and an expert in the technique can easily introduce different embodiments. These different embodiments should be considered within the scope of the claims of the present invention, too.

Claims

1. A cooling device (1) comprising a body (2) wherein items to be cooled are stored, a door that allows access to the inside of the body (2) from the outer environment, one or more shelves that are positioned into the body (2) at different heights and a fixed holder (3) that has at least two brackets (4) bent in "U"-shape which are mounted to the shelf and which are located in the same loading direction (X), and a connector (5) which connects these brackets (4) to each other, **characterized by** a movable holder (6) which has movable brackets (7) bent in "U"-shape, fastened pivotably to an arm of each bracket (4) such that it will rotate around that arm in the vertical axis and be translated, located in the same loading direction with the brackets (4) while in the closed position, creating an additional loading volume next to the fixed holder (3) when being brought to the opened position by being rotated 180 degrees in the horizontal plane and translated, and which has a movable connector (8) connecting the movable brackets (7) to each other through the arms wherefrom they are connected to the brackets (4) and thus, providing the movable brackets (7) to move together.
2. A cooling device (1) as in Claim 1, characterized by the movable bracket (7) which comprises an extension (9) that is formed by the arm wherefrom the movable bracket (7) is connected to the bracket (4) being bent such that the arm will remain in the same plane.
3. A cooling device (1) as in Claim 2, characterized by the movable bracket (7) shaped as an upside-down "Ω", located in the forefront of the movable holder (6), having an extension (9) on the arm mounted to the bracket (4) and a handle (10) formed by the other arm being bent such that the handle (10) will remain in the same plane with the extension (9).
4. A cooling device (1) as in any one of the above Claims, characterized by the movable connector (8) which remains out of the volume bordered by the fixed holder (3) while in the closed position, and which remains at least partially in the volume bordered by the fixed holder (3) while in the opened position.
5. A cooling device (1) as in any one of the above Claims, characterized by a connecting element (11) that has two "C"-shaped housings (12), the backs of which face each other, and into one of which the end of the bracket (4) on the

fixed holder (3) and into the other the arm of the movable bracket (7) on the movable holder (6) is seated, and that connects the fixed holder (3) and the movable holder (6) to each other.

6. A cooling device (1) as in any one of the Claims 2 to 5, characterized by the joint (18) having a first bearing (13) which is mounted to the extension (9) and moves together with the movable bracket (7), a second bearing (14) which is mounted to the movable connector (8) and moves together with the movable connector (8), and which is positioned on top of the first bearing (13), and a pin (17) which articulately connects the first and the second bearing (13 and 14) to each other and transmits the movement of the movable bracket (7) to the movable connector (8), and which provides the first and the second bearing (13 and 14) being one over the other to move in alignment and coaxially.
7. A cooling device (1) as in Claim 6, characterized by the first bearing (13) that comprises a first housing (15), which extends in the horizontal plane and wherein the extension (9) is borne, and a second housing (16) which extends vertically to the first housing (15).
8. A cooling device (1) as in Claim 6 or 7, characterized by the second bearing (14) that comprises a first housing (115), which extends in the horizontal plane and wherein the movable connector (8) is borne, and a second housing (116) which extends vertically to the first housing (115).
9. A cooling device (1) as in any one of the above Claims, characterized by the fixed holder (3) that is mounted to the shelf by the foremost and the backmost brackets (4).
10. A cooling device (1) as in any one of the above Claims, characterized by the movable bracket (7), the length of which is longer than the length of the bracket (4) to which it is connected.
11. A cooling device (1) as in any one of the above Claims, characterized by the bracket (4), the movable bracket (7), the connector (5) and the movable connector (8), each of which is produced from wire.

Figure 1

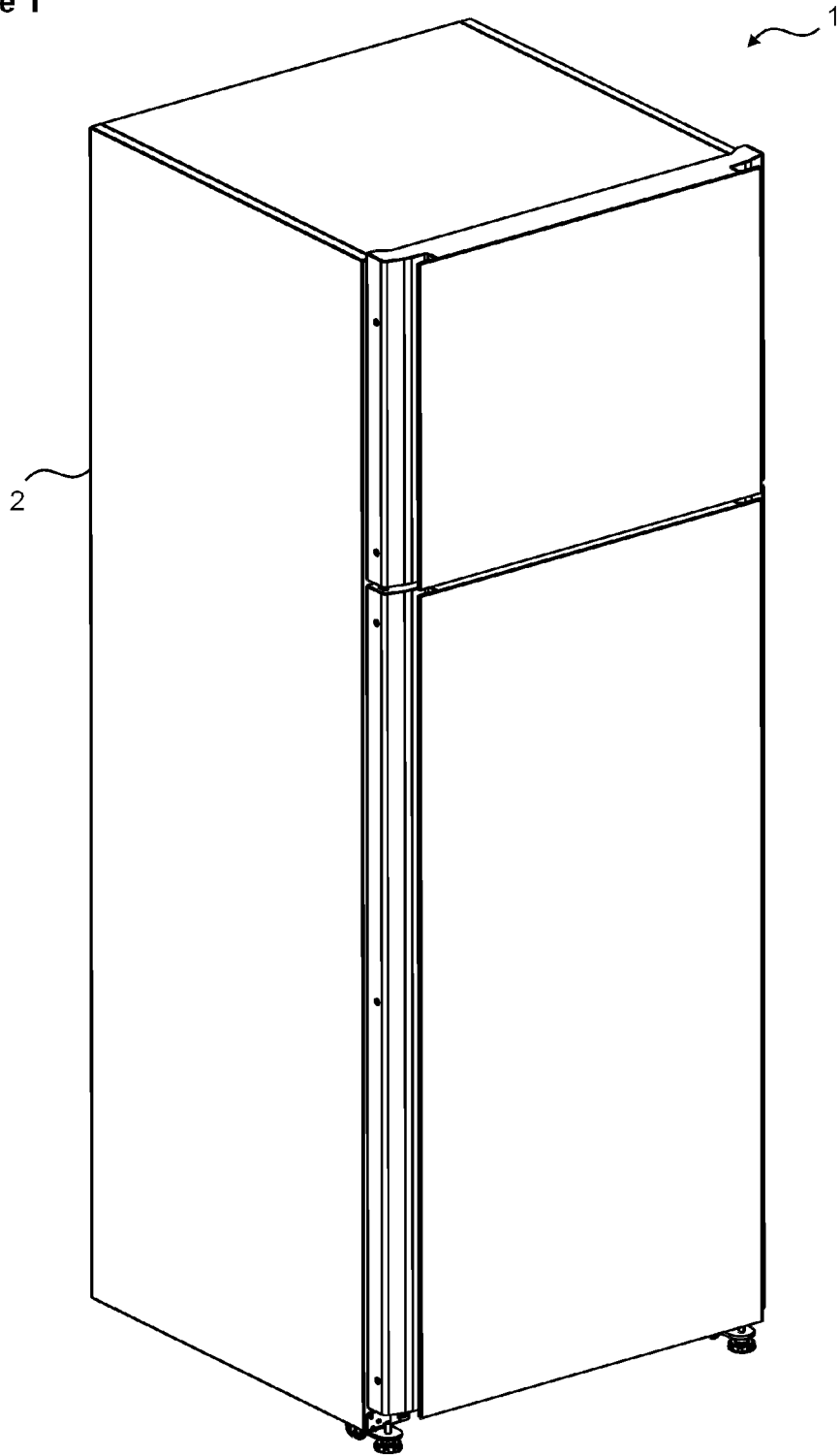

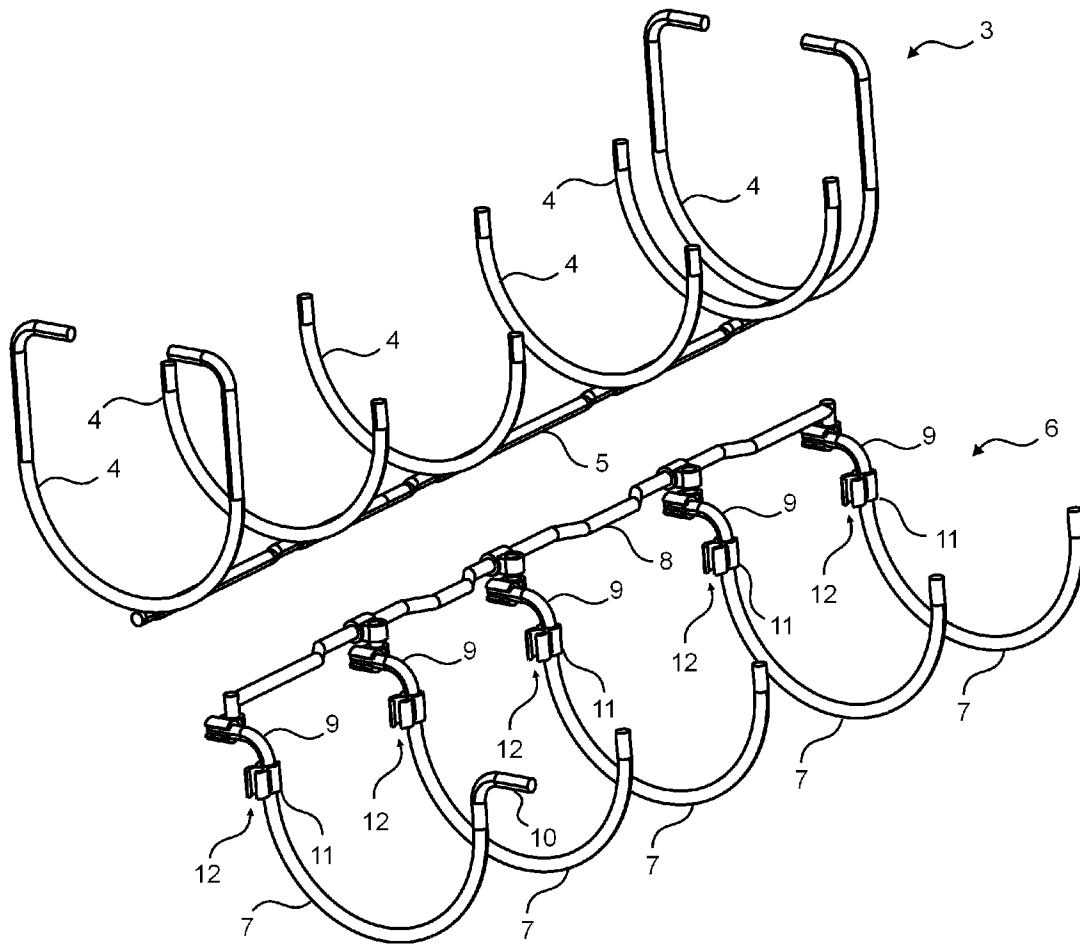

Figure 2

Figure 3

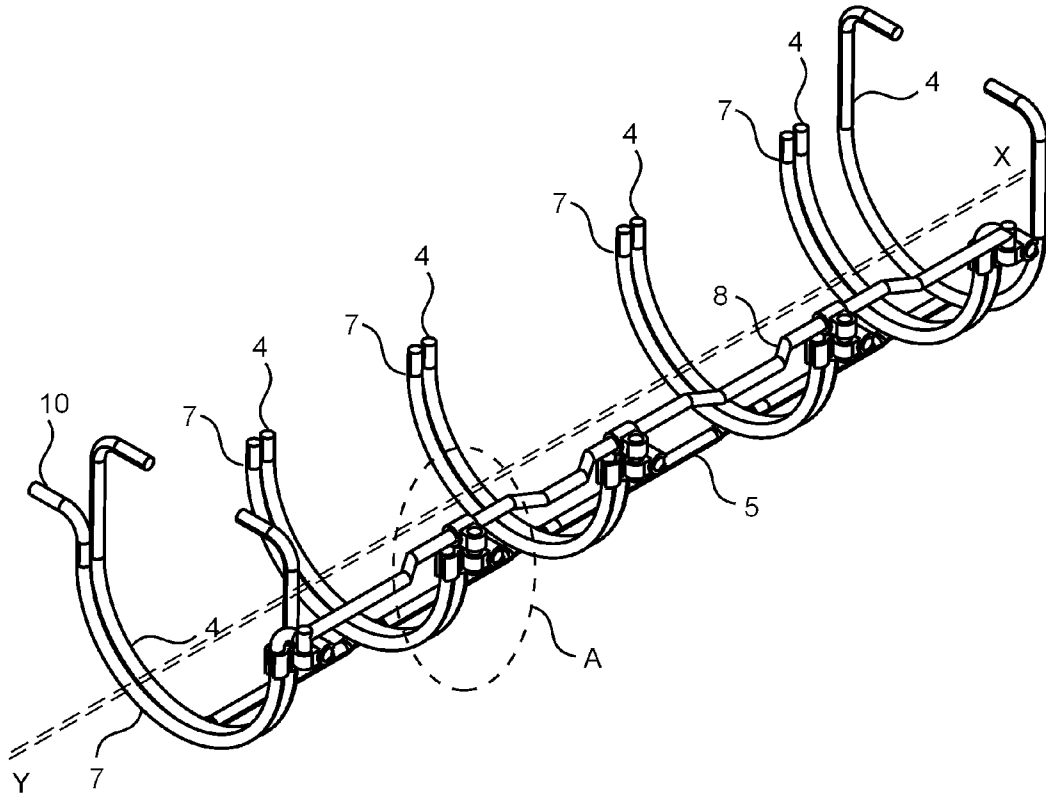

Figure 4

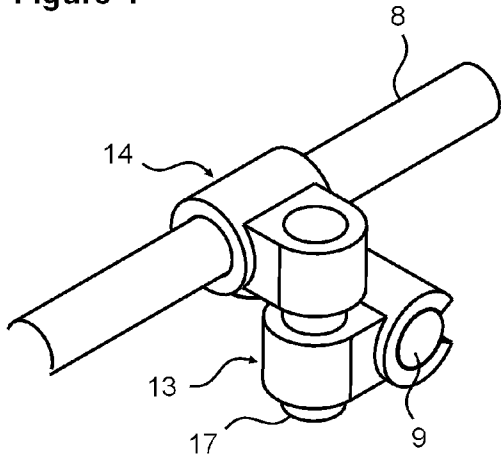

Figure 5

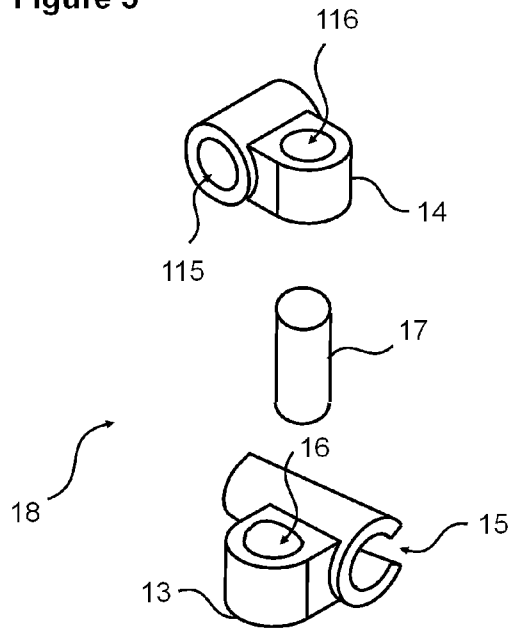

Figure 6

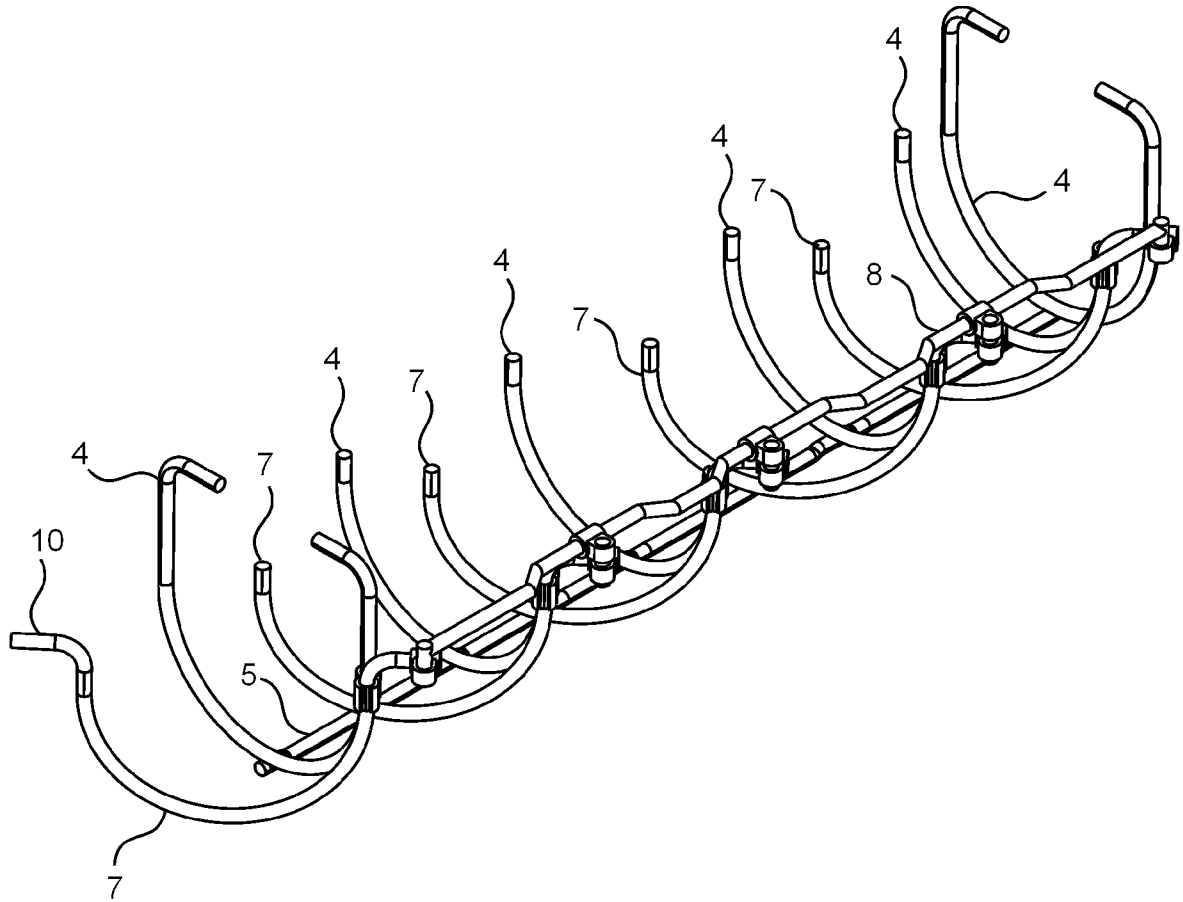

Figure 8

