



US 20070163673A1

(19) **United States**

(12) **Patent Application Publication**
Källberg

(10) **Pub. No.: US 2007/0163673 A1**

(43) **Pub. Date: Jul. 19, 2007**

(54) **USE OF A METHOD AND A SYSTEM FOR SPILL-FREE REFILLING OF LIQUIDS, GUN FOR SPILL-FREE REFILLING OF LIQUIDS, CONNECTION FOR A TANK, METHOD AND SYSTEM FOR CONTROL AND COMMUNICATION IN A SPILL-FREE LIQUID REFILLING SYSTEM, METHOD AND SYSTEM FOR MEDIA PROVISION IN A SPILL-FREE REFILLING SYSTEM, SPILL-FREE AND LIQUID-TIGHT REFILL**

(30) **Foreign Application Priority Data**

Jan. 19, 2004 (SE)..... 0400105-3

Publication Classification

(51) **Int. Cl.**
B65B 1/04 (2006.01)

(52) **U.S. Cl.** **141/383**

(75) **Inventor: Sylvid Källberg, Vallentuna (SE)**

Correspondence Address:
YOUNG & THOMPSON
745 SOUTH 23RD STREET
2ND FLOOR
ARLINGTON, VA 22202 (US)

(57) **ABSTRACT**

Method for spill-free refilling for a liquid solution selective catalytic reduction, SCR, an exhaust after-treatment technology for diesel engines. The method includes the steps of establishing a liquid-tight connection between a coupling part of a tank (37), and a coupling part of a dispensing nozzle of a gun (9) for spill-free refilling. A system for spill-free refilling of liquids and a gun for spill-free refilling of liquids, a connection for a vehicle tank, a method and a system for control and communication in a spill-free liquid re-filling system, a method and a system for media provision in a spill-free refilling system, a spill-free and liquid-tight refilling connection and computer programme products are disclosed.

(73) **Assignee: IDENTIC AB, Vallentuna (SE)**

(21) **Appl. No.: 10/586,364**

(22) **PCT Filed: Nov. 3, 2004**

(86) **PCT No.: PCT/SE04/01604**

§ 371(c)(1),
(2), (4) **Date: Sep. 6, 2006**

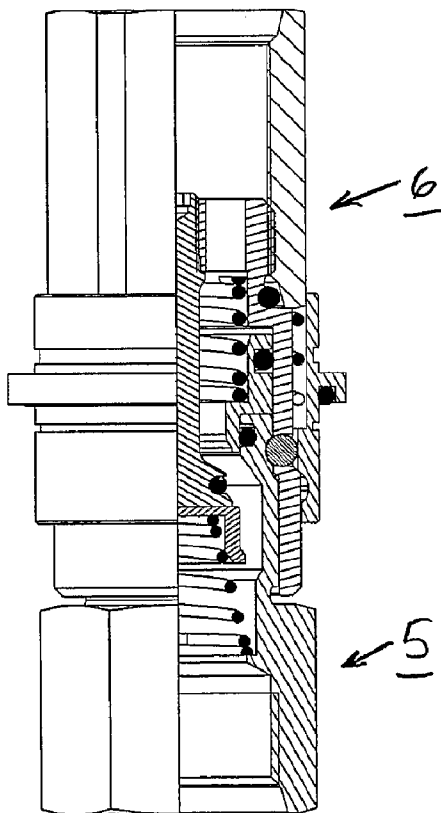

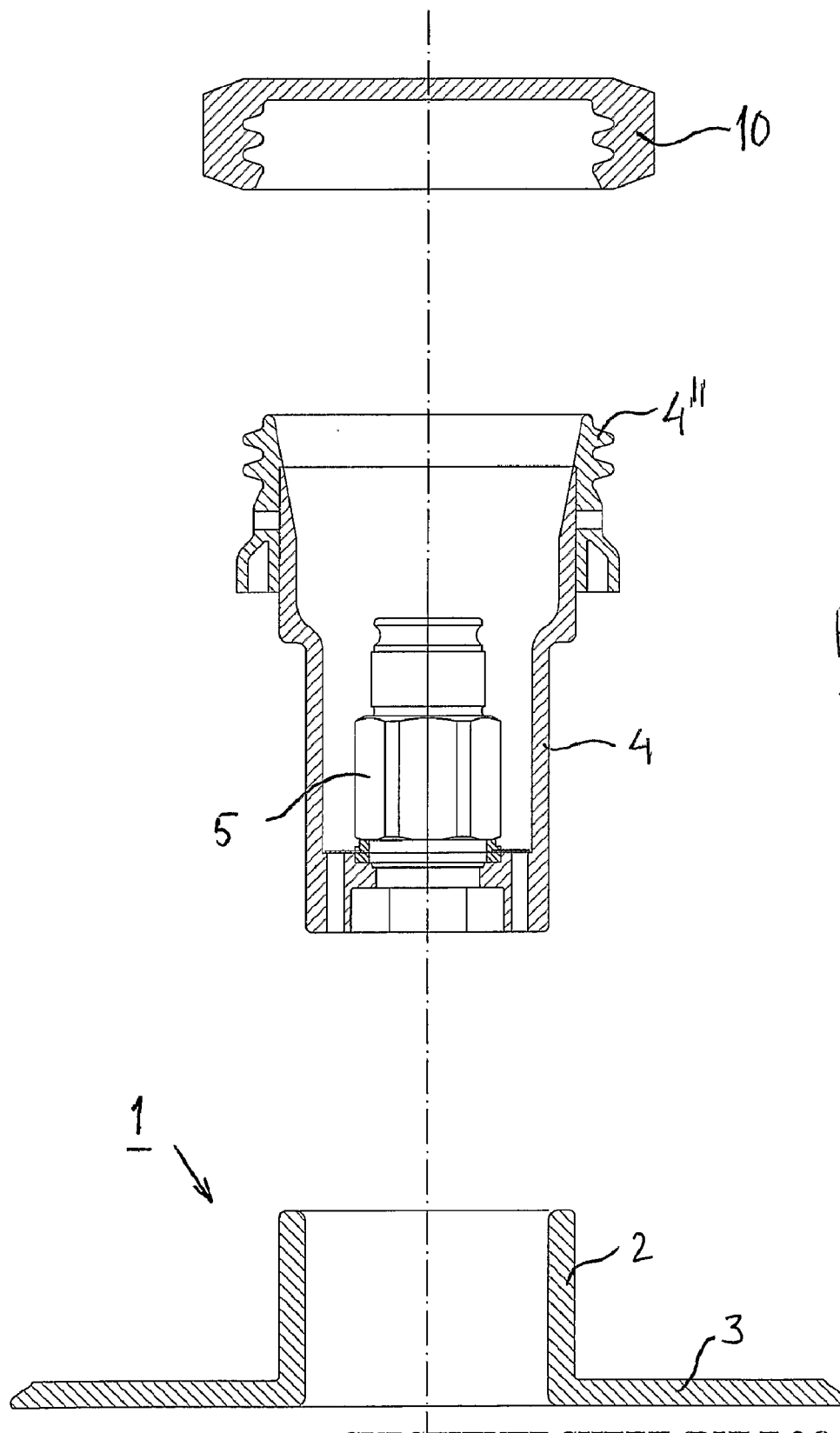

Fig. 1

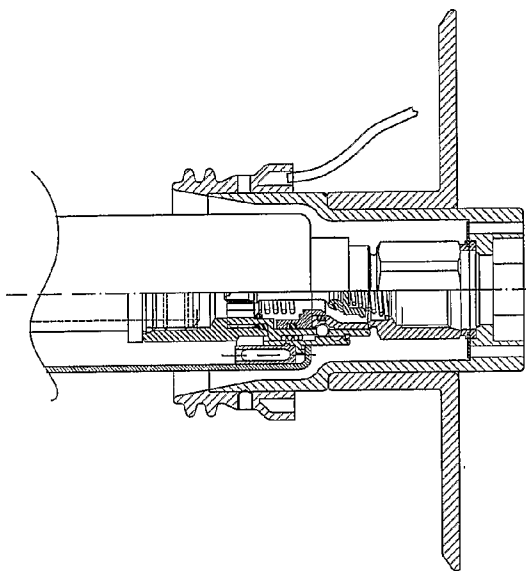

Fig. 2b

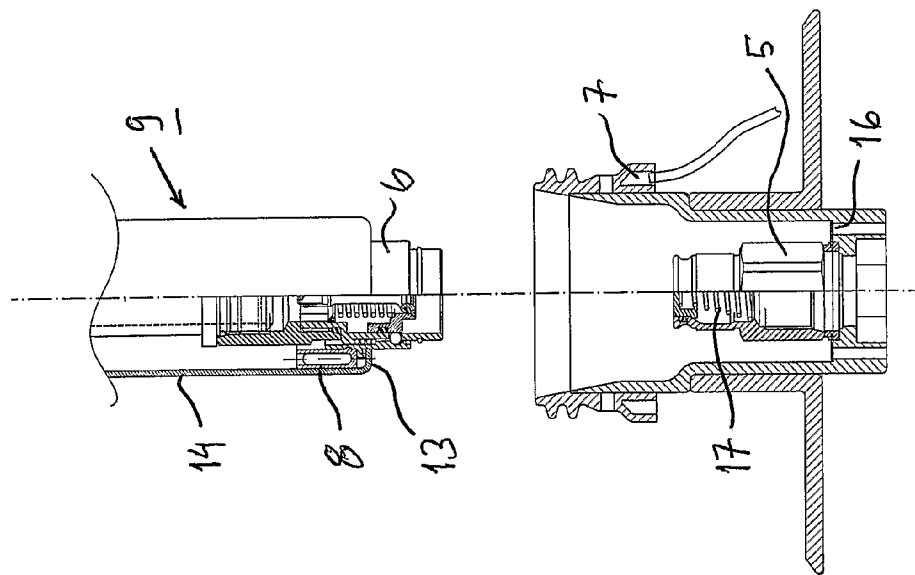
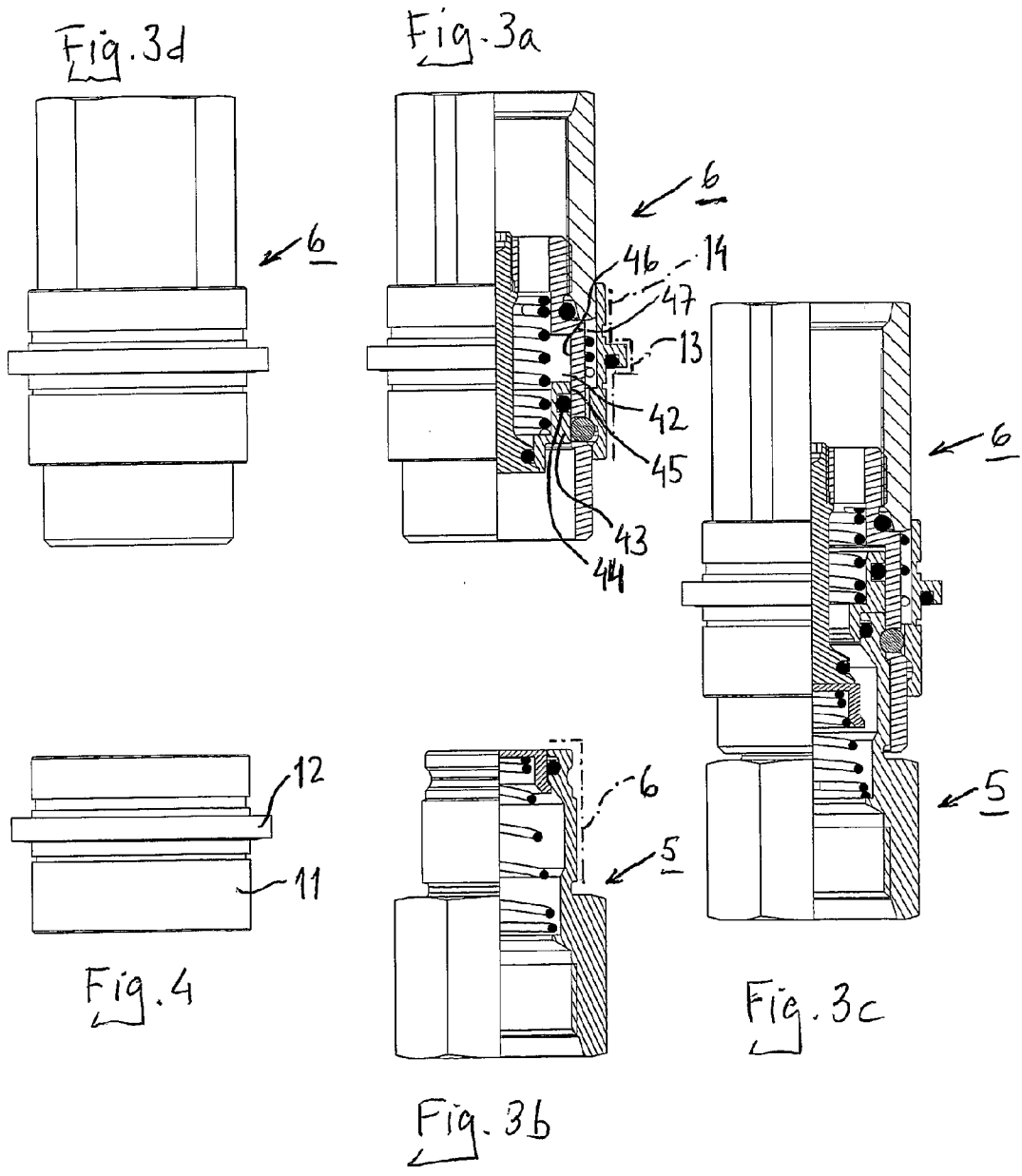

Fig. 2a



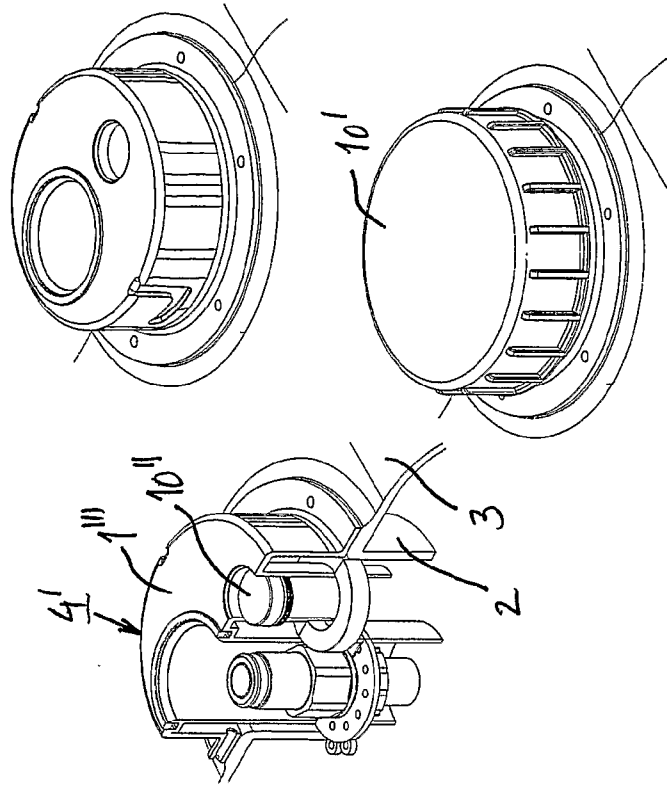

Fig. 5b

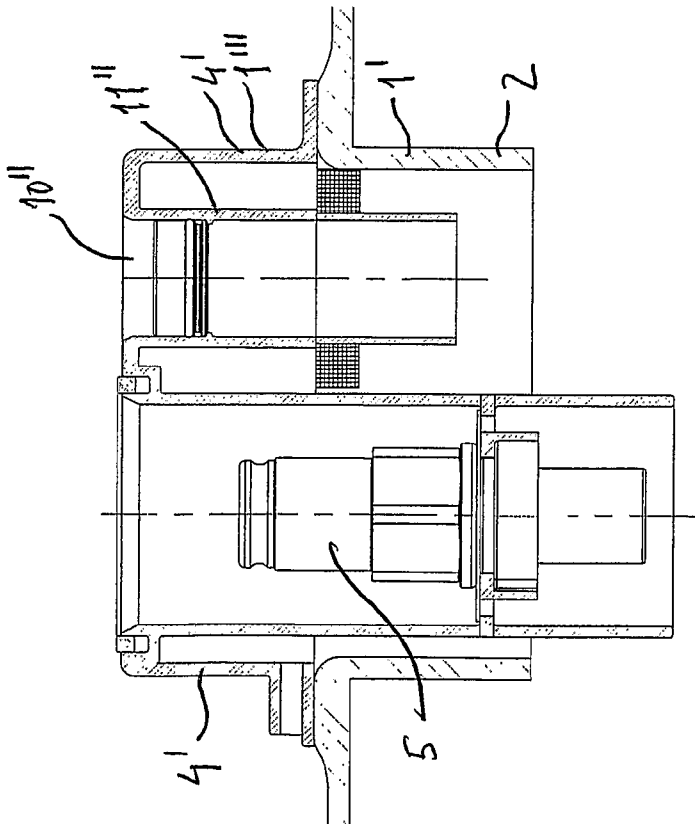
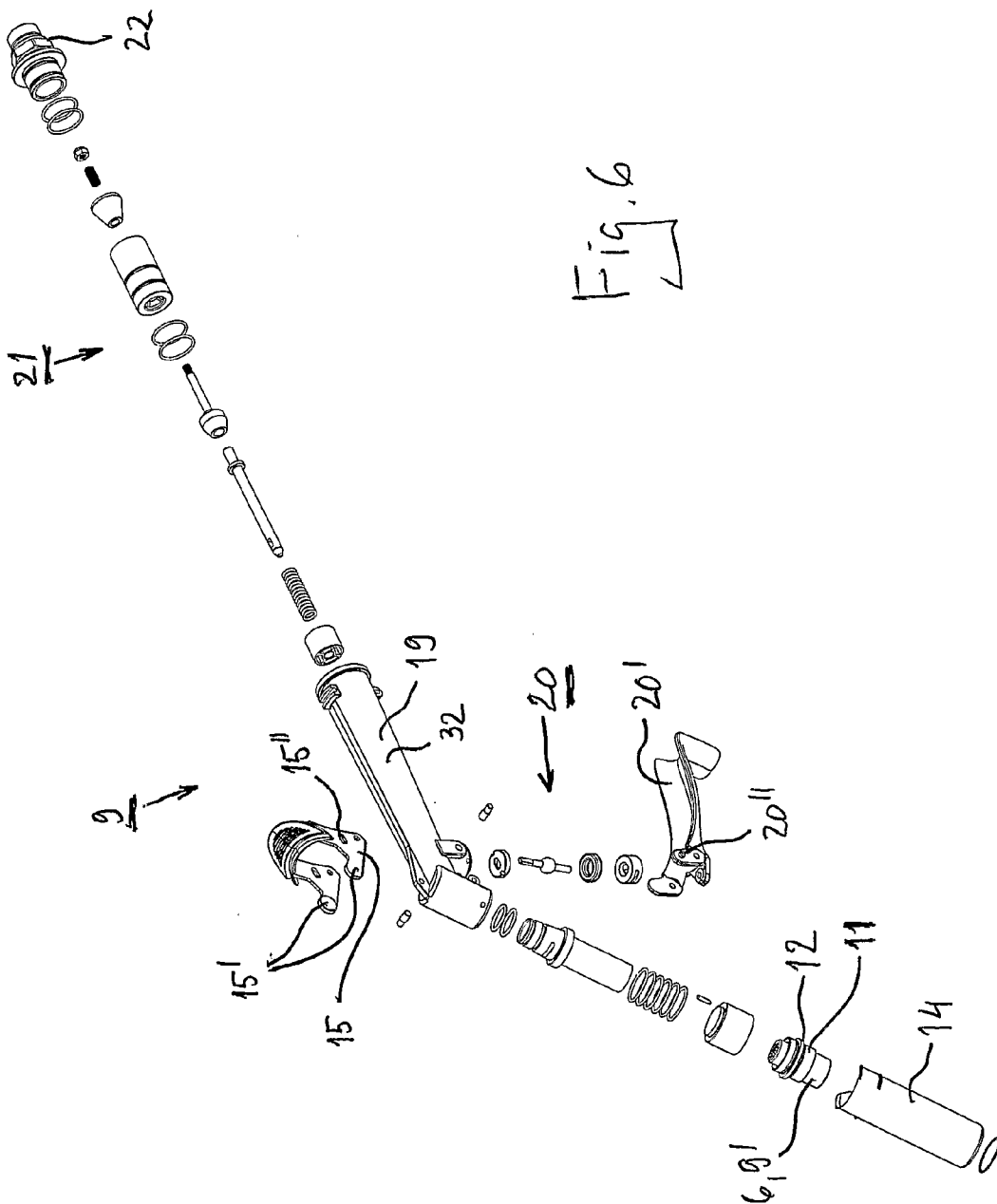

Fig. 5a



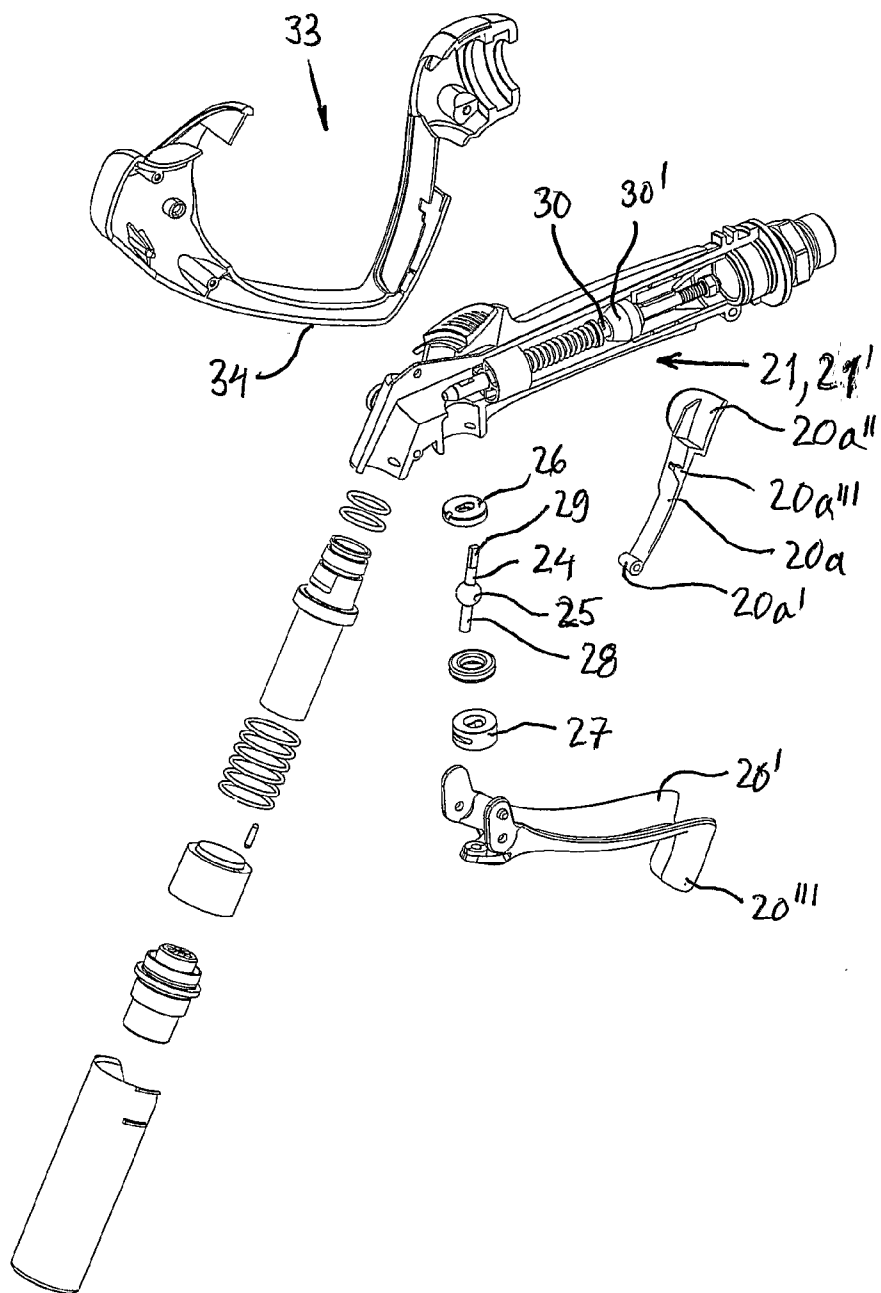

Fig. 7

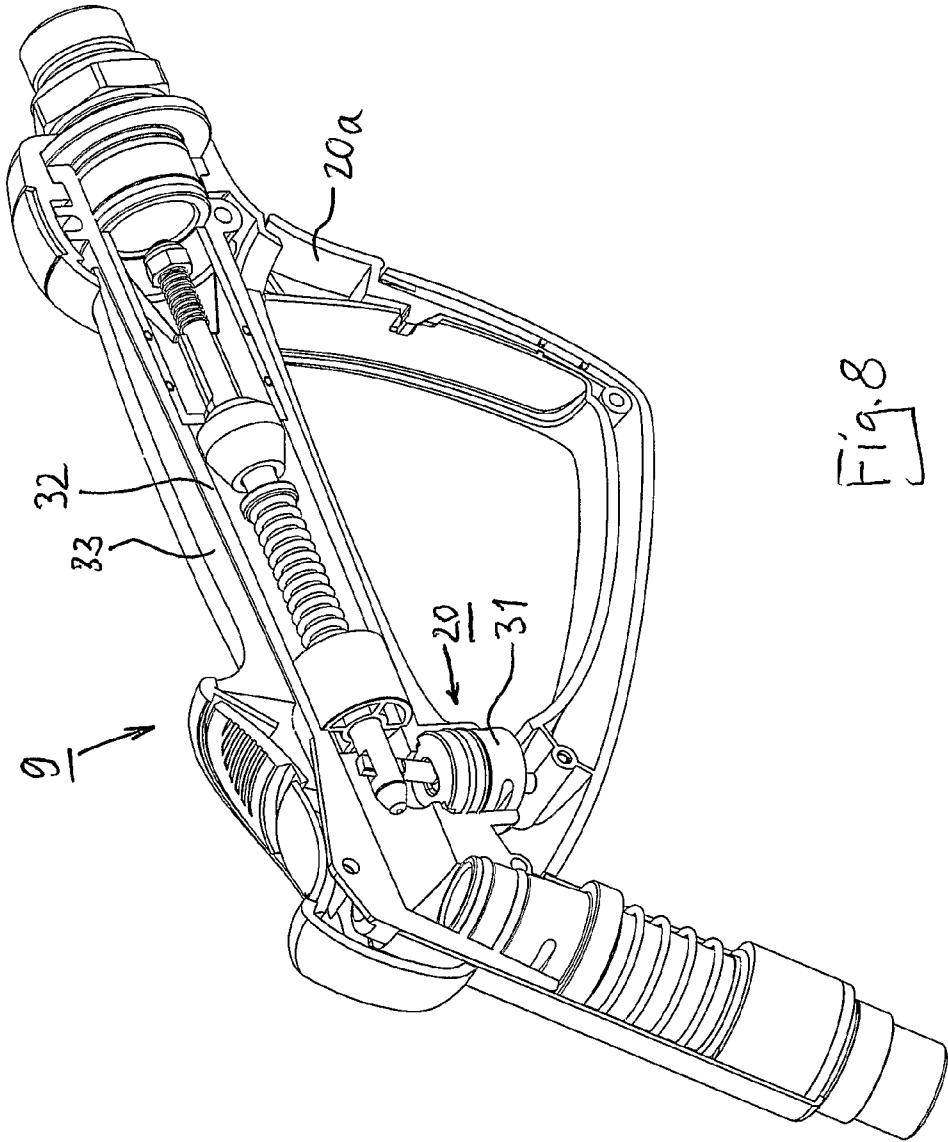

Fig. 8

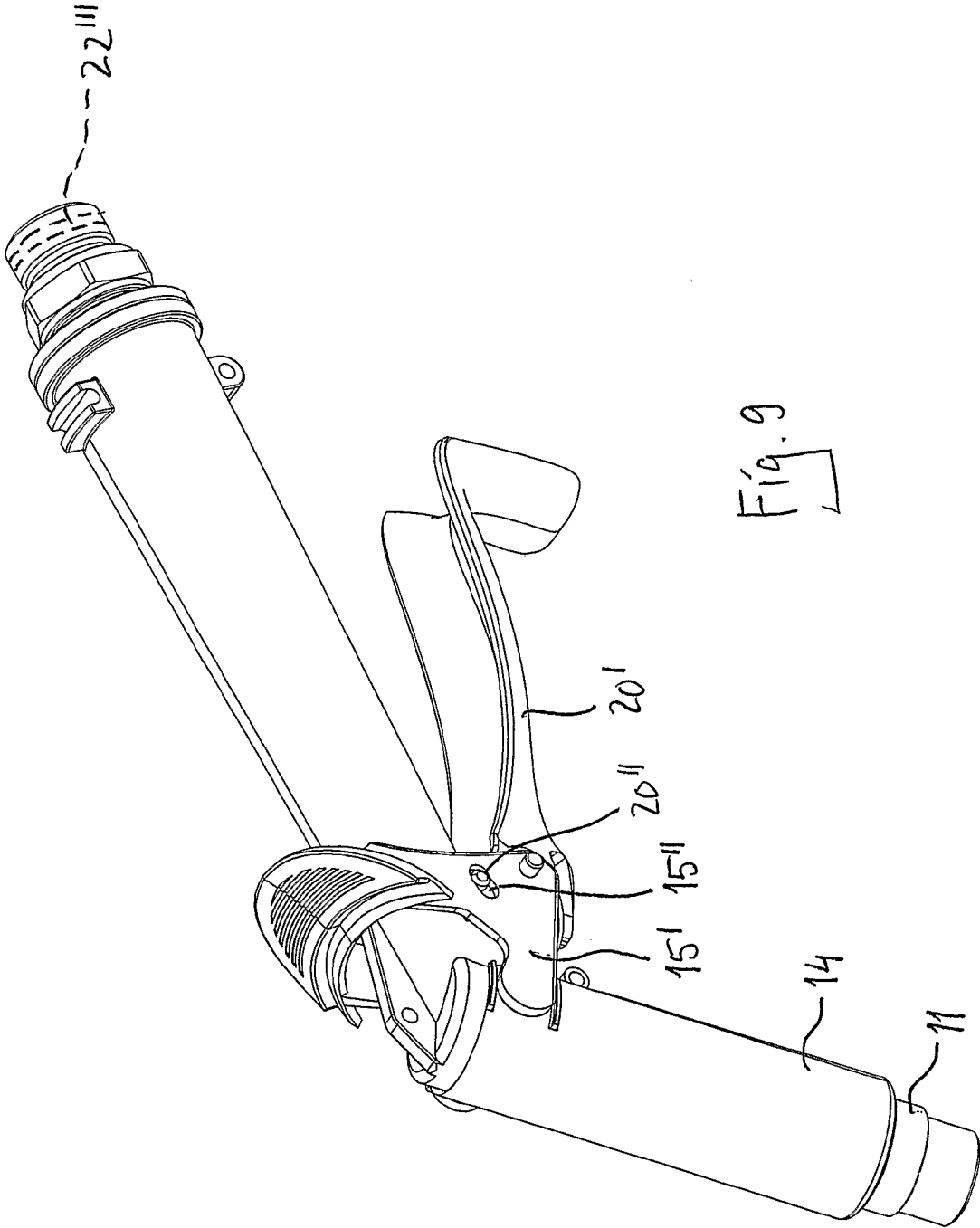

Fig. 9

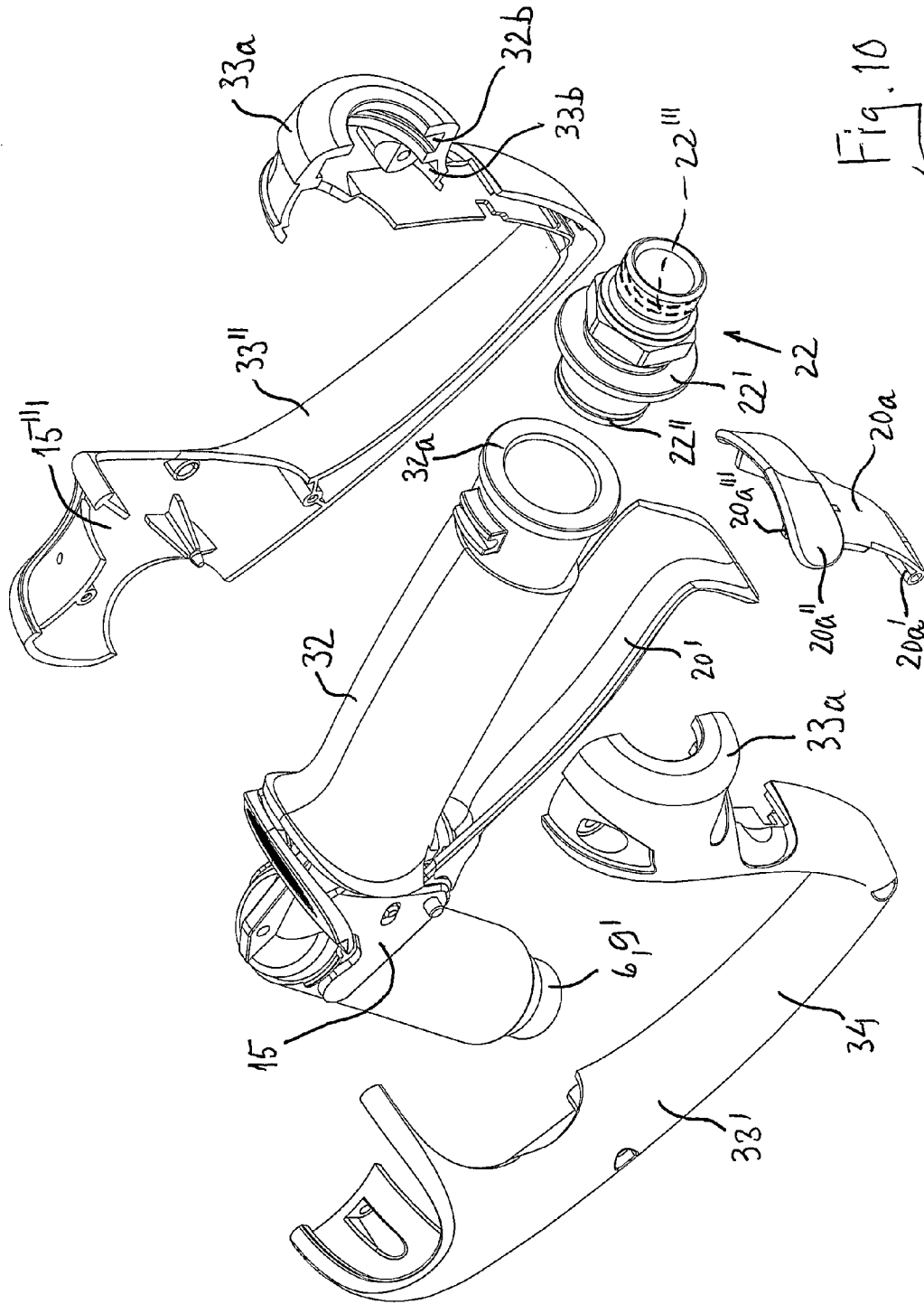

Fig. 10

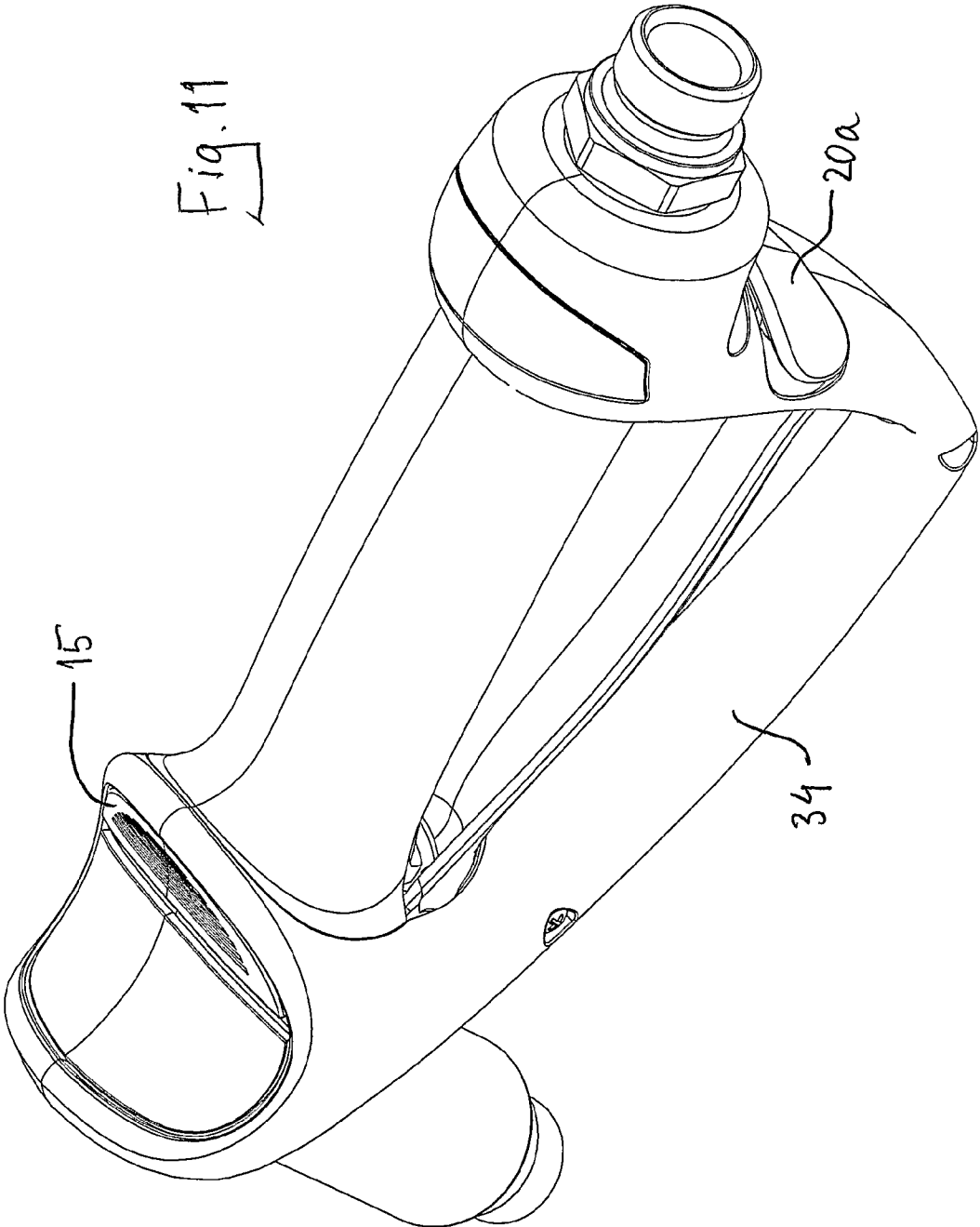
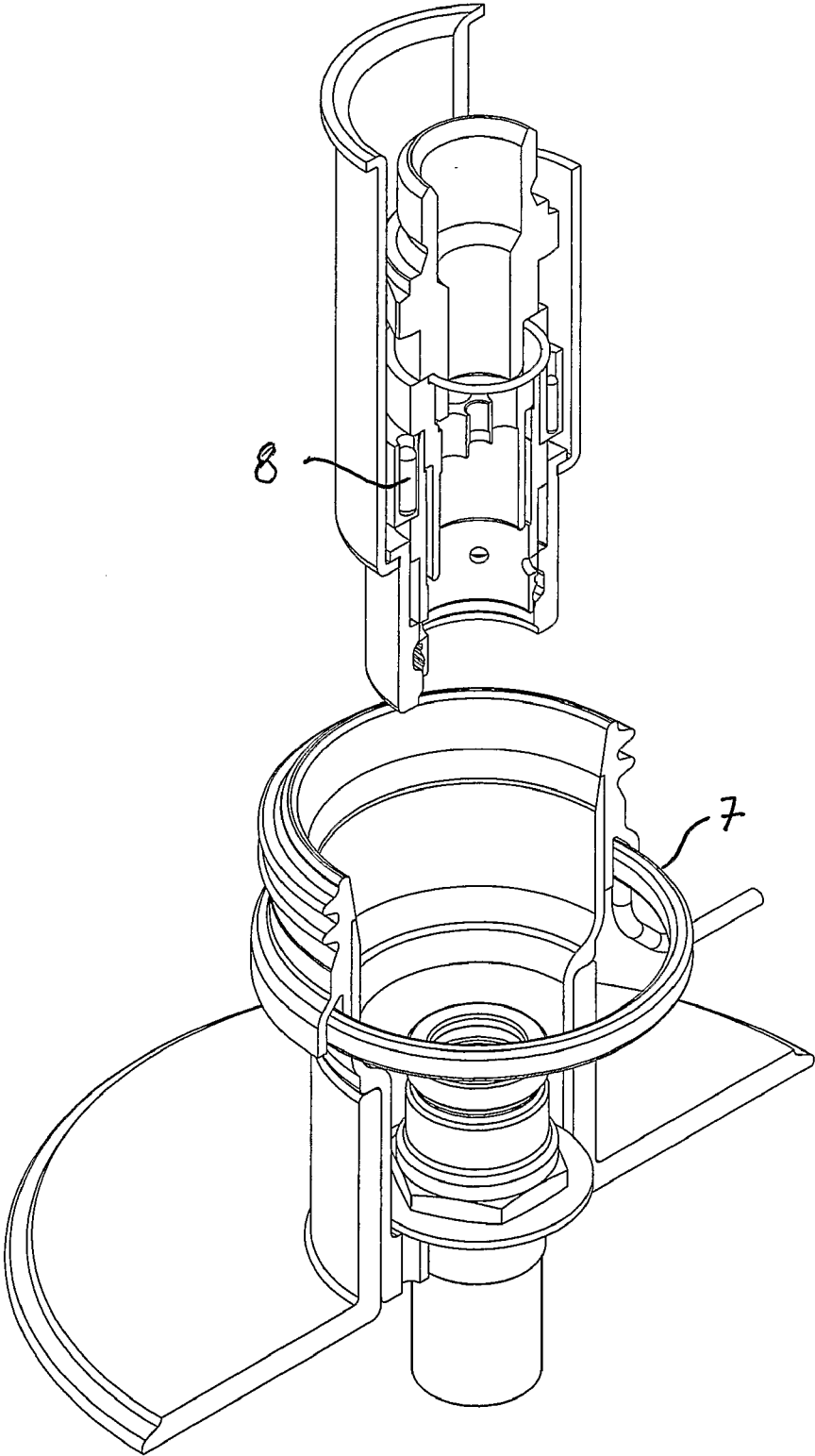

Fig. 12



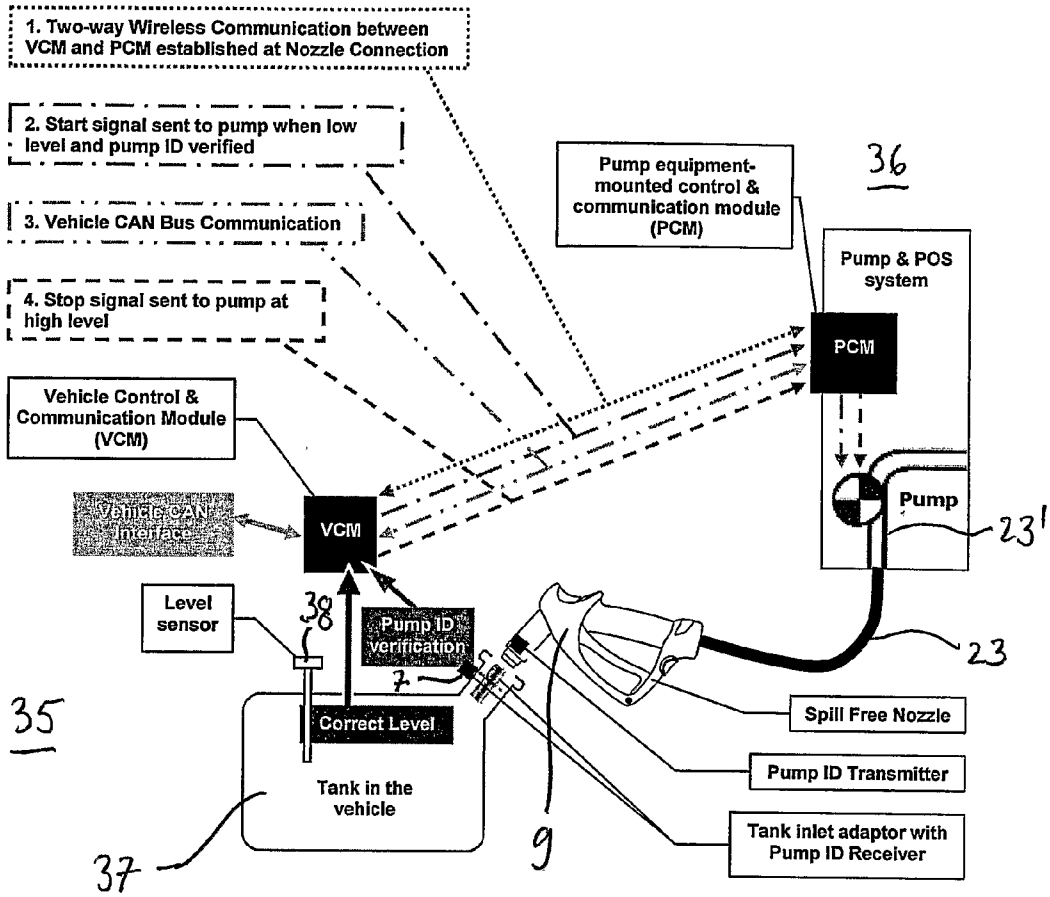
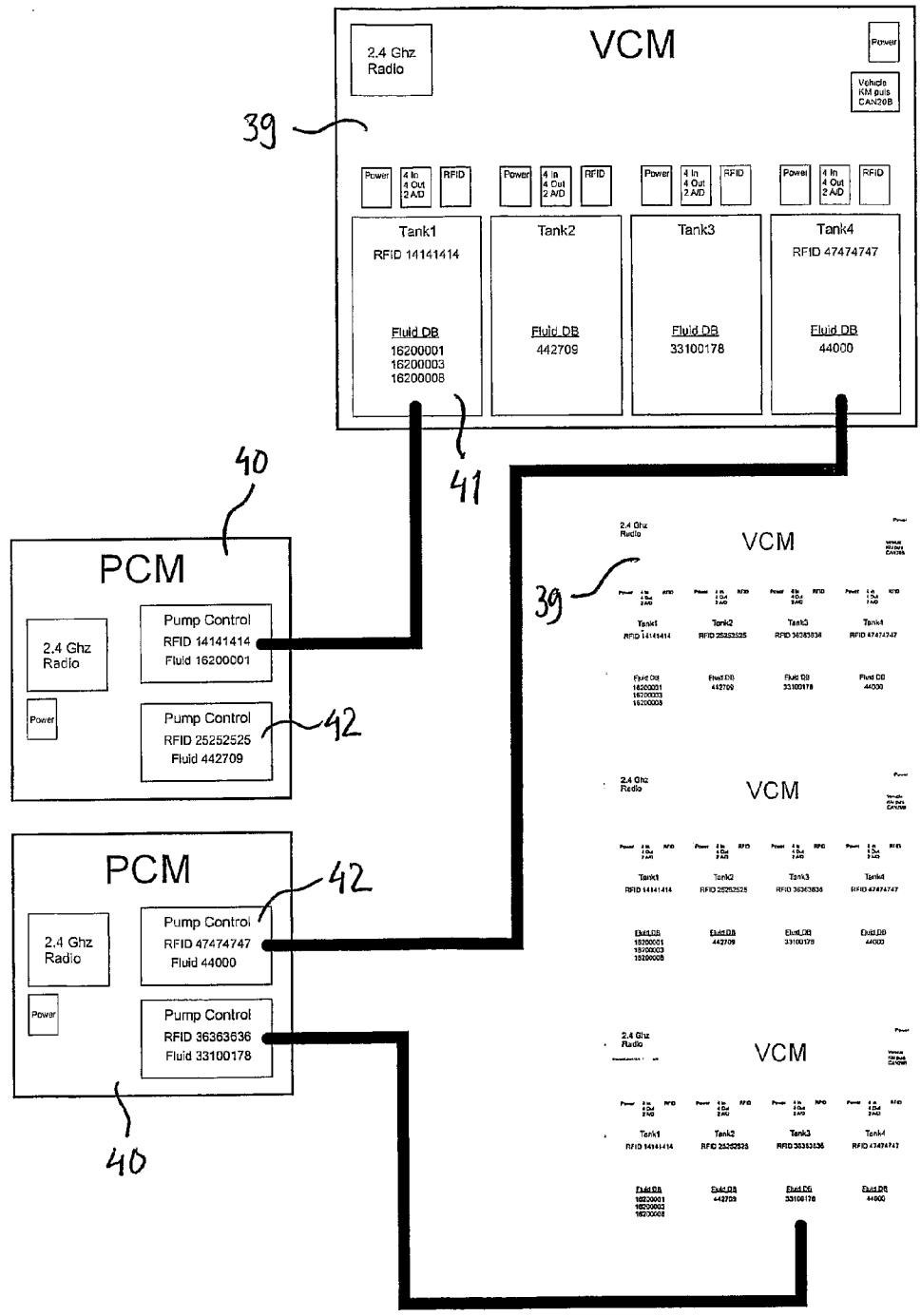

Fig. 13

Fig. 14



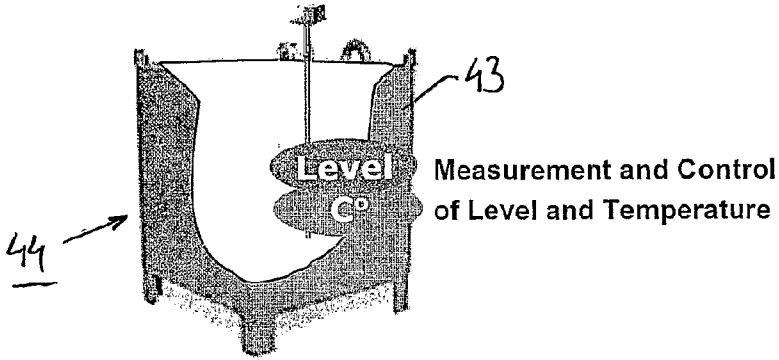

Fig. 15a

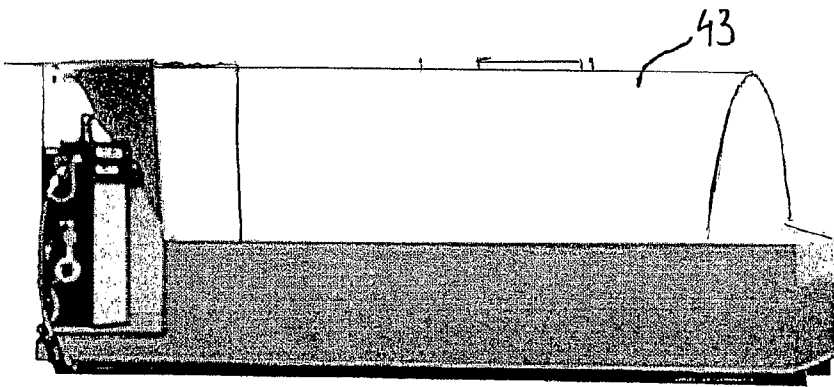

Fig. 15b

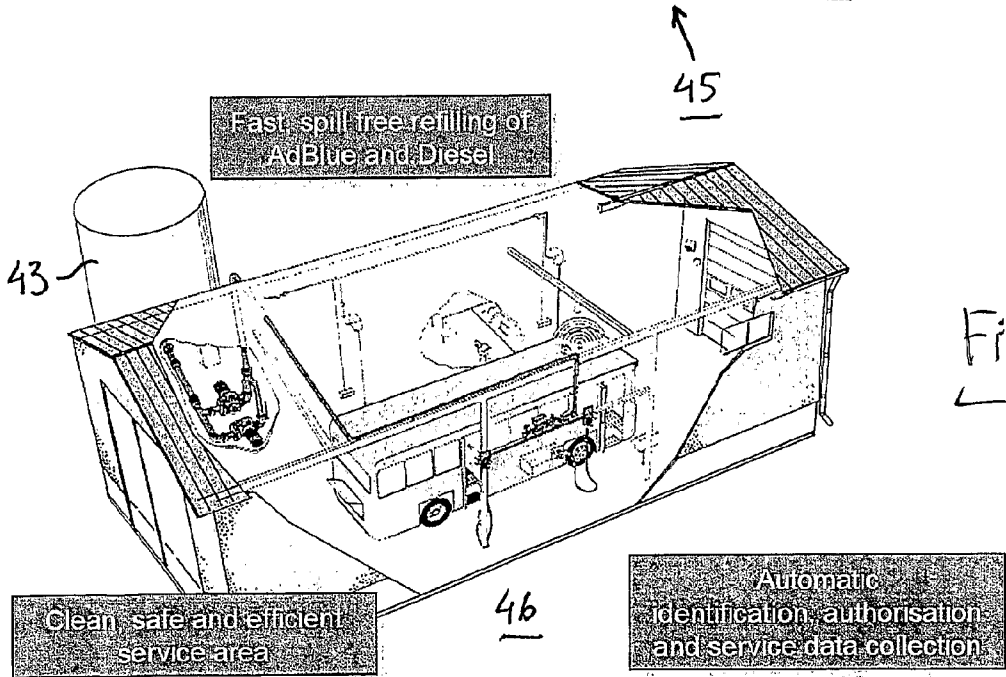

Fig. 15c

**USE OF A METHOD AND A SYSTEM FOR
SPILL-FREE REFILLING OF LIQUIDS, GUN FOR
SPILL-FREE REFILLING OF LIQUIDS,
CONNECTION FOR A TANK, METHOD AND
SYSTEM FOR CONTROL AND COMMUNICATION
IN A SPILL-FREE LIQUID REFILLING SYSTEM,
METHOD AND SYSTEM FOR MEDIA PROVISION
IN A SPILL-FREE REFILLING SYSTEM,
SPILL-FREE AND LIQUID-TIGHT REFILL**

BACKGROUND OF THE INVENTION

[0001] 1. Technical field

[0002] The present invention relates to the use of a method and a system for spill-free refilling of liquids for e.g. vehicles, according to the introductory part of claim 1.

[0003] The invention further relates to a gun for spill-free refilling of liquids.

[0004] The invention also relates to a connection for a tank.

[0005] The invention further relates to a method and a system for control and communication in a spill-free liquid refilling system.

[0006] The invention also relates to a method and a system for media provision in a spill-free refilling system.

[0007] The invention further relates to a spill-free and liquid-tight refilling connection.

[0008] The invention also relates to computer programme products.

PRIOR ART

[0009] Previously known are methods and systems for spill-free refuelling of e.g. vehicles, such known techniques involving a spill-free coupling comprising a, normally male, fuel container part and a, normally female, refuelling nozzle part of a refuelling gun. According to such techniques, refuelling is not possible until a spill-free connection is established between said parts.

SUMMARY OF THE INVENTION

[0010] According to recent development for reducing emissions from diesel engines, a liquid solution for selective catalytic reduction, SCR, an exhaust after-treatment technology, is used, a specific such compound being called AdBlue® and comprising a 32.5% by weight solution of urea in water, the compound being specified in the DIN standard DIN V 70 070, the urea solution, when applicable, being kept in a separate vehicle mounted tank or container of the diesel engine vehicle.

[0011] According to a first aspect of the present invention, use is made of a method and a system for spill-free refilling of a liquid solution for SCR, into tanks as a solution to the problem of unwanted distribution of such compounds which, although classified as non-toxic, are corrosive etc. in certain environments and have special properties with regard to exposure to air and cold, and the problem of supervising the use and consumption of such compounds.

[0012] According to a second aspect of the present invention, a gun for spill-free refilling is provided as a solution to the problem of establishing a safe and detectable spill-free

connection between a liquid container and a refilling nozzle, and the problem of handling solutions for SCR, when applicable.

[0013] According to a third aspect of the present invention, a liquid container connection is provided as a solution to the problem of providing a standard connection for specific liquids.

[0014] According to a fourth aspect of the present invention, a method and a system for control and communication in a spill-free refilling system is provided as a solution to the problem of supervising the media provision as far as kind of media and, when applicable, refilling order is concerned, the problem of stopping the refilling at a predetermined liquid level in the liquid container and the problem of collecting static and dynamic specific information and refilling information to e.g. a central management system employing a spill-free refilling system.

[0015] According to a fifth aspect of the present invention, a method and an arrangement for media provision in a spill-free refilling system is provided as a solution to the problem of keeping record of the consumption etc. of a stored liquid and the problem of freezing of the liquid.

[0016] According to a sixth aspect of the present invention, a spill-free and liquid-tight refilling connection is provided as a solution to the problem of obtaining a reliable coupling and release mechanism and of signalling coupling and release of the connection.

[0017] According to a seventh aspect of the present invention computer programme products are provided.

[0018] These and other associated problems are solved by means of the inventions specified in the attached independent claims. Preferred embodiments are specified in the respective dependent claims.

BRIEF DESCRIPTION OF THE DRAWINGS

[0019] A better understanding of the present invention will be had upon the reference to the following detailed description when read in conjunction with the accompanying drawings, wherein like reference characters refer to like parts throughout the several views, and in which:

[0020] FIG. 1 schematically shows an axial section of a first embodiment of a tank inlet and a first embodiment of an adapter to be fitted into the inlet and carrying a male part of a spill-free coupling,

[0021] FIGS. 2a and b show, partly in an axial section, both a male coupling part, fitted into a tank inlet according to FIG. 1 by means of an adapter according to FIG. 1, and a female coupling part, carried by a refilling gun, in an unconnected state (a) and the two parts in a connected state (b),

[0022] FIG. 3a shows, partly in an axial section, in more detail the male part substantially according to FIG. 2, FIG. 3b shows, partly in an axial section, in more detail the female part substantially according to FIG. 2, and FIG. 3c shows, also in more detail, the two coupling parts of FIGS. 3a and 3b in a connected state, FIG. 3d showing the female part of FIG. 3a without axial section,

[0023] FIG. 4 shows a side view of a coupling collar according to e.g. FIGS. 3a and c,

[0024] FIG. 5a schematically shows an axial section of a second embodiment of a tank inlet and a second embodiment of an adapter fitted into the inlet and carrying a male part of a spill-free coupling;

[0025] FIG. 5b schematically shows an assembly according to FIG. 5a in three perspective views, one partly sectioned, one complete and one with a cap for cover,

[0026] FIG. 6 shows an exploded perspective view of a first embodiment of a refilling gun according to the invention,

[0027] FIG. 7 shows the gun of FIG. 6 in a partly exploded perspective view, in which one half of the cover is removed, together with one half of the cover,

[0028] FIG. 8 shows the gun of FIG. 7 in a non-exploded state,

[0029] FIG. 9 shows a full perspective view of the gun according to FIG. 6,

[0030] FIG. 10 shows the gun according to FIG. 9 together with i.a. two halves of cover in a perspective view,

[0031] FIG. 11 shows the arrangement according to FIG. 10 put together as an assembly,

[0032] FIG. 12 shows, in a perspective view, substantially one half of the spill-free coupling, substantially according to FIG. 2, specifically showing an identification etc. transponder arranged in the female coupling part and an antenna arranged in the adapter for fitting the male coupling part into the vehicle tank inlet,

[0033] FIG. 13 schematically shows communication in a control and communication system in a spill-free liquid refilling system,

[0034] FIG. 14 schematically shows communication between multiple channel program cards of vehicle and pump control and communication modules and

[0035] FIG. 15a-c schematically show a comparatively small stand-alone tank unit (a), a mobile refilling unit (b) and an integrated system (c).

DETAILED DESCRIPTION OF PREFERRED EMBODIMENTS

[0036] The arrangement, the connection, according to FIG. 1 for spill-free refilling comprises a tank inlet 1 in the form of a preferably cylindrical pipe part 2 protruding from a tank-wall piece 3. An adapter 4 is arranged to be fitted axially into the tank inlet and to carry a tank coupling part 5 of the spill-free connection, the tank coupling part being intended to be connected to a refilling gun coupling part 6, FIG. 2 e.g., for spill-free and liquid-tight refilling as described below and shown in e.g. FIGS. 2 and 3.

[0037] In order to standardize the refilling arrangement for different liquids and, e.g., vehicles and for providing a mechanical selectivity system, the tank inlet has standard dimensions so that a standard adapter/coupling part designed for a specific liquid may be fitted into it. According to a preferred embodiment, the arrangement is intended for refilling for SCR by means of AdBlue®.

[0038] Further, as shown in e.g. FIG. 2a, according to a preferred embodiment the adapter carries an antenna 7 arranged to communicate with a transponder 8 carried by the refilling gun 9.

[0039] The adapter part turned from the tank is preferably adapted, preferably by means of threads 4" or the corresponding, to receive a cap 10 covering the adapter and, thus, the tank coupling part.

[0040] Further, the connection is preferably sealed, as indicated in FIG. 1, so that refilling is possible only through the tank coupling part by the refilling gun coupling part.

[0041] The spill-free and liquid-tight refilling connection is shown in more detail in FIGS. 2-4 and comprises a first coupling part 6 carried by a refilling gun 9 and a second coupling part 5 carried by a tank inlet adapter, the coupling parts being arranged to co-act in order to open a refilling connection in at least two steps, the first coupling part 6 opening the second coupling part 5, which thereafter opens the first coupling part during establishment of a refilling connection between the coupling parts, and to close the refilling connection in at least two steps, the first coupling part first being closed and thereafter closes the second coupling part when the connection is released, the procedure taking place between the two states shown in FIGS. 2 and 3.

[0042] The first coupling part 6 comprises a coupling collar 11, FIG. 4, movable between a coupling position, shown in FIGS. 2b and 3b, and a release position, shown in FIGS. 2a and 3a, and comprising flange means 12 arranged to co-act with flange means 13 of a release sleeve 14 of the gun arranged to be moved axially from a coupling position to a release position for moving the coupling collar to the release position of the coupling collar.

[0043] According to a preferred embodiment, the release sleeve 14 is movable by means of a link element 15, FIG. 6 e.g. of the gun, the link element being intended to be operated by a refilling operator at release. Further, the link element is intended to serve also as a signalling means, indicating when coupling connection is established and released, respectively, the link element being turnable between a release position and a raised connection position and vice versa.

[0044] Further, according to a preferred embodiment shown in the drawings and specifically in FIG. 9, the link element 15 is arranged to provide a releasable locking function to prevent movement of the release sleeve to the release position if a trigger handle 20', described later, is out of a non-refilling position. According to the embodiment shown, the link element is provided with two link arms 15', one on each side of the release sleeve 14 for movement of the sleeve, and pivotably fastened preferably together with the trigger handle 20', the link element being arranged with at least one but preferably two elongated holes 15", one on each side, in which holes two locking pins 20" of the trigger handle are fitted so that the link element is pivotable to move the release sleeve to a release position when the trigger handle is in a non-refilling position as shown in FIG. 9 and so that the link element is locked by means of the holes and pins and not pivotable to move the release sleeve to the release position when the trigger handle is in a refilling position as is obvious from FIG. 9.

[0045] Furthermore, according to a preferred embodiment, the second coupling part is arranged in the tank inlet adapter so that the tank is ventilated both for over-pressure in the tank due to refilling and for under-pressure in the tank due to consumption of the tank content. Over-pressure is ventilated e.g. by means of a, e.g. ring-shaped, membrane 16, e.g. a rubber membrane associated with the second coupling part at the tank inlet adapter, as shown schematically in FIGS. 2a

and 2*b*. Under-pressure is ventilated e.g. by means of the second coupling part, which is opened against a spring force, the second coupling part being arranged with a spring 17 sufficiently soft for opening for ventilating the tank at under-pressure in the tank. Other solutions are also imaginable. Thus, according to yet another embodiment, threads 4" for mounting the cap 10 to the tank inlet adapter are provided with at least one channel, not shown, for ventilating the tank at under-pressure.

[0046] According to the second embodiment of a tank inlet 1' and the corresponding adapter 4', FIGS. 5*a* and *b*, the adapter as a unit comprises both a tank coupling part 5 of the spill-free connection and a principally open inlet 1" for refilling arranged in a housing 1" of the adapter 4', the housing thus comprising two openings arranged comparatively close together and arranged to be covered by a cap 10' in a non-refilling mode. According to preferred embodiments the non-spillfree open inlet is provided with a separate removable cap 10".

[0047] Further, according to a preferred embodiment electronics, antenna etc, not shown, for the operation of the refilling procedure etc are arranged in the housing.

[0048] For spill-free and liquid-tight refilling of liquids, a refilling gun 9 is provided, said gun, FIGS. 6-11, comprising a dispensing nozzle 9', i.e. said first coupling part 6, a handle part 19, a trigger 20 intended to be operated by a refilling operator, a valve arrangement 21 to be activated by the trigger and a liquid input connection 22 for connecting the gun to a liquid provision pipe 23 connected to a pump 23', FIG. 13. According to a preferred embodiment, FIG. 7 e.g., the gun is provided with a trigger device for transferring a trigger handle 20' movement performed by an operator of the gun to valve means 21', the trigger device providing a sealed, liquid-tight mechanical movement transfer between the trigger handle and the valve means and comprising a lever rod 24 carrying a centrally located substantially spherical sealing and journalling body 25 arranged between an upper 26 and a lower 27 sealing and lever rod guiding seat, the trigger handle being arranged for applying a force to the lever rod end 28 turned to the trigger handle, the lower end, said force being substantially perpendicular to the axial direction of the lever rod for turning the lever rod, and thus the body 25, in the journalling arrangement in a plane substantially parallel to the axial direction of the lever rod, the lever rod end 29 turned from the trigger handle, the upper end being arranged for applying an axial force to a valve rod 30 to open the gun valve 30' when said lever rod is turned, the valve rod 30 being pulled against a spring force by said force, the arrangement being schematically shown in FIGS. 6-8. The seat 26, 27 and body 25 arrangement for the lever rod is supported and held in a sleeve-like housing 31 of the gun handle. Thus, no liquid is intended to pass the body 25 to the trigger handle end of the lever rod.

[0049] According to a preferred embodiment the gun handle comprises an inner housing 32 or cover, in which the gun valve arrangement etc. is arranged and which carries the first coupling part, the coupling sleeve, the link element etc., and an outer housing 33 or cover, FIGS. 10 and 11, also providing a safety frame 34 for the trigger handle.

[0050] FIG. 13 shows a preferred embodiment of a control and communication system for a spill-free refilling system according to the invention, the system comprising, as two basic parts, a vehicle part 35 and a pump part 36, the vehicle part being located mainly in the left portion of FIG. 13 and the pump part mainly in the right part of FIG. 13.

[0051] A basic element of the system is a wireless two-way communication system, indicated by communication arrows, for communication between a, e.g. vehicle-mounted, control and communication module VCM and a pump, control and communication module PCM for controlling the refilling of at least one, e.g. vehicle-mounted, tank 37.

[0052] Further elements of the system are

[0053] spill-free nozzle with the first coupling part and transmitter for pump identification;

[0054] tank inlet adapter with pump identification receiver, antenna, connected to the VCM;

[0055] level sensor or meter 38 connected to the VCM, for detecting a predetermined upper liquid level indicating an upper limit level in the tank and preferably for detecting levels below said predetermined upper limit liquid level for indicating the need for refilling;

[0056] pump 23' and pump control system POS for detecting and registering the amount refilled and for controlling the refilling procedure;

[0057] various vehicle-mounted sensors and transmitters, not shown, for transfer of vehicle-specific data to the VCM, e.g. kilometer pulse sensor and pressure and temperature sensors for gaseous fuels.

[0058] In FIG. 12 the information transfer arrangement provided in the spill-free coupling is specifically illustrated, the arrangement comprising a transmitter, a preferably passive identity, e.g. RF, carrier, applied to the gun nozzle for wireless transfer of pump identity and, preferably, gun nozzle identity to the VCM by means of a, e.g. RF, antenna connected to the VCM, the antenna being positioned adjacent to the corresponding tank inlet.

[0059] Parameter initiation and other configuration of the VCM and the PCM are in both cases arranged to be performed via direct connection to a serial port, wireless communication or a superior system, e.g. with Internet access, arranged for communication with the VCM/PCM, respectively, or combinations thereof (not shown).

[0060] According to preferred embodiments, the control and supervision performed by means of the system relates to at least one of the following features:

[0061] refilling a certain medium into the correct tank;

[0062] starting refilling at a level below a predetermined level;

[0063] stopping the refilling at said predetermined level;

[0064] transferring static and dynamic vehicle specific information carried by the vehicle and refilling information to a superior compiling and/or storing management system.

[0065] Further, according to preferred embodiments, a refilling procedure comprises the following steps, the system being provided with the corresponding arrangements:

[0066] activating the PCM wireless communication e.g. by removing the gun from a gunstoring position at the pump;

[0067] establishing a spill-free and liquid-tight connection between the gun nozzle and the tank inlet by means of the first and the second coupling part;

- [0068] registering, checking and storing the pump identity of the gun nozzle and verifying by the VCM the correctness of the combination of tank, gun and pump, i.e. the liquid provided; performing the communication between the PCM and the correct VCM, using the pump identity information and transferring further vehicle information, when applicable, to the PCM for storing and, preferably, checking against authorisation information in a superior system;
- [0069] checking the need for refilling by means of an upper limit level sensor or level meter communicating with the VCM before giving access to pump start and refilling;
- [0070] automatically stopping the refilling when a predetermined upper limit level detected by said sensor/meter is communicated to the PCM via the VCM, and, preferably,
- [0071] registering the refilling information e.g. in a superior compiling and/or storing management system.
- [0072] Further, preferred is also that the refilling is automatically stopped when the dispensing nozzle connection to the tank inlet is disconnected and also that the refilling is automatically stopped when the wireless communication between the VCM and the PCM is broken.
- [0073] FIG. 14 shows, schematically, communication between program cards 39 of a vehicle-based VCM and program cards 40 of pump-based PCM:s, each VCM card comprising four channels 41 corresponding to four tanks of the vehicle and each PCM comprising two channels 42 corresponding to two pumps by means of pump 23' ID transferred via the gun/tank inlet connection to the VCM, a check being intended to be performed between the VCM card channel and the PCM card channel in order to check that a correct liquid is refilled to the tank of this channel. Of course, the card may be designed to comprise only one channel or more channels, e.g. two or four as in FIG. 14.
- [0074] The different storing arrangements shown in FIG. 15 are specifically arranged for handling liquid solutions for selective catalytic reduction, especially AdBlue®. For this, the respective containers 43, tanks, are provided by a temperature sensor for supervision of the solution temperature, AdBlue® specifically freezing at about -11° C. Further, each container is provided with means (not shown) for measuring the container content in order to keep a strict record of the consumption, incoming amount and outgoing amount. This shall be the case irrespective of if the container is part of a comparatively small stand-alone unit 44, FIG. 15a, a mobile unit 45 with pump arrangement etc., FIG. 15b, or integrated in a service and refilling depot 46, FIG. 15c.
- [0075] The methods as well as the function of the systems and other arrangements according to the invention should to a substantial part have been made clear from the description given above.
- [0076] Thus, the basic method and system function is the ones described in association with FIG. 13, the main idea being to fully control and supervise the spill-free refilling process, keeping record of the liquid consumption as well as liquid input and output of the system together with additional information for statistics etc. This goes especially for AdBlue® or the corresponding liquid solutions for SCR since it is very important that the correct product, e.g. AdBlue®, is used and that it is used in amounts specified for a certain diesel engine.
- [0077] Furthermore, also the components of the described systems are adapted for liquids like AdBlue® or other corresponding SCR liquids, spill-free and liquid-tight performance being an important feature.
- [0078] Crystal formation at air exposure has been considered for certain components of the systems and arrangements, especially for the spill-free coupling parts. Thus, in the first coupling part, e.g. FIG. 3a, an internal space 42 available for axial movement of an internal ring-shaped element 43 against a spring force for opening the coupling part is arranged so that it is always exposed to the liquid, a sealing 44 between the outer peripheral surface 45 of said element and the inner surface 46 of an element-guiding sleeve part 47 of the coupling preventing air from entering into said space, whereby crystal formation is prevented.
- [0079] Part of the present invention are also computer programme product comprising a programme code for performing method steps of, primarily, anyone of the attached claims 21-34, 48 and 49. The programme code may e.g. be stored on a computer readable media or directly stored in an internal memory of a computer. According to preferred embodiments the necessary computer capacity and the corresponding memory capacity are part of both the VCM and the PCM further computer program products are specified in claims 53-59 as part of the present invention.
- [0080] Above, the invention has been described in association with preferred embodiments.
- [0081] Of course, further embodiments and minor changes and additions may be imagined without leaving the basic inventive idea.
- [0082] Thus, according to preferred embodiments the other housing 33, FIGS. 10 and 11, is made up of two halves 33', 33'' corresponding to each other and being arranged to be put and held together as a cover for the inner housing 32 comprising the valve arrangement. The outer housing provides an opening 15'' for the link element 15, a part of said element being arranged to protrude out of the opening in the revised connection position described above.
- [0083] The outer housing end part 33a being intended to be turned to a pipe, not shown, for liquid provision to the gun, also provides a seat 33b for holding the inner housing end part and valve connection 32a, and a seat 32b for the liquid input connection 22, the connection 22 comprising flange means 22' being rotatably clamped in said seat offering a swivel configuration for the connection 22 in the outer housing end part 33b, the connection being intended to be e.g. by means of O-rings 22'', sealingly introduced into the inner housing end part 32a.
- [0084] Further, according to a preferred embodiment a locking arm 20a, FIGS. 7 and 10 e.g., is provided for releasably holding the trigger handle 20', in a refilling position, i.e. upwards from the non-refilling position shown in e.g. FIG. 10, the locking arm being arranged in the rear end of the outer cover and having a fastening piece 20a' in its end turned from the trigger handle, a preferably platelike push piece 20a'' in its other end, this end being free, and a support piece 20a''' turned to the trigger handle between said ends, the locking arm being resilient and intended to be pushed against a spring force from a non-locking position shown in e.g. FIG. 11 to a locking position in which the free end 20'' of the trigger handle in a refilling position rests upon the support piece preferably by means of a groove, not shown, in the trigger handle free end, the locking arm by its resilience being intended to return to the non-locking position.

tion when the trigger handle is lifted and thus releases the support piece 20a''' and thus permitting the trigger handle to return to the non-refilling position. The locking arm is preferably made of a polymeric material in one piece.

[0085] Also it should have been made clear that the invention, although especially designed for a solution for SCR, such as AdBlue®, to a considerable extent is applicable for other liquids, such as diesel fuel, other vehicle fuels etc., and for other applications than vehicles. Also issued have been made clear that, although the invention is especially designed for vehicles and refilling related to vehicles, the application of the invention for vehicles should be considered as an example, the invention being applicable for other objects than vehicles, e.g. stationary objects of various kinds. Thus, the tank subject to refilling does not have to be a vehicle tank but e.g. a stationary or mobile storage tank. Furthermore, the pump does not have to be stationary but may e.g. be carried by a vehicle. Further, a locking arm 20a are described above may be applied in other guns for refilling and not only in the ones described here.

[0086] Thus, the invention shall not be considered limited to the embodiments shown but may be varied within the scope of the attached claims.

1. Method for spill-free refilling for a liquid solution for selective catalytic reduction, SCR, an exhaust after-treatment technology for diesel engines, said method comprising the steps of establishing a liquid-tight connection between a coupling part (5) of a tank (37), and a coupling part (6) of a dispensing nozzle (9') of a gun (9) for spill-free refilling.

2. Method according to claim 1, characterized in that said solution constitutes a liquid solution of urea in water, said solution preferably comprising 32.5% by weight urea in water and preferably being of the kind provided under the name.

3. Method according to claim 1, characterized in that the method further comprises the steps of

providing a mechanical selectivity in the spill-free connection (5,6), and

providing an refilling authorisation system (35,36).

4. A system for spill-free refilling for a liquid solution for selective catalytic reduction, SCR, an exhaust after treatment technology for diesel engines, the system comprising means (5,6) for establishing a liquid-tight connection between a coupling part (5) of a tank (37) and a coupling part (6) of a dispensing nozzle (9') of a gun (9) for spill-free refilling.

5. The system according to claim 4, characterized in that said solution constitutes a liquid solution of urea in water, said solution preferably comprising 32.5% by weight urea in water and preferably being of the kind provided under the name of AdBlue®.

6. The system according to claim 4, characterized in that the system comprises a mechanical selectivity system in the spill-free connection (5,6) and an electric/electronic refilling authorisation system (35,36).

7. Gun for spill-free refilling of liquids comprising a dispensing nozzle, a handle part, a trigger with a trigger handle, a valve arrangement to be activated by the trigger, and a liquid input connection for connecting the gun to a liquid provision pipe, the nozzle comprising a nozzle coupling part arranged to be releasably connected to a tank coupling part to form a liquid-tight connection for spill-free transfer of liquid from the gun to the tank, characterized in

a release sleeve (14) arranged substantially outside of the nozzle (9') coupling part (6), the sleeve being axially movable by means of a link element (15) from a coupling position to a release position and comprising flange means (13) arranged to co-act with flange means (12) of a coupling collar (11) of said nozzle coupling part to move said coupling collar axially into a release position.

8. Gun according to claim 7, characterized in a trigger device (20) for transferring a trigger handle (20') movement performed by an operator of the gun to valve means the trigger device, providing a sealed, liquid-tight mechanical movement transfer between the trigger handle (20') and the valve means, comprising a lever rod (24) carrying a centrally located substantially spherical sealing and journaling body (25) arranged between an upper (26) and a lower (27) sealing and lever rod guiding seat, the trigger handle being arranged for applying a force to the lower end (28) of the lever rod, said force being substantially perpendicular to the axial direction of the lever rod, for turning the lever rod in the journaling arrangement in a plane substantially parallel to the axial direction of the lever rod, the upper end part (29) of the lever rod being arranged for applying an axial force to a valve rod to open the gun valve (30') when said lever rod is turned.

9. Gun according to claim 7, characterized in that the link element (15) is arranged to provide a releasable locking function to prevent movement of the release sleeve to the release position if the trigger handle (20') is out of a non-refilling position.

10. Gun according to claim 9, characterized in that the link element is provided with two link arms (15'), one on each side of the release sleeve (14) and pivotally fastened preferably together with the trigger handle, the link element being provided with at least one but preferably two elongated holes (15''), one on each side, in which holes two locking pins (20'') of the trigger handle are fitted, so that the link element is pivotable to move the release sleeve to the release position when the trigger handle is in a non-refilling position and so that the link element is locked by means of the holes and pins and not pivotable to move the release sleeve to the re-lease position when the trigger handle is out of the non-refilling position, e.g. in a refilling position.

11. Gun according to claim 7, characterized in that a locking arm (20a) is provided for releasably holding the trigger handle (20') in a refilling position.

12. Gun according to claim 11, characterized in that the locking arm at one end, this end being turned from the trigger handle, being provided with a fastening piece (20a') and in the other end, this end being free, being provided with a push piece, and between the ends being provided with a support piece (20a''') turned to the trigger handle, the locking arm being resilient and arranged to be pushed against a spring force by an operator of the gun from a non-holding position to a holding position, in which a free end (20''') of the trigger handle rests upon the support piece, the locking arm being arranged by its resilience to return to the non-locking position when the trigger handle is lifted to release the support piece and thus permitting the trigger handle to return to the non-refilling position.

13. Gun according to claim 11, characterized in that the resilient locking arm is made of a polymeric material in one piece.

14. Connection for a tank for a liquid, the connection being for spill-free refilling and comprises a tank coupling

part arranged to be connected to a refilling gun coupling part for spill-free refilling, characterized by inlet (1,1') in the form of a preferably cylindrical pipe part (2) protruding from a tank wall piece (3), and an adapter (4,4') to be fitted axially into the tank inlet and carrying the tank coupling part (5).

15. Connection according to claim 14, characterized in that the adapter (4) carries i.a. electronic means for communication, control of the refilling process etc.

16. Connection according to claim 14, characterized in that the adapter (4'), apart from a spill-free refilling tank coupling part (5), comprises a non-spill-free inlet.

17. Connection according to claim 14, characterized in that the tank inlet (1) has standard dimensions so that a standard adapter/coupling part designed for a specific liquid may be fitted into it, a mechanical selectivity system being provided.

18. Connection according to claim 14, characterized in that the adapter (4) carries an antenna (7) arranged to communicate with a transponder (8) carried by the refilling gun.

19. Connection according to claim 14, characterized in that the adapter part turned from the tank is adapted to receive a cap (10,10') covering the adapter and, thus, the tank coupling part.

20. Connection according to claim 14, characterized in that it is sealed, refilling being possible only through the tank coupling part (5) by the refilling gun coupling part (6).

21. Method for control and communication in a spill-free refilling system, characterized in that refilling of at least one tank (37) is controlled by means of wireless two-way communication between a control and communication module (VCM) associated with the tank, and a pump equipment-mounted control and communication module (PCM).

22. Method according to claim 21, characterized in that said tank (37) and said control and communication module (VCM) are vehicle-mounted.

23. Method according to claim 21, characterized by the steps of

establishing a wireless communication connection between the control and communication module (VCM) and the pump equipment-mounted control and communication module (PCM),

transmitting a tank identifying signal identifying the tank from the control and communication module (VCM) to the pump equipment-mounted control and communication module (PCM),

determining in the pump equipment-mounted control and communication module (PCM) to the control and communication module (VCM) whether to start refilling the tank in dependence of said tank identifying signal.

24. Method according to claim 23, wherein said tank identifying signal comprises information of the type of liquid to be held by said tank.

25. Method according to claim 21, further comprising the step of

transmitting a pump identifying signal identifying the pump from the pump equipment-mounted control and communication module (PCM) to the control and communication module (VCM).

26. Method according to claim 21, characterized by the steps of

checking the level of liquid in the tank by means of a level sensor (38) or level meter and starting refilling only if the level is below a predetermined threshold level,

when the level exceeds a predefined threshold level, sending a stop signal from the control and communication module (VCM) to the pump equipment-mounted control and communication module (PCM),

stopping the refilling by the pump equipment-mounted control and communication module (PCM) when said stop signal is received in the pump equipment-mounted control and communication module (PCM).

27. Method according to claim 21, characterized in that said refilling relates to a liquid solution for selective catalytic reduction, SCR, an exhaust after-treatment technology for diesel engines.

28. Method according to claim 21, characterized in that the control relates to at least one of the following supervision features:

refilling a certain medium into the correct tank (37);

starting refilling at a level below a predetermined upper limit level;

stopping the refilling at a predetermined upper limit level;

transferring static and dynamic vehicle specific information carried by a vehicle, when applicable, and refilling information to a superior compiling and storing management system.

29. Method according to claim 21, characterized by the steps of wireless transfer of pump identity of the refilling gun (9) nozzle (9') from an identity carrier transponder (8) applied to the nozzle to the control and communication module (VCM) by means of an antenna (7) connected to said unit, the antenna being positioned adjacent to the corresponding tank inlet (1).

30. Method according to claim 21, characterized in that a refilling procedure comprises the steps of

activating the pump control and wireless communication unit e.g. by removing the gun (9) from a gun storing position at the pump (23'),

establishing a spill-free connection (5,6) between the gun nozzle and the tank inlet,

registering, checking and storing the pump identity of the gun nozzle and verifying by the VCM the correctness of the combination of tank, gun and pump, i.e. liquid provided,

performing the communication between the PCM and the correct VCM, using the pump identity information and transferring, when applicable, further vehicle information to the PCM, for storing.

31. A method according to claim 30 wherein the verifying step comprises

checking against authorisation information in a superior system.

32. A method according to claim 26, further comprising the step of

automatically stopping the refilling when a predetermined level detected by said sensor/meter is communicated to the PCM via the VCM or if the dispensing nozzle is

disconnected of if the wireless communication between the VCM and the PCM is broken.

33. A method according to claim 21, further comprising the step of

registering refilling information, e.g. in a superior compiling storing management system.

34. Method according to claim 21, characterized in that parameter initiation and other configuration of the VCM and the PCM are in both cases performed via direct connection to a serial port, via radio communication or via a superior system, e.g. with Internet access, communicating with the VCM/PCM, respectively, or combinations thereof.

35. System for control and communication in a spill-free refilling system, characterized by a wireless two-way communication system for communication between a control and communication module (VCM) associated with at least one tank that is to be refilled and a pump equipment-mounted communication module (PCM) for controlling refilling of at least one vehicle-mounted tank (37).

36. System according to claim 35, characterized in that said control and communication module (VCM) and said tank (37) are vehicle-mounted.

37. System according to claim 35, characterized in that said refilling relates to a liquid solution for selective catalytic reduction, SCR, an exhaust after treatment technology for diesel engines.

38. System according to claim 35, characterized by an identity carrier, transponder, (8) applied to the refilling gun nozzle (9') for wireless transfer of pump identity of the refilling gun nozzle to the (VCM) by means of an antenna (7) connected to said unit, the antenna being positioned adjacent the corresponding tank inlet (1).

39. System according to any one of the claims claim 35, characterized in that parameter initiation and other configuration of the VCM and the PCM are in both cases arranged to be performed via direct connection to a serial port, radio communication or a superior system, e.g. with Internet access, communicating with the respectively, or combinations thereof.

40. Spill-free and liquid-tight refilling connection comprising a first coupling part carried by a refilling gun for spill-free refilling and a second coupling part carried by a tank inlet, the coupling parts being arranged to co-act in order to open a refilling connection in at least two steps, the first coupling part opening the second coupling part, which thereafter opens the first coupling part, and to close the refilling connection in at least two steps, the first coupling part first being closed and thereafter closes the second coupling part when the connection is released, characterized in that the first coupling part (5) comprises a coupling collar (11) movable between a coupling position and a release position and comprising flange means (12) arranged to co-act with flange means (13) of a release sleeve (14) of the gun arranged to be moved axially from a coupling position to a release position for moving the coupling collar to the release position of the coupling collar.

41. Connection according to claim 40, characterized in that the release sleeve is movable by means of a link element (15) of the gun, the link element being intended to be operated by a refilling operator.

42. Connection according to claim 41, characterized in that the link element is intended to serve also as a signalling means indicating when connection is established and released, respectively.

43. Connection according to claim 40, characterized in that the second coupling part (5) is arranged in a liquid-tight sealed manner in the tank inlet (1), refilling being possible only through the second coupling part as opened by the first coupling part (6).

44. Connection according to claim 40, characterized in that the second coupling part (5) is arranged in the tank inlet (1) so that the tank (37) is ventilated both for over-pressure in the tank due to refilling and for under-pressure in the tank due to consumption of the tank content.

45. Connection according to claim 44, characterized by a membrane (16), e.g. a rubber membrane arrangement associated with the second coupling part (5) at the tank inlet (1) for ventilating the tank at over-pressure in the tank.

46. Connection according to claim 44, characterized in that the second coupling part, which is opened against a spring force, is arranged with a spring (17) sufficiently soft to open for ventilating the tank at under-pressure in the tank.

47. Connection according to claim 44, characterized in that threads (4") or the corresponding for mounting a cap (10) to the tank inlet are provided with at least one channel for ventilating the tank.

48. Method for media provision in a spill-free refilling system comprising a storage tank for a refilling liquid medium, characterized in that said medium is a liquid solution for selective catalytic reduction, SCR, an exhaust after-treatment technology for diesel engines and in that the storage tank (43) content is measured to keep re-cord of input and output of said liquid solution and in that the temperature of the liquid solution preferably is measured.

49. Method according to claim 48, characterized in that the input medium is safety identified in order to secure correct output medium.

50. System for media provision in a spill-free refilling system comprising a storage tank for a refilling liquid medium, characterized in that said medium is a liquid solution for selective catalytic reduction, SCR, an exhaust after-treatment technology for diesel engines and in that means are provided for measuring the storage tank (43) content to keep record of input and output of said liquid solution and in that means preferably are provided for measuring the liquid solution temperature.

51. System according to claim 50, characterized in that it comprises a stand-alone unit (44), a mobile unit (45) or a unit integrated in a service and refilling depot (46).

52. Computer programme product comprising a programme code for performing the method steps of claim 21, when said computer programme is run on a computer.

53. Computer program product for controlling the refilling of at least one liquid tank, said computer program product being arranged, when run in a refilling control unit associated with a tank for spill-free refilling of said tank, perform the following steps:

when a nozzle is received in the tank, receive pump identification information on a wireless connection from a pump control and communications unit (PCM),

transmit a tank signal to the pump control and communications unit (PCM), said signal related to the status of the tank.

54. Computer program product according to claim 53, further arranged to receive level information from a level sensor arranged in said tank and, when the level information indicates that the level exceeds a threshold level, send

a stop signal to the pump control and communications unit (PCM) indicating that the refilling should be stopped.

55. Computer program product according to claim 53, wherein the tank signal comprises an identification of the liquid that should be refilled in the tank.

56. Computer program product for controlling the refilling of at least one liquid tank, said computer program product being arranged, when run in a pump control unit in a system for spill-free refilling, to perform the following steps:

transmit information regarding the pump identity on a wireless connection to a refilling control unit associated with said at least one liquid tank,

receive a tank signal from the refilling control unit, said signal providing tank related information,

starting the refilling in dependence of the tank signal.

57. Computer program product according to claim 56, wherein the step of transmitting information regarding the pump identity is initiated when a nozzle for refilling the tank is removed from the pump.

58. Computer program product according to claim 56, further arranged to receive a stop signal from the refilling control unit and to stop refilling the tank when said stop signal is received.

59. Computer program product according to claim 56, further arranged to receive a tank signal comprising information about the liquid that should be refilled in the tank and start the refilling only if the pump provides said liquid.

* * * * *