

Nov. 21, 1939.

G. R. BROWN

2,180,975

TIME LAG FUSE

Filed Dec. 8, 1938

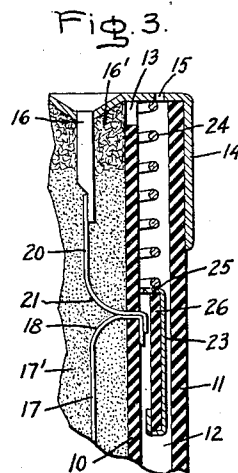
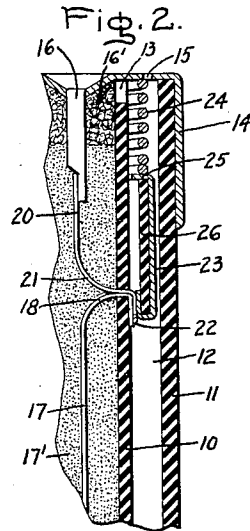
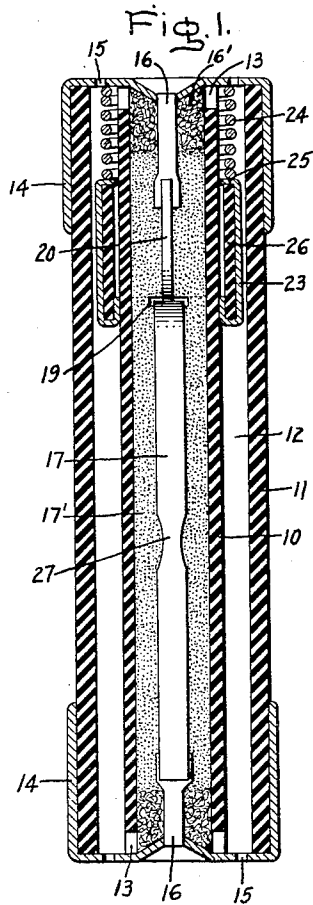

Inventor:
George R. Brown,
by *Harry E. Dunham*
His Attorney.

UNITED STATES PATENT OFFICE

2,180,975

TIME LAG FUSE

George R. Brown, Stratford, Conn., assignor to
General Electric Company, a corporation of
New York

Application December 8, 1938, Serial No. 244,632

6 Claims. (Cl. 200—113)

This invention relates to fuses for protecting electric circuits and particularly to time lag fuses for protecting electric circuits which are subjected to a partial overload for a predetermined period of time.

It is an object of the invention to provide an improved construction and arrangement in fuses of the type described which provides a quick and safe circuit interruption and which may be easily assembled and manufactured at low cost.

In the accompanying drawing Fig. 1 is a sectional view through the fuse; Fig. 2 is a partial view in section taken at right angles to the showing of Fig. 1; and Fig. 3 is a view similar to Fig. 2 showing the fuse structure just prior to blowing of the links.

Referring to the drawing, the invention is shown incorporated in a cartridge-type fuse but manifestly may be used with other types of fuses, such as a plug fuse. According to the invention a pair of concentric tubes of insulating material such as fiber, or the like, are provided one within the other and comprise an inner shell 10 and an outer casing 11, the inner shell being of substantially smaller diameter than the outer casing, thereby forming a space 12 between these elements. The inner shell 10 is provided at each end with slots 13 spaced around the perimeter thereof which form vents communicating the interior of the tubular shell 10 with the space 12 between the shell and the outer casing. The ends of the concentric tubes are closed by means of metallic ferrules 14 which serve as contact means for engagement with clips forming a holding means for the fuse. Both of the ferrules 14 are provided with openings 15 forming vents for a purpose to be described later.

Each of the ferrules 14 is provided with a centrally disposed contact rod 16 which may be formed of copper, or the like, one end of which is electrically connected to the respective ferrule and the other end of which extends inwardly within the confines of the inner shell 10. A fuse link 17 is placed within the shell 10 and connected at one end to one of the rods 16 and the other end is bent at an angle, as shown at 18, and is extended through an opening 19 formed in the wall of the shell so that it projects into the space 12 between the concentric tubes. A second fuse element 20 is likewise disposed within the tubular shell and is connected at one end to the other contact rod 16 with its other end being bent at an angle, as shown at 21, and extended similarly through the opening 19 within the space 12 where it is electrically connected to the fuse 17 as indi-

cated at 22 so that the fuse links are connected in series. The fuse links 17 and 20 are of dissimilar capacities and in the form of the invention shown the link 20 has an interruptive capacity less than that of the link 17. The shell 10 is filled with an inert material 17' such as chalk which surrounds the fuse links 17 and 20 and absorbs the gases incident to blowing of the fuse upon short circuit. The inert material is retained within the shell by means of plugs of fibrous material 16', such as asbestos, located at each end thereof which surround the contact rods 16 adjacent the vented openings 13 and prevent the inert material from sifting through the openings 13 into the space 12. In order to relieve the pressure within the shell 10 of the gases generated upon blowing of either or both of the fuse links, the asbestos plugs are made sufficiently porous so that the gases may pass therethrough and thence through the vents 13 to the outer space 12. In this manner the space 12 acts as an expansion chamber to relieve the gas pressures within the inner shell 10 and the gases may pass from the chamber 12 to the atmosphere through the vents 15 formed in both of the ferrules.

In order to render the fuse effective in protecting a circuit subject to a partial overload a time delay structure is provided for cooperation with the fuse links 17 and 20. This structure comprises a slider 23 which in the form shown is an annular ring of metal surrounding the inner shell 10 and which is adapted to slide in the space 12. The ring is electrically connected to the fuse links 17 and 20 at the point 22 by a low melting point solder, such as a 220° solder, and the slider is biased by means of a compression spring 24 bearing at one end against a flange 25 formed on the slider element and at the other end against the ferrule 14. The slider is provided with an internal insulating ring 26 which may be formed of fiber, or the like. It should be noted that the slider element 23 and the compression spring 24 form an electrical circuit parallel to the fuse link 20 and have a resistance depending upon the interruptive capacity of the link 20.

The resistance of this circuit comprising the slider and spring is made such that upon proper loading of the fuse the link 20, the slider 23 and the spring 24 form a path for the electric current sufficient to prevent blowing of the fuse 20 and the thermal capacity of the slider 23 is such that any heating of the fuse links 17 and 20 is dissipated by means of the slider element 23. However, should the fuse be subjected to a partial overload beyond a predetermined period of time

the thermal capacity of the slider element 23 is insufficient to dissipate the heat fast enough and the soldered joint 22 will melt permitting the spring 24 to drive the slider element downwardly, as shown by Fig. 3, thereby breaking the circuit through the slider 23 and the spring 24. This disconnects the parallel circuit through the slider and spring so that the full current passes through the link 20 causing it to blow. When the fuse blows in the manner indicated the insulating plate 26 is moved downwardly in front of the joint 22 and prevents any possibility of the circuit being reformed between the ends of the fuse links and the slider element 23. Moreover, the insulating ring serves to extinguish any arc which may have been formed between the ends of the links and the slider 23 upon breaking of the solder joint 22.

Whenever the fuse is subjected to a full overload, such as on short circuit, both of the fuse links 17 and 20 will blow, thereby providing an instantaneous interruption of the circuit. In order to control accurately the capacity of the fuse link 17 a blow point 27 is provided and this point is located intermediate the length of the link 17 where it is surrounded by the inert filler so that when it is fused upon a short circuit the gases incident to rupture of the fuse will be absorbed by the inert filler. On short circuit the soldered joint 22 will also melt permitting the spring to move the slider to a position where the insulating plate 26 covers the opening 19 in the shell 10 and prevents any of the hot gases or debris from the blown links passing through the opening 19 and damaging the outer casing 12.

By the construction described a fuse has been provided which serves to interrupt an electric circuit instantaneously upon short circuit and which at the same time provides a time lag protective means should the circuit be subjected to a partial overload for a predetermined time.

What I claim as new and desire to secure by Letters Patent of the United States is:

1. In a time lag fuse, a fuse link, a second fuse link electrically connected in series therewith, a heat storage mass fastened to the connection between said links by a fusible material and being electrically connected in parallel with one of said links, and means normally biasing said mass to break said fastening, said heat storage mass being capable of absorbing heat incident to a partial overload of said links for a predetermined period of time, but being insufficient to absorb said heat upon continued overload whereby said fusible material is melted and said biasing means forces said mass out of electrical connection with said links causing blowing of said one link.

2. In a time lag fuse, a fuse link, a second fuse link having a lower interrupting capacity than said first-mentioned link connected in series therewith to an electric circuit, a movable heat storage mass electrically connected to said links at said first-mentioned connection by a fusible material and being connected to said electrical circuit in parallel with said second link, and means biasing said mass to break the electrical connection with said links upon fusion of said fusible material due to an overload of said fuse links whereby said parallel circuit around said second link is broken to cause rupture of said second-mentioned fuse link.

3. A fuse comprising concentric inner and outer tubular casings of insulating material, ferrules closing the ends of said tubes, a pair of fuse links within said inner casing, one end of each link extending through an opening in said inner casing into the space between said casings and being electrically connected together, the other end of each of said links being connected to a respective ferrule, a slider element mounted in the space between said casings and being electrically connected to said links at said first-mentioned connection by fusible material, and a coil spring connected between said slider and one of said ferrules and biasing said slider away from said connection.

4. A fuse comprising concentric inner and outer casings of insulating material, ferrules closing the ends of said casings, a pair of fuse links of dissimilar capacity within said inner casing, one end of each link extending through an opening in said inner casing into the space between said casings and being electrically connected together, the other end of each of said links being connected to a respective ferrule, a slider element having a predetermined thermal capacity mounted in the space between said casings and being electrically connected to said links by a fusible material and a coil spring between said slider and one of said ferrules and biasing said slider away from said connection.

5. In a time lag fuse, a casing of insulating material, ferrules closing the ends of said casing, a fuse link mounted in said casing, a second fuse link having a lower interrupting capacity than said first-mentioned link mounted in said casing and electrically connected in series to said first-mentioned link, a movable heat storage mass electrically connected to said links at their point of interconnection by means of a fusible material, a spring positioned between one of said ferrules and said movable mass and normally biasing said mass to break the electrical connection with said links, said spring forming an electrical connection between said heat storage mass and ferrule parallel to the circuit through said second-mentioned link.

6. In a time lag fuse, concentric inner and outer casings of insulating material, said inner casing having an opening in the wall thereof, ferrules closing the ends of said casings, a pair of fuse links within said inner casing, one end of each link extending through said opening into the space between said casings and being electrically connected together, the other end of each of said links being connected to a respective ferrule whereby said links are placed in series in a circuit, a movable heat storage mass slidable in the space between said casings and being fastened to said links at said aforementioned electrical connection by fusible material, a spring disposed between said mass and one of said ferrules forming a circuit in parallel with one of said links and normally biasing said mass away from said connection, and an insulating plate carried by said mass, said fusible material melting under continued overload of said fuse whereby said spring moves said heat storage mass away from said connection to a position where said insulating plate covers the opening in said casing.

GEORGE R. BROWN. 70