

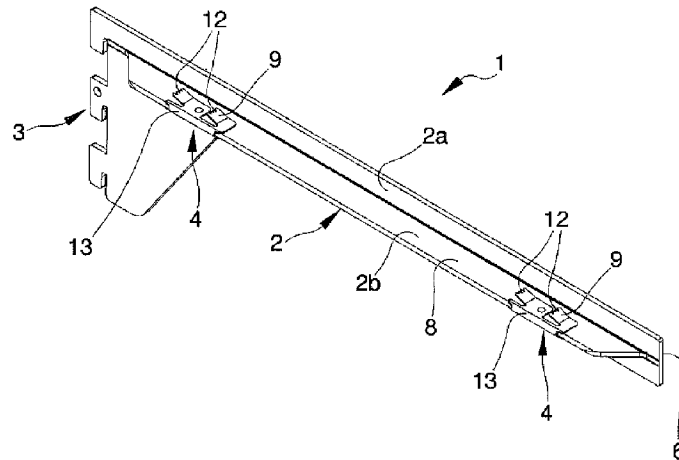

(86) Date de dépôt PCT/PCT Filing Date: 2014/05/08
(87) Date publication PCT/PCT Publication Date: 2014/11/13
(45) Date de délivrance/Issue Date: 2021/05/18
(85) Entrée phase nationale/National Entry: 2015/11/10
(86) N° demande PCT/PCT Application No.: IB 2014/061285
(87) N° publication PCT/PCT Publication No.: 2014/181276
(30) Priorité/Priority: 2013/05/10 (IT MO2013A000121)

(51) Cl.Int./Int.Cl. *A47B 96/06* (2006.01)
(72) Inventeur/Inventor:
BOSIO, LUCA, IT
(73) Propriétaire/Owner:
FAS S.R.L., IT
(74) Agent: MBM INTELLECTUAL PROPERTY LAW LLP

(54) Titre : DISPOSITIF DE SUPPORT D'ETAGERES ET ANALOGUES
(54) Title: DEVICE FOR THE SUPPORT OF SHELVES AND THE LIKE



(57) **Abrégé/Abstract:**

A device (1) for the support of shelves and the like, comprises at least a base element (2) having fastening means (3) to a supporting structure and removable locking means (4) with a shelf (5), where the base element (2) comprises a first portion (2a) intended to be placed, during use, externally to the shelf (5) and a second portion (2b) protruding from the first portion (2a) and which can be introduced inside a groove (7) obtained in the shelf itself, said, first and second portions (2a, 2b) having an elongated shape, and where the locking means (4) comprise at least an elastically yielding locator element (9), associated with the second portion (2b) and inclined with respect to the longitudinal extension thereof to define a fin, the locator element (9) being suitable for cooperating with the inner wall of said groove (7) to allow the relative movement of the shelf (5) with respect to the base element (2) along a direction of introduction (11) substantially parallel to the longitudinal extension of the second portion (2b) and to prevent the movement thereof in the opposite direction.

(12) INTERNATIONAL APPLICATION PUBLISHED UNDER THE PATENT COOPERATION TREATY (PCT)

(19) World Intellectual Property
Organization
International Bureau(10) International Publication Number
WO 2014/181276 A1(43) International Publication Date
13 November 2014 (13.11.2014)(51) International Patent Classification:
A47B 96/06 (2006.01)(21) International Application Number:
PCT/IB2014/061285(22) International Filing Date:
8 May 2014 (08.05.2014)

(25) Filing Language: Italian

(26) Publication Language: English

(30) Priority Data:
MO2013A000121 10 May 2013 (10.05.2013) IT

(71) Applicant: FAS S.R.L. [IT/IT]; Via Piedicavallo, 12, I-10145 Torino (IT).

(72) Inventor: BOSIO, Luca; c/o FAS S.r.l., Via Piedicavallo, 12, I-10145 Torino (IT).

(74) Agent: BRUNACCI, Marco; Brunacci & Partners S.r.l., Via Scaglia Est, 19-31, I-41126 Modena (IT).

(81) Designated States (unless otherwise indicated, for every kind of national protection available): AE, AG, AL, AM, AO, AT, AU, AZ, BA, BB, BG, BH, BN, BR, BW, BY, BZ, CA, CH, CL, CN, CO, CR, CU, CZ, DE, DK, DM,

DO, DZ, EC, EE, EG, ES, FI, GB, GD, GE, GH, GM, GT, HN, HR, HU, ID, IL, IN, IR, IS, JP, KE, KG, KN, KP, KR, KZ, LA, LC, LK, LR, LS, LT, LU, LY, MA, MD, ME, MG, MK, MN, MW, MX, MY, MZ, NA, NG, NI, NO, NZ, OM, PA, PE, PG, PH, PL, PT, QA, RO, RS, RU, RW, SA, SC, SD, SE, SG, SK, SL, SM, ST, SV, SY, TH, TJ, TM, TN, TR, TT, TZ, UA, UG, US, UZ, VC, VN, ZA, ZM, ZW.

(84) Designated States (unless otherwise indicated, for every kind of regional protection available): ARIPO (BW, GH, GM, KE, LR, LS, MW, MZ, NA, RW, SD, SL, SZ, TZ, UG, ZM, ZW), Eurasian (AM, AZ, BY, KG, KZ, RU, TJ, TM), European (AL, AT, BE, BG, CH, CY, CZ, DE, DK, EE, ES, FI, FR, GB, GR, HR, HU, IE, IS, IT, LT, LU, LV, MC, MK, MT, NL, NO, PL, PT, RO, RS, SE, SI, SK, SM, TR), OAPI (BF, BJ, CF, CG, CI, CM, GA, GN, GQ, GW, KM, ML, MR, NE, SN, TD, TG).

Published:

— with international search report (Art. 21(3))

— before the expiration of the time limit for amending the claims and to be republished in the event of receipt of amendments (Rule 48.2(h))

(54) Title: DEVICE FOR THE SUPPORT OF SHELVES AND THE LIKE

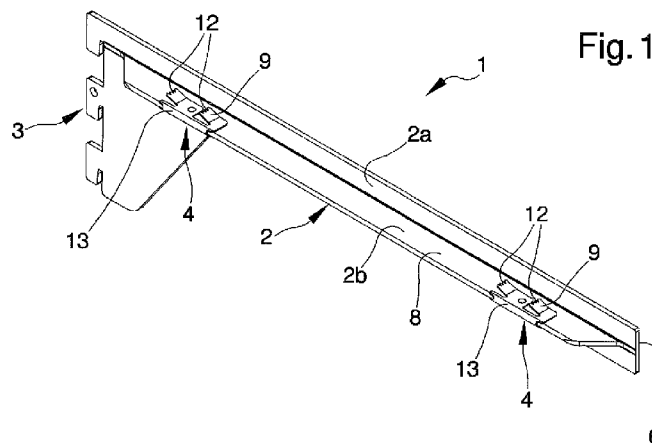

(57) **Abstract:** A device (1) for the support of shelves and the like, comprises at least a base element (2) having fastening means (3) to a supporting structure and removable locking means (4) with a shelf (5), where the base element (2) comprises a first portion (2a) intended to be placed, during use, externally to the shelf (5) and a second portion (2b) protruding from the first portion (2a) and which can be introduced inside a groove (7) obtained in the shelf itself, said, first and second portions (2a, 2b) having an elongated shape, and where the locking means (4) comprise at least an elastically yielding locator element (9), associated with the second portion (2b) and inclined with respect to the longitudinal extension thereof to define a fin, the locator element (9) being suitable for cooperating with the inner wall of said groove (7) to allow the relative movement of the shelf (5) with respect to the base element (2) along a direction of introduction (11) substantially parallel to the longitudinal extension of the second portion (2b) and to prevent the movement thereof in the opposite direction.



WO 2014/181276 A1

DEVICE FOR THE SUPPORT OF SHELVES AND THE LIKETechnical Field

The present invention relates to a device for the support of shelves and the like.

Background Art

5 Shelf units of known type generally comprise a shelf suitable for defining a supporting surface, which can be made of wood or other material, and at least a pair of support devices arranged on opposite sides of the shelf itself and which are made integral with a supporting wall.

The shelves are generally sheet-shaped (meaning by this definition that they
10 have two dimensions, length and width, considerably bigger than the third, thickness) and the support devices have means for removable locking to the relative shelf.

The known support devices are generally of two types.

In a first type, the support devices are shaped so as to cooperate with the
15 thickness of the relative shelf, in actual fact "embracing" the shelf itself laterally. More in particular, such support devices have a supporting element which is arranged, in use, in correspondence of the thickness of the relative shelf and which has a plurality of through holes for connecting to the shelf itself by means of threaded means.

20 In a second type, the support devices are shaped so as to sustain the relative shelf from below. More in particular, such support devices have at least a supporting element suitable for contacting the lower surface of the relative shelf. The locking means can consist of threaded elements or, alternatively, of one or more pins integral with the supporting element and suitable for inserting
25 themselves inside relative slots suitably obtained on the shelf itself. These devices of known type for supporting the shelves do however have a number of drawbacks.

They are in fact not easy to fit, inasmuch as they require either the use of threaded elements, both for fastening and for removing the shelf, or in any case
30 making the pins defined on the supporting element coincide with corresponding slots obtained in the shelf.

Furthermore, in particular in the case of the supporting element having the

above-mentioned pins, a plurality of jobs is needed to make the slots on the shelf. Such jobs must be highly precise to allow the correct and safe reciprocal coupling of the parts.

Another drawback of the known support devices consists in the fact that the locking means are always visible, thereby making the obtained shelf unit rather ugly to look at.

Description of the Invention

The main aim of the present invention is to overcome the drawbacks of the prior art.

10 In particular, the present invention intends providing a device for the support of shelves and the like which permits simplifying the ways of coupling with the relative shelf.

One object of the present invention is to provide a support device such as to also allow simplifying the jobs performed on the relative shelf.

15 Not the last object of the present invention is to make a support device whose locking means are not visible from the outside following coupling with the shelf itself.

Another object of the present invention is to provide a device for the support of shelves and the like which allows to overcome the mentioned drawbacks of the prior art in the ambit of a simple, rational, easy and effective to use as well as low cost solution.

The above mentioned objects are achieved by the present device for the support of shelves and the like according to claim 1.

Brief Description of the Drawings

25 Other characteristics and advantages of the present invention will become evident from the description of a preferred but not exclusive embodiment of a device for the support of shelves and the like, illustrated by way of an indicative, but not limitative, example in the accompanying drawings in which:

30 Figure 1 is an axonometric view of a device for the support of shelves and the like according to the invention;

Figure 2 is an enlargement of a detail of the device of Figure 1;

Figure 3 is a side elevation view of the device of Figure 1;

Figure 4 is an axonometric view of the device of Figure 1 in partial coupling with the relative shelf;

Figure 5 is an axonometric view of the shelf unit obtained following the coupling of the device of Figure 1 with the relative shelf.

5 Embodiments of the Invention

With particular reference to these figures, globally indicated by the reference number 1 is a device for the support of shelves and the like.

The device 1 comprises at least a base element 2 having fastening means 3 to a supporting structure (not shown in the illustrations) and removable locking
10 means 4 with a relative shelf 5. The shelf unit made up of the device 1 and of the shelf 5 coupled together is shown in figure 5 and identified by the reference number 10.

As the technician in the sector knows, the fastening means 3 can be of various types and can e.g. comprise one or more holes for inserting threaded elements
15 or, as in the embodiment shown in figure 1, elements for anchoring to a rack (not shown in the illustrations) fitted in the supporting structure.

The base element 2 has a free extremity, starting from which the shelf 5 is inserted and identified in the illustrations by the reference number 6, and the fastening means 3 are arranged in correspondence of the opposite extremity or,
20 alternatively, of a median area of the base element itself.

According to the invention, the base element 2 comprises a first portion 2a intended to be placed, during use, externally to the shelf 5 and a second portion 2b protruding from the first portion 2a and which can be introduced inside a groove 7 obtained in the shelf itself.

25 The first and the second portion 2a and 2b have an elongated shape and extend in the same longitudinal direction.

Preferably, the first portion 2a has a substantially parallelepiped or sheet shape (i.e., excepting fabrication and working tolerance defects) and the second portion 2b has a substantially sheet shape (i.e., excepting fabrication and
30 working tolerance defects) and extends starting on one side of the first portion itself. By sheet shaped, as used here, is meant a geometric shape characterized by two dimensions (width and length) prevalent with respect to the third

dimension (thickness). The second portion 2b therefore has two faces substantially parallel to one another and identified in the illustrations by the reference number 8.

In the embodiment shown in the illustrations, the second portion 2b is associated with the first portion 2a so as to define a T-shaped profile of the base element 2. More in particular, the second portion 2b extends starting from the median area of one side of the first portion 2a.

An alternative embodiment, not shown in the illustrations, can have two second portions 2b associated with two opposite faces of the same first portion 2a.

According to the invention, the locking means 4 comprise at least an elastically yielding locator element 9, associated with the second portion 2b and inclined with respect to the longitudinal extension of the second portion itself. More in particular, the locator element 9 is inclined so as to diverge outwards proceeding from the free extremity 6 towards the fastening means 3. The locator element 9 therefore defines a non-right angle with the longitudinal axis of the second portion 2b.

The locator element 9 is therefore shaped to define a fin protruding from the second portion 2b outwards. In other words, the locator element 9 is protruding from a relative face 8 of the second portion 2b.

The locator element 9 thus defined is suitable for cooperating with the inner wall of the groove 7 to allow the relative movement of the shelf 5 with respect to the base element 2 along a direction of introduction 11 substantially parallel to the longitudinal extension of the second portion 2b and to prevent its movement in the opposite direction. The direction of introduction 11 is therefore oriented from the free extremity 6 towards the fastening means 3.

More in particular, by effect of the sliding of the shelf 5 along the direction of introduction 11, the locator element 9 is pushed up closer to the second portion 2b, while it is pushed away from the second portion 2b following the movement of the shelf 5 in a direction opposite to the previous one.

Advantageously, the locator element 9 has adhesion means 12 defined in correspondence of its extremity intended to contact the inner wall of the groove 7.

In the preferred embodiment shown in the illustrations, the adhesion means 12 are of the tooth type. The adhesion means 12 shaped this way are therefore suitable for cooperating with the inner wall of the groove 7 so as to contrast the movement of the shelf 5 with respect to the base element 2 along the direction opposite to the direction of introduction 11. The action of the adhesion means 12 shaped this way is particularly effective in all those cases in which the shelf 5 is made of a wrinkly or porous type material such as, e.g., wood.

Suitably, the device 1 comprises at least two locator elements 9 arranged on the opposite side of the second portion 2b. More in particular, such locator elements 9 are arranged in correspondence of the two opposite faces 8 of the second portion 2b and are converging towards the second portion itself in the direction of its free extremity 6.

In a further embodiment, the device 1 comprises at least two locator elements 9 arranged on the same side as the second portion 2b and in succession with each other along the longitudinal extension of the second portion itself. In this embodiment, therefore, the locator elements 9 are arranged in correspondence of the same face 8 of the second portion 2b. Advantageously, such locator elements 9 have relative teeth 12 staggered the one to the other, in order to increase the effect of adhesion to the inner wall of the groove 7. In fact, because following the movement of the shelf 5 in an opposite direction to the direction of introduction 11 the tooth 12 of a locator element 9 tends to define a plurality of furrows on the wall of the groove 7 with which it comes into contact, by suitably staggering the teeth 12 of two consecutive locator elements 9, the tooth 12 of the subsequent locator element 9, with reference to the direction of introduction 11, is prevented from entering the furrow defined by the tooth of the locator element 9 which precedes it.

In the preferred embodiment shown in figure 1, the device 1 comprises four pairs of locator elements 9 arranged in succession the one to the other along the longitudinal extension of the second portion 2b, where the locator elements 9 of each of such pairs are arranged on opposite sides of the second portion itself.

For the technician in the sector, it is easy to appreciate how the number of locator elements 9 varies according to the length of the base element 2 and,

more in particular, to its second portion 2b.

Preferably, the locking means 4 comprise at least a locking element 13 associated integral with the second portion 2b and defining at least a pair of locator elements 9 arranged on opposite sides of the second portion itself. The locking element 13 is of the monolithic type and, therefore, the locator elements 9 defined by the same locking element 13 are integrally associated the one with the other.

More in detail, the locking element 13 is U-shaped and has two walls 13a substantially parallel to one another (excepting working tolerances), on each of which is defined at least a relative locator element 9. The locking element 13 made this way is fitted on the second portion 2b, in correspondence of its thickness, and the walls 13a are arranged, during use, in correspondence of the opposite faces 8 of the second portion 2b.

Preferably, the locking means 4 comprise, for each locking element 13, at least a pin 14 suitable for being fitted in a relative through seat defined on the second portion 2b and in relative holes 15 defined on each wall 13a of the locking element itself. Such pin 14 is therefore suitable for making the locking element 13 integral with the second portion 2b.

In the embodiment in figure 1, two locking elements 13 are provided associated with the second portion 2b, each of which supports two pairs of locator elements 9 arranged in succession along the longitudinal extension of the second portion itself.

The operation of the device according to the invention is the following.

In order to make a shelf unit 10 of the type of that shown in figure 5, two devices 1 must first of all be fastened to a supporting structure by means of the relative fastening means 3, after which the shelf 5 is fitted on these.

More in particular, the shelf 5 has a pair of grooves 7 defined in correspondence of two of its opposite sides, each of which is made to slide on the second portion 2b of a relative device 1 starting from its free extremity 6.

Subsequently, the shelf 5 thus positioned along the direction of introduction 11 is made to move forward.

Following such forward movement, the locator elements 9 arranged along the

longitudinal extension of the relative second portion 2b move towards the second portion itself by effect of the contact with the inner wall of the corresponding groove 7, in such a way as not to hinder the relative movement of the shelf 5 with respect to the base element 2. During the forward movement of the shelf 5 along the direction of introduction 11, the locator elements 9 arranged on opposite sides of the relative second portion 2b therefore bend in a direction of reciprocal approach.

Once the shelf 5 has been brought to the final position of use, this is blocked with respect to the relative support devices 1.

10 More in particular, the shelf 5 cannot be removed from the devices 1 by applying a force in the opposite direction to the direction of introduction 11 because, following such movement, the locator elements 9 are pushed by the wall of the groove 7 with which they come into contact in a reciprocal moving away direction, thus contrasting the movement of the shelf 5. Furthermore, 15 following such movement of the shelf 5, the adhesion means 12 cooperate with the inner wall of the corresponding groove 7 by applying a further action of contrast to the movement of the shelf itself.

The support devices 1 can in any case be removed from the shelf 5 by applying, on the one or on the other, a traction force directed orthogonally to the direction 20 of introduction 11.

It has in fact been ascertained how the described invention achieves the proposed objects and in particular the fact is underlined that the support device forming the subject of the present invention allows fitting a relative shelf in an extremely practical, easy and safe way.

25 More in particular, the elastically yielding locator elements with which the device is equipped according to the invention, permit fastening a relative shelf without the aid of further threaded means.

Again, the locking means forming the subject of the present invention are completely integrated in the shelf, following the fitting of same on the relative support device, and are not therefore visible from outside. It is easy to 30 appreciate how this gives the shelf unit thus obtained a particularly attractive aesthetic appearance.

THE EMBODIMENTS OF THE INVENTION FOR WHICH AN EXCLUSIVE PROPERTY OR PRIVILEGE IS CLAIMED ARE DEFINED AS FOLLOWS:

- 1) Device (1) for the support of shelves and the like, comprising a base
5 element (2) having fastening means (3) to a supporting structure and removable locking means (4) with a shelf (5), where said base element (2) comprises a first portion (2a) intended to be placed, during use, externally to the shelf (5) and a second portion (2b) protruding from said first portion (2a) and which can be introduced inside a groove (7) obtained in the shelf itself, said first and second
10 portions (2a, 2b) having an elongated shape, said base element (2) having a free longitudinal extremity (6), and characterized in that said locking means (4) comprise at least an elastically yielding locator element (9), associated with said second portion (2b) and inclined with respect to the longitudinal extension thereof to define a fin, said locator element (9) being diverging outwards
15 proceeding from said free extremity (6) towards said fastening means (3) and being suitable for cooperating with the inner wall of said groove (7) to allow the relative movement of the shelf (5) with respect to the base element (2) along a direction of introduction (11) substantially parallel to the longitudinal extension of said second portion (2b) and to prevent the movement thereof in the opposite
20 direction.
- 2) Device (1) according to claim 1, characterized in that said locator element (9) has adhesion means (12) defined in correspondence of its extremity intended to contact the inner wall of said groove (7).
25
- 3) Device (1) according to claim 2, characterized in that said adhesion means (12) are of the type of a tooth.
- 4) Device (1) according to any one of claims 1 to 3, characterized in that it
30 comprises at least two of said locator elements (9) arranged opposite said second portion (2b).

5) Device (1) according to any one of claims 1 to 4, characterized in that it comprises at least two of said locator elements (9) arranged on the same side as said second portion (2b) and in succession with each other along the longitudinal extension of the second portion itself.

5

6) Device (1) according to claim 5, characterized in that said locator elements (9) arranged in succession with each other have relative teeth (12) staggered the one to the other.

10 7) Device (1) according to any one of claims 1 to 6, characterized in that said locking means (4) comprise at least a locking element (13) defining at least a pair of said locator elements (9) arranged on opposite sides of said second portion (2b).

15 8) Device (1) according to claim 7, characterized in that said locking element (13) defines at least two pairs of said locator elements (9) arranged in succession along said second portion (2b), the locator elements (9) of each of said pairs being arranged on opposite sides of the second portion itself.

20 9) Device (1) according to claim 8, characterized in that said locking element (13) is U-shaped and is fitted on said second portion (2b), said locator elements (9) being defined on the two opposite walls (13a) of the locking element itself.

10) Device (1) according to claim 9, characterized in that said locking means (4)
25 comprise at least a pin (14) which fits in a relative through seat defined on said second portion (2b) and in a relative hole defined on each of the walls (13a) of said locking element (13), said pin (14) making said locking element (13) integral with said second portion (2b).

30 11) Shelf unit (10), characterized in that it comprises:

- at least a substantially sheet-shaped shelf (5) having a groove (7) defined along its thickness;

- at least a device (1) for supporting said shelf (5) comprising a base element (2) having fastening means (3) to a supporting structure and having a first portion (2a) arranged during use externally to said shelf (5) and a second portion (2b), which fits during use inside said groove (7), having an elongated shape, said base element (2) having a free longitudinal extremity (6), and where said supporting device (1) comprises at least an elastically yielding locator element (9), associated with said second portion (2b) and inclined with respect to its longitudinal extension to define a fin, said locator element (9) being diverging outwards proceeding from said free extremity (6) towards said fastening means (3) and being suitable for cooperating with the inner wall of said groove (7) to allow the relative movement of the shelf (5) with respect to the base element (2) along a direction of introduction substantially parallel to the longitudinal extension of said second portion (2b) and to prevent the movement thereof in the opposite direction.

1/3

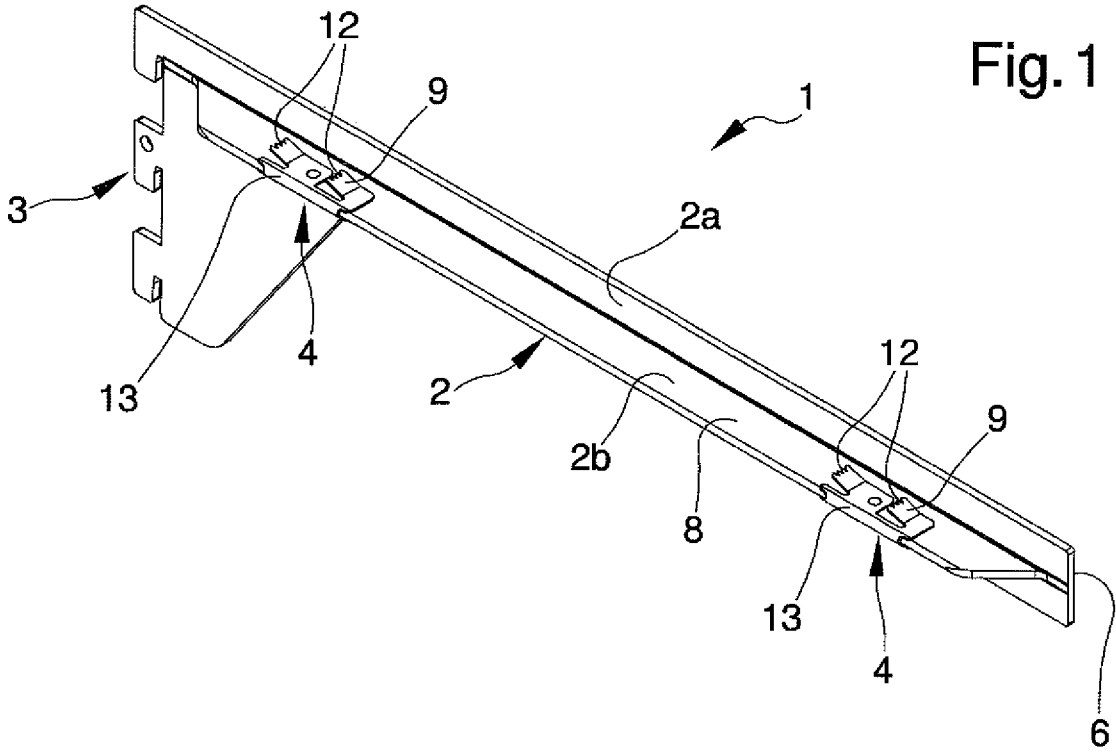

Fig. 1

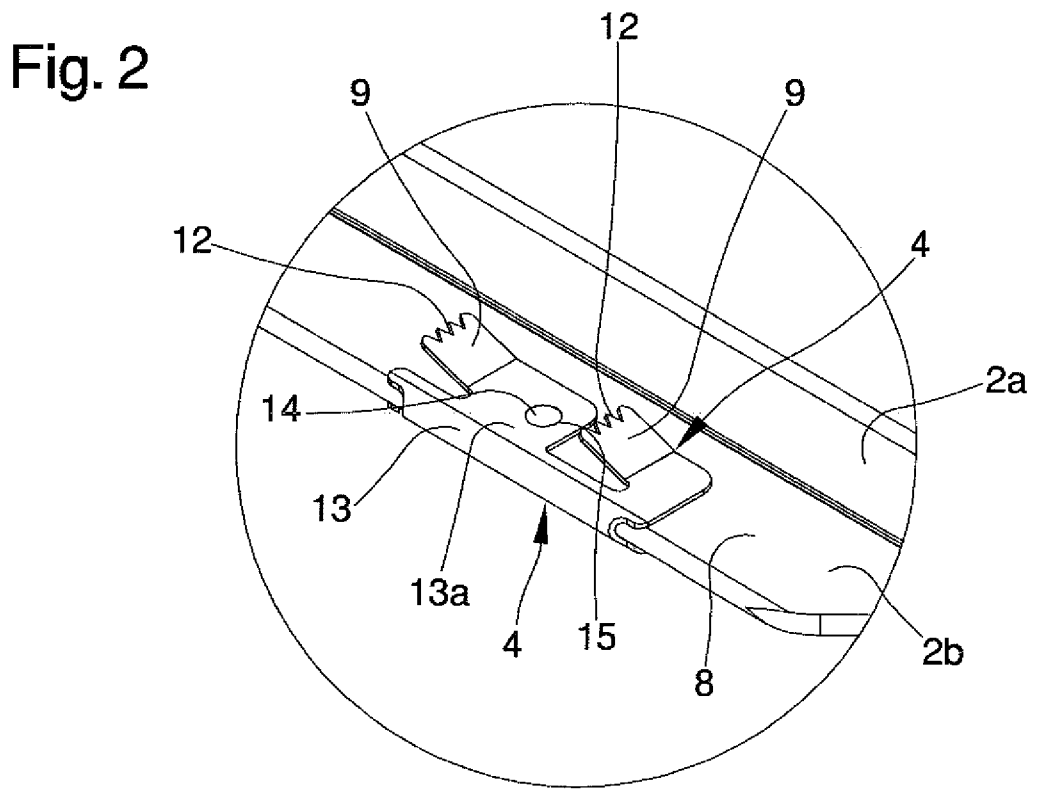

Fig. 2

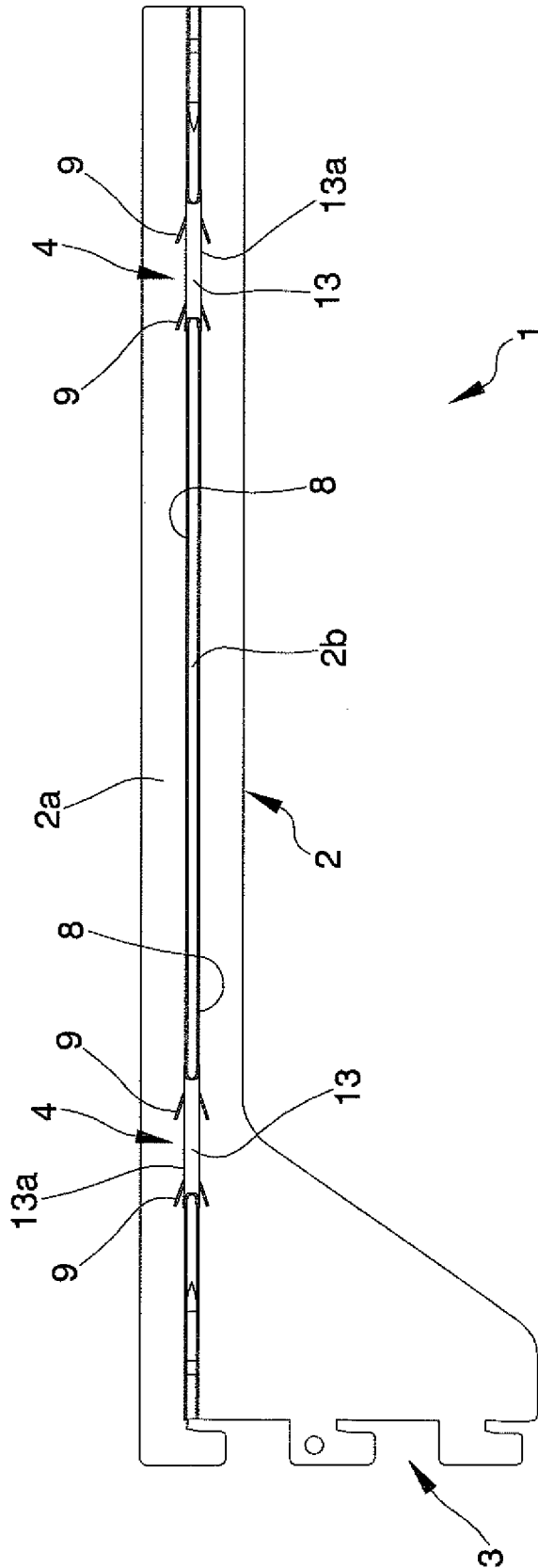

Fig. 3

