

(No Model.)

3 Sheets—Sheet 1.

F. W. MERRICK.
SEWING MACHINE.

No. 343,383.

Patented June 8, 1886.

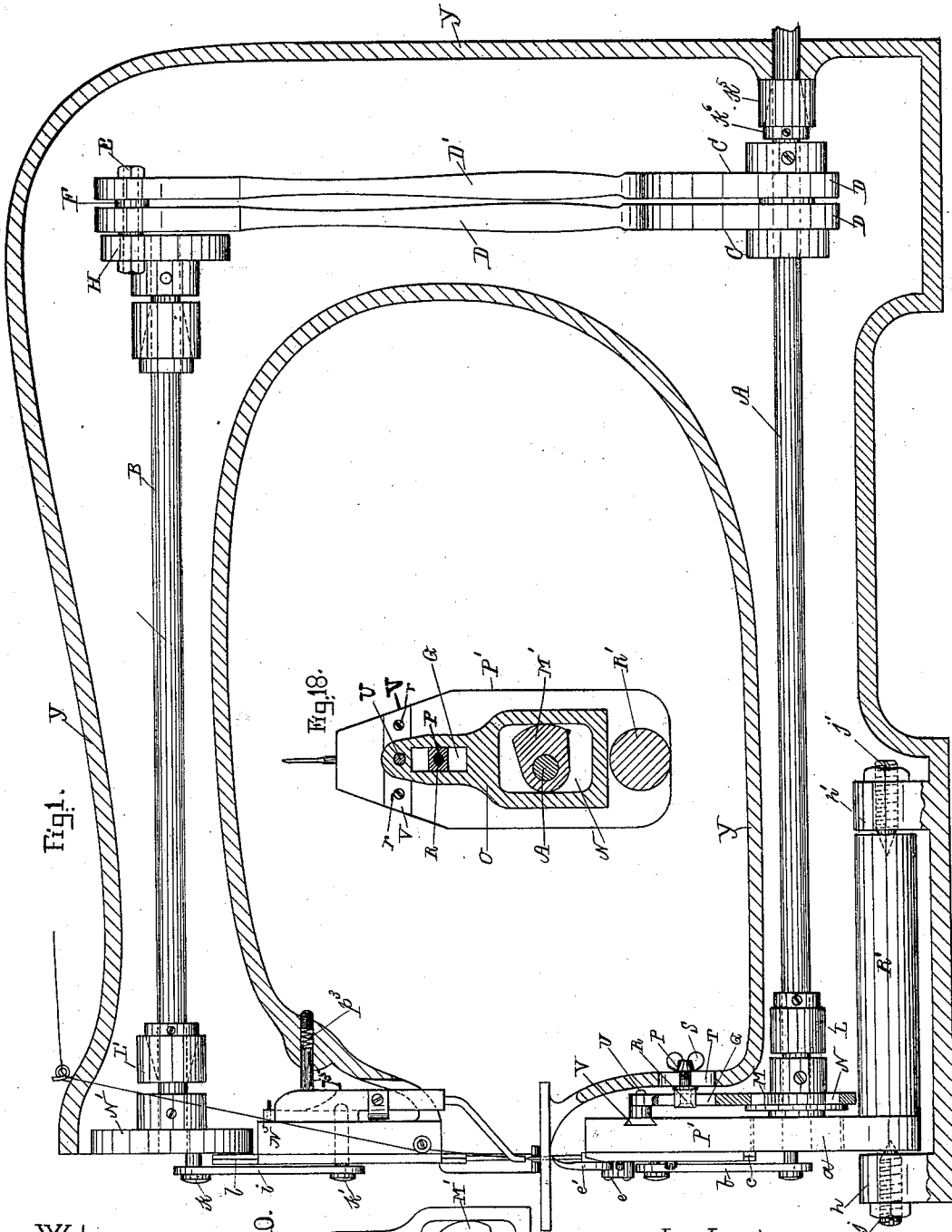

Fig. 1.

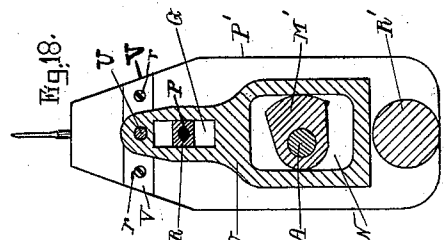

Fig. 18.

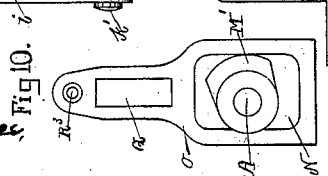

Fig. 10.

Witnesses

Robert Wallace,
Laird M. Keller.

Inventor

Frank W. Merrick
by Wm. A. MacLeod
his atty

F. W. MERRICK.
SEWING MACHINE.

No. 343,383.

Patented June 8, 1886.

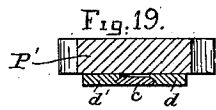
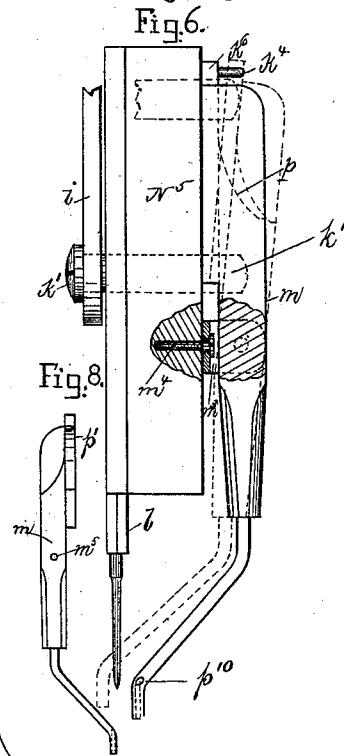
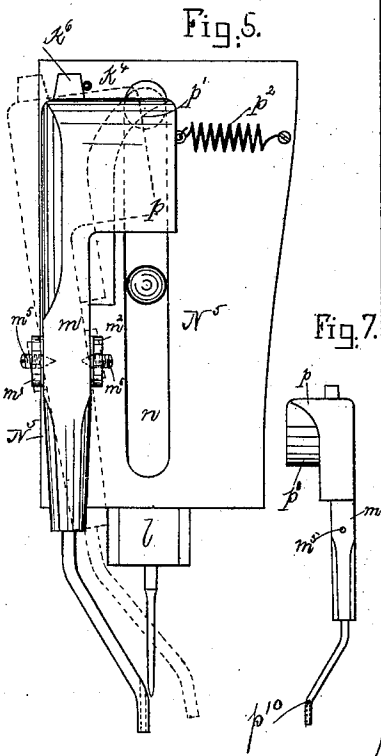
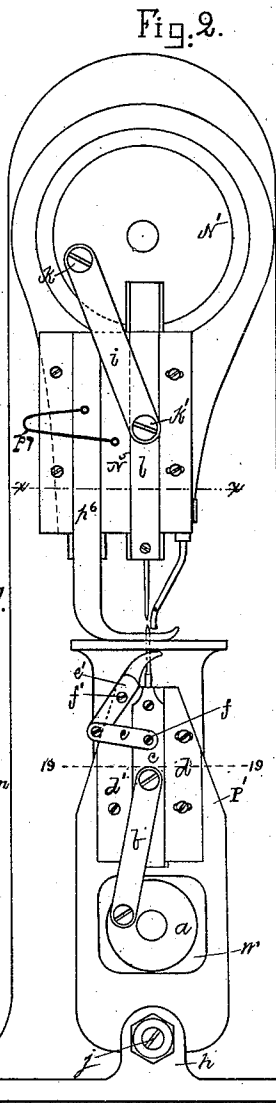
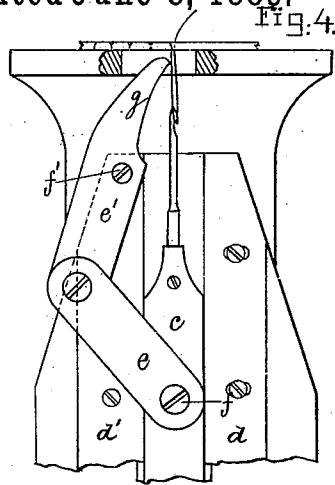
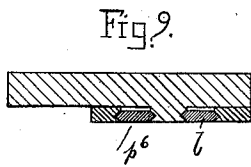
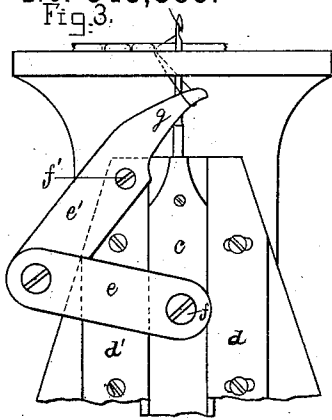

Witnesses.

Robert Wallace,
Lauritz W. Moller,

Inventor.

Frank W. Merrick
by W. A. Macleod
his atty

(No Model.)

3 Sheets—Sheet 3.

F. W. MERRICK.
SEWING MACHINE.

No. 343,383.

Patented June 8, 1886.

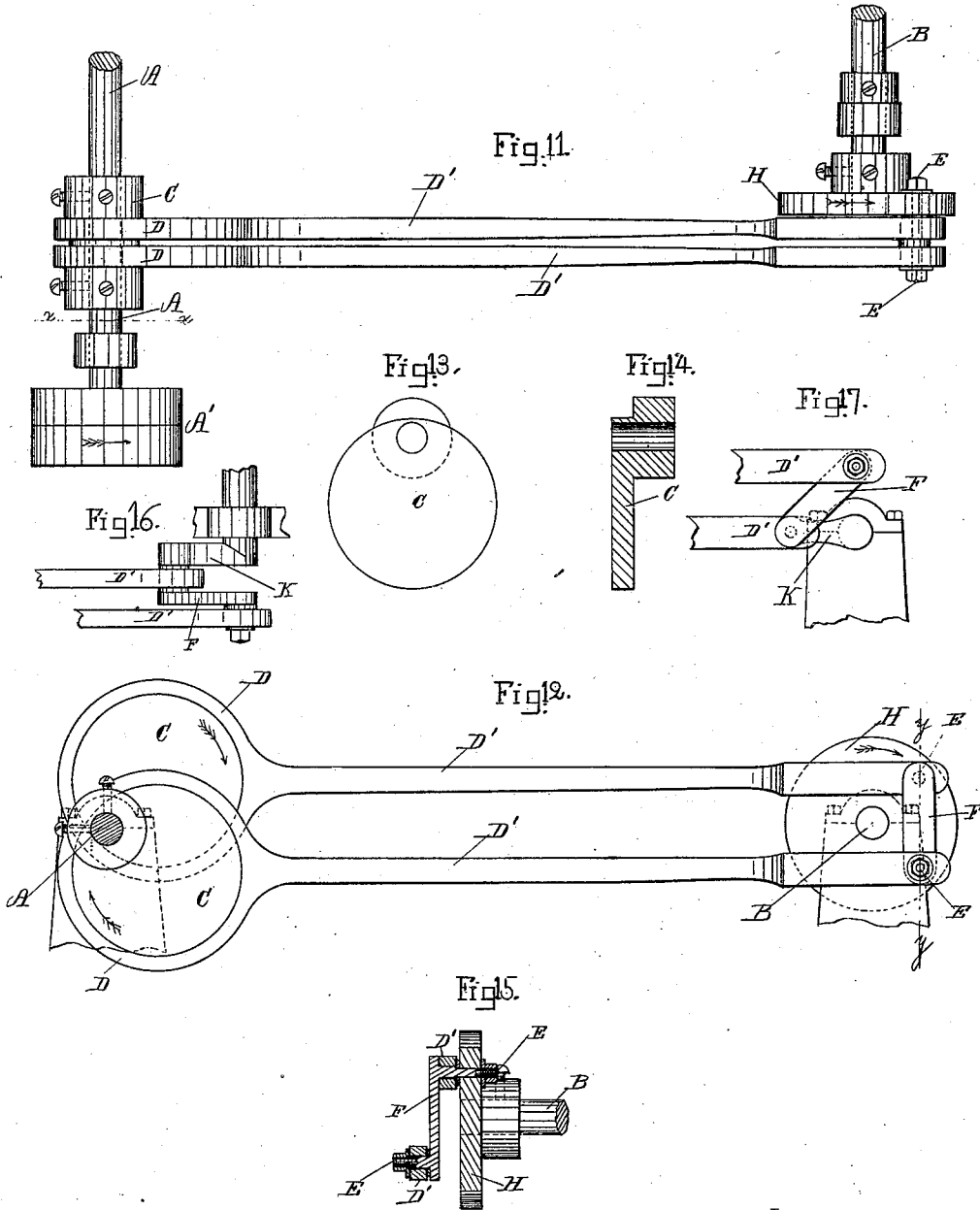

Witnesses.

Carl H. Müller
Lauritz W. Möller.

Inventor.

Frank W. Merrick
by Wm. A. Macleod
his Atty

UNITED STATES PATENT OFFICE.

FRANK W. MERRICK, OF SOMERVILLE, MASSACHUSETTS.

SEWING-MACHINE.

SPECIFICATION forming part of Letters Patent No. 343,383, dated June 8, 1886.

Application filed December 15, 1885. Serial No. 185,688. (No model.)

To all whom it may concern:

Be it known that I, FRANK W. MERRICK, of Somerville, county of Middlesex, State of Massachusetts, have invented certain new and useful Improvements in Sewing-Machines, of which the following is a full, clear, concise, and exact description, reference being had to the drawings accompanying and forming a part hereof, in which—

Figure 1 is a sectional side elevation of the machine. Fig. 2 is a front elevation. Figs. 3 and 4 are details showing the position of the cast-off when the needle is up and down, respectively. Figs. 5 and 6 are respectively side and end views of the thread-carrier and adjacent parts. Figs. 7 and 8 are details of the thread-carrier detached. Fig. 9 is a section on line *x x*, Fig. 2. Fig. 10 is a detail of the yoke and cam which reciprocate the needle-post. Fig. 11 is a detail view of the mechanism for conveying the motion and power of the driving-shaft to the secondary shaft. Fig. 12 is a side elevation of the parts shown in Fig. 11. Figs. 13 and 14 are respectively a plan and section of the eccentrics on the driving-shaft. Fig. 15 is a section on line *y y*, Fig. 12. Figs. 16 and 17 are a plan and elevation, respectively, of a modified form of the double crank on the secondary shaft. Fig. 18 is a rear view of the needle-post and its operating yoke and cam. Fig. 19 is a cross-section on line 19 19, Fig. 2.

The object of my invention is to provide a sewing-machine which shall be simple, economical, and easy of construction; and it consists in the mechanism hereinafter more fully described, as indicated by the claims at the end of this specification.

Like letters of reference indicate like parts throughout the drawings.

I will describe my invention as embodied in the machine shown in the accompanying drawings.

Y is the frame of the machine. A is the driving-shaft, which actuates directly the needle, feed, and cast-off mechanism, and B is a secondary shaft, which actuates the awl and thread-carrier mechanism.

The power of the driving-shaft is conveyed to the secondary shaft by the following described mechanism: On the driving-shaft I secure two eccentrics, C C, which are shown,

Fig. 12, as set quartering with each other. They may be set in any position relatively to each other so long as they are not together or diametrically opposite. In these latter positions their dead-points would fall together, and the mechanism would be inoperative. The eccentrics C C are provided with straps D D, (see Fig. 12,) within which the eccentrics rotate, and which are secured to or formed integral with pitmen D' D', which are pivoted at their ends on the crank-pins E E of the double or two-throw crank F. One of these crank-pins is set fast in a disk-wheel, H, (see Fig. 15,) which is secured to shaft B. The two-throw crank F may obviously be fast to or integral with an arm, K, (see Figs. 16 and 17,) which arm may be secured to or may be integral with the secondary shaft. I prefer, however, to use the disk-crank H, instead of an arm, K, although, as will be obvious, either form will work. If the eccentrics on the driving-shaft are set quartering—that is, ninety degrees apart—of course the crank-pins E E will also require to be ninety degrees apart. The eccentrics and crank-pins will necessarily be placed in the same position relatively, although, as previously stated, not necessarily ninety degrees apart. The quartering positions shown, however, I believe to be the most efficient. As will be obvious, the eccentrics on the main shaft may be replaced by cranks; but I prefer to use eccentrics. By the use of this method of conveying the power of the main shaft which actuates the parts of the machine below the table to the secondary shaft which actuates the parts above the table, the various movements may be timed perfectly, and as there is no lost motion there is little liability of the movements of the parts getting out of the proper time.

The forward end of the main shaft is journaled in a bracket, L, inside the frame Y, and is provided in front of this bearing with a collar, M, having a cam, M', secured thereto, the collar and cam being fast to the shaft. This collar and cam act in an oblong slot or opening, N, in the yoke O, the curve of the cam being eccentric to the shaft A. As the shaft rotates, the throw of the cam is communicated to the yoke, which is pivoted above, at P, to the frame of the machine. In order that this pivotal point may be adjustable, an oblong

slot, Q, is cut in the yoke O, and a block, R, on the end of pivot P, is placed therein and adapted to beslid upward and downward in the slot. Behind the block is a collar or shoulder 5 on the pivot P, and the other end of the pivot is provided with a thumb-nut, S, by means of which the pivot may be secured in the slot T in the frame. The upper end of the yoke O is journaled on a stud, U, which is set in a 10 dovetailed slide, V, (see Figs 1 and 18,) fitted into the inner face of the needle-post. The slide V is provided with set-screws, *v*, by which it may be held in given position. By loosening the set-screws the slide may be 15 moved for the purpose of putting the needle and awl in line, if that should become necessary. The rotation of the main shaft communicates the throw of cam M' to the yoke O, thus vibrating it on pivot P and causing its 20 upper end to vibrate or reciprocate reversely, and thus reciprocate the needle-post P' on its rocker-bearing R', thus causing the work to be fed forward.

In an opening, W, in the needle-post, (see 25 Fig. 2,) a crank-disk, *a*, is set, which is fast on the main shaft. A link, *b*, is pivoted at one end to the disk and at the other to the needle-bar *c*, which slides upward and downward between the plates *d d'*, secured to the 30 face of the needle-post, the edges of the plates *d d'* having V-shaped grooves which receive the correspondingly-shaped edges of the needle-bar. In this way the needle-bar slides only on its edges, its rear face being out of 35 contact with the post, thus reducing the friction of its movements. The plate *d* is adjustably secured to the needle-post, so that as the needle-bar wears, the plate may be set in and the wear taken up. By the use of strap or 40 link *b* the rotary movement of the main shaft is converted into the reciprocating movement of the needle-bar, as will be obvious. (See Fig. 2.) The opening W in the needle-post, to accommodate the disk *a*, is enough larger 45 than the disk to allow for the vibratory feed-movement of the post. The cast-off mechanism consists, chiefly, of a link, *e*, pivotally attached to the needle-bar by a screw, *f*, and connected to a lever, *e'*, pivoted to the post 50 at *f'*. (See Figs. 3 and 4.) The upper end of the lever *e'* is tapered to form the beak *g*, (see Figs. 3 and 4,) so that as the needle which moved downward with the loop of thread in its hook begins to rise the cast off point *g* of 55 the lever enters the loop and frees it from the hook, the needle passes upward beside the point or beak *g*, and draws down the next loop through the previous one, which slips off the beak *g*, when the beak is thrown up and back 60 by the downward movement of the needle-bar to the position shown, Fig. 4.

The method of mounting the needle post to allow of its free vibration with the least friction, and to insure against any change of the 65 plane of vibration, is as follows: The post is provided with a boss or shaft, R', which is fast to its lower end and projects rearwardly

therefrom. This shaft is mounted between projections *h h'* on the base of the frame by means of the screws *j j'*, which are screwed 70 into the projections, and which have tapering ends, as shown, Fig. 1, which are received in correspondingly-shaped recesses, one at the rear end of the shaft R' and the other in line with it in the front of the post. The length 75 of the shaft R' prevents the shaking or jarring of the post out of position, while it is so hung as to be easily vibrated.

Passing to the upper part of the machine, the secondary shaft B is journaled at its front 80 end in a projection, L', of the frame, and is provided at its front end with a crank-disk, N', fast thereto. To this disk is pivoted at *k* a connecting strap or link, *i*, the other end of which is pivoted to the awl-bar *l* at *k'*. The 85 awl-bar is mounted between adjustable plates secured to the face of the frame of the machine in the same manner as the needle-bar below, and, as is shown in cross-section, Fig. 9, so that the rotation of the disk N on the second- 90 ary shaft causes the reciprocation of the awl-bar. (See Fig. 2.)

On the rear of one edge of the face N⁵, which carries the awl-bar, the thread-carrier bar *m* is pivoted between the lugs *m' m''*. (See Fig. 95 5.) This allows the thread-carrier bar to be swung backward and forward, and as the lugs *m' m''* are joined by a base-plate, *m³*, (see Fig. 6,) which is pivoted to the frame by pivot *m⁴*, the thread-carrier bar is allowed to swing side- 100 wise. By means of these two motions the thread-guide is made to follow a right-angled path around the point of the needle, and thus place the thread in the hook.

In order to actuate the thread-guide, the 105 pivot *k'*, which secures the lower end of strap *i* to the awl-bar, is allowed to project rearwardly through a slot, *n*, (see Fig. 5,) in the face N⁵, and comes in contact, as the awl-bar is at the upper part of its throw, with two cam- 110 faces cut in the upper part of the thread-carrier bar *m*. It first encounters in its upward movement the cam-face *p*, (shown by the dotted line in Fig. 6,) and throws the upper end of the thread-carrier bar rearwardly, swinging the 115 bar on its pivot *m³*, and moving the thread-carrier forward. After this movement is completed the pin *k'* takes the second cam-face, *p'*, (see dotted line Fig. 5,) and forces the upper end of the thread-carrier bar to the right, viewed 120 from the front of the machine, swinging it on the pivot *m⁴*, and causing the thread-carrier to move to the left past the point of the needle. As the awl-bar moves downward again the 125 spiral spring *p²*, fast at one end to the frame and at the other to the upper end of the carrier, insures the movement of the carrier in a reverse direction until projection *k⁶* strikes the stop-pin *k¹*, when the bar is in position for the next movement. In like manner the spiral 130 spring *p²*, (see Fig. 1,) moves the thread-carrier bar back against face N⁵ of the frame in a reverse direction from the movement given it by cam *p*. The spiral spring *p²* is set in a

socket in the frame, (see Fig. 1,) and bears against a pin, p^5 , which lies in the socket, and projects therefrom against the thread-carrier. (See Fig. 1.)

5 The thread-carrier eye p^{10} is placed in a nearly vertical position. (See Figs. 6 and 7.)

The shafts A and B are shown mounted with conical bearings, as at h^5 h^6 , Fig. 1, in a well-known manner.

10 The presser-foot bar p^6 (see Figs. 2 and 9) is mounted in the face of the frame in the same way as is the awl-bar l , and may be operated in any well-known manner. I have shown a simple spring, p^7 , (see Fig. 2,) fast at one end
15 thereto and at the other to the frame. This spring serves to hold the presser-foot down upon the work. A lever and cam of common construction (not shown) may be employed to raise it and hold it up.

20 What I claim is—

1. In a sewing-machine, the combination, with the awl and needle bars, of two rotating shafts, one above and the other below the work-plate, two differently-placed eccentrics
25 on one of said shafts, a two throw crank on the other of said shafts, two links connecting said eccentrics and crank, crank-disks on the forward ends of said shafts, and links connecting the said crank-disks with the said awl and
30 needle bars, substantially as set forth.

2. The combination, with the pivoted nee-

dle-post P' , of the yoke O, pivotally connected at its upper end to said post, the shaft A, provided with a cam working within said yoke, and an adjustable fulcrum for said yoke between its connection with said needle-post and
35 said cam, substantially as set forth.

3. The combination, with the machine-frame having the projections h and h' , of the needle-post P' , having the rearwardly-extending shaft
40 R' , pivoted to said projections, whereby a steady pivotal bearing is afforded for said post on said frame, substantially as set forth.

4. The combination, with the reciprocating needle-bar, of the lever e' , pivoted to the needle-post and provided with the cast-off g , and
45 the link e , connecting said lever and needle-bar, substantially as set forth.

5. The combination, with the needle-bar, its hooked needle, and the head or face N^5 , of
50 the thread-carrier bar connected with said head or face by two pivots at right angles to each other, and having two cams at its upper end, a reciprocating pin extending through said head or face and adapted to engage said
55 cams, and springs for effecting the return movements of said thread carrier bar, substantially as set forth.

FRANK W. MERRICK.

In presence of—

WM. A. MACLEOD,
ROBERT WALLACE.